

Series **D XX S 24A 6 XX 22 LF**

Number of contacts
09 , 15 , 25

Contacts
S : Socket

Plating
6 - 500 Mating / Unmating Mini

Packaging specification
Tape and Reel For connector with cap

See Note RoHS

Termination

Code	Type	Foot Print/Pitch	Length of termination	PCB thickness
24A	Straight version	6 / 2.84mm	2	1.6

NOTE RoHS INFORMATION

- The "LF" product meet european union Directives and other country regulations asdescribed in GS-22-008.
- The housing will withstand exposure to 260^o peak temperature for 30 seconds in a convection , infra-red or vapor reflow oven. See application notes/procedures if are available.
- Termination plating spec:1.27 μ Nickel mini,2.5 to 7.5 μ Sn(pure mate)
- Shell plating : Nickel bright
- Accessories : Sn pure bright
- Packaging spec ; See GS-14-920

Mounting Options

RL	Insert M3
RV	Female Screw UNC 4-40
RX	Insert UNC 4-40

Product Specification

see : GS-12-372

Packaging Specification

See GS-14-1052

www.fciconnect.com		surface <input checked="" type="checkbox"/> ISO 1302	tolerance std ISO 406 ISO 1101	projection	mm
TOLERANCES UNLESS OTHERWISE SPECIFIED					
Dr	P. CRON	02/02/06	ANGULAR	0.X ±0.3	size A3
Eng	H. LEGALLIC	02/02/06	LINEAR	0.XX ±0.1	Scale 2:1
Chr	NIRMAL G	2010-10-14	0° ±2°	0.XXX ±0.05	ECN 110-0197
Appr	SUDHIR V	2010-10-14	Product family		Spec ref
FCi		SUB DELTA D PIP FEMALE H=2		dwg no C01-8646-0875	Rev. G
straight for tape and reel packaging		SEE TABLE		CUSTOMER	sheet 1 of 2
catalog no					

rev	ecn no	dr	date
A	-	HLE	02/02/06
B	LS06-0040	PC	23/03/06
C	LS06-0105	HLE	25/07/06
D	LS06-0220	PCR	2006/12/21
E	LS07-0050	HLE	2007/03/02
F	110-0120	NG	2010-05-27
G	110-0197	NG	2010-10-14

With CAP

Without CAP

PCB Card Drilling dimensions and Pads recommended (after plating - Thickness : 1.60 mm)

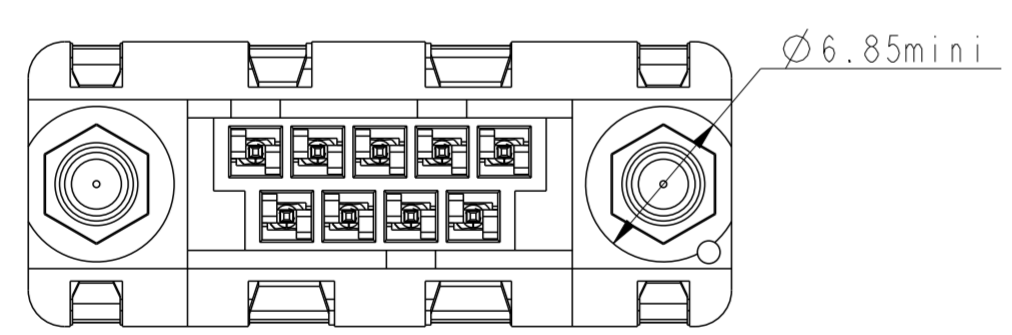
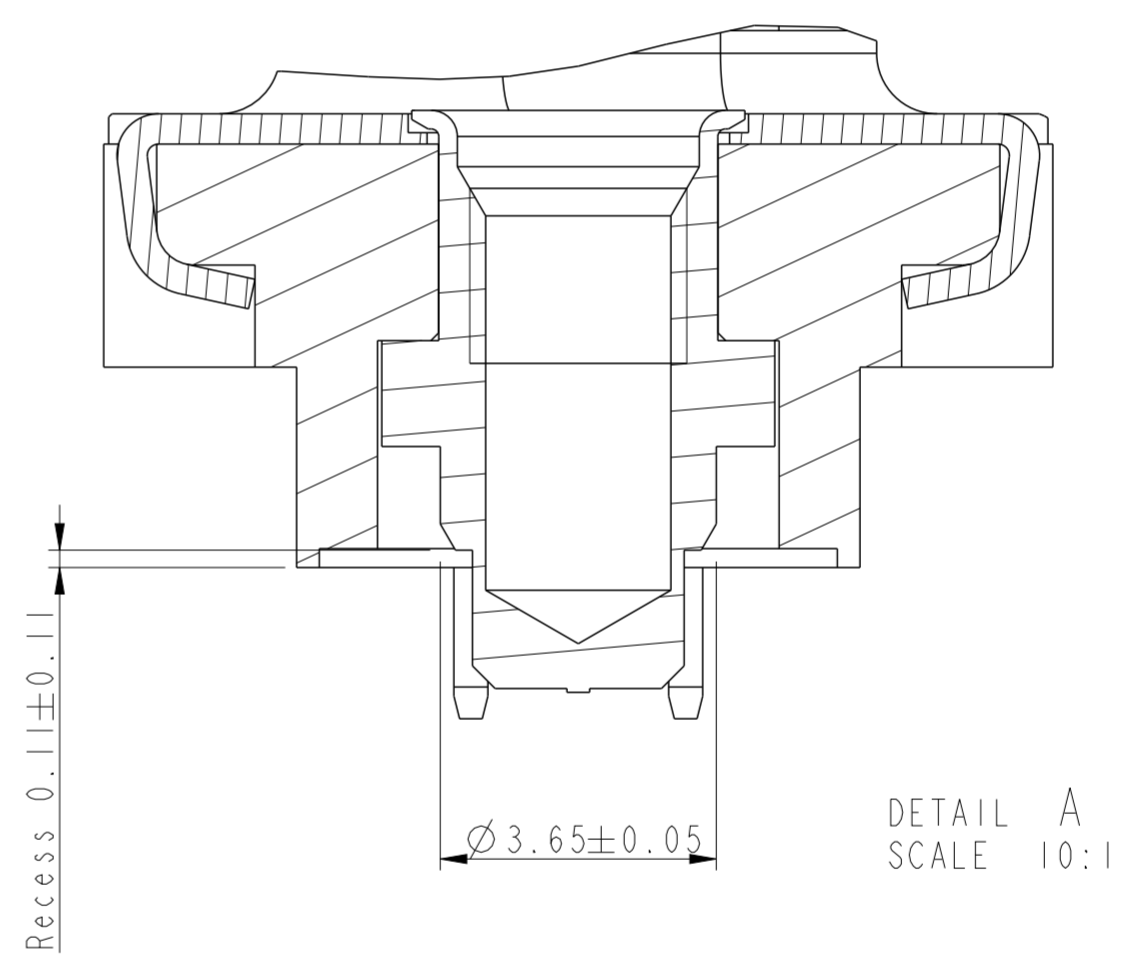
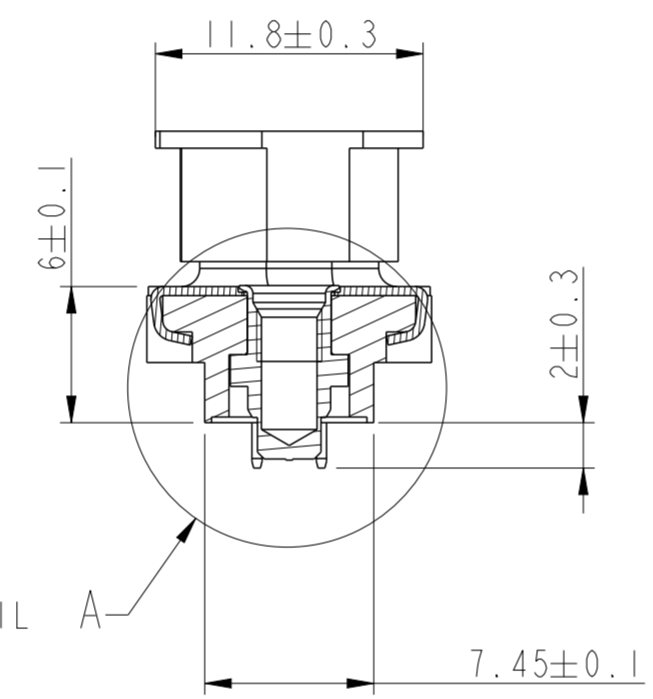
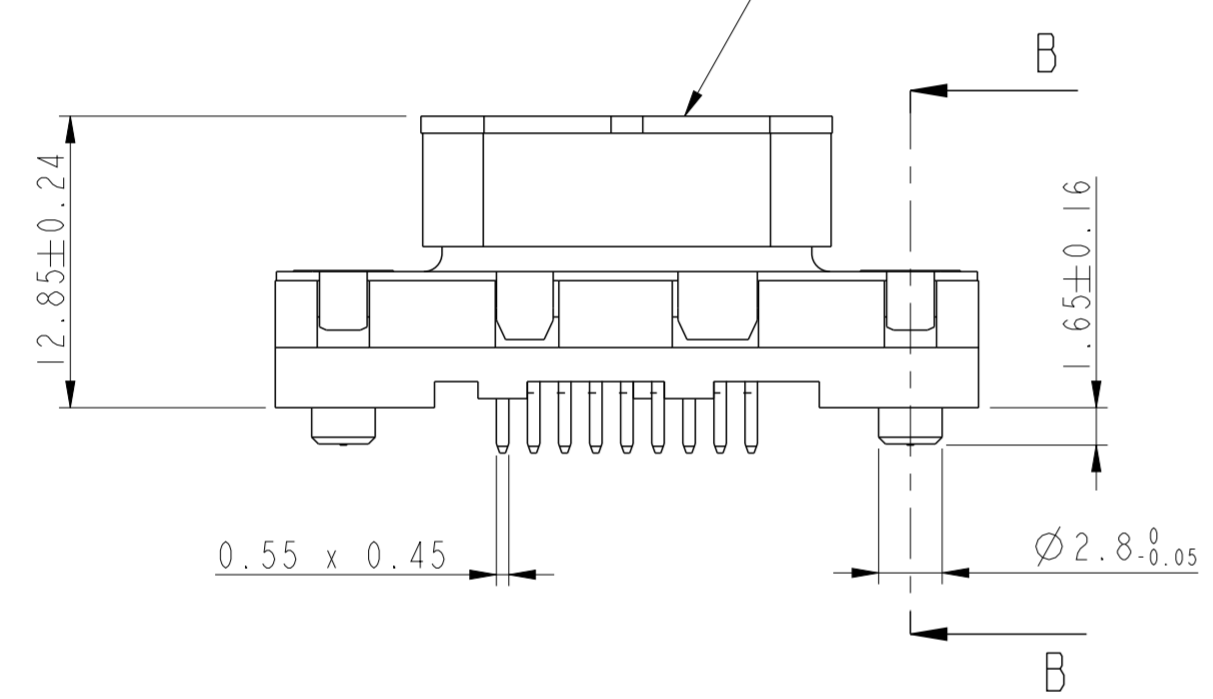
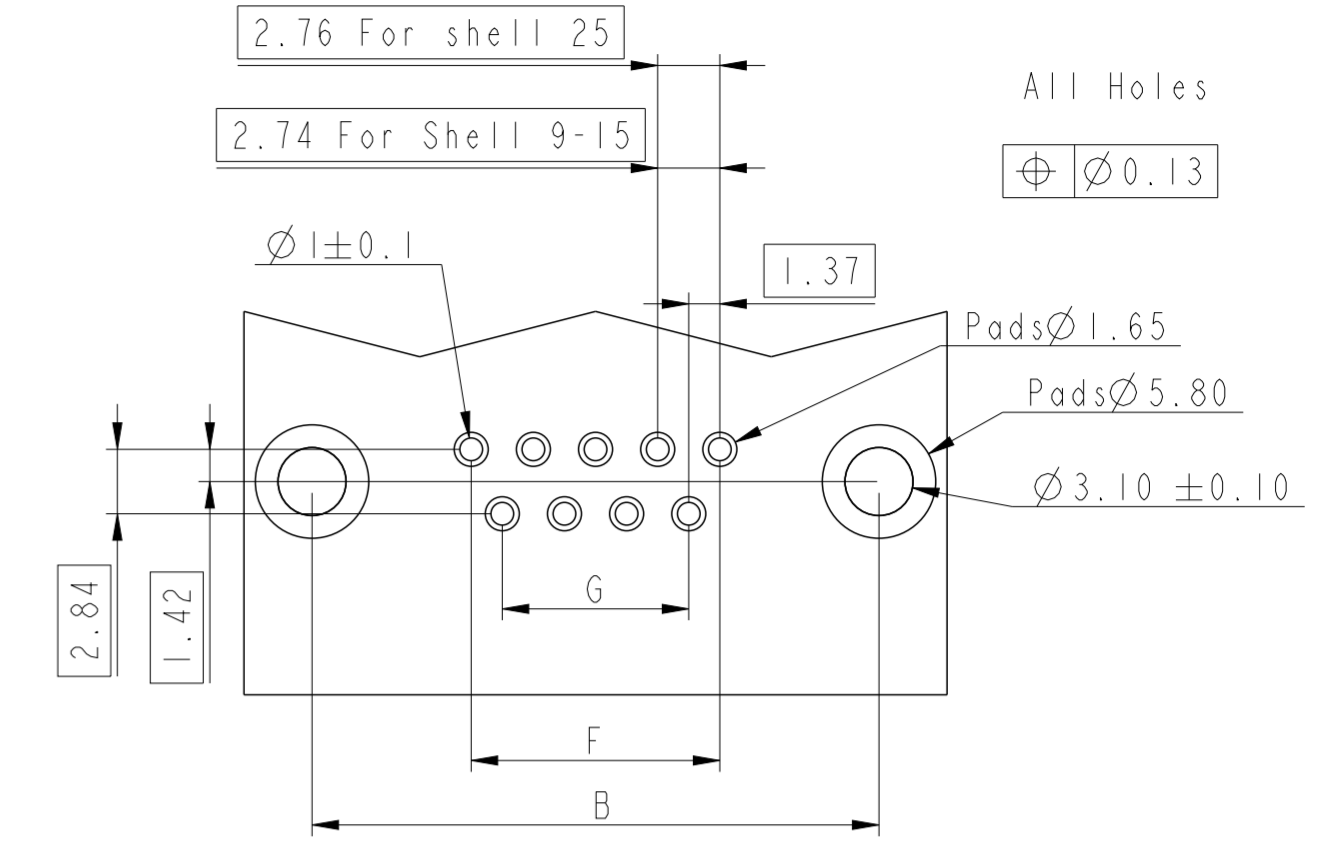
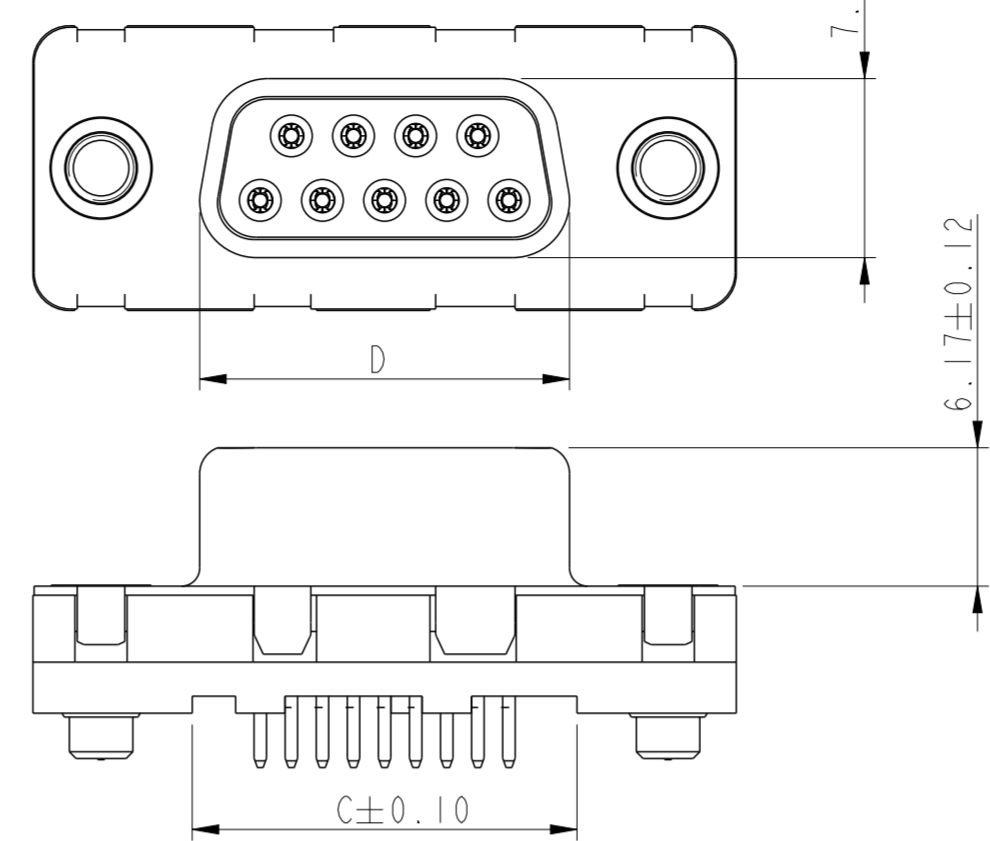
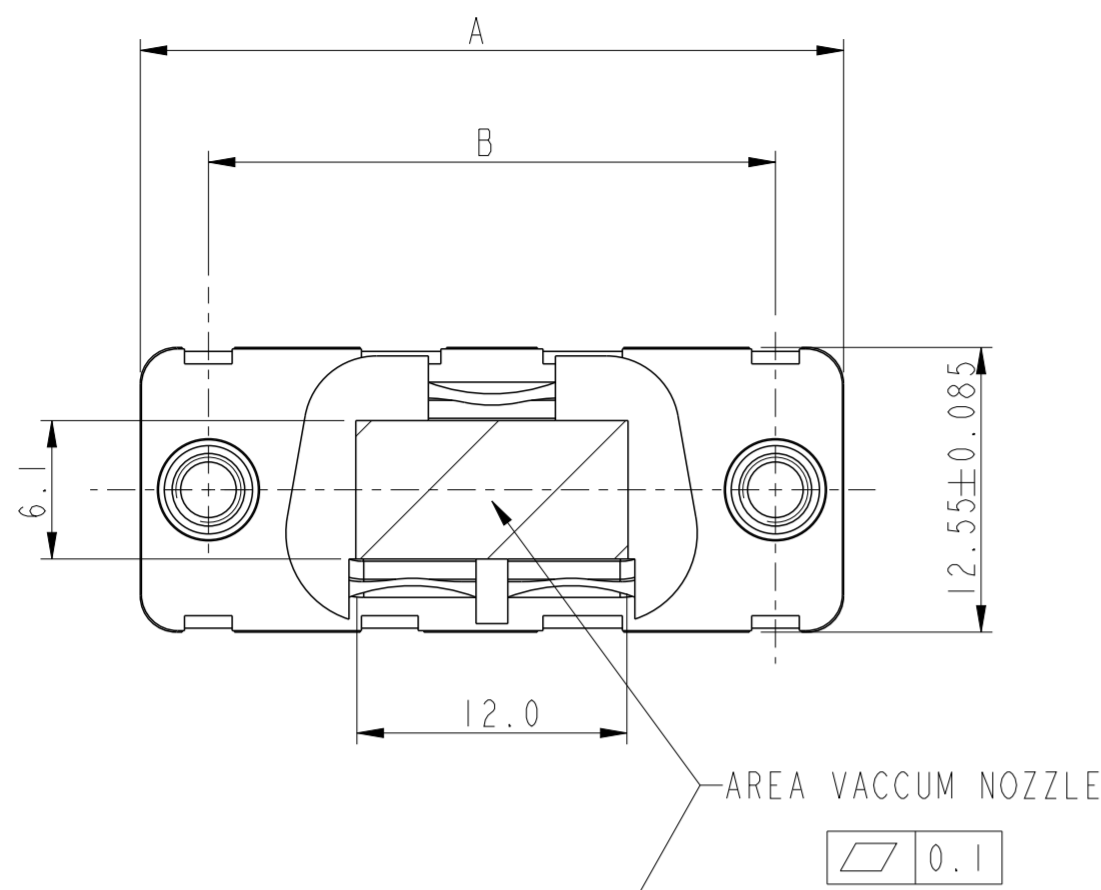

TRUE POSITIONING : $\oplus \text{ } \varnothing 0.36$

Accessories details

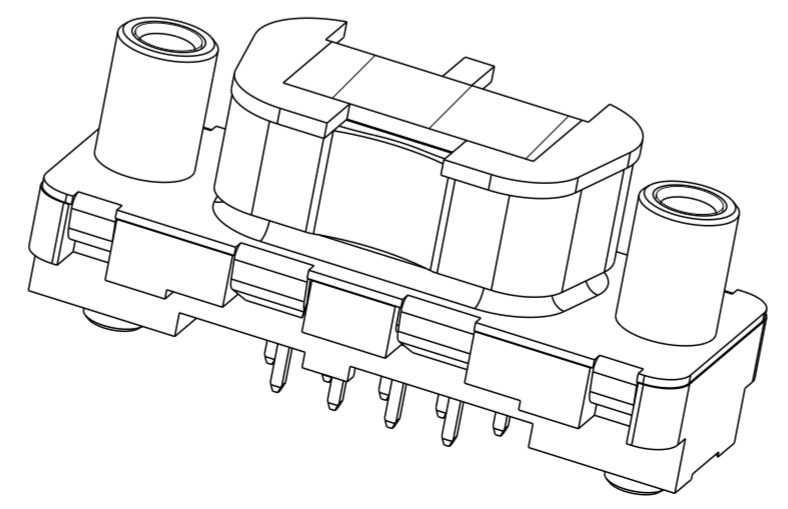
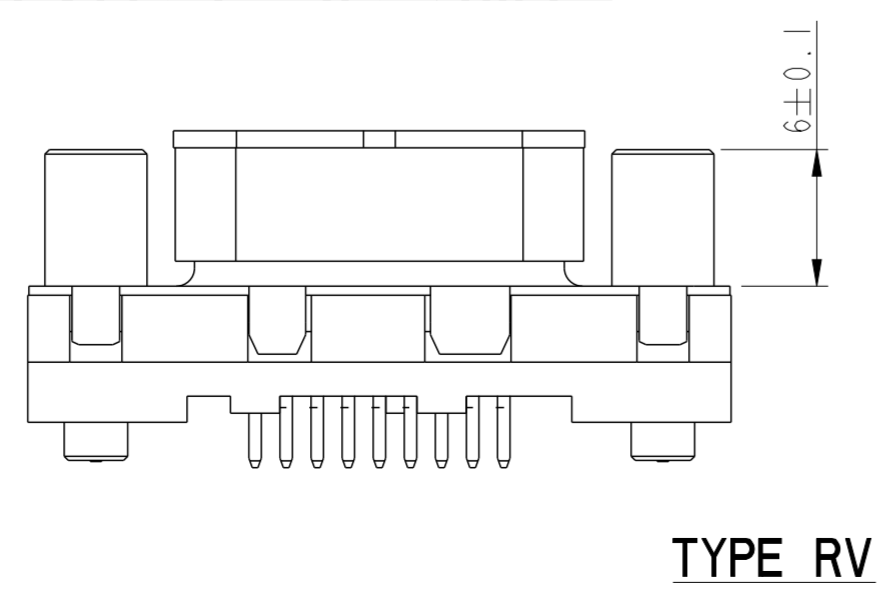
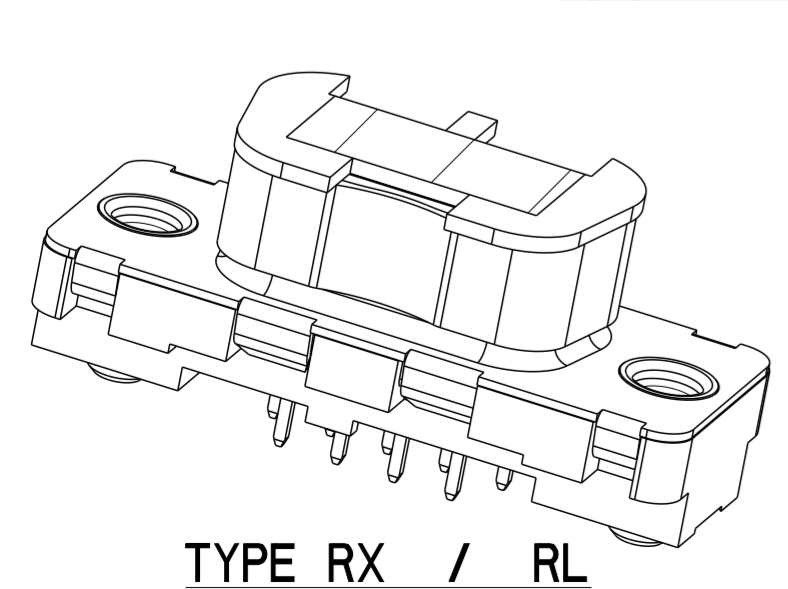

SHELL	P/N LEAD FREE	A ±0.38	B ±0.10	C ±0.10	D +0.25 0	F	G
09	D09S24A6xx22LF	30.81	24.99	16.96	16.21	10.96	8.22
15	D15S24A6xx22LF	39.14	33.32	25.18	24.54	19.18	16.44
25	D25S24A6xx22LF	53.03	47.04	39.12	38.25	33.12	30.36

www.fciconnect.com		surface	tolerance std	projection	mm
		ISO 1302	ISO 406 ISO 1101	$\oplus \text{ } \ominus$	Scale
		TOLERANCES UNLESS OTHERWISE SPECIFIED			1:1
Dr	P. CRON	02/02/06	ANGULAR	0.x	±0.3
Eng	H. LEGALLIC	02/02/06	LINEAR	0.xx	±0.1
Chr	NIRMAL G	2010-10-14	0° ±2°	0.xxx	±0.05
Appr	SUDHIR V	2010-10-14	Product family	ECN	110-0197
		Spec ref			
		title SUB DELTA D PIP FEMALE H=2 straight for tape and reel packaging		Rev. no C01-8646-0875 Rev. G	
catalog no		SEE TABLE		CUSTOMER sheet 2 of 2	

Copyright FCJ.