

PART NUMBER	REVISION	DESCRIPTION	FEED TYPE
2151927-2	E	FINE CRIMP HEIGHT ADJUST	PNEUMATIC
7-2151927-2	E	PNEUMATIC AND CRIMP TOOLING KIT	PNEUMATIC
7-2151927-7	A	CRIMP TOOLING KIT	-

ATLANTIC VERSION TERMINATOR INTERFACE ADAPTER

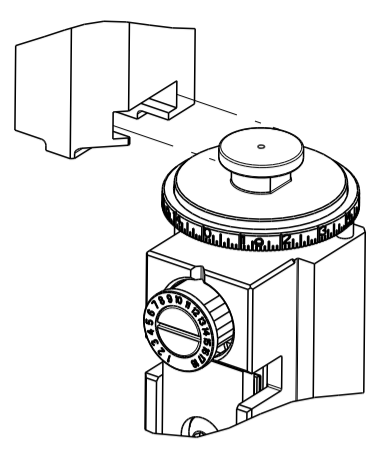

APPLICATOR DATA		
CRIMP	SIZE	TYPE
WIRE	4.20 mm [.165]	F
INSUL	6.20 mm [.244]	OV

APPLICATOR INSTRUCTIONS 408-35042

TERMINAL DATA: TE TERMINAL		TE CRIMP SPECIFICATION	
TERMINAL NAME: 8mm NGI TAB			
WIRE STRIP LENGTH		INSULATION DIAMETER RANGE	
6.50-7.50 mm [.256-.295 IN]		∅	
TERMINAL APPLICATION SPECIFICATION	114-15112	-	-

TERMINALS APPLIED				SEAL INSULATION DIAMETER RANGE
TE TERMINAL	TE TERMINAL	TE SEAL	TE SEAL	
1544332-1			1544316-1	3.35-4.30

WIRE SIZE	CRIMP HEIGHT mm [INCH]	CRIMP HEIGHT REFERENCE SETTING
6.00mm2	2.95 +/- 0.05 [.116 +/- .002]	5.3
5.00mm2	2.80 +/- 0.05 [.110 +/- .002]	7.2
4.00mm2	2.65 +/- 0.05 [.104 +/- .002]	8.6
3.00mm2	2.50 +/- 0.05 [.098 +/- .002]	10.2

- RECOMMENDED SPARE PARTS
- REFER TO SUPPLIED INSTRUCTION SHEET FOR CLEANING, LUBRICATION AND STORAGE OF APPLICATOR.
- APPLY PART NUMBER 2-23419-6 LOCTITE TO THREADS OF ITEM 242.
- CRIMP HEIGHT REFERENCE SETTING WAS THE SETTING USED WHEN THE APPLICATOR WAS QUALIFIED AT THE FACTORY. ADJUSTMENT MAY BE NECESSARY WHEN RUNNING APPLICATOR IN THE FIELD.
- TERMINAL PITCH NOT COMPATIBLE WITH MECHANICAL FEED..
- 6. UNLESS SPECIFIED OTHERWISE TORQUE VALUES SHALL BE USED PER DOCUMENT, 101-35000.
- APPLY TORQ-SEAL IN ALLEN SOCKET TO FILL HOLE AFTER FLAT HD HAS BEEN ADJUSTED TO CORRECT HEIGHT AT QUALIFICATION. APPLY #1-23419-5 LOC-TITE TO THREADS.
- CUT TO LENGTH AT ASSEMBLY.

**\*WARNING**  
 ON INSTALLATION, SET WIRE DISC TO CRIMP HEIGHT REFERENCE SETTING FOR LARGEST WIRE SIZE. CRIMP HEIGHT REFERENCE SETTINGS GREATER THAN THE VALUE SHOWN MAY CAUSE DAMAGE TO THE CRIMP TOOLING. REFER TO THE INSTRUCTION SHEET FOR PROPER SETUP AND ADJUSTMENTS.

LOC	DIST	REVISIONS					
A	66	P	LTN	DESCRIPTION	DATE	OWN	APVD
		B		ECR-18-018046	16NOV2018	TB	CT
		C		ECR-19-008843	05JUN2019	FJ	TE
		D		ECR-19-012934	16AUG2019	FJ	TE
		E		ECR-22-130189	21FEB2022	TB	RK

-	1	1	1803078-1	SPACER, PRECISION	259	
-	1	1	2119641-1	FEED CAM, AIR FEED	248	
-	1	1	2119082-6	CAM, SNAIL, INSULATION ADJUSTMENT	244	
-	1	1	2079764-1	WASHER, WAVE SPRING, CREST-TO-CREST	243	
-	1	1	2119083-1	RETAINER, INSULATION DIAL	242	
-	1	1	2844940-2	AIR FEED MODULE	238	
-	REF	REF	994970-2	COUNTER, MAGNETIC	164	
-	1	1	2844908-1	SCREW, LOCKING	99	
-	1	1	2844907-1	POST, LOCKING	98	
-	1	1	455888-6	SPACER, CRIMPER	82	
-	2	2	2079383-4	SCR, BHSC, RoHS (M4 X 8)	79	
-	1	1	1803096-1	EXTENSION PLATE	78	
-	1	1	1803607-3	DOCUMENTATION PACKAGE	71	
-	1	1	2119740-1	TAG, IDENTIFICATION	67	
-	2	2	2168078-1	SCREW, DRIVE, RH, RoHS, 2 x .188	66	
-	1	1	2168083-2	SCR, SKT HD CAP, RoHS, M4 X 8.0	60	
-	1	1	5-18022-5	SCR, HEX HD CAP, M4 X 6.0	59	
-	1	1	985575-5	SCR, FLT SKT HD CAP M3 X 16.0	57	
-	1	1	1-1338683-1	FEED PAWL	56	
-	4	4	2168083-3	SCR, SKT HD CAP, RoHS, M4 X 12.0	54	
-	2	2	1-2168083-0	SCR, SKT HD CAP, RoHS, M4 X 10	53	
-	1	1	5018030-1	NUT, HEX, REG, RoHS, M3	52	
-	1	1	811242-5	BUMPER, HOLD DOWN	51	
-	1	1	690753-2	SPACER, TONKER	50	
-	1	1	18023-9	SCR, SKT HD CAP M4 X 6.0	49	
-	1	1	1-1803583-7	APPLICATOR BASIC ASSEMBLY, SF	46	
-	1	1	1803515-2	RAM ASSEMBLY, SF ATLANTIC	44	
-	1	1	1803602-2	SCR, BHSC, RoHS (M8 X 40)	41	
-	1	1	1-1752356-9	SUPPORT, TERMINAL	34	
-	2	2	2079383-8	SCR, BHSC, RoHS (M4 X 16)	33	
-	2	2	2-2844962-6	SPACER, CYLINDRICAL, STRIP GUIDE	30	
-	1	1	2844992-5	ASSEMBLY, STRIP GUIDE	29	
-	1	1	455888-3	SPACER, CRIMPER	28	
-	2	2	22281-8	SPRING, COMPRESSION	27	
-	1	1	240792-1	DRAG, TERMINAL	25	
-	1	1	1320928-4	STRIP GUIDE	24	
-	1	1	1-690438-0	FRONT STRIP GUIDE	23	
-	1	1	2168083-2	SCR, SKT HD CAP, RoHS, M4 X 8.0	21	
-	2	2	1-18028-2	WASHER, FLAT, REG M4	20	
-	1	1	1803013-1	STRIPPER, SIDE FEED	18	
-	1	1	3-22280-3	SPRING, COMPRESSION	12	
-	1	1	1-356885-3	STOP, SHEAR	11	
-	1	1	1-2119805-2	SHEAR HOLDER, FRONT	10	
-	1	1	1-318059-0	FLOATING SHEAR, FRONT	9	
-	1	2	1	4-1633927-9	ANVIL, COMBINATION	8
-	-	-	-	-	7	
-	-	-	-	-	6	
-	1	1	1803080-1	DEPRESSOR, SHEAR	5	
-	1	1	4-238011-4	BLOCK, CRIMPER SPACER	4	
-	1	2	1	1803111-1	CRIMPER, INSULATION OVERLAP PREMIUM	3
-	1	1	2-455888-2	SPACER, CRIMPER	2	
-	1	2	1	4-1633730-8	CRIMPER, WIRE	1

DIMENSIONS:		TOLERANCES UNLESS OTHERWISE SPECIFIED:		MATERIAL:		FINISH:		WEIGHT:		SCALE:		SHEET:		REV:	
mm	0 PLC ±	1 PLC ±	2 PLC ±	3 PLC ±	4 PLC ±	ANGLES	FINISH			A	00779	1	OF	4	E

ATLANTIC VERSION  
 Shown on sheets 1 of 4 & 2 of 4  
 (Pacific version shown on sheets 3 of 4 & 4 of 4)

LOC	DIST	REVISIONS			
P	LTN	DESCRIPTION	DATE	OWN	APVD
A	66	SEE SHEET 1	-	-	-

### FEED TYPE PNEUMATIC

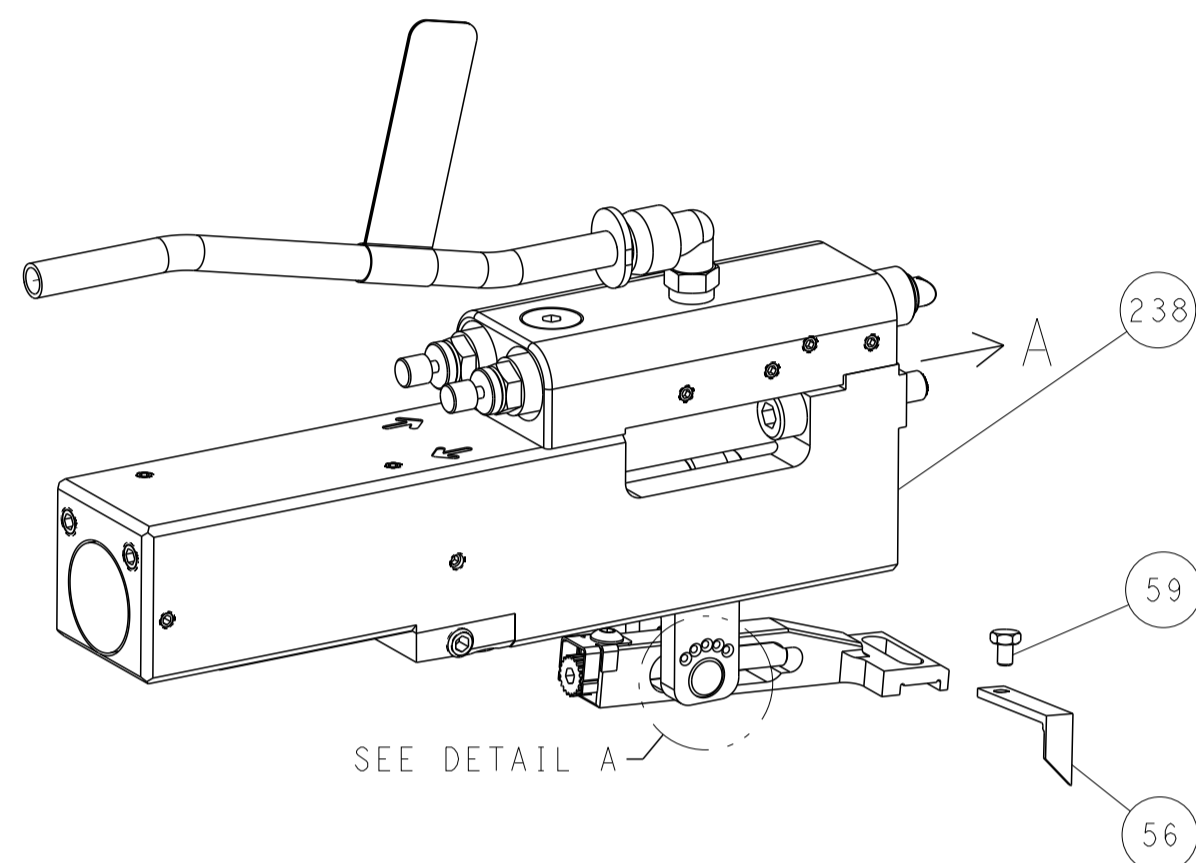

SEE DETAIL A

### FEED SPRING SETTING POSITION (SHOWN FROM REAR SIDE)

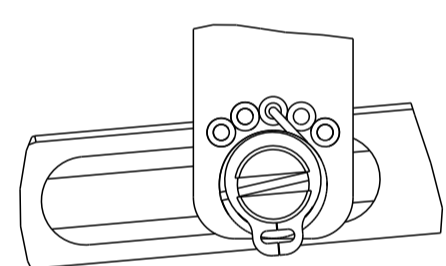

DETAIL A

### CAM POSITION

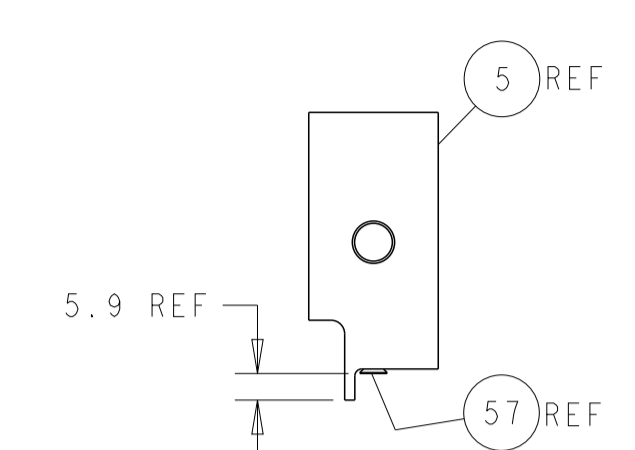
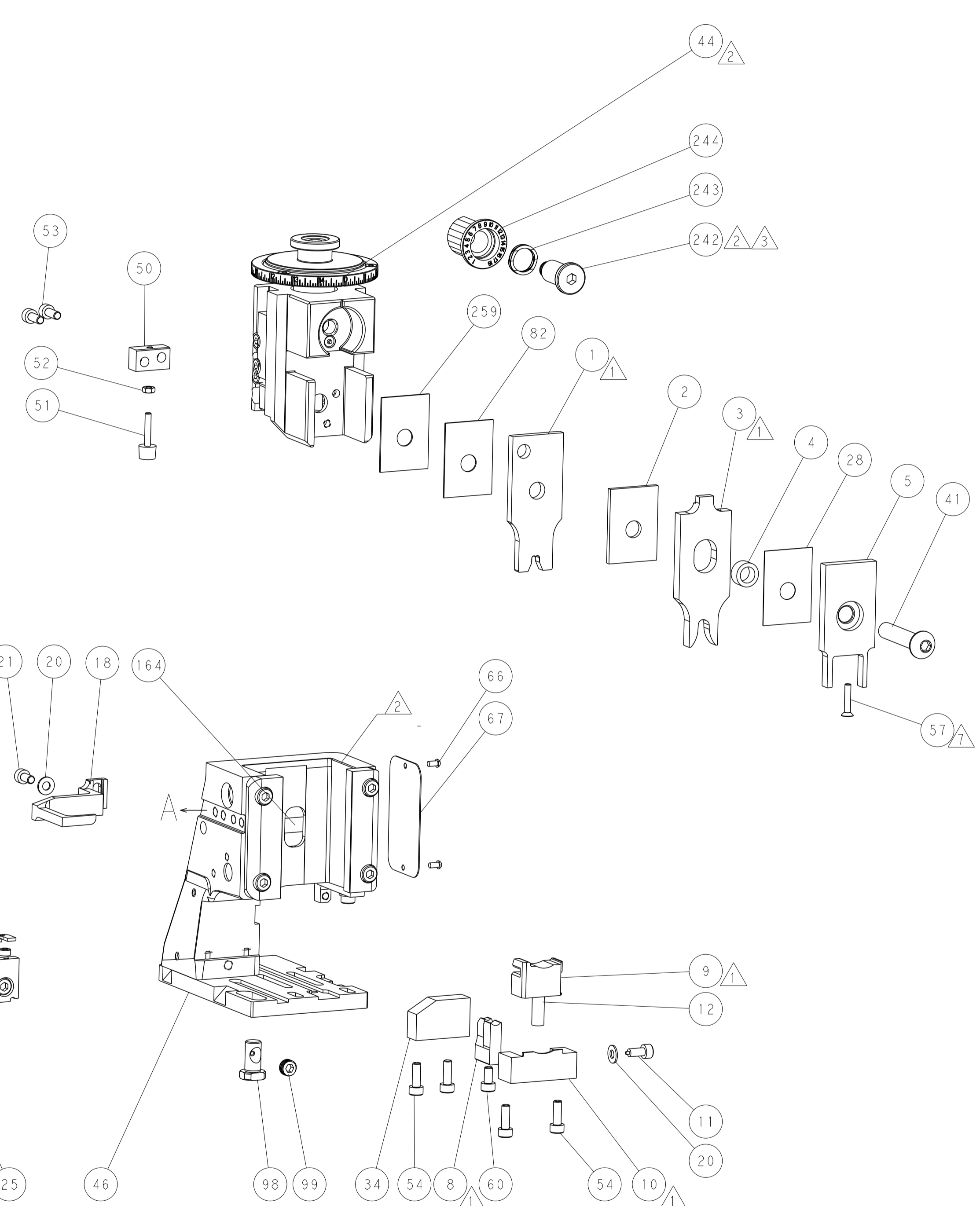
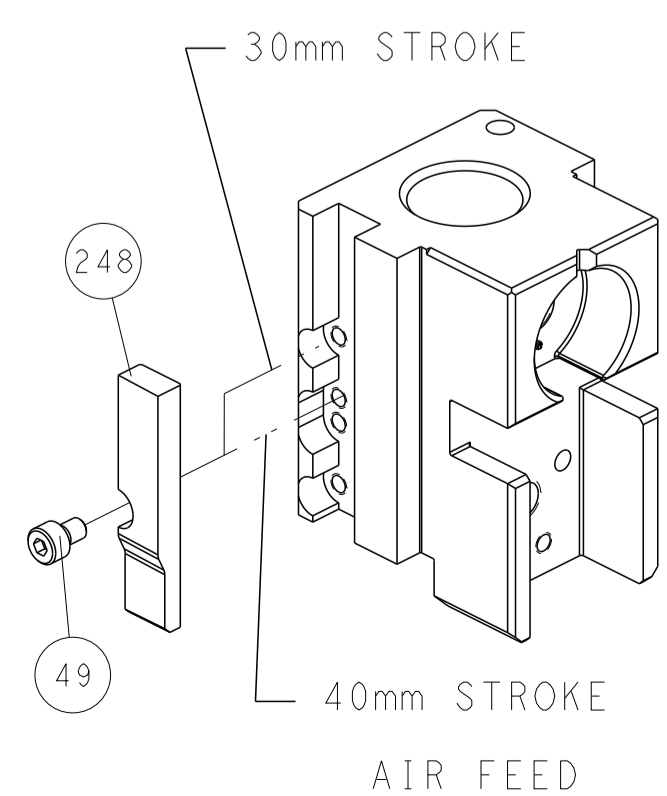

SHEAR DEPRESSOR DETAIL

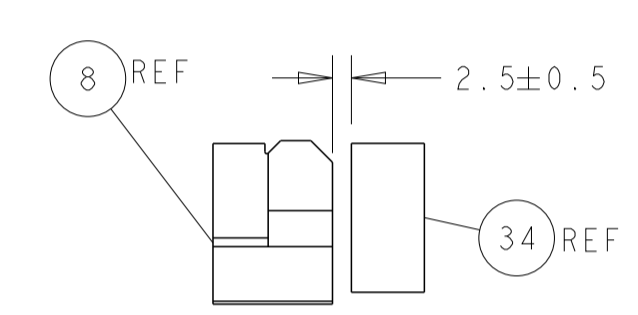

TERMINAL SUPPORT LOCATION

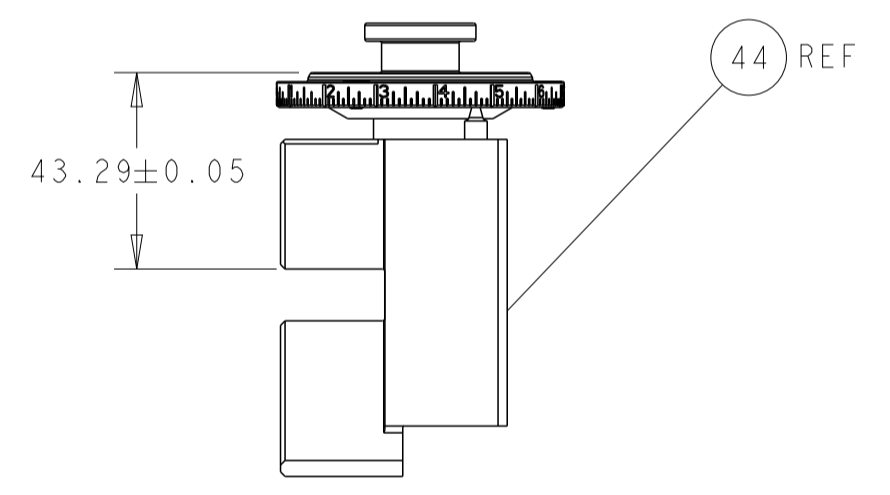

RAM SET-UP

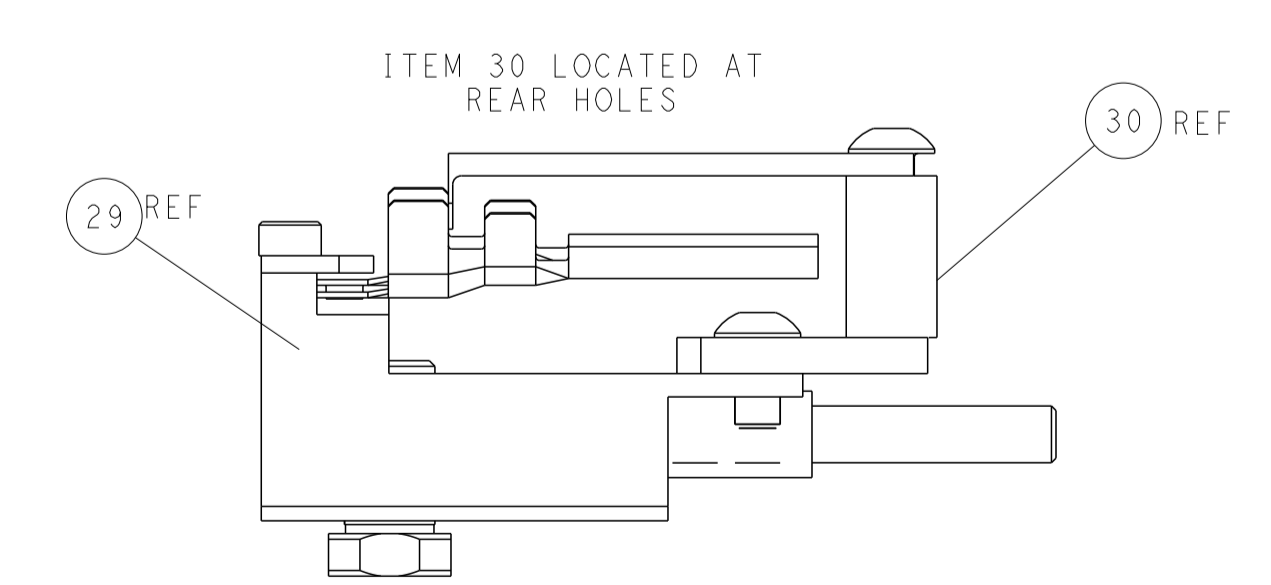

FEED TRACK POSITION  
GUIDE BY INSULATION BARREL

**ATLANTIC VERSION**  
 Shown on sheets 1 of 4 & 2 of 4  
 (Pacific version shown on sheets 3 of 4 & 4 of 4)

DIMENSIONS:		TOLERANCES UNLESS OTHERWISE SPECIFIED:		OWN: BOB HIGMAN 13JUN2013		TE Connectivity	
mm	0 PLC ±	1 PLC ±	2 PLC ±	3 PLC ±	4 PLC ±	Harrisburg, PA 17105-3608	
ANGLES	FINISH	MATERIAL:		APVD: M. CLIFFORD 13JUN2013		NAME: Ocean Side Feed Applicator	
MATERIAL:		FINISH:		WEIGHT:		SIZE: A1 00779 C=2151927	
Customer Accessible Production Drawing		SCALE: 1:2		SHEET: 2 of 4		REV: E	

THIS DRAWING IS UNPUBLISHED.	RELEASED FOR PUBLICATION		
COPYRIGHT 20 BY TYCO ELECTRONICS CORPORATION. ALL RIGHTS RESERVED.			
PART NUMBER	REVISION	DESCRIPTION	FEED TYPE
2-2151927-2	E	FINE CRIMP HEIGHT ADJUST	PNEUMATIC
7-2151927-7	A	CRIMP TOOLING KIT	-

PACIFIC VERSION TERMINATOR  
INTERFACE ADAPTER

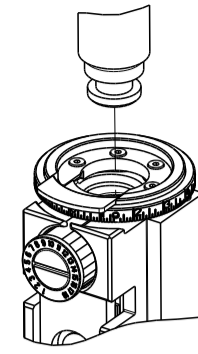

APPLICATOR DATA		
CRIMP	SIZE	TYPE
WIRE	4.20 mm [1.65]	F
INSUL	6.20 mm [2.44]	OV
APPLICATOR INSTRUCTIONS 408-35042		

TERMINAL DATA: TE TERMINAL		TE CRIMP SPECIFICATION	
TERMINAL NAME: 8mm NGI TAB			
WIRE STRIP LENGTH 6.50-7.50 mm [2.56-.295 IN]		INSULATION DIAMETER RANGE Ø	
TERMINAL APPLICATION SPECIFICATION 114-15112			
TERMINALS APPLIED			
TE TERMINAL	TE TERMINAL	TE SEAL	TE SEAL
1544332-1			1544316-1
		SEAL INSULATION DIAMETER RANGE 3.35-4.30	

WIRE SIZE	CRIMP HEIGHT mm [INCH]	CRIMP HEIGHT REFERENCE SETTING
6.00mm2	2.95+/-0.05 [1.16+/-0.02]	5.3
5.00mm2	2.80+/-0.05 [1.10+/-0.02]	7.2
4.00mm2	2.65+/-0.05 [1.04+/-0.02]	8.6
3.00mm2	2.50+/-0.05 [0.98+/-0.02]	10.2

- RECOMMENDED SPARE PARTS
- REFER TO SUPPLIED INSTRUCTION SHEET FOR CLEANING, LUBRICATION AND STORAGE OF APPLICATOR.
- APPLY PART NUMBER 2-23419-6 LOCTITE TO THREADS OF ITEM 242.
- CRIMP HEIGHT REFERENCE SETTING WAS THE SETTING USED WHEN THE APPLICATOR WAS QUALIFIED AT THE FACTORY. ADJUSTMENT MAY BE NECESSARY WHEN RUNNING APPLICATOR IN THE FIELD.
- TERMINAL PITCH NOT COMPATIBLE WITH MECHANICAL FEED.
- UNLESS SPECIFIED OTHERWISE TORQUE VALUES SHALL BE USED PER DOCUMENT, 101-35000.
- APPLY TORQ-SEAL IN ALLEN SOCKET TO FILL HOLE AFTER FLAT HD HAS BEEN ADJUSTED TO CORRECT HEIGHT AT QUALIFICATION. APPLY #1-23419-5 LOC-TITE TO THREADS.
- CUT TO LENGTH AT ASSEMBLY.

**\*WARNING**  
ON INSTALLATION, SET WIRE DISC TO CRIMP HEIGHT REFERENCE SETTING FOR LARGEST WIRE SIZE. CRIMP HEIGHT REFERENCE SETTINGS GREATER THAN THE VALUE SHOWN MAY CAUSE DAMAGE TO THE CRIMP TOOLING. REFER TO THE INSTRUCTION SHEET FOR PROPER SETUP AND ADJUSTMENTS.

LOC	DIST	REV	DATE	BY	APPROV
A	66				

REV	DATE	BY	APPROV	
-	1	1803078-1	SPACER, PRECISION	259
-	1	2119082-6	CAM, SNAIL, INSULATION ADJUSTMENT	244
-	1	2079764-1	WASHER, WAVE SPRING, CREST-TO-CREST	243
3	-	2119083-1	RETAINER, INSULATION DIAL	242
-	1	2844940-2	AIR FEED MODULE	238
-	REF	994970-2	COUNTER, MAGNETIC	164
-	1	2119641-2	FEED CAM, AIR FEED	151
-	1	2168083-8	SCR, SKT HD CAP, RoHS, M4 X 16	144
-	4	2168083-9	SCR, SKT HD CAP, RoHS, M4 X 20	143
-	1	1-1803583-8	APPLICATOR BASIC ASSEMBLY, SF	141
-	1	1803516-2	RAM ASSEMBLY, SF PACIFIC	140
-	1	2844908-1	SCREW, LOCKING	99
-	1	2844907-1	POST, LOCKING	98
-	1	455888-6	SPACER, CRIMPER	82
8	-	2079383-4	SCR, BHSC, RoHS (M4 X 8)	79
-	1	1803096-1	EXTENSION PLATE	78
-	1	1803607-3	DOCUMENTATION PACKAGE	71
-	1	2119740-1	TAG, IDENTIFICATION	67
-	2	2168078-1	SCREW, DRIVE, RH, RoHS, 2 x .188	66
-	1	5-18022-5	SCR, HEX HD CAP, M4 X 6.0	59
7	-	985575-5	SCR, FLT SKT HD CAP M3 X 16.0	57
-	1	1-1338683-1	FEED PAWL	56
-	2	1-2168083-0	SCR, SKT HD CAP, RoHS, M4 X 10	53
-	1	5018030-1	NUT, HEX, REG, RoHS, M3	52
-	1	811242-5	BUMPER, HOLD DOWN	51
-	1	690753-2	SPACER, TONKER	50
-	1	18023-9	SCR, SKT HD CAP M4 X 6.0	49
-	1	1803602-2	SCR, BHSC, RoHS (M8 X 40)	41
-	1	1-1752356-9	SUPPORT, TERMINAL	34
-	2	2079383-8	SCR, BHSC, RoHS (M4 X 16)	33
-	2	2-2844962-6	SPACER, CYLINDRICAL, STRIP GUIDE	30
-	1	2844992-5	ASSEMBLY, STRIP GUIDE	29
-	1	455888-3	SPACER, CRIMPER	28
-	2	22281-8	SPRING, COMPRESSION	27
-	1	240792-1	DRAG, TERMINAL	25
-	1	1320928-4	STRIP GUIDE	24
-	1	1-690438-0	FRONT STRIP GUIDE	23
-	1	2168083-2	SCR, SKT HD CAP, RoHS, M4 X 8.0	21
-	2	1-18028-2	WASHER, FLAT, REG M4	20
-	1	1803013-1	STRIPPER, SIDE FEED	18
-	1	3-22280-3	SPRING, COMPRESSION	12
-	1	1-356885-3	STOP, SHEAR	11
1	-	1-2119805-2	SHEAR HOLDER, FRONT	10
1	-	1-318059-0	FLOATING SHEAR, FRONT	9
1	1	4-1633927-9	ANVIL, COMBINATION	8
-	-	-	-	7
-	-	-	-	6
-	1	1803080-1	DEPRESSOR, SHEAR	5
-	1	4-238011-4	BLOCK, CRIMPER SPACER	4
1	1	1803111-1	CRIMPER, INSULATION OVERLAP PREMIUM	3
-	1	2-455888-2	SPACER, CRIMPER	2
1	1	4-1633730-8	CRIMPER, WIRE	1

PACIFIC VERSION  
Shown on sheets 3 of 4 & 4 of 4  
(Atlantic version shown on sheets 1 of 4 & 2 of 4)

DIMENSIONS:		TOLERANCES UNLESS OTHERWISE SPECIFIED:		DWG: BOB HIGMAN 13JUN2013		REV: T. ELBIN 13JUN2013	
mm	0 PLC ±	1 PLC ±	2 PLC ±	NAME: M. CLIFFORD 13JUN2013		TE Connectivity Harrisburg, PA 17105-3608	
	3 PLC ±	4 PLC ±	ANGLES ±	PRODUCT SPEC		Ocean Side Feed Applicator	
MATERIAL:	FINISH:	WEIGHT:	SCALE:	SIZE: A1		CAGE CODE: 00779	
				DRAWING NO: 2151927		SHEET 3 OF 4	
Customer Accessible Production Drawing				REV E			

LOC	DIST	REVISIONS					
		P	LTN	DESCRIPTION	DATE	OWN	APVD
A	66	-	-	SEE SHEET 1	-	-	-

### FEED TYPE PNEUMATIC

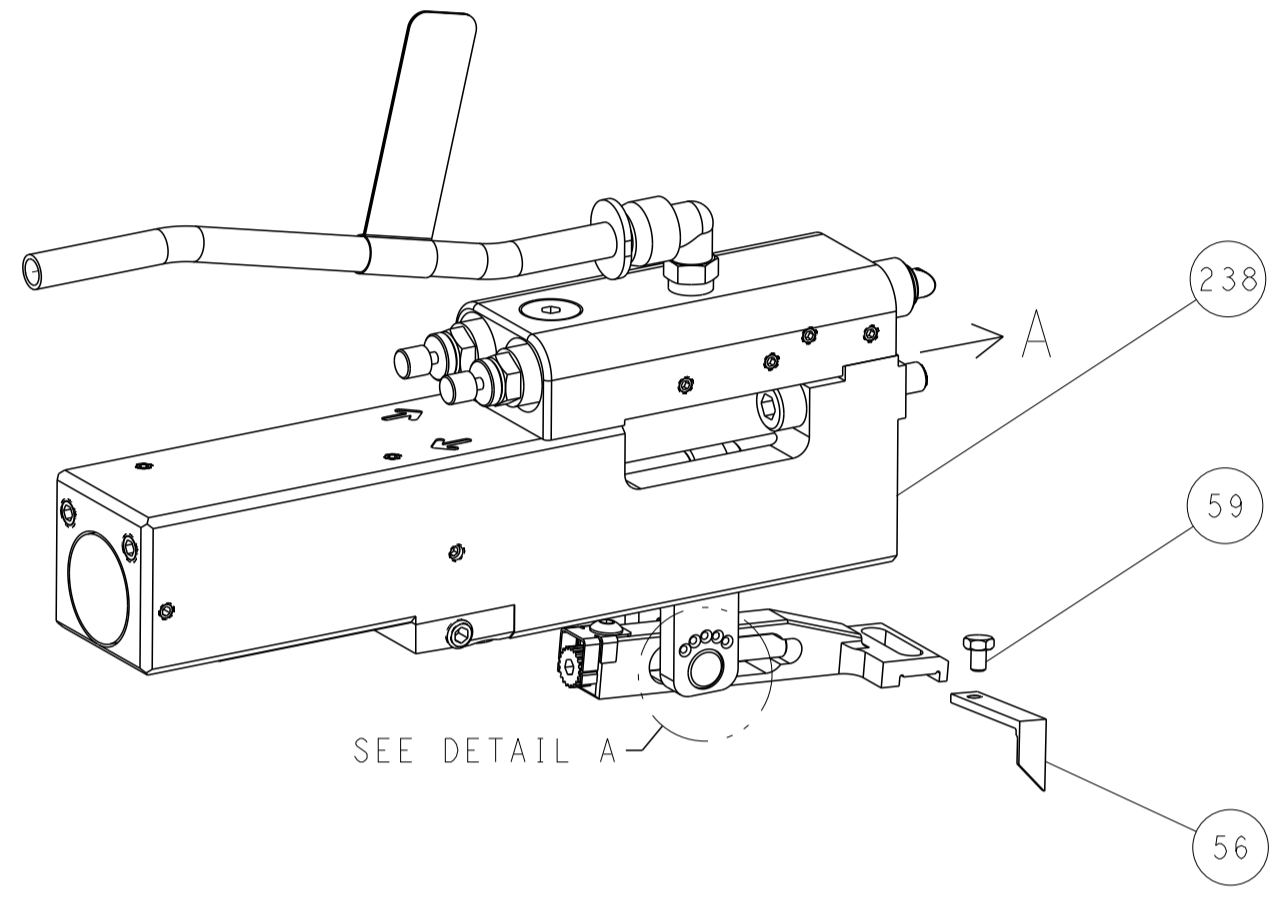

SEE DETAIL A

### FEED SPRING SETTING POSITION (SHOWN FROM REAR SIDE)

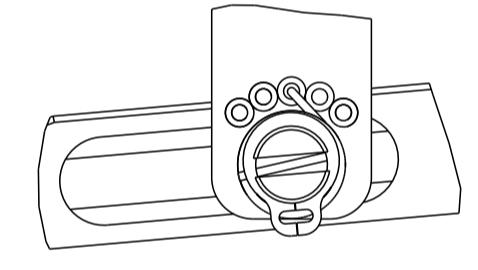

DETAIL A

### CAM POSITION

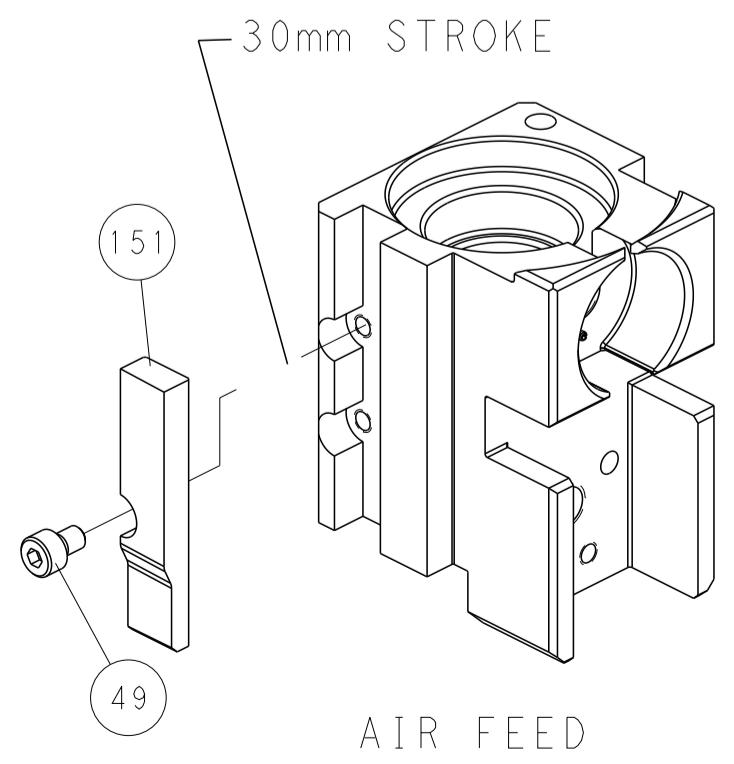

AIR FEED

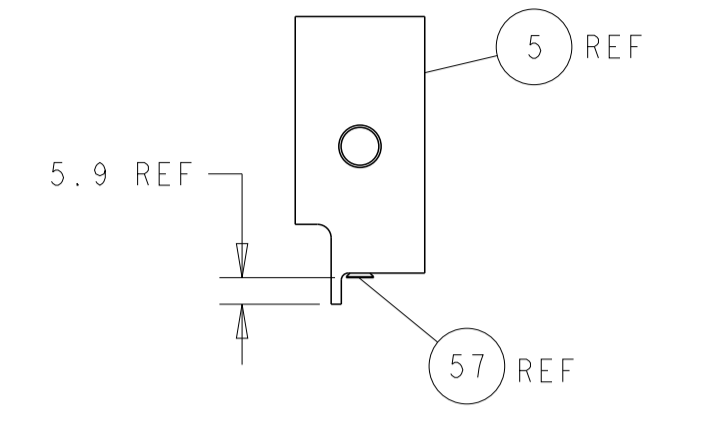
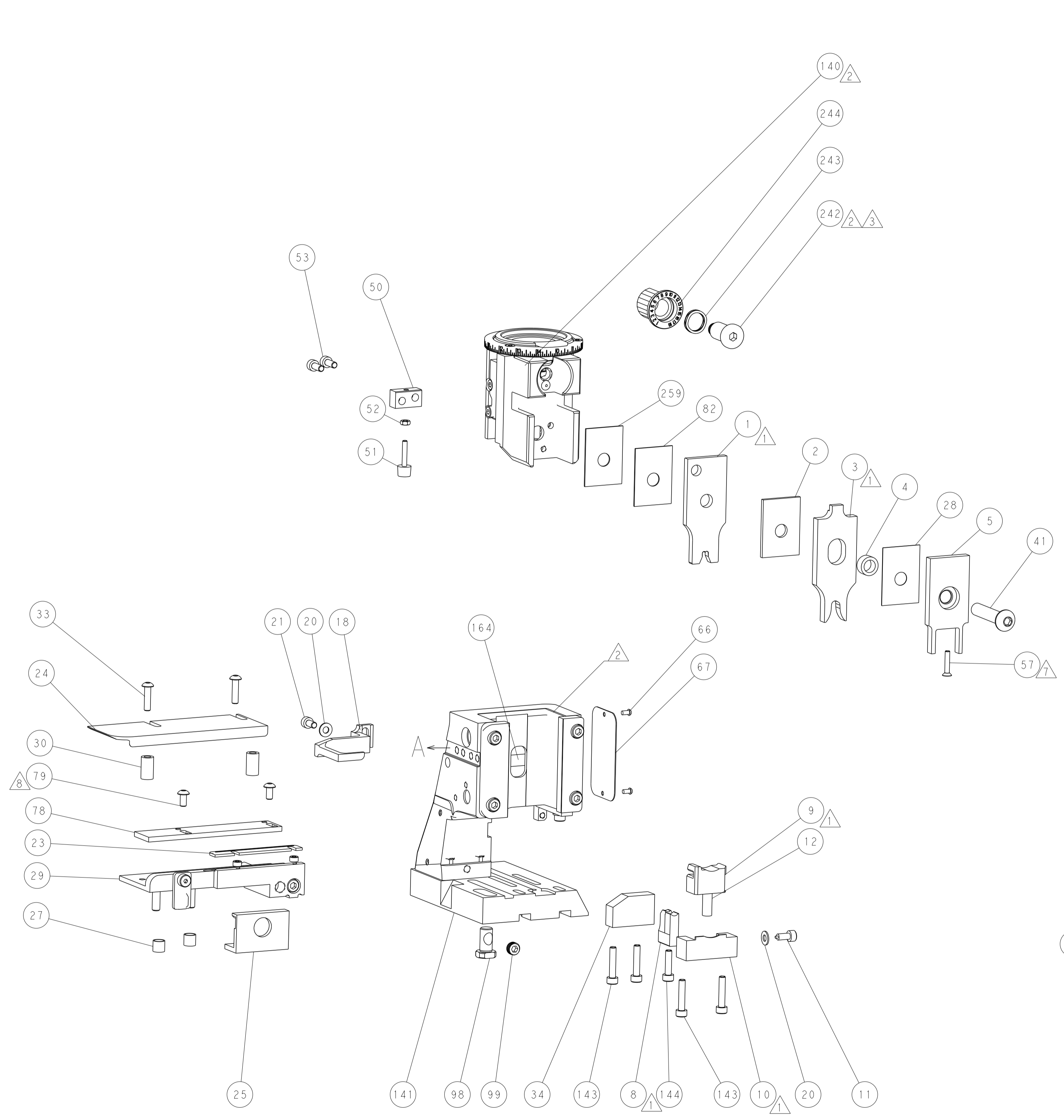

SHEAR DEPRESSOR DETAIL

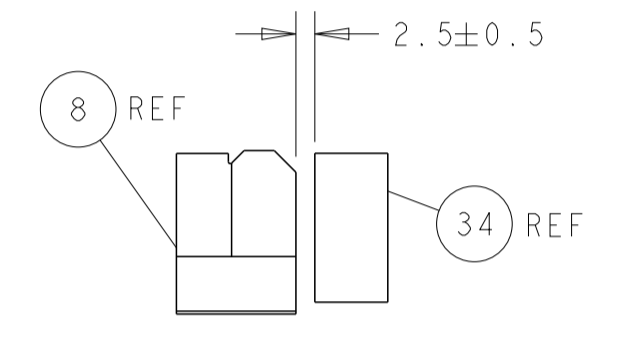

TERMINAL SUPPORT LOCATION

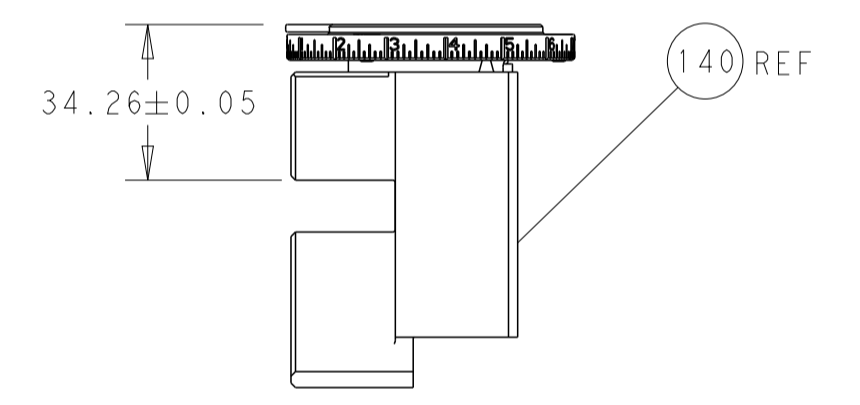

RAM SET-UP

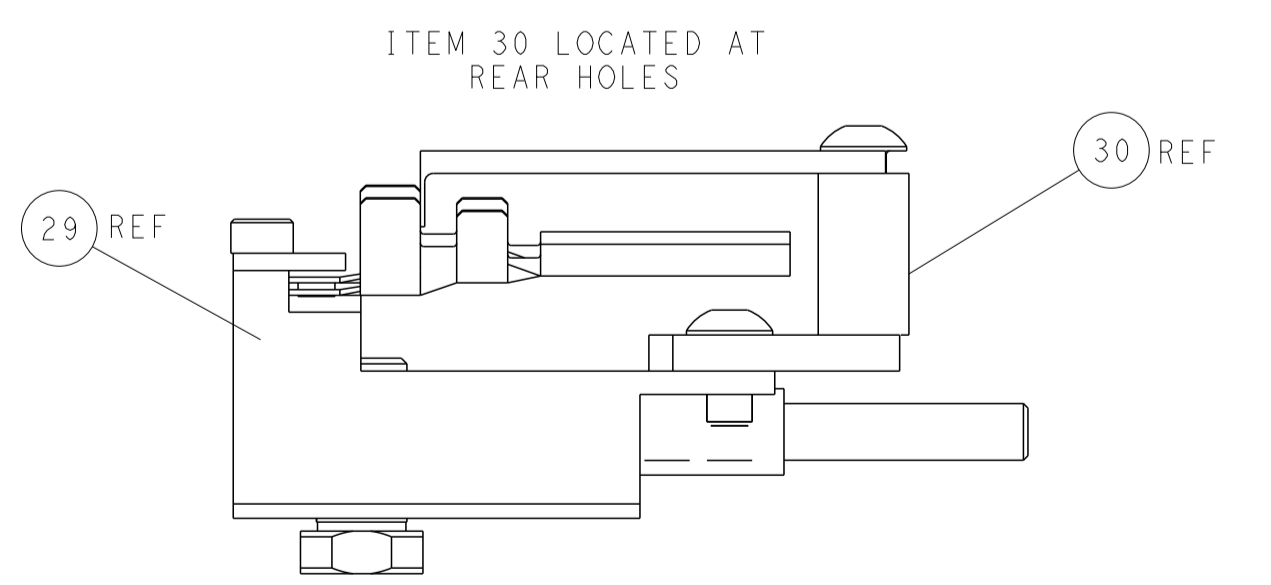

FEED TRACK POSITION  
GUIDE BY INSULATION BARREL

**PACIFIC VERSION**  
 Shown on sheets 3 of 4 & 4 of 4  
 (Atlantic version shown on sheets 1 of 4 & 2 of 4)

<small>THIS DRAWING IS UNPUBLISHED. RELEASED FOR PUBLICATION. ALL RIGHTS RESERVED. THIS DRAWING IS THE PROPERTY OF TYCO ELECTRONICS CORPORATION. IT IS TO BE USED ONLY FOR THE PURPOSES AND IN THE QUANTITIES SPECIFIED IN THE ORDER. IT IS NOT TO BE REPRODUCED OR TRANSMITTED IN ANY FORM OR BY ANY MEANS, ELECTRONIC OR MECHANICAL, WITHOUT THE WRITTEN PERMISSION OF TYCO ELECTRONICS CORPORATION.</small>		DWN BOB HIGMAN 13JUN2013 CHK T. ELBIN 13JUN2013 APVD M. CLIFFORD 13JUN2013	TE Connectivity Harrisburg, PA 17105-3608
DIMENSIONS: mm TOLERANCES UNLESS OTHERWISE SPECIFIED: 0 PLC ±. 1 PLC ±. 2 PLC ±. 3 PLC ±. 4 PLC ±. ANGLES ±. MATERIAL: . FINISH: .		NAME: Ocean Side Feed Applicator PRODUCT SPEC: . APPLICATION SPEC: . WEIGHT: . SCALE: 1:2	SIZE: A1 CAGE CODE: 00779 DRAWING NO: 2151927 SHEET 4 OF 4 REV E