

Evaluating the **ADPD188BI** Optical Module

FEATURES

Supports the detection of UART
UDP transfer capability
Full configuration of the **ADPD188BI**
Register level
High level
Graph view
Time graph
Frequency graph

EVALUATION KIT CONTENTS

EVAL-ADPD188BIZ-SK evaluation board
Ribbon cable

ADDITIONAL EQUIPMENT NEEDED

PC running Windows 7 or Windows 10 operating system
EVAL-ADPDUZC microcontroller board

ONLINE RESOURCES

ADPD188BI data sheet
Applications WaveTool software package

GENERAL DESCRIPTION

The EVAL-ADPD188BIZ-SK evaluation board provides users with a simple means of evaluating the **ADPD188BI** optical module for smoke and aerosol detection applications. The evaluation system includes the **Applications WaveTool** graphical user interface (GUI), providing users with low level and high level configurability, real-time frequency and time domain analysis, and user datagram protocol (UDP) transfer capability so that the evaluation board can easily interface to the user development system.

The EVAL-ADPD188BIZ-SK is powered through the ribbon cable from the **EVAL-ADPDUZC** microcontroller board, obtained separately.

For additional information on the functionality of the **ADPD188BI**, refer to the **ADPD188BI** data sheet.

EVALUATION BOARD PHOTOGRAPH

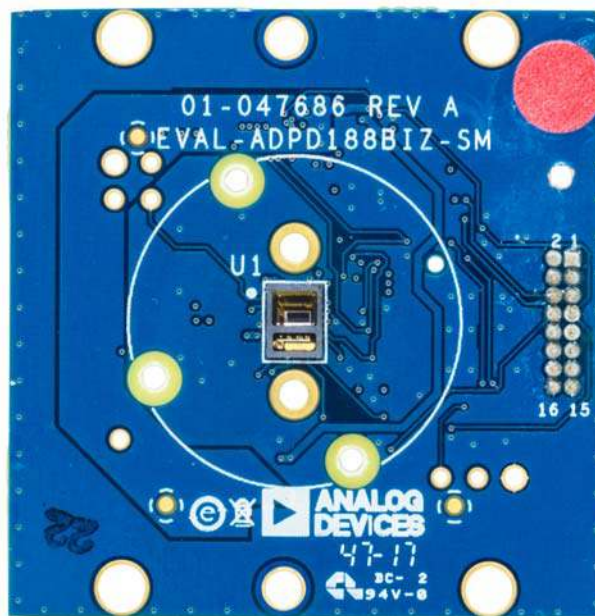

Figure 1.

TABLE OF CONTENTS

Features	1	Checking the USB Serial Connection in Windows	3
Evaluation Kit Contents.....	1	Running the Applications WaveTool.....	3
Additional Equipment Needed	1	Instructions to Load the Firmware	3
Online Resources	1	USB UART Connection.....	4
General Description	1	Acquiring Data.....	5
Evaluation Board Photograph.....	1	Selecting the Proper View	5
Revision History	2	Load Configuration	5
Getting Started	3	Optimizing and Running the ADPD188BI	5
Installing the Applications WaveTool.....	3	Evaluation Board Schematics and Artwork.....	8
Connecting the EVAL-ADPDUCZ Microcontroller Board and the EVAL-ADPD188BIZ-SK Evaluation Board.....	3		

REVISION HISTORY

6/2018—Revision 0: Initial Version

GETTING STARTED

INSTALLING THE APPLICATIONS WAVETOOL

Download the [Applications WaveTool](#) software package from the EVAL-ADPD188BIZ-SK product page. Unzip the folder and run [Applications_WaveTool_x_x.exe](#). Follow the prompts for software installation, beginning with the setup window shown in Figure 2.



Figure 2. Applications WaveTool Setup Window

CONNECTING THE EVAL-ADPDCUZ MICROCONTROLLER BOARD AND THE EVAL-ADPD188BIZ-SK EVALUATION BOARD

Connect the USB cable to the [EVAL-ADPDCUZ](#) evaluation board, connect the ribbon cable to the EVAL-ADPD188BIZ-SK board, and switch the power switch to the ON position (see Figure 3).

When the USB cable is connected, the second light emitting diode (LED) below the power switch illuminates, indicating that the on-board battery is being charged. When the power switch is turned to the ON position, the LED immediately below the power switch illuminates, indicating that the [EVAL-ADPDCUZ](#) microcontroller board is on.

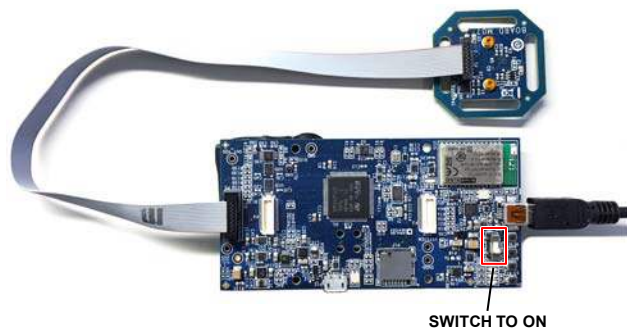

Figure 3. Connecting the EVAL-ADPDCUZ to the EVAL-ADPD188BIZ-SK

CHECKING THE USB SERIAL CONNECTION IN WINDOWS

Ensure that the COM port driver is installed correctly. To verify proper installation of the COM port driver, go to **Control Panel > All Control Panel Items > System > Device Manager**, as shown in Figure 4. In this case, the proper COM port selection is **USB Serial Port (COM16)**.

The EVAL-ADPDCUZ microcontroller board uses an FT232 USB universal asynchronous receiver transmitter (UART) IC. If the USB driver installation does not install properly, refer to the corresponding FTDI driver installation guide that is compatible with the operating system being used.

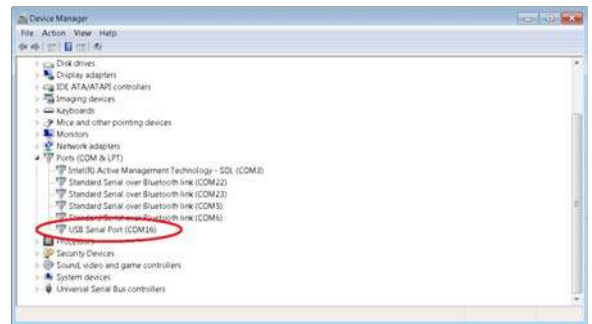

Figure 4. USB Serial Port in Windows® 7

The [EVAL-ADPDCUZ](#) also contains a Bluetooth® radio that can be paired with the PC if a wireless connection is desired.

RUNNING THE APPLICATIONS WAVETOOL

To start the [Applications WaveTool](#) application, navigate to the **Start menu > Analog Devices > ApplicationsWaveTool** and click [ApplicationsWaveTool](#).

INSTRUCTIONS TO LOAD THE FIRMWARE

It is possible that the [EVAL-ADPDCUZ](#) microcontroller board is loaded with an older version of the firmware at the time that it was stocked. In this scenario, the user receives the message shown in Figure 5 when attempting to connect to the WaveTool.

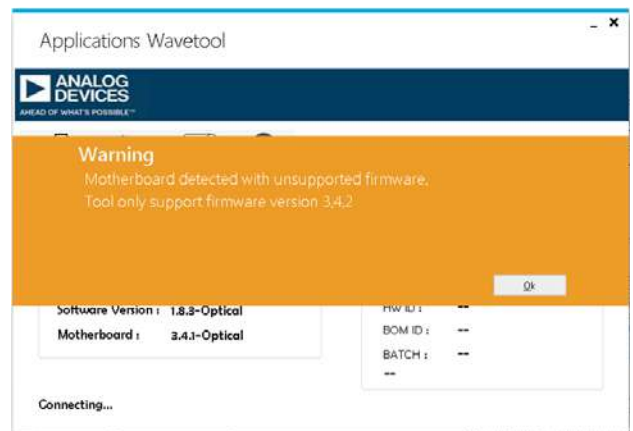

Figure 5. Warning Message for Outdated Firmware

If the firmware must be updated, take the following steps:

1. Download and install the latest DfuSe USB device firmware upgrade software.
2. Plug in a micro USB cable between the EVAL-ADPDUCZ and the PC with the power to the EVAL-ADPDUCZ turned off (see Figure 6).
3. Press and hold the **BOOT0** button, and switch the power switch to the **ON** position

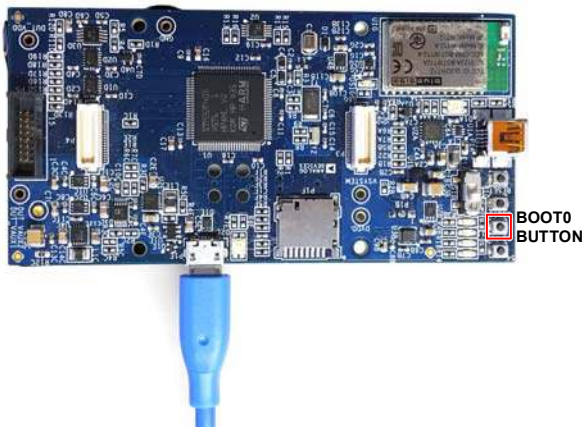

Figure 6. Micro USB Connection and **BOOT0** Button Used when Upgrading Firmware

4. Go to **Device Manager** > **Universal Serial Bus controllers** and wait until the PC detects **STM Device in DFU Mode** (see Figure 7). If the PC does not detect the STM device in DFU mode, then the STM drivers must be manually installed to continue updating the firmware.



Figure 7. **STM Device in DFU Mode** Displayed

5. Release the **BOOT0** button.
6. Open the **DfuSe Demo** by going to **Start** > **All Programs** > **STMicroelectronics** > **DfuSe** > **DfuSe Demo**. Figure 8 shows the **DfuSe** demo settings at startup.
7. Click the **Choose** button from the **Upgrade or Verify Action** window and select **Adpd_M4_uC.dfu** from the **Firmware** folder of the downloaded software package.

8. Click the **Upgrade** button and follow the prompts to upgrade the firmware of the **EVAL-ADPDUCZ** microcontroller board.

After the firmware updates, connection to the WaveTool completes.

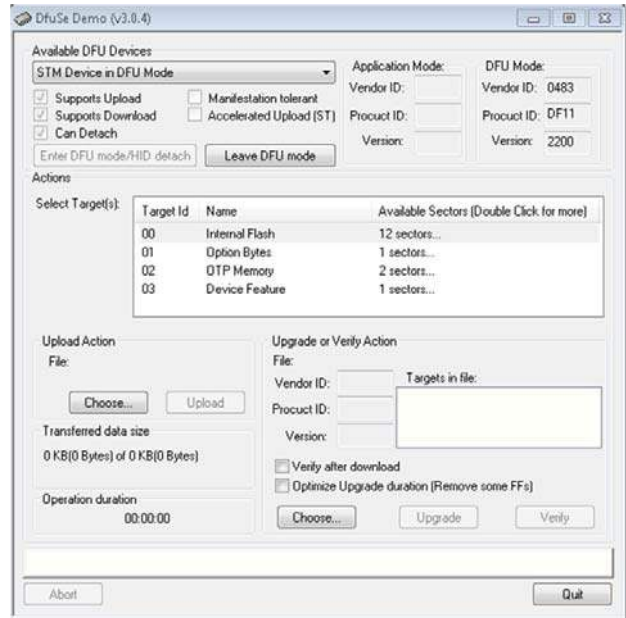

Figure 8. **DfuSe** Demo Settings

USB UART CONNECTION

To establish the USB UART connection, use the following menu path: **Connection** > **Connect** > **UART Bridge**.

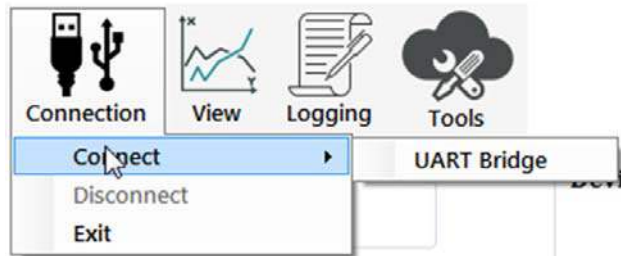

Figure 9. **UART** Connection

Select the proper COM port to connect the WaveTool to the device. If connection via Bluetooth is required, or if there are any other connection issues, refer to the [Applications WaveTool](#) user guide that is provided in the software package download.

ACQUIRING DATA

SELECTING THE PROPER VIEW

The EVAL-ADPD188BIZ-SK is intended for smoke and aerosol detection applications. Select the **Smoke Device** data view (see Figure 10) to open a window that allows the user to run the **ADPD188BI** device and to collect data (see Figure 19).

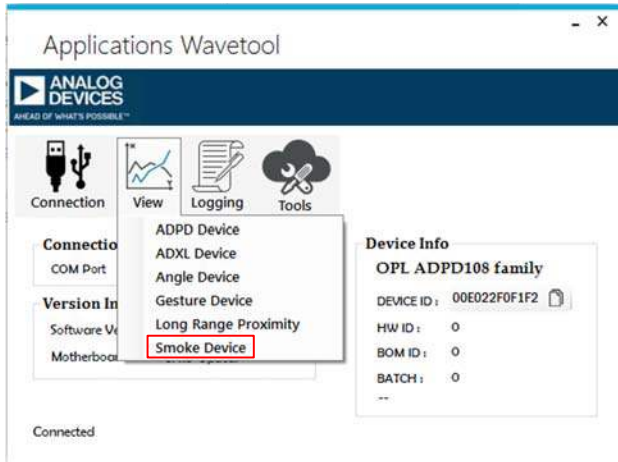

Figure 10. Selecting the **Smoke Device** Data View

LOAD CONFIGURATION

In the upper right corner of the data view window, click the **ADPD Config** button (see Figure 11) to open the **Configuration** window.

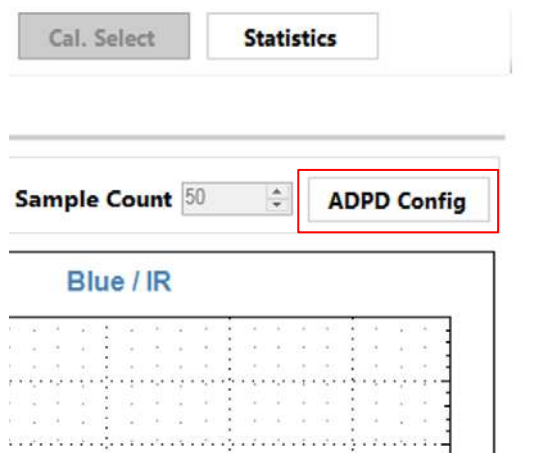

Figure 11. Selecting **ADPD Config** to Open the **Configuration** Window

In the **Configuration** window, click **Load DCFG** to select a configuration file, as shown in Figure 12. For smoke and aerosol measurements, select the **ADPD188BI_SK.dcfg** configuration file from the file dialog box.



Figure 12. Selecting **Load DCFG** to Select the Configuration File

OPTIMIZING AND RUNNING THE ADPD188BI

Using the **ADPD188BI_SK.dcfg** configuration file, the **ADPD188BI** is set up with an infrared (IR) LED firing in Time Slot A and the blue LED firing in Time Slot B. The initial configuration is as shown in Figure 18. Before running the **Applications WaveTool**, a few steps must be taken to optimize the data collection view and provide valid blue/IR ratios.

1. In the data view (see Figure 19), click the **Op Select** button to open the view shown in Figure 13. Select **SB_Sum**, **SA_Sum**, and the / operation, as shown in Figure 13, to configure the blue/IR ratio in the data view.

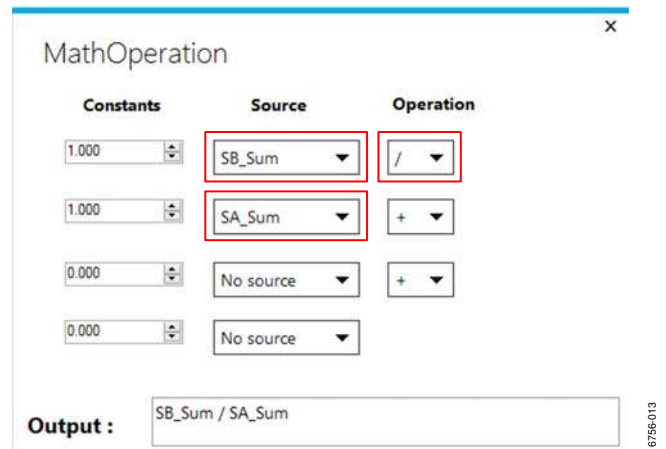

Figure 13. **Op Select** View

2. Before running the WaveTool, make sure the operating mode shown in the **Set SlotMode** window of the data view is set to **ADPDDrv_SUM_32** for both Time Slot A and Time Slot B, as shown in Figure 14.

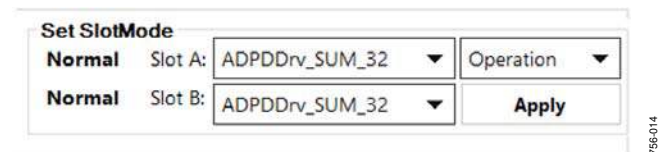

Figure 14. Selecting **ADPDDrv_SUM_32**

- With the sensor board in a fixed position and no aerosol or smoke in the optical path, run the WaveTool by pressing the play button. The raw data view, **Slot A/B vs Time**, must be at some average level. This average level must be nulled out before measuring smoke or aerosol, as described in the following steps (Step 4 to Step 6).

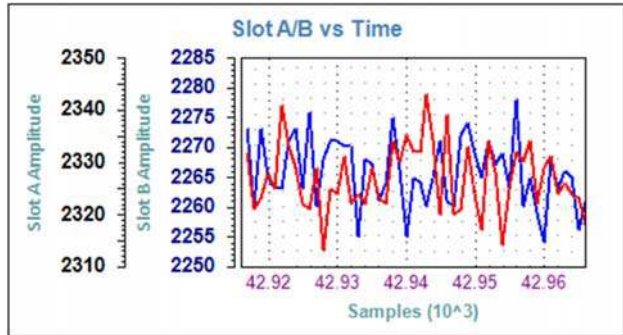

Figure 15. Average Value Prior to Nulling Offset

- Open the **Statistics** window by clicking the **Statistics** button in the data view.
- In the **Statistics** window, select **Continuous Update**. Allow the **Statistics** window to calculate the mean value. After a mean value is calculated, click the **Subtract mean from Offsets** button.

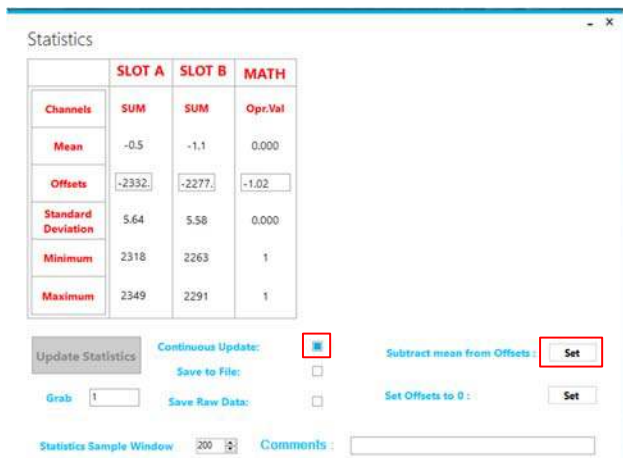

Figure 16. Statistics Window

- In the data view, click the **Null Offset** button to set the Time Slot A and Time Slot B raw data values to approximately zero, plus or minus the noise that may be present (see Figure 17).

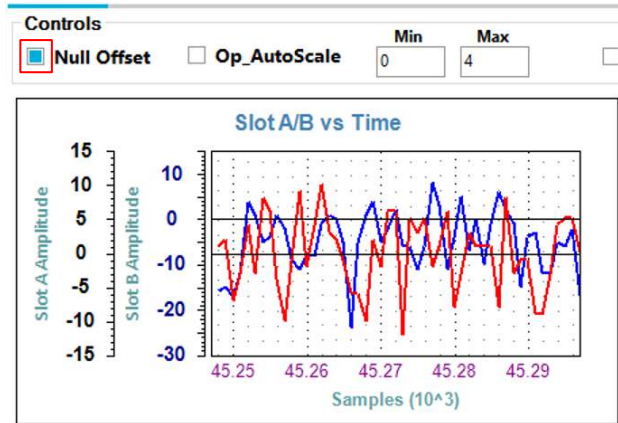

Figure 17. Data View Following Null Offset

After these steps are complete, the user can begin testing with different aerosols. Figure 19 shows the raw output data, as well as the blue/IR ratio of the response to a jet of smoke spray. The **EN_MW** button can be pressed to enable an eight point moving average filter on the data being plotted.

The settings can be further optimized by manipulating the LED drive currents, the transimpedance amplifier (TIA) gain, the number of pulses, and the decimation rate until the desired signal-to-noise ratio (SNR) is obtained from the response to the smoke or aerosol being detected. For information about optimizing the **ADPD188BI**, refer to the **ADPD188BI** data sheet. For functional descriptions of the **Applications WaveTool**, refer to the **Applications WaveTool** user guide provided in the software package download.

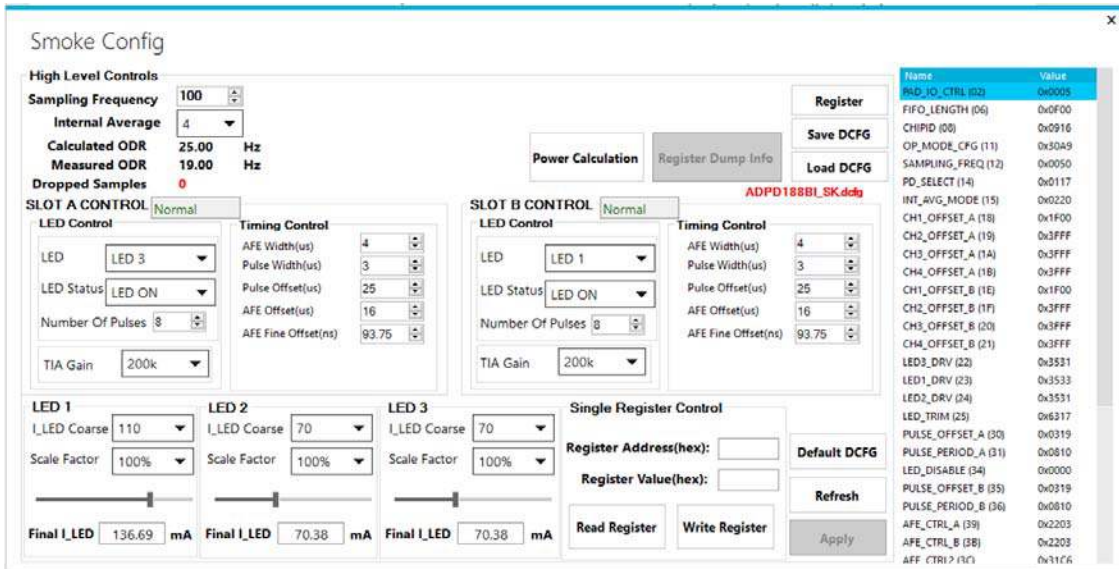

Figure 18. Smoke Device Configuration (Smoke Config) View



Figure 19. Raw Data Response and Blue/IR Ratio Measurement of Smoke Spray

EVALUATION BOARD SCHEMATICS AND ARTWORK

02095291

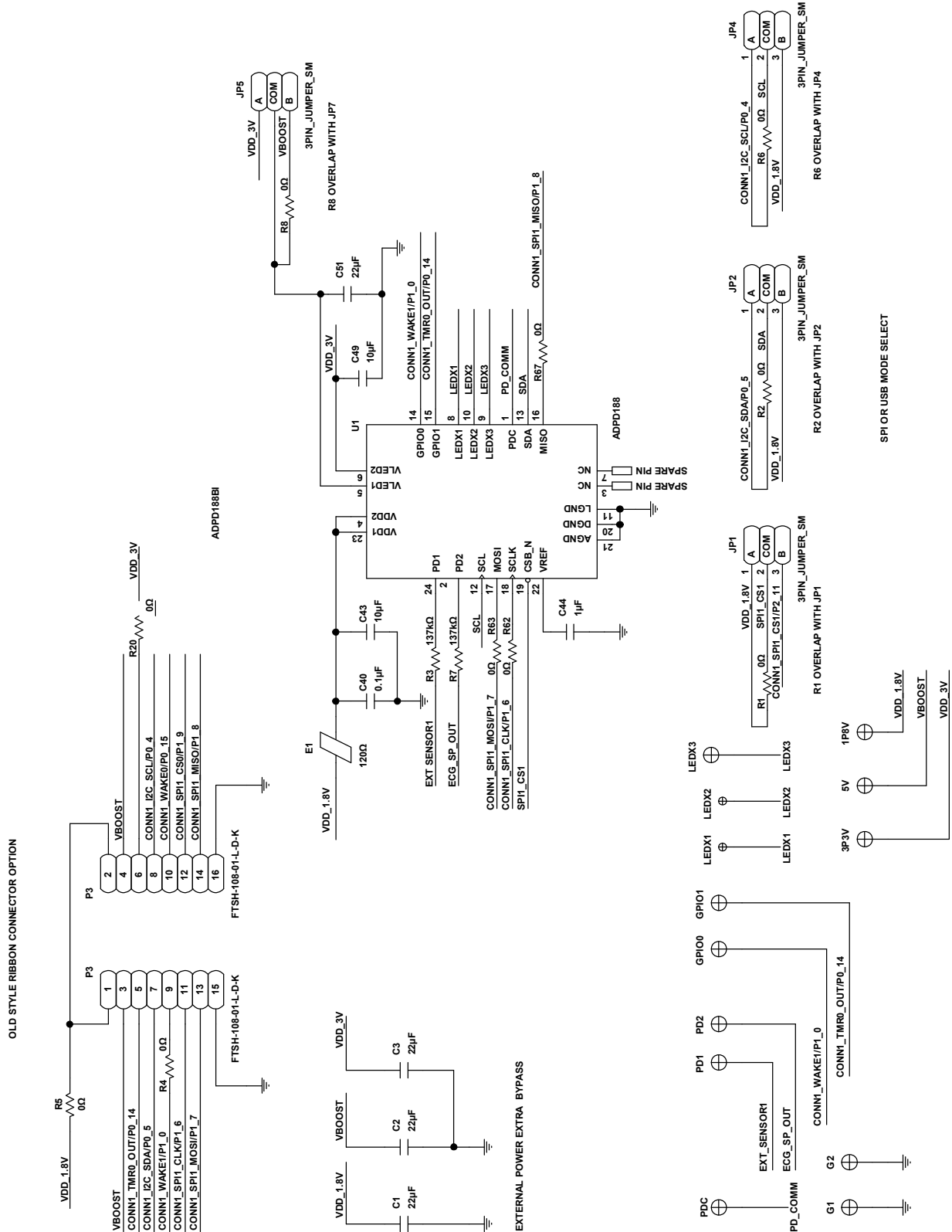

Figure 20. EVAL-ADPD188BIZ-SK Schematic, Page 1

16756-021

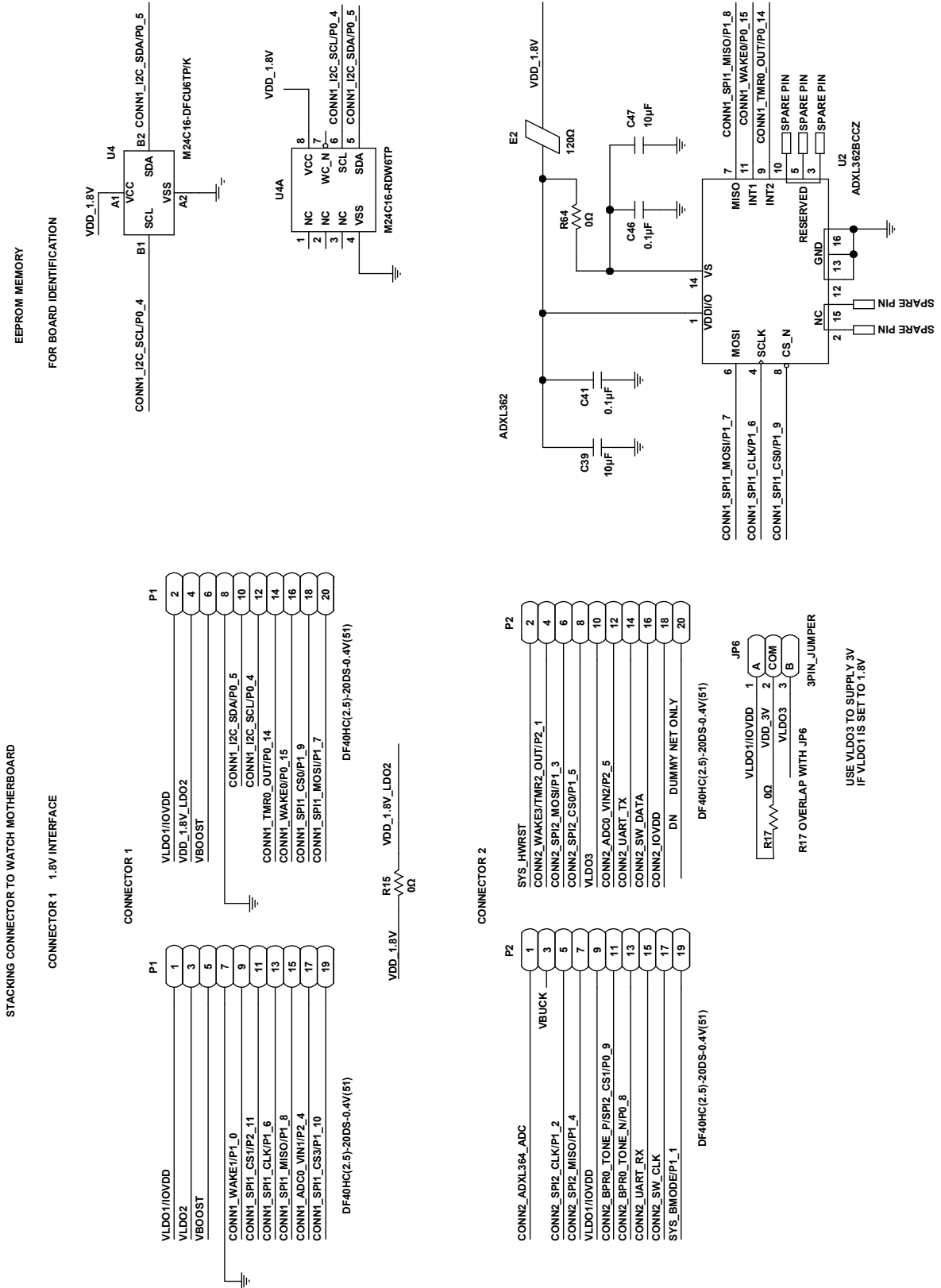

Figure 21. EVAL-ADPD188BIZ-SK Schematic, Page 2

NOTES

**ESD Caution**

ESD (electrostatic discharge) sensitive device. Charged devices and circuit boards can discharge without detection. Although this product features patented or proprietary protection circuitry, damage may occur on devices subjected to high energy ESD. Therefore, proper ESD precautions should be taken to avoid performance degradation or loss of functionality.

Legal Terms and Conditions

By using the evaluation board discussed herein (together with any tools, components documentation or support materials, the "Evaluation Board"), you are agreeing to be bound by the terms and conditions set forth below ("Agreement") unless you have purchased the Evaluation Board, in which case the Analog Devices Standard Terms and Conditions of Sale shall govern. Do not use the Evaluation Board until you have read and agreed to the Agreement. Your use of the Evaluation Board shall signify your acceptance of the Agreement. This Agreement is made by and between you ("Customer") and Analog Devices, Inc. ("ADI"), with its principal place of business at One Technology Way, Norwood, MA 02062, USA. Subject to the terms and conditions of the Agreement, ADI hereby grants to Customer a free, limited, personal, temporary, non-exclusive, non-sublicensable, non-transferable license to use the Evaluation Board FOR EVALUATION PURPOSES ONLY. Customer understands and agrees that the Evaluation Board is provided for the sole and exclusive purpose referenced above, and agrees not to use the Evaluation Board for any other purpose. Furthermore, the license granted is expressly made subject to the following additional limitations: Customer shall not (i) rent, lease, display, sell, transfer, assign, sublicense, or distribute the Evaluation Board; and (ii) permit any Third Party to access the Evaluation Board. As used herein, the term "Third Party" includes any entity other than ADI, Customer, their employees, affiliates and in-house consultants. The Evaluation Board is NOT sold to Customer; all rights not expressly granted herein, including ownership of the Evaluation Board, are reserved by ADI. CONFIDENTIALITY. This Agreement and the Evaluation Board shall all be considered the confidential and proprietary information of ADI. Customer may not disclose or transfer any portion of the Evaluation Board to any other party for any reason. Upon discontinuation of use of the Evaluation Board or termination of this Agreement, Customer agrees to promptly return the Evaluation Board to ADI. ADDITIONAL RESTRICTIONS. Customer may not disassemble, decompile or reverse engineer chips on the Evaluation Board. Customer shall inform ADI of any occurred damages or any modifications or alterations it makes to the Evaluation Board, including but not limited to soldering or any other activity that affects the material content of the Evaluation Board. Modifications to the Evaluation Board must comply with applicable law, including but not limited to the RoHS Directive. TERMINATION. ADI may terminate this Agreement at any time upon giving written notice to Customer. Customer agrees to return to ADI the Evaluation Board at that time. LIMITATION OF LIABILITY. THE EVALUATION BOARD PROVIDED HEREUNDER IS PROVIDED "AS IS" AND ADI MAKES NO WARRANTIES OR REPRESENTATIONS OF ANY KIND WITH RESPECT TO IT. ADI SPECIFICALLY DISCLAIMS ANY REPRESENTATIONS, ENDORSEMENTS, GUARANTEES, OR WARRANTIES, EXPRESS OR IMPLIED, RELATED TO THE EVALUATION BOARD INCLUDING, BUT NOT LIMITED TO, THE IMPLIED WARRANTY OF MERCHANTABILITY, TITLE, FITNESS FOR A PARTICULAR PURPOSE OR NON-INFRINGEMENT OF INTELLECTUAL PROPERTY RIGHTS. IN NO EVENT WILL ADI AND ITS LICENSORS BE LIABLE FOR ANY INCIDENTAL, SPECIAL, INDIRECT, OR CONSEQUENTIAL DAMAGES RESULTING FROM CUSTOMER'S POSSESSION OR USE OF THE EVALUATION BOARD, INCLUDING BUT NOT LIMITED TO LOST PROFITS, DELAY COSTS, LABOR COSTS OR LOSS OF GOODWILL. ADI'S TOTAL LIABILITY FROM ANY AND ALL CAUSES SHALL BE LIMITED TO THE AMOUNT OF ONE HUNDRED US DOLLARS (\$100.00). EXPORT. Customer agrees that it will not directly or indirectly export the Evaluation Board to another country, and that it will comply with all applicable United States federal laws and regulations relating to exports. GOVERNING LAW. This Agreement shall be governed by and construed in accordance with the substantive laws of the Commonwealth of Massachusetts (excluding conflict of law rules). Any legal action regarding this Agreement will be heard in the state or federal courts having jurisdiction in Suffolk County, Massachusetts, and Customer hereby submits to the personal jurisdiction and venue of such courts. The United Nations Convention on Contracts for the International Sale of Goods shall not apply to this Agreement and is expressly disclaimed.