



STB21N90K5, STF21N90K5, STP21N90K5, STW21N90K5

N-channel 900 V, 0.25 Ω typ., 18.5 A Zener-protected SuperMESH™ 5 Power MOSFET in a D²PAK, TO-220FP, TO-220 and TO-247 packages

Datasheet — production data

Features

Order codes	V _{DSS}	R _{DS(on)} max	I _D	P _W
STB21N90K5	900 V	< 0.299 Ω	18.5 A	250 W
STF21N90K5				40 W
STP21N90K5				250 W
STW21N90K5				

- TO-220 worldwide best R_{DS(on)}
- Worldwide best FOM (figure of merit)
- Ultra low gate charge
- 100% avalanche tested
- Zener-protected

Applications

- Switching applications

Description

These devices are N-channel Power MOSFETs developed using SuperMESH™ 5 technology. This revolutionary, avalanche-rugged, high voltage Power MOSFET technology is based on an innovative proprietary vertical structure. The result is a drastic reduction in on-resistance and ultra low gate charge for applications which require superior power density and high efficiency.

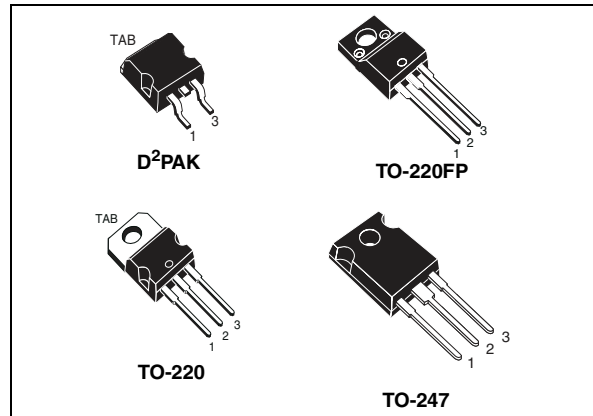
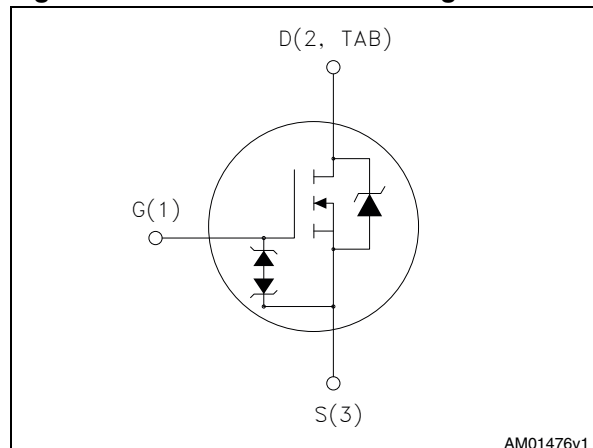

Figure 1. Internal schematic diagram



AM01476v1

Table 1. Device summary

Order codes	Marking	Package	Packaging
STB21N90K5	21N90K5	D ² PAK	Tape and reel
STF21N90K5		TO-220FP	Tube
STP21N90K5		TO-220	
STW21N90K5		TO-247	

Contents

1	Electrical ratings	3
2	Electrical characteristics	4
2.1	Electrical characteristics (curves)	6
3	Test circuits	9
4	Package mechanical data	10
5	Packaging mechanical data	19
6	Revision history	21

1 Electrical ratings

Table 2. Absolute maximum ratings

Symbol	Parameter	Value		Unit
		D ² PAK, TO-220, TO-247	TO-220FP	
V _{GS}	Gate- source voltage	± 30		V
I _D	Drain current (continuous) at T _C = 25 °C	18.5	18.5 ⁽¹⁾	A
I _D	Drain current (continuous) at T _C = 100 °C	11.6	11.6 ⁽¹⁾	A
I _{DM} ⁽²⁾	Drain current (pulsed)	74	74 ⁽¹⁾	A
P _{TOT}	Total dissipation at T _C = 25 °C	250	40	W
I _{AR}	Max current during repetitive or single pulse avalanche (pulse width limited by T _{jmax})	6		A
E _{AS}	Single pulse avalanche energy (starting T _J = 25 °C, I _D =I _{AR} , V _{DD} = 50 V)	200		mJ
V _{iso}	Insulation withstand voltage (RMS) from all three leads to external heat sink (t=1 s; T _C =25 °C)		2500	V
dv/dt ⁽³⁾	Peak diode recovery voltage slope	6		V/ns
T _j T _{stg}	Operating junction temperature Storage temperature	-55 to 150		°C

- Limited by package.
- Pulse width limited by safe operating area.
- I_{SD} ≤ 18.5 A, di/dt ≤ 100 A/μs, V_{DS(peak)} ≤ V_{(BR)DSS}

Table 3. Thermal data

Symbol	Parameter	Value				Unit
		D ² PAK	TO-220FP	TO-220	TO-247	
R _{thj-case}	Thermal resistance junction-case max	0.5	3.13	0.5		°C/W
R _{thj-amb}	Thermal resistance junction-amb max		62.5		50	
R _{thj-pcb}	Thermal resistance junction-pcb max	30				

2 Electrical characteristics

($T_{CASE} = 25\text{ °C}$ unless otherwise specified).

Table 4. On/off states

Symbol	Parameter	Test conditions	Min.	Typ.	Max.	Unit
$V_{(BR)DSS}$	Drain-source breakdown voltage ($V_{GS} = 0$)	$I_D = 1\text{ mA}$	900			V
I_{DSS}	Zero gate voltage drain current ($V_{GS} = 0$)	$V_{DS} = 900\text{ V}$ $V_{DS} = 900\text{ V}, T_c = 125\text{ °C}$			1 50	μA μA
I_{GSS}	Gate body leakage current ($V_{DS} = 0$)	$V_{GS} = \pm 20\text{ V}$			± 10	μA
$V_{GS(th)}$	Gate threshold voltage	$V_{DS} = V_{GS}, I_D = 100\text{ }\mu\text{A}$	3	4	5	V
$R_{DS(on)}$	Static drain-source on resistance	$V_{GS} = 10\text{ V}, I_D = 9\text{ A}$		0.25	0.299	Ω

Table 5. Dynamic

Symbol	Parameter	Test conditions	Min.	Typ.	Max.	Unit
C_{iss}	Input capacitance			1645		pF
C_{oss}	Output capacitance	$V_{DS} = 100\text{ V}, f = 1\text{ MHz}, V_{GS} = 0$	-	112	-	pF
C_{rss}	Reverse transfer capacitance			2		
$C_{o(tr)}^{(1)}$	Equivalent capacitance time related	$V_{GS} = 0, V_{DS} = 0\text{ to }720\text{ V}$	-	133	-	pF
$C_{o(er)}^{(2)}$	Equivalent capacitance energy related			16		
R_G	Intrinsic gate resistance	$f = 1\text{ MHz}$ open drain	-	4	-	Ω
Q_g	Total gate charge	$V_{DD} = 720\text{ V}, I_D = 18.5\text{ A}$ $V_{GS} = 10\text{ V}$ (see Figure 20)	-	43	-	nC
Q_{gs}	Gate-source charge			12		
Q_{gd}	Gate-drain charge			25		

1. Time related is defined as a constant equivalent capacitance giving the same charging time as C_{oss} when V_{DS} increases from 0 to 80% V_{DSS}
2. Energy related is defined as a constant equivalent capacitance giving the same stored energy as C_{oss} when V_{DS} increases from 0 to 80% V_{DSS}

Table 6. Switching times

Symbol	Parameter	Test conditions	Min.	Typ.	Max.	Unit	
$t_{d(on)}$	Turn-on delay time	$V_{DD} = 720 \text{ V}$, $I_D = 10 \text{ A}$, $R_G = 4.7 \text{ } \Omega$, $V_{GS} = 10 \text{ V}$ (see Figure 22)		17		ns	
t_r	Rise time		-	27	-	ns	
$t_{d(off)}$	Turn-off delay time				52		ns
t_f	Fall time				40		ns

Table 7. Source drain diode

Symbol	Parameter	Test conditions	Min.	Typ.	Max.	Unit
I_{SD}	Source-drain current		-		19	A
I_{SDM}	Source-drain current (pulsed)				76	A
$V_{SD}^{(1)}$	Forward on voltage	$I_{SD} = 18.5 \text{ A}$, $V_{GS} = 0$	-		1.5	V
t_{rr}	Reverse recovery time	$I_{SD} = 18.5 \text{ A}$, $V_{DD} = 60 \text{ V}$ $di/dt = 100 \text{ A}/\mu\text{s}$, (see Figure 21)	-	548		ns
Q_{rr}	Reverse recovery charge				12	μC
I_{RRM}	Reverse recovery current				46	A
t_{rr}	Reverse recovery time	$I_{SD} = 18.5 \text{ A}$, $V_{DD} = 60 \text{ V}$ $di/dt = 100 \text{ A}/\mu\text{s}$, $T_J = 150 \text{ }^\circ\text{C}$ (see Figure 21)	-	660		ns
Q_{rr}	Reverse recovery charge				15	μC
I_{RRM}	Reverse recovery current				45	A

1. Pulsed: pulse duration = 300 μs , duty cycle 1.5%

Table 8. Gate-source Zener diode

Symbol	Parameter	Test conditions	Min.	Typ.	Max.	Unit
$V_{(BR)GSO}$	Gate-source breakdown voltage	$I_{GS} = \pm 1 \text{ mA}$, $I_D = 0$	30	-	-	V

The built-in-back Zener diodes have specifically been designed to enhance not only the device's ESD capability, but also to make them safely absorb possible voltage transients that may occasionally be applied from gate to source. In this respect the Zener voltage is appropriate to achieve an efficient and cost-effective intervention to protect the device's integrity. These integrated Zener diodes thus avoid the usage of external components.

2.1 Electrical characteristics (curves)

Figure 2. Safe operating area for TO-220 / D²PAK

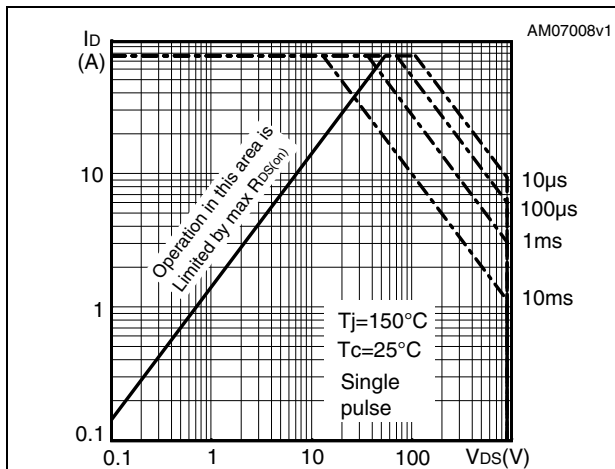

Figure 3. Thermal impedance for TO-220 / D²PAK

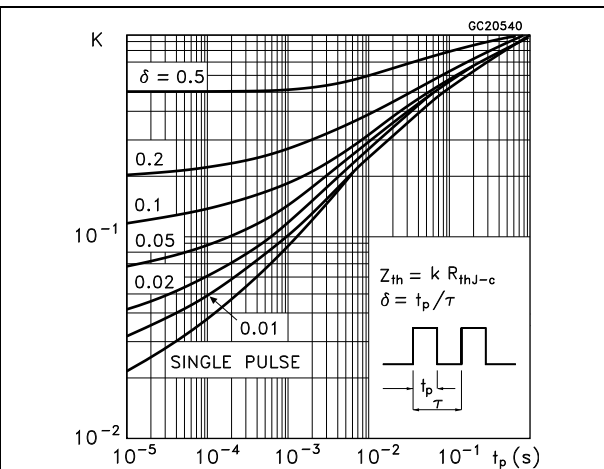

Figure 4. Safe operating area for TO-220FP

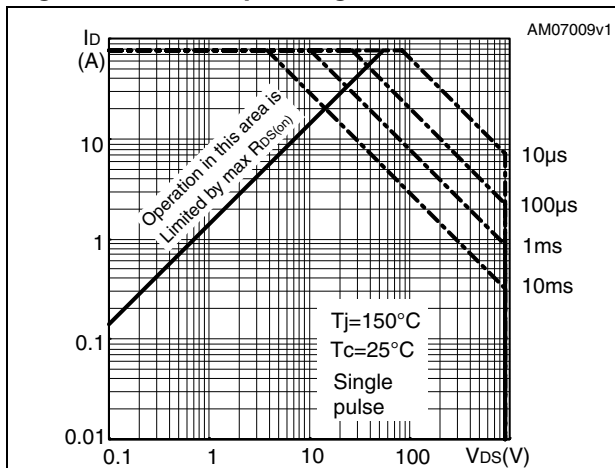

Figure 5. Thermal impedance for TO-220FP

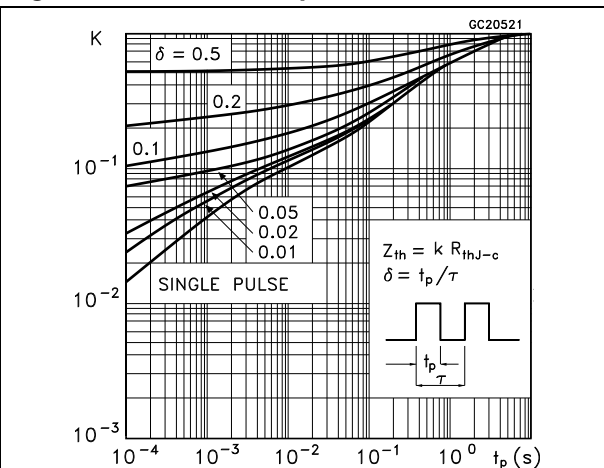

Figure 6. Safe operating area for TO-247

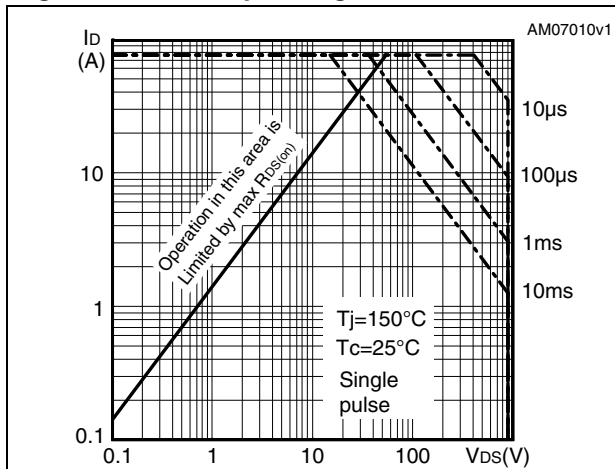

Figure 7. Thermal impedance for TO-247

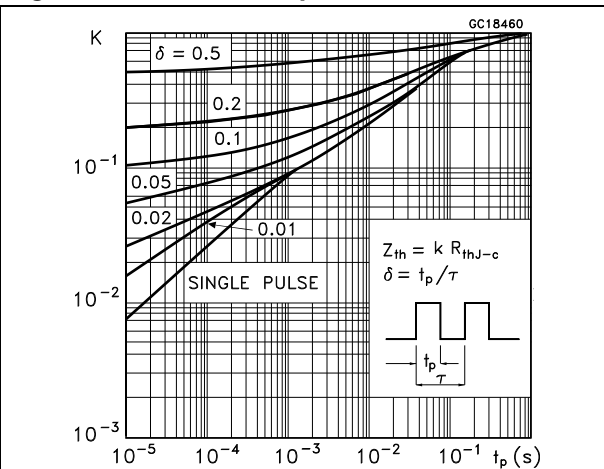

Figure 8. Output characteristics

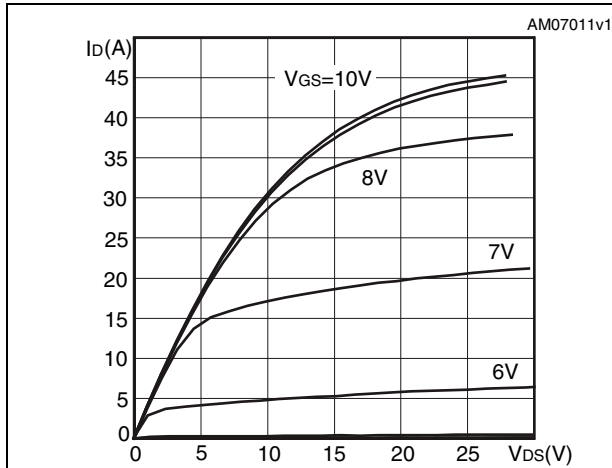

Figure 9. Transfer characteristics

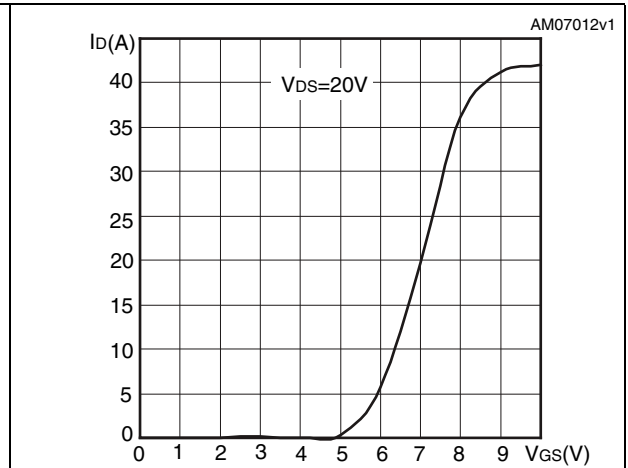

Figure 10. Gate charge vs gate-source voltage Figure 11. Static drain-source on resistance

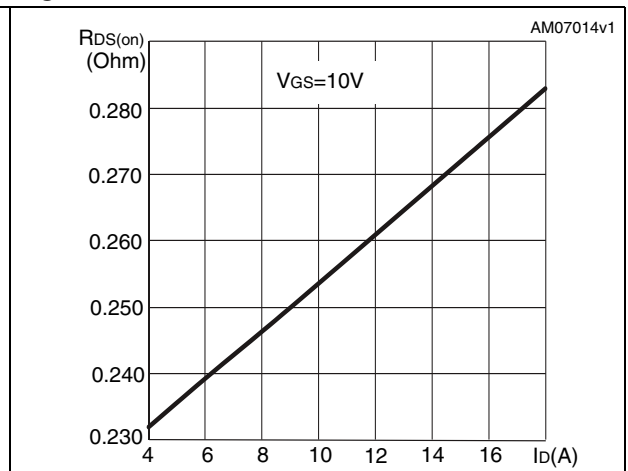
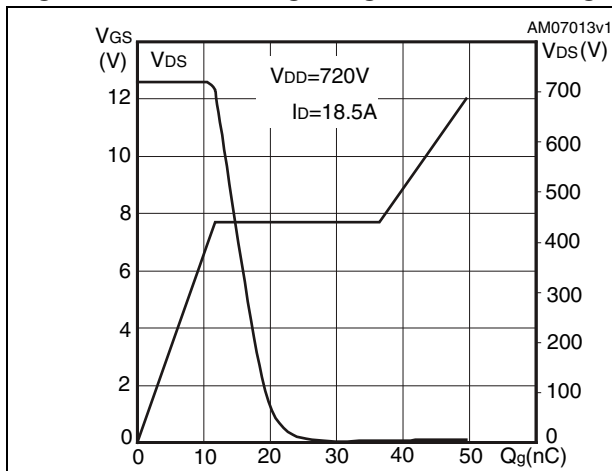

Figure 12. Capacitance variations

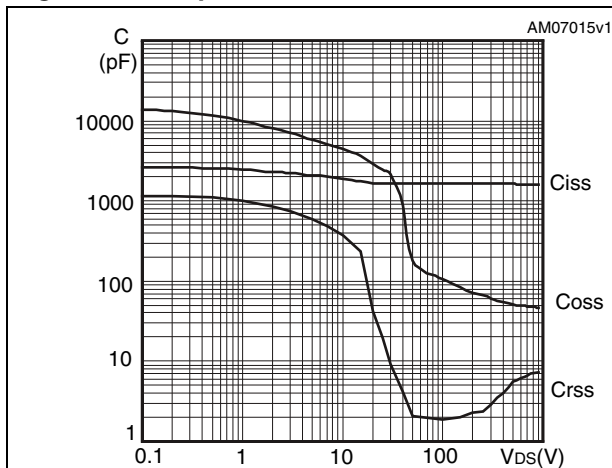

Figure 13. Output capacitance stored energy

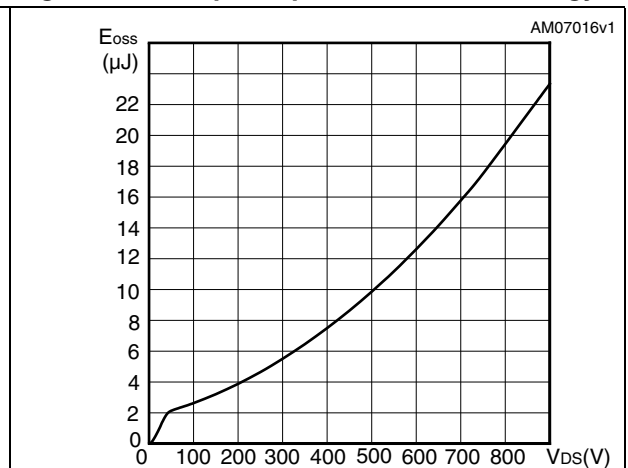

Figure 14. Normalized gate threshold voltage vs temperature



Figure 15. Normalized on-resistance vs temperature

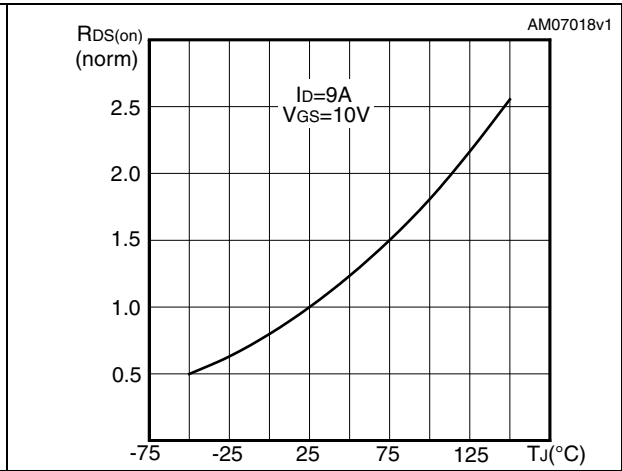

Figure 16. Source-drain diode forward characteristics

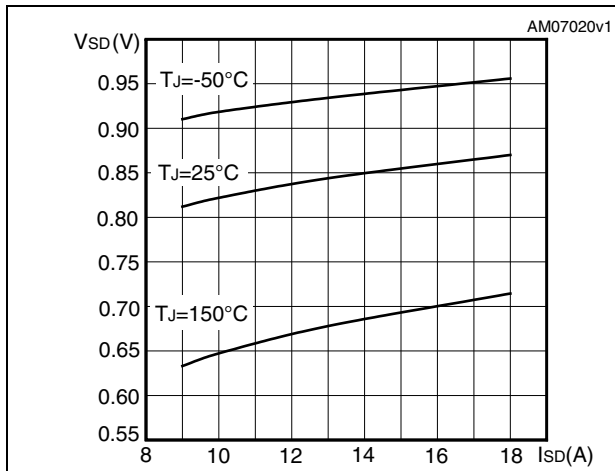

Figure 17. Normalized BV_{DSS} vs temperature

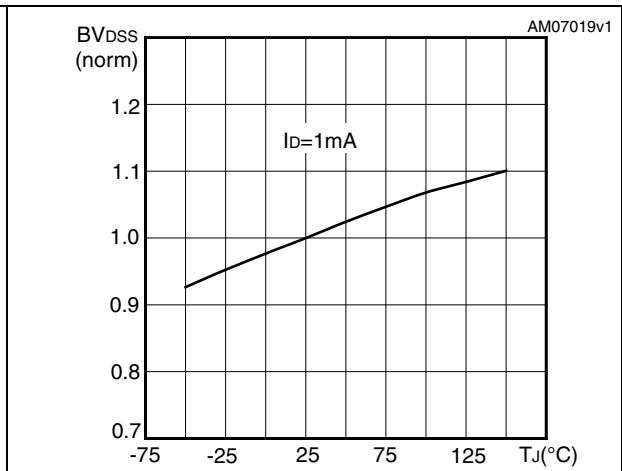
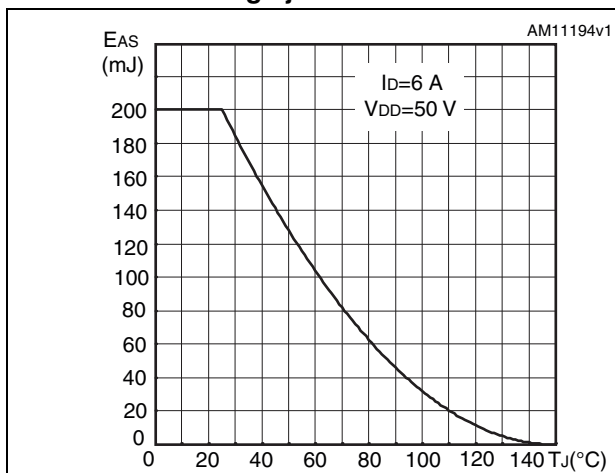

Figure 18. Maximum avalanche energy vs starting T_j



3 Test circuits

Figure 19. Switching times test circuit for resistive load

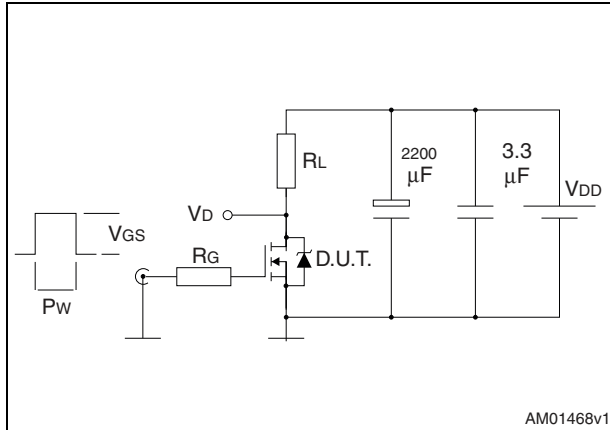

Figure 20. Gate charge test circuit

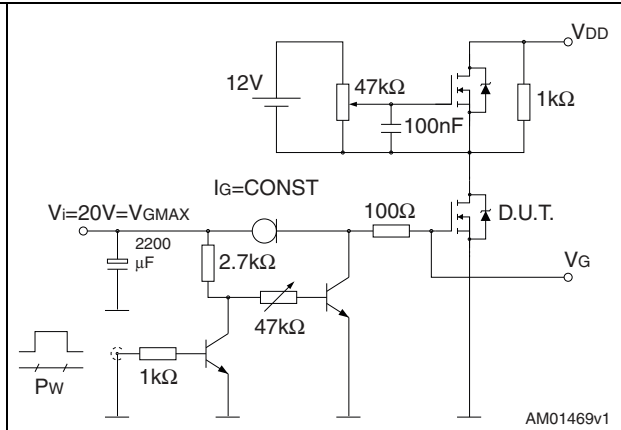

Figure 21. Test circuit for inductive load switching and diode recovery times

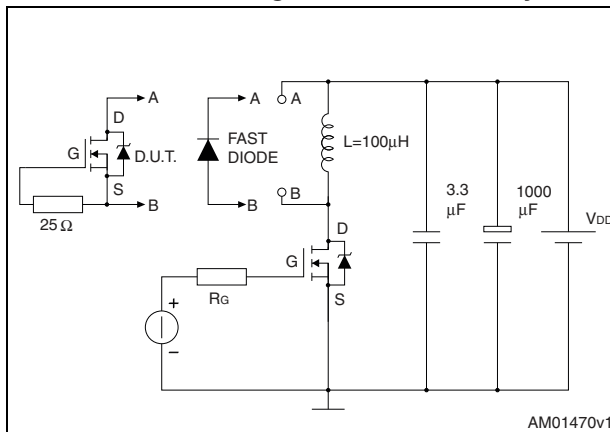

Figure 22. Unclamped inductive load test circuit

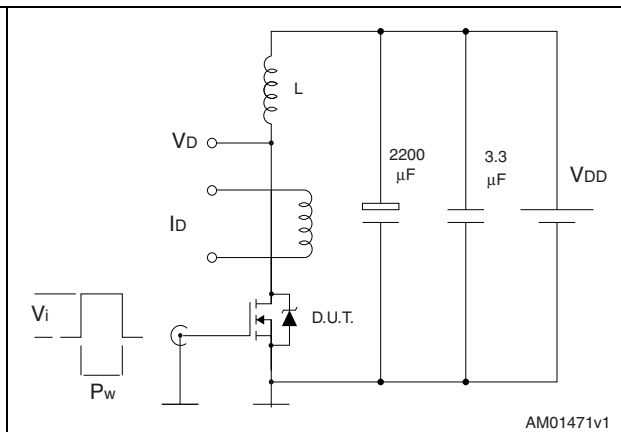

Figure 23. Unclamped inductive waveform

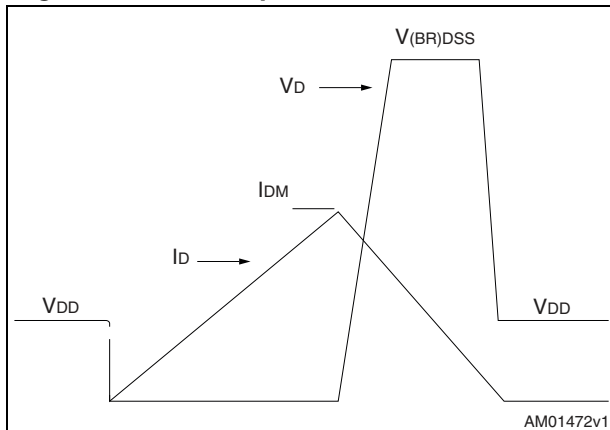
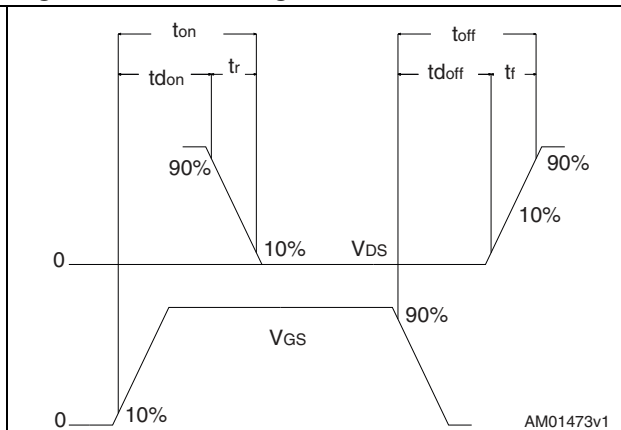

Figure 24. Switching time waveform



4 Package mechanical data

In order to meet environmental requirements, ST offers these devices in different grades of ECOPACK[®] packages, depending on their level of environmental compliance. ECOPACK[®] specifications, grade definitions and product status are available at: www.st.com. ECOPACK[®] is an ST trademark.

Table 9. D²PAK (TO-263) mechanical data

Dim.	mm		
	Min.	Typ.	Max.
A	4.40		4.60
A1	0.03		0.23
b	0.70		0.93
b2	1.14		1.70
c	0.45		0.60
c2	1.23		1.36
D	8.95		9.35
D1	7.50		
E	10		10.40
E1	8.50		
e		2.54	
e1	4.88		5.28
H	15		15.85
J1	2.49		2.69
L	2.29		2.79
L1	1.27		1.40
L2	1.30		1.75
R		0.4	
V2	0°		8°

Figure 25. D²PAK (TO-263) drawing

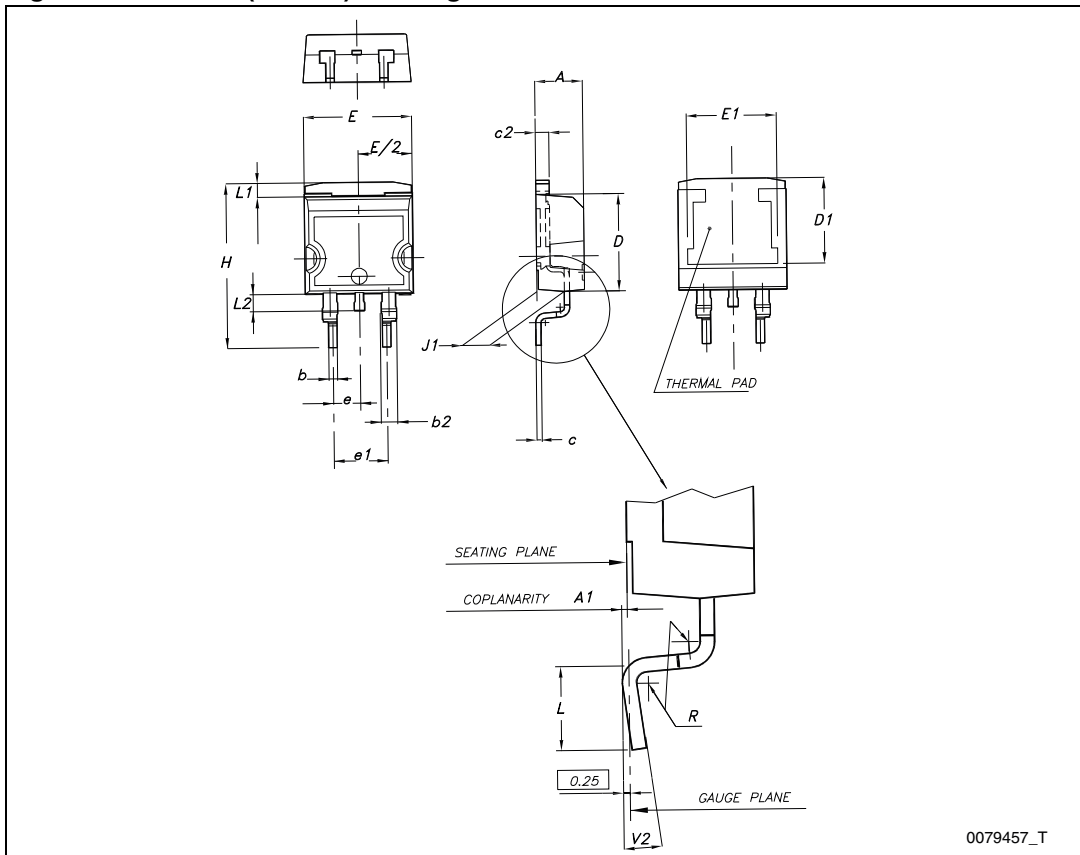
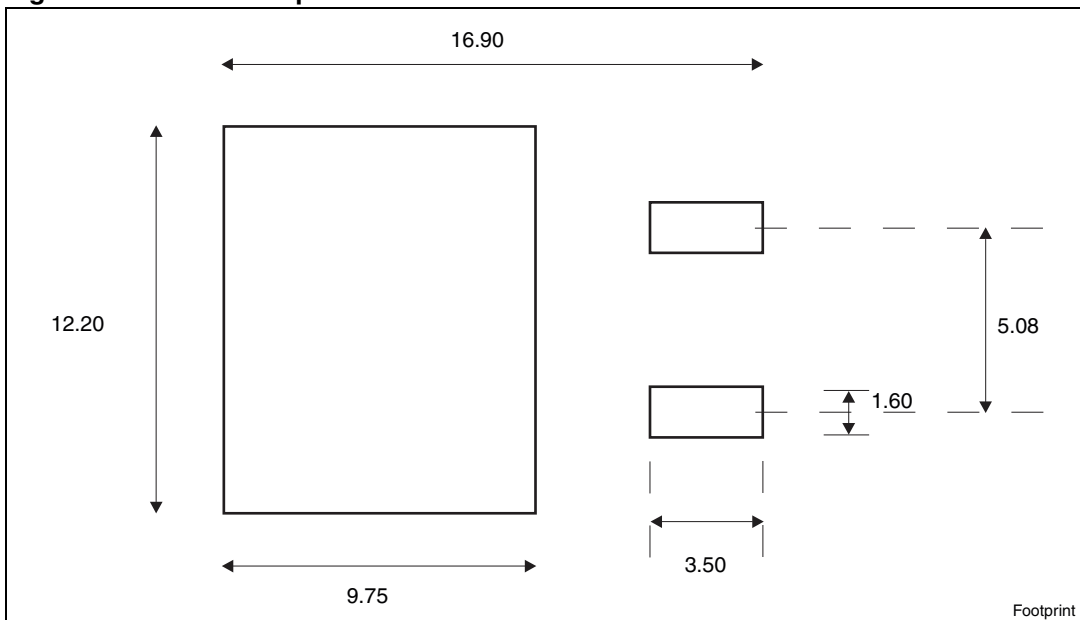

Figure 26. D²PAK footprint^(a)



a. All dimensions are in millimeters

Table 10. TO-220FP mechanical data

Dim.	mm		
	Min.	Typ.	Max.
A	4.4		4.6
B	2.5		2.7
D	2.5		2.75
E	0.45		0.7
F	0.75		1
F1	1.15		1.70
F2	1.15		1.70
G	4.95		5.2
G1	2.4		2.7
H	10		10.4
L2		16	
L3	28.6		30.6
L4	9.8		10.6
L5	2.9		3.6
L6	15.9		16.4
L7	9		9.3
Dia	3		3.2

Figure 27. TO-220FP drawing

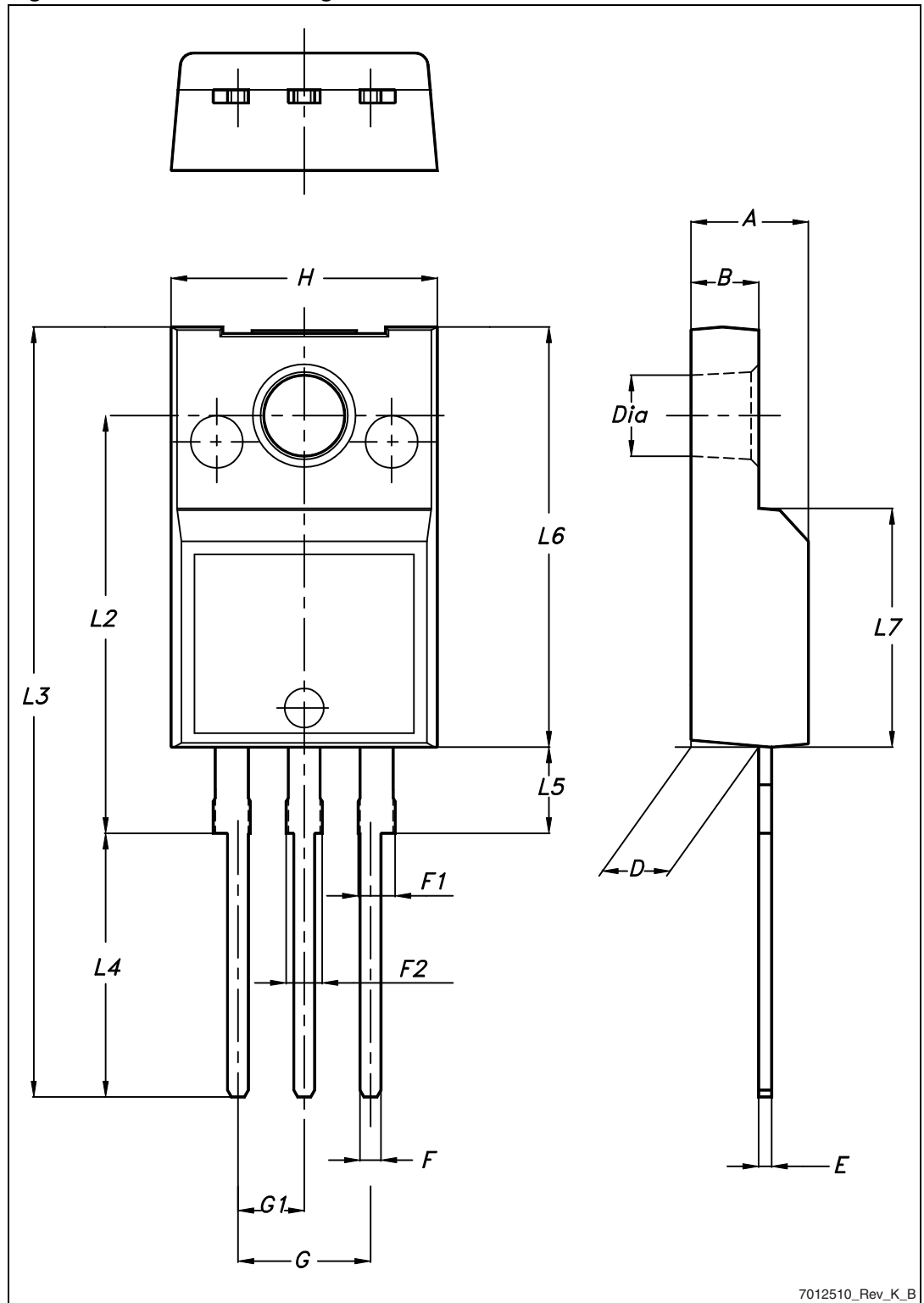

7012510_Rev_K_B

Table 11. TO-220 type A mechanical data

Dim.	mm		
	Min.	Typ.	Max.
A	4.40		4.60
b	0.61		0.88
b1	1.14		1.70
c	0.48		0.70
D	15.25		15.75
D1		1.27	
E	10		10.40
e	2.40		2.70
e1	4.95		5.15
F	1.23		1.32
H1	6.20		6.60
J1	2.40		2.72
L	13		14
L1	3.50		3.93
L20		16.40	
L30		28.90	
ØP	3.75		3.85
Q	2.65		2.95

Figure 28. TO-220 type A drawing

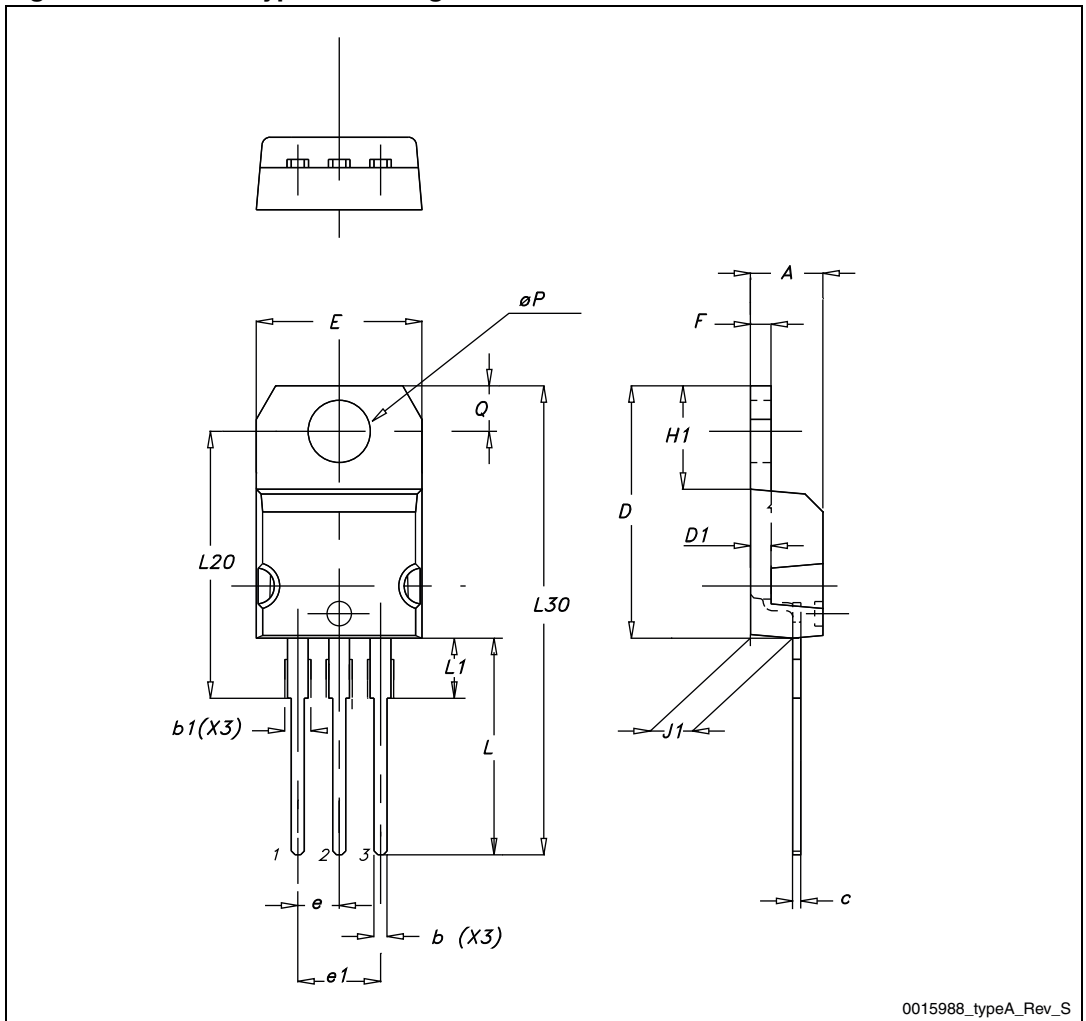

0015988_typeA_Rev_S

Table 12. TO-247 mechanical data

Dim.	mm.		
	Min.	Typ.	Max.
A	4.85		5.15
A1	2.20		2.60
b	1.0		1.40
b1	2.0		2.40
b2	3.0		3.40
c	0.40		0.80
D	19.85		20.15
E	15.45		15.75
e	5.30	5.45	5.60
L	14.20		14.80
L1	3.70		4.30
L2		18.50	
ØP	3.55		3.65
ØR	4.50		5.50
S	5.30	5.50	5.70

Figure 29. TO-247 drawing

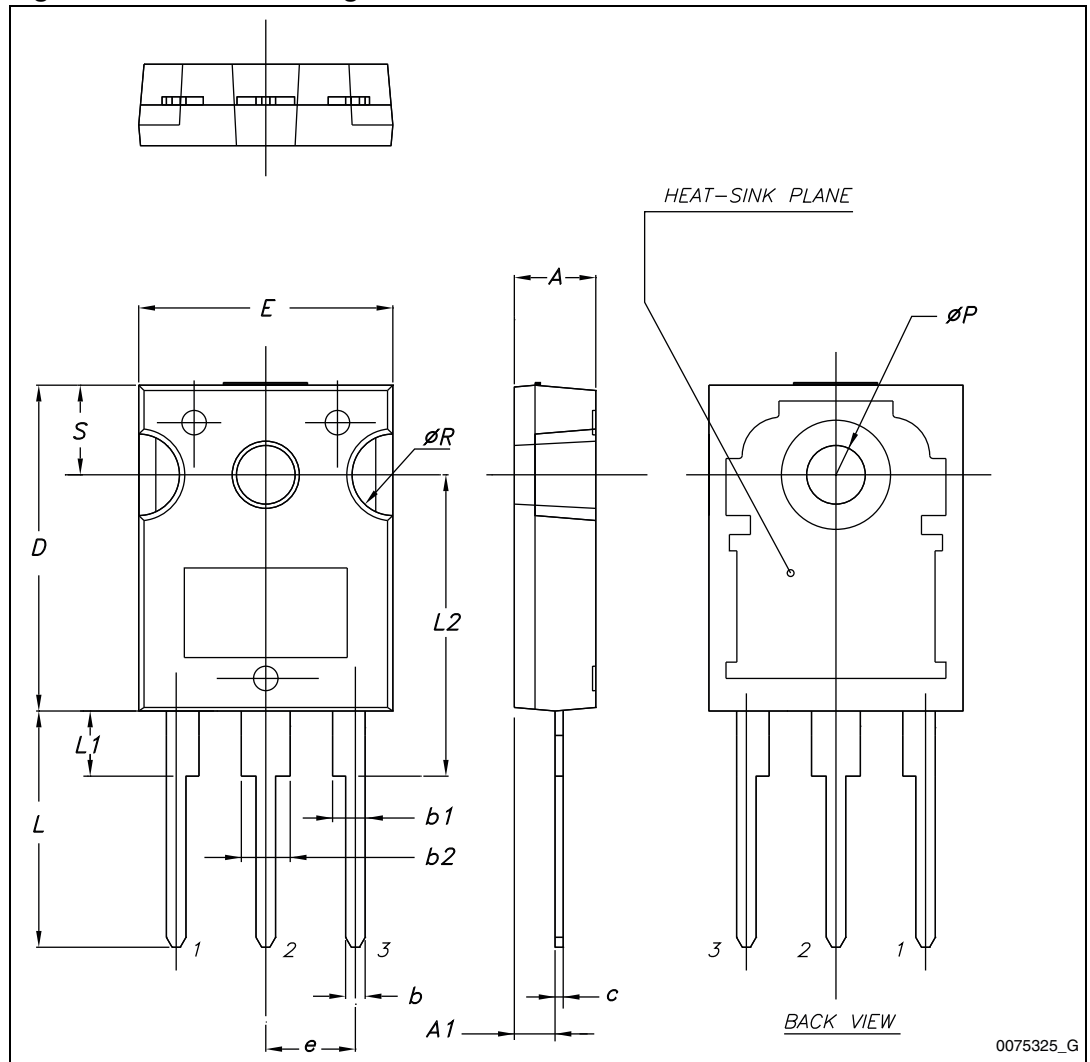

5 Packaging mechanical data

Table 13. D²PAK (TO-263) tape and reel mechanical data

Tape			Reel		
Dim.	mm		Dim.	mm	
	Min.	Max.		Min.	Max.
A0	10.5	10.7	A		330
B0	15.7	15.9	B	1.5	
D	1.5	1.6	C	12.8	13.2
D1	1.59	1.61	D	20.2	
E	1.65	1.85	G	24.4	26.4
F	11.4	11.6	N	100	
K0	4.8	5.0	T		30.4
P0	3.9	4.1			
P1	11.9	12.1		Base qty	1000
P2	1.9	2.1		Bulk qty	1000
R	50				
T	0.25	0.35			
W	23.7	24.3			

Figure 30. Tape for D²PAK (TO-263) and DPAK (TO-252)

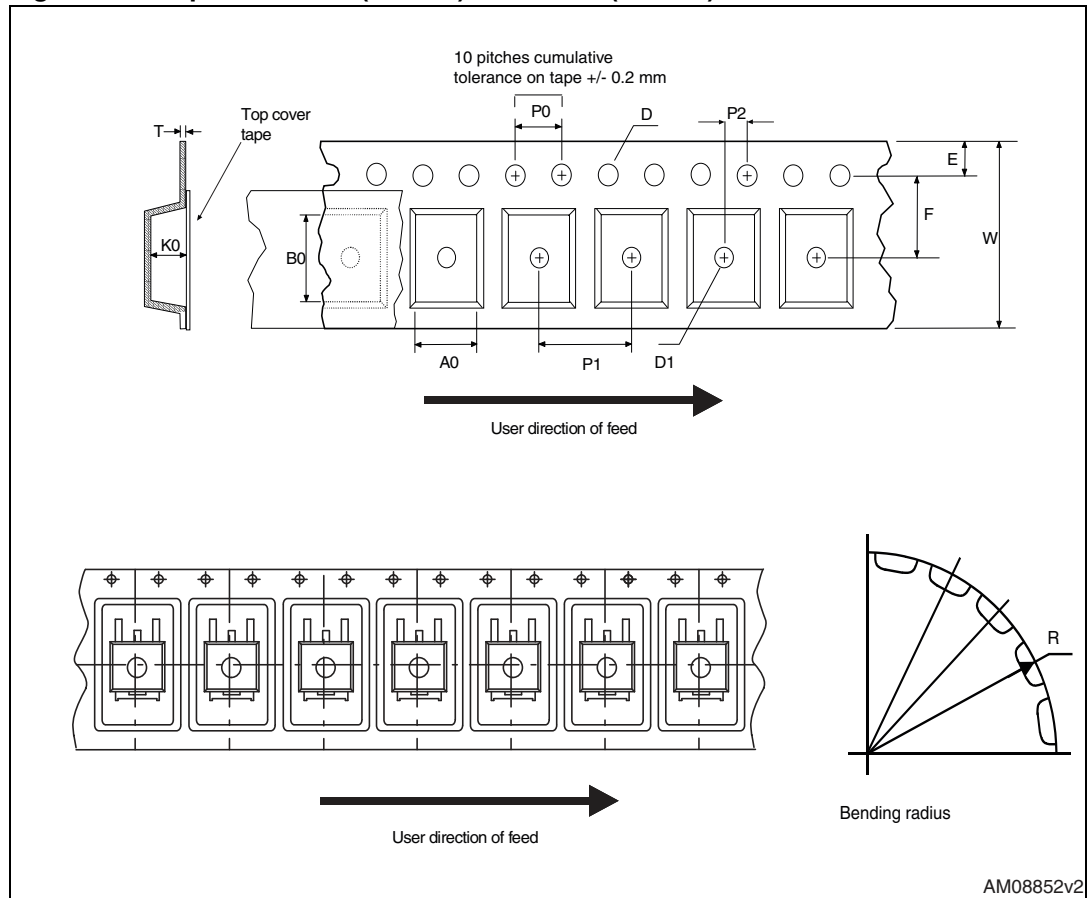
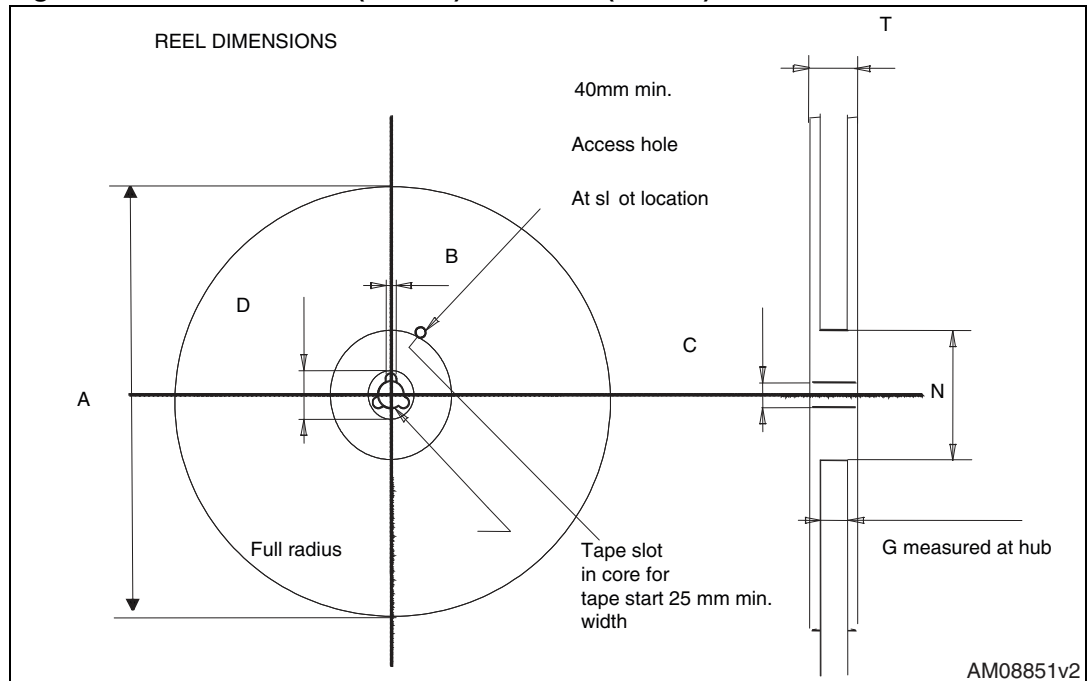

Figure 31. Reel for D²PAK (TO-263) and DPAK (TO-252)



6 Revision history

Table 14. Document revision history

Date	Revision	Changes
05-Nov-2009	1	First release.
18-Nov-2009	2	Updated description on cover page
12-Jan-2010	3	Corrected V_{GS} value in Table 2: Absolute maximum ratings
14-Jul-2010	4	Document status promoted from preliminary data to datasheet.
21-Dec-2011	5	<ul style="list-style-type: none"> – Inserted device in D²PAK. – Updated Figure 2: Safe operating area for TO-220 / D2PAK, Figure 4: Safe operating area for TO-220FP and Figure 6: Safe operating area for TO-247. – Inserted Section 5: Packaging mechanical data on page 19. – Minor text changes.
12-Oct-2012	6	<ul style="list-style-type: none"> – Updated: Q_g value (test conditions) in Table 5 – Updated: $T_{d(on)}$ value (test conditions) in Table 6 – Updated: values (test conditions) in Table 8 – Updated: Figure 10 – Updated: Section 4: Package mechanical data

Please Read Carefully:

Information in this document is provided solely in connection with ST products. STMicroelectronics NV and its subsidiaries ("ST") reserve the right to make changes, corrections, modifications or improvements, to this document, and the products and services described herein at any time, without notice.

All ST products are sold pursuant to ST's terms and conditions of sale.

Purchasers are solely responsible for the choice, selection and use of the ST products and services described herein, and ST assumes no liability whatsoever relating to the choice, selection or use of the ST products and services described herein.

No license, express or implied, by estoppel or otherwise, to any intellectual property rights is granted under this document. If any part of this document refers to any third party products or services it shall not be deemed a license grant by ST for the use of such third party products or services, or any intellectual property contained therein or considered as a warranty covering the use in any manner whatsoever of such third party products or services or any intellectual property contained therein.

UNLESS OTHERWISE SET FORTH IN ST'S TERMS AND CONDITIONS OF SALE ST DISCLAIMS ANY EXPRESS OR IMPLIED WARRANTY WITH RESPECT TO THE USE AND/OR SALE OF ST PRODUCTS INCLUDING WITHOUT LIMITATION IMPLIED WARRANTIES OF MERCHANTABILITY, FITNESS FOR A PARTICULAR PURPOSE (AND THEIR EQUIVALENTS UNDER THE LAWS OF ANY JURISDICTION), OR INFRINGEMENT OF ANY PATENT, COPYRIGHT OR OTHER INTELLECTUAL PROPERTY RIGHT.

UNLESS EXPRESSLY APPROVED IN WRITING BY TWO AUTHORIZED ST REPRESENTATIVES, ST PRODUCTS ARE NOT RECOMMENDED, AUTHORIZED OR WARRANTED FOR USE IN MILITARY, AIR CRAFT, SPACE, LIFE SAVING, OR LIFE SUSTAINING APPLICATIONS, NOR IN PRODUCTS OR SYSTEMS WHERE FAILURE OR MALFUNCTION MAY RESULT IN PERSONAL INJURY, DEATH, OR SEVERE PROPERTY OR ENVIRONMENTAL DAMAGE. ST PRODUCTS WHICH ARE NOT SPECIFIED AS "AUTOMOTIVE GRADE" MAY ONLY BE USED IN AUTOMOTIVE APPLICATIONS AT USER'S OWN RISK.

Resale of ST products with provisions different from the statements and/or technical features set forth in this document shall immediately void any warranty granted by ST for the ST product or service described herein and shall not create or extend in any manner whatsoever, any liability of ST.

ST and the ST logo are trademarks or registered trademarks of ST in various countries.

Information in this document supersedes and replaces all information previously supplied.

The ST logo is a registered trademark of STMicroelectronics. All other names are the property of their respective owners.

© 2012 STMicroelectronics - All rights reserved

STMicroelectronics group of companies

Australia - Belgium - Brazil - Canada - China - Czech Republic - Finland - France - Germany - Hong Kong - India - Israel - Italy - Japan - Malaysia - Malta - Morocco - Philippines - Singapore - Spain - Sweden - Switzerland - United Kingdom - United States of America

www.st.com