

ISOFACE™

ISO11813T

Isolated 8 Channel Digital Input with IEC61131-2 Type 1/2/3 Characteristics

Data Sheet

V 2.2, 2017-01-03

Power Management & Multimarket

Edition 2017-01-03

**Published by
Infineon Technologies AG
81726 Munich, Germany**

**© 2017 Infineon Technologies AG
All Rights Reserved.**

Legal Disclaimer

The information given in this document shall in no event be regarded as a guarantee of conditions or characteristics. With respect to any examples or hints given herein, any typical values stated herein and/or any information regarding the application of the device, Infineon Technologies hereby disclaims any and all warranties and liabilities of any kind, including without limitation, warranties of non-infringement of intellectual property rights of any third party.

Information

For further information on technology, delivery terms and conditions and prices, please contact the nearest Infineon Technologies Office (www.infineon.com).

Warnings

Due to technical requirements, components may contain dangerous substances. For information on the types in question, please contact the nearest Infineon Technologies Office.

Infineon Technologies components may be used in life-support devices or systems only with the express written approval of Infineon Technologies, if a failure of such components can reasonably be expected to cause the failure of that life-support device or system or to affect the safety or effectiveness of that device or system. Life support devices or systems are intended to be implanted in the human body or to support and/or maintain and sustain and/or protect human life. If they fail, it is reasonable to assume that the health of the user or other persons may be endangered.

Revision History: 2017-01-03, V 2.2
Previous Version: Data Sheet V2.1

Page	Subjects (major changes since last revision)
V 2.2	Data Sheet
15	Typo : .. pin $\overline{\text{ERR}}$ to logic high.
V 2.1	Data Sheet
49,56	Typo inside register adress for GLCFG corrected
V 2.0	Data Sheet
7, 10, 12	Description of SEL pin corrected
25	Chapter 3.6 Programmable Digital Input Filter updated and information about filter times added
27	Chapter 3.7 Parallel Interface Mode updated
30	Chapter 3.8.1 SPI Modes write access decription updated
35	Chapter 3.9 SYNC Operation updated
36	Chapter 3.10 Write-Read- Access and Read-Read-Access for Different Applications added
38	Table 3 System Insulation Characteristics Condition for Production test added
46	Table 15 Parallel Interface timing updated
47	Table 16 Serial Interface timing updated

Trademarks of Infineon Technologies AG

AURIX™, C166™, CanPAK™, CIPOS™, CIPURSE™, EconoPACK™, CoolMOS™, CoolSET™, CORECONTROL™, CROSSAVE™, DAVE™, DI-POL™, EasyPIM™, EconoBRIDGE™, EconoDUAL™, EconoPIM™, EconoPACK™, EiceDRIVER™, eupec™, FCOS™, HITFET™, HybridPACK™, I²RF™, ISOFACE™, IsoPACK™, MIPAQ™, ModSTACK™, my-d™, NovalithIC™, OptiMOS™, ORIGA™, POWERCODE™, PRIMARION™, PrimePACK™, PrimeSTACK™, PRO-SIL™, PROFET™, RASIC™, ReverSave™, SatRIC™, SIEGET™, SINDRION™, SIPMOS™, SmartLEWIS™, SOLID FLASH™, TEMPFET™, thinQ!™, TRENCHSTOP™, TriCore™.

Other Trademarks

Advance Design System™ (ADS) of Agilent Technologies, AMBA™, ARM™, MULTI-ICE™, KEIL™, PRIMECELL™, REALVIEW™, THUMB™, μ Vision™ of ARM Limited, UK. AUTOSAR™ is licensed by AUTOSAR development partnership. Bluetooth™ of Bluetooth SIG Inc. CAT-iq™ of DECT Forum. COLOSSUS™, FirstGPS™ of Trimble Navigation Ltd. EMV™ of EMVCo, LLC (Visa Holdings Inc.). EPCOS™ of Epcos AG. FLEXGO™ of Microsoft Corporation. FlexRay™ is licensed by FlexRay Consortium. HYPERTERMINAL™ of Hilgraeve Incorporated. IEC™ of Commission Electrotechnique Internationale. IrDA™ of Infrared Data Association Corporation. ISO™ of INTERNATIONAL ORGANIZATION FOR STANDARDIZATION. MATLAB™ of MathWorks, Inc. MAXIM™ of Maxim Integrated Products, Inc. MICROTEC™, NUCLEUS™ of Mentor Graphics Corporation. MIPI™ of MIPI Alliance, Inc. MIPS™ of MIPS Technologies, Inc., USA. muRata™ of MURATA MANUFACTURING CO., MICROWAVE OFFICE™ (MWO) of Applied Wave Research Inc., OmniVision™ of OmniVision Technologies, Inc. Openwave™ Openwave Systems Inc. RED HAT™ Red Hat, Inc. RFMD™ RF Micro Devices, Inc. SIRIUS™ of Sirius Satellite Radio Inc. SOLARIS™ of Sun Microsystems, Inc. SPANSION™ of Spansion LLC Ltd. Symbian™ of Symbian Software Limited. TAIYO YUDEN™ of Taiyo Yuden Co. TEAKLITE™ of CEVA, Inc. TEKTRONIX™ of Tektronix Inc. TOKO™ of TOKO KABUSHIKI KAISHA TA. UNIX™ of X/Open Company Limited. VERILOG™, PALLADIUM™ of Cadence Design Systems, Inc. VLYNQ™ of Texas Instruments Incorporated. VXWORKS™, WIND RIVER™ of WIND RIVER SYSTEMS, INC. ZETEX™ of Diodes Zetex Limited.

Last Trademarks Update 2011-11-11

1	Pin Configuration and Functionality	7
1.1	Pin Configuration	7
1.2	Pin Functionality	9
1.2.1	Pins of Sensor Interface	9
1.2.2	Pins of Serial and Parallel logic Interface	10
2	Blockdiagram	12
3	Functional Description	13
3.1	Introduction	13
3.2	Power Supply	13
3.2.1	Voltage Limits on VBB	14
3.2.2	External Supply	15
3.2.3	DC/DC Supply	16
3.3	Internal Oscillator	19
3.4	Sensor Input	20
3.4.1	Input Type Select	20
3.4.2	Wire Break Detection	22
3.5	Common Error Output	23
3.6	Programmable Digital Input Filter	25
3.7	Parallel Interface Mode	27
3.8	Serial Interface Mode	29
3.8.1	SPI Modes	30
3.8.2	Architecture of CRC-Engines	34
3.9	SYNC Operation	35
3.10	Write-Read- Access and Read-Read-Access for Different Applications	36
4	Standard Compliance	37
5	Electrical Characteristics	39
5.1	Absolute Maximum Ratings	39
5.2	Operating Conditions and Power Supply	40
5.3	Electrical Characteristics Input Side	42
5.4	Electrical Characteristics Microcontroller Interface	44
6	Registers of Microcontroller-Interface-Chip	49
6.1	μController Chip Registers Overview	49
6.2	Presentation of the Registers	50
6.2.1	Sensor Registers	50
6.2.2	Status Registers	50
6.2.3	Configuration Registers	51
6.3	μController Registers Description	52
6.3.1	Collective Diagnostics Register	52
6.3.2	Input Channel Data Register	52
6.3.3	Global Error Register	53
6.3.4	Filter Time of Channel 0-7 Register	54
6.3.5	Internal Error Register	55
6.3.6	Global Configuration Register	56
7	Package Outline	57

Isolated 8 Channel Digital Input with IEC61131-2 Type 1/2/3 Characteristics

Product Highlights

- Minimization of power dissipation due to constant current characteristic
- Status LED output for each input
- Digital averaging of the input signals to suppress interference pulses
- Isolation between Input and Output using Coreless Transformer Technology



Features

- Complete system integration (digital sensor or switch input, galvanic isolation and intelligent micro-controller or bus-ASIC interface)
- 8-channel input according to IEC61131-2 (Type 1/2/3)
- Integrated galvanic isolation 500VAC (EN60664-1, UL1577)
- 3.3V/5V SPI and parallel micro-controller interface
- Adjustable deglitching filters
- Up to 500 kHz sampling frequency
- Wire-break detection
- VBB under-voltage detection
- Package: TSSOP-48, 8 mm x 12.5 mm

Typical Application

Programmable Logic Controllers(PLC)
 Industrial PC
 General Control Equipment

Description

The ISO11813T is an electrically isolated 8 bit data input interface in TSSOP-48 package.

This part is used to detect the signal states of eight independent input lines according to IEC61131-2 Type 1/2/3 (e.g. two-wire proximity switches) with a common ground (GNDFI).

For operating sensors of type 1/2/3 in accordance with IEC61131-2, it is necessary for the device to be wired with resistors R_V and R_{EXT} (it is recommended to use resistors with an accuracy of 2%, in any case < 5% - is mandatory, temperature-coefficients < 200ppm are allowed).

An 8 bit parallel μC compatible interface allows to connect the IC directly to a μC system. The input interface is designed to operate with 3.3/5V CMOS compatible levels.

The data transfer from input to output side is realized by the integrated Coreless Transformer Technology.

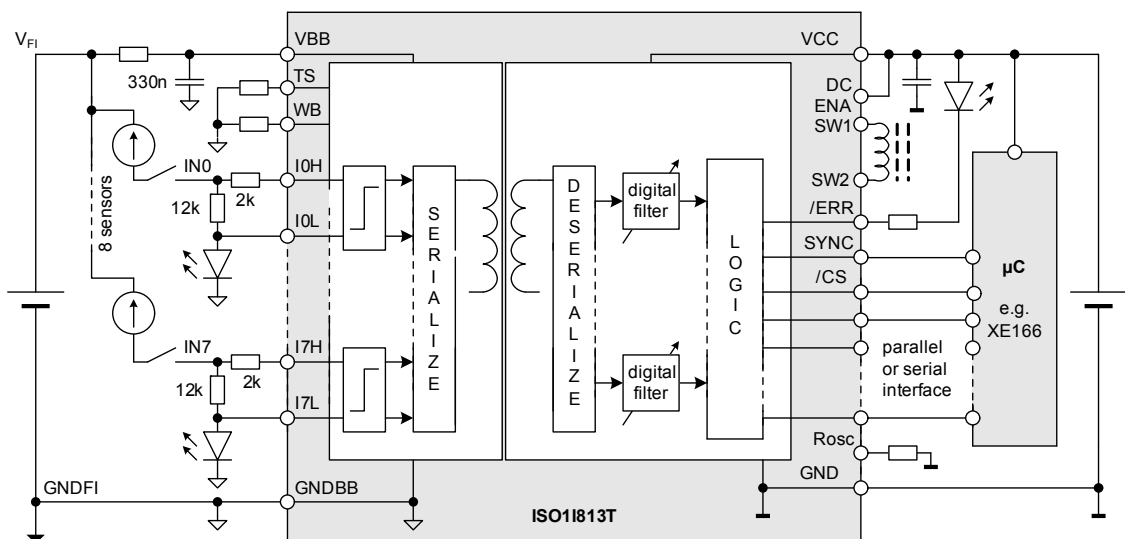

Typical Application for Sensor of Type 1/3

Pin Configuration and Functionality

1 Pin Configuration and Functionality

The pin configuration slightly differs for the parallel or the serial interface.

1.1 Pin Configuration

The ordering, type and functions of the IC pins are listed in the [Table 1](#).

Table 1 Pin Configuration

Pin	Parallel Interface Mode				Serial Interface Mode			
	Symbol	Ctrl 1)	Type 2)	Function	Symbol	Ctrl. 1)	Type 2)	Function
1	GND		A	Logic Ground	GND			
2	SEL	I	PU	Serial Parallel Mode Select	SEL			
3	SYNC	I	PU	Freeze Data & Diagnostics	SYNC			
4	Rosc		A	Clock Frequency Adjustment	Rosc			
5	VCC		A	Positive 5/3.3V logic supply	VCC			
6	ERR	O	OD, PU	Fault Indication output	ERR			
7	GND		A	Logic Ground	GND			
8	AD0	IO	PPZ	Data output bit0	SDI	I	PD	SPI Data input
9	AD1	IO	PPZ	Data output bit1	SSO	O	PPZ	SPI Status output
10	AD2	IO	PPZ	Data output bit2	GND			
11	AD3	IO	PPZ	Data output bit3	GND			
12	AD4	IO	PPZ	Data output bit4	CRCERR	O	OD, PU	CRC Error output
13	AD5	IO	PPZ	Data output bit5	SCLK	I	PD	SPI Shift Clock input
14	AD6	IO	PPZ	Data output bit6	SSI	I	PD	SPI Status input
15	AD7	IO	PPZ	Data output bit7	SDO	O	PPZ	SPI Data output
16	CS	I	PU	Chip Select	CS			
17	RD	I	PU	Data Read	n.c.			
18	GND		A	Logic Ground	GND			
19	WR	I	PU	Data Write	MS0	I	PD	SPI Mode Select bit 0
20	ALE	I	PD	Address Latch Enable	MS1	I	PD	SPI Mode Select bit 1
21	DC_ENA	I	PD	DC-DC Supply Enable	DC_ENA			
22	SW1		A	DC-DC Switch Output 1	SW1			
23	SW2		A	DC-DC Switch Output 2	SW2			
24	GND		A	Logic Ground	GND			
Sensor Side Pins								
25	GNDBB		A	Input Ground	GNDBB			
26	VBB		A	Positive input supply voltage	VBB			
27	I0L		A	Input 0 Low, LED Out	I0L			
28	I0H		A	Input 0 High	I0H			
29	I1L		A	Input 1 Low, LED Out	I1L			
30	I1H		A	Input 1 High	I1H			

Pin Configuration and Functionality

Table 1 Pin Configuration

Pin	Parallel Interface Mode				Serial Interface Mode			
	Symbol	Ctrl 1)	Type 2)	Function	Symbol	Ctrl. 1)	Type 2)	Function
31	GNDBB		A	Input Ground	GNDBB			
32	I2L		A	Input 2 Low, LED Out	I2L			
33	I2H		A	Input 2 High	I2H			
34	I3L		A	Input 3 Low, LED Out	I3L			
35	I3H		A	Input 3 High	I3H			
36	TS		A	Sensor Type 1/2/3 Select	TS			
37	GNDBB		A	Input Ground	GNDBB			
38	WB		A	Wire Break Select	WB			
39	I4L		A	Input 4 Low, LED Out	I4L			
40	I4H		A	Input 4 High	I4H			
41	I5L		A	Input 5 Low, LED Out	I5L			
42	I5H		A	Input 5 High	I5H			
43	GNDBB		A	Input Ground	GNDBB			
44	I6L		A	Input 6 Low, LED Out	I6L			
45	I6H		A	Input 6 High	I6H			
46	I7L		A	Input 7 Low, LED Out	I7L			
47	I7H		A	Input 7 High	I7H			
48	GNDBB		A	Input Ground	GNDBB			

1) Direction of the pin: I = input, O = output, IO = Input/Output

2) Type of the pin: A = analog, OD = Open-Drain, PU = internal Pull-Up resistor, PD = internal Pull-Down resistor, PPZ = Push-Pull pin with High-Impedance functionality

Pin Configuration and Functionality

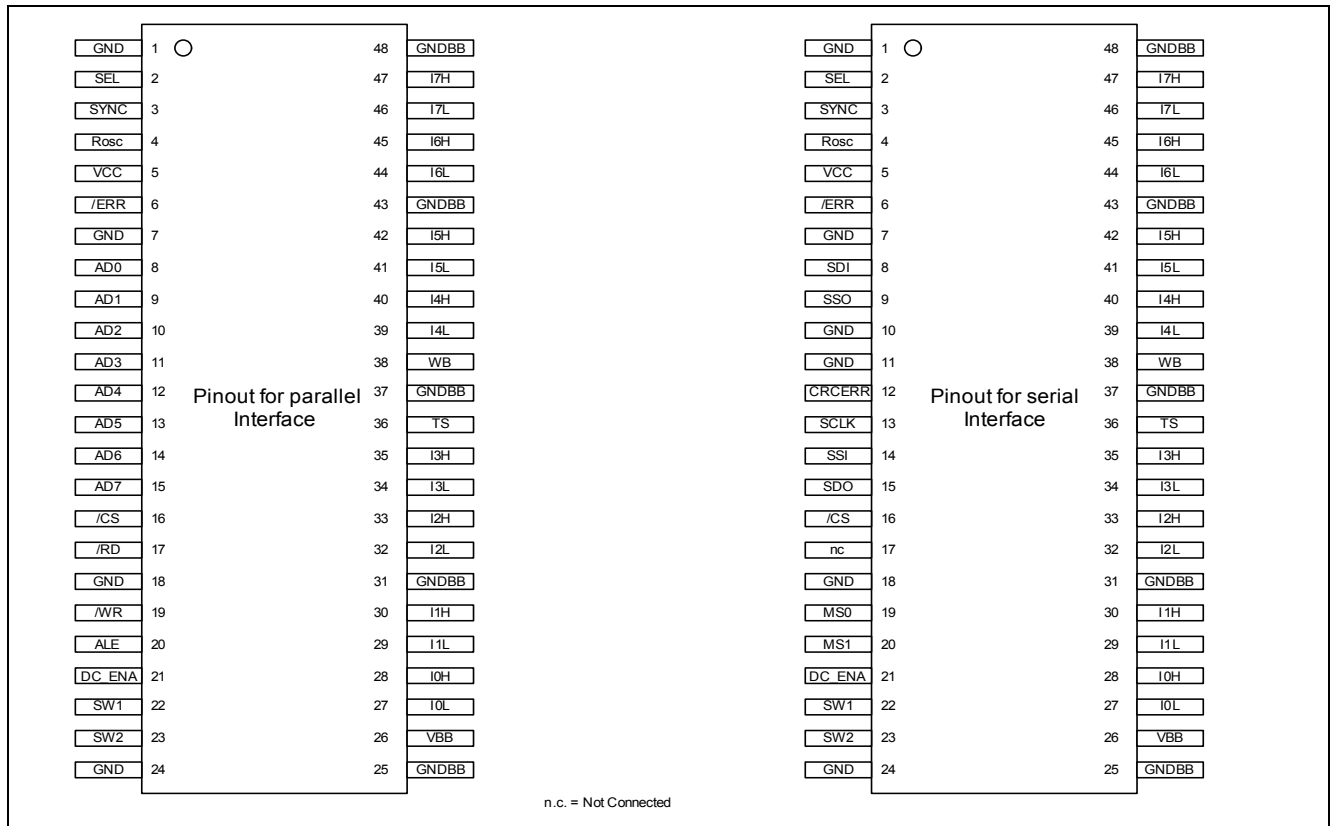

Figure 1 TSSOP-48 Pinout for Parallel and Serial Interface Modes

1.2 Pin Functionality

1.2.1 Pins of Sensor Interface

VBB (Positive supply 9.6-35V sensor supply)

VBB supplies the sensor input stage.

GNDDBB (Ground for VBB domain)

This pin acts as the ground reference for the sensor input stage that is supplied by VBB.

I0H... I7H (Input channel 0 ... 7)

Sensor inputs with current sink characteristic according IEC61131-2 Type 1/2/3 which has been selected by pin TS

I0L... I7L (LED output channel 0 ... 7)

This pin provides the output signal to switch on the LED if the input voltage and current has been detected as "High" according to the selected type.

WB (Wire-Break Select)

By connecting a resistor between pin WB and pin GNDDBB, the level for the Wire-Break detection can be adjusted (refer to [Table 10](#) for corresponding resistor value). This pin is for static configuration (pin-strapping). The input voltage at pin WB is not allowed to be changed during operation.

TS (Type Select)

By connecting a resistor between TS and GNDDBB the sensor type (Type 1/2/3) can be selected (refer to [Table 10](#) for corresponding resistor value). This pin is for static configuration (pin-strapping). The input voltage at pin TS is not allowed to be changed during operation.

Pin Configuration and Functionality

1.2.2 Pins of Serial and Parallel logic Interface

Some pins are common for both interface types, some others are specific for the parallel or serial access.

VCC (Positive 3.3/5V logic supply)

VCC supplies the output interface that is electrically isolated from the sensor input stage. The interface can be supplied with 3.3/5V.

GND (Ground for VCC domain)

This pin acts as the ground reference for the uC-interface that is supplied by pin VCC.

Rosc (Clock Adjustment)

A high precision resistor has to be connected between pin Rosc and pin GND to set the frequency of the sampling clock.

DC_ENA (DC-DC Converter Enable)

When the DC_ENA pin is connected to VCC, the internal DC-DC driver is activated. When DC_ENA is in the state Low, the switches are not driven. The input voltage must not change during operation. This pin has an internal Pull-Down resistor.

SW1, SW2 (DC-DC switch outputs 1/2)

When the pin DC_ENA is connected to VCC, the outputs SW1 and SW2 switch at the clock-frequency determined by the resistor at pin Rosc to supply the external push-pull converter. The switching frequency can be divided by two by setting the responsible bit in the GLCFG register (see also [Chapter 6](#)). Both outputs provide an open drain functionality.

$\overline{\text{ERR}}$ (Error)

The active Low $\overline{\text{ERR}}$ signal contains the OR-wired information of the sensor input undervoltage and missing voltage detection, the internal data transmission failure detection unit and the overcurrent fault of the DC-DC-converter. The output pin $\overline{\text{ERR}}$ provides an open drain functionality. During Start Up this pin $\overline{\text{ERR}}$ is pulled to High. This pin $\overline{\text{ERR}}$ has an internal Pull-Up resistor. In normal operation the signal $\overline{\text{ERR}}$ is High. See [Chapter 3.5](#) for more details.

SEL (Serial or Parallel Mode Select)

When this pin is in a logic Low state, the IC operates in Parallel Mode. For Serial Mode operation the pin has to be pulled into logic High state. During Start Up the IC is operating in Serial Mode. This pin has an internal Pull-Up resistor. This pin must not change during operation.

SYNC

When this pin is in a logic High state, the IC operates in continuous mode with the internal sampling clock. In isochronous mode, the internal data and diagnostics registers are synchronized on each falling edge detected at SYNC. The internal data and diagnostics registers are frozen with the falling edge of SYNC. In logic Low state the internal data and diagnostic registers are not updated. During Start-Up this pin is pulled to High state. This pin has an internal Pull-Up resistor. (see also [Chapter 3.9](#))

$\overline{\text{CS}}$ (Chip Select)

When the pin $\overline{\text{CS}}$ pin is logic Low, the IC interface is enabled and data can be transferred. This pin $\overline{\text{CS}}$ has an internal Pull-Up resistor.

Pin Configuration and Functionality

The following pins are provided in the parallel interface mode

AD7:AD0 (AddressData input / output bit7 ... bit0)

The pins AD0 .. AD7 are the bidirectional input / outputs for data write and read. Depending on the state of the pins ALE, \overline{RD} , \overline{WR} and the AD7 bit register addresses or data can be transferred between the internal registers and the parallel interface of a e.g. micro-controller .

\overline{RD} , \overline{WR} (Read / Write)

By pulling one of these pins down, a read or write transaction is initiated on the AddressData bus and the data becomes valid. These pins have internal Pull-Up resistors.

ALE (Address Latch Enable)

The pin ALE is used to select between address (ALE is in a logic High state) or data (ALE is in a logic Low state). Furthermore, a read or write transaction can be selected in conjunction with the AD7 bit. When ALE is pulled high, addresses are transferred and latched over the bit AD0 to AD6. The AD7 bit serves for a read access (AD7 is Low) or a write access (AD7 is High) at this address. During the Low State of ALE all transactions hit the same address. This pin has an internal Pull-Down resistor.

The following pins are provided in the serial interface mode

MS0, MS1 (Serial Mode Select)

By driving the pins MS, MS1 to Logic High or Logic Low the Serial Interface Mode can be selected. These pins have internal Pull-Down resistors. The mode of the Serial Interface can be changed by the user during operation.

SCLK (Serial interface shift clock)

Input data are sampled with the rising edge and output data are updated with the falling edge of this input clock signal. This pin SCLK has an internal Pull-Down resistor.

SDI, SSI (Serial interface data/status input)

SDI/SSI data is put into a dedicated FIFO to program the filtering time and mask the Wire-Break diagnostic bits of each channel (SPI Mode 2 and 3). It is also used to set the address of the register, which is intended to be accessed. This pin has an internal Pull-Down resistor.

SDO, SSO (Serial interface data/status outputs)

SDO provides the sensor data bits and or the register content, SSO provides the sensor diagnostics bits.

\overline{CRCERR} (CRC Error output)

This pin \overline{CRCERR} is in a logic Low state when CRC errors or Shift-Clock errors are detected internally. This pin \overline{CRCERR} provides an open drain functionality. This pin has an internal Pull-Up resistor.

2 Blockdiagram

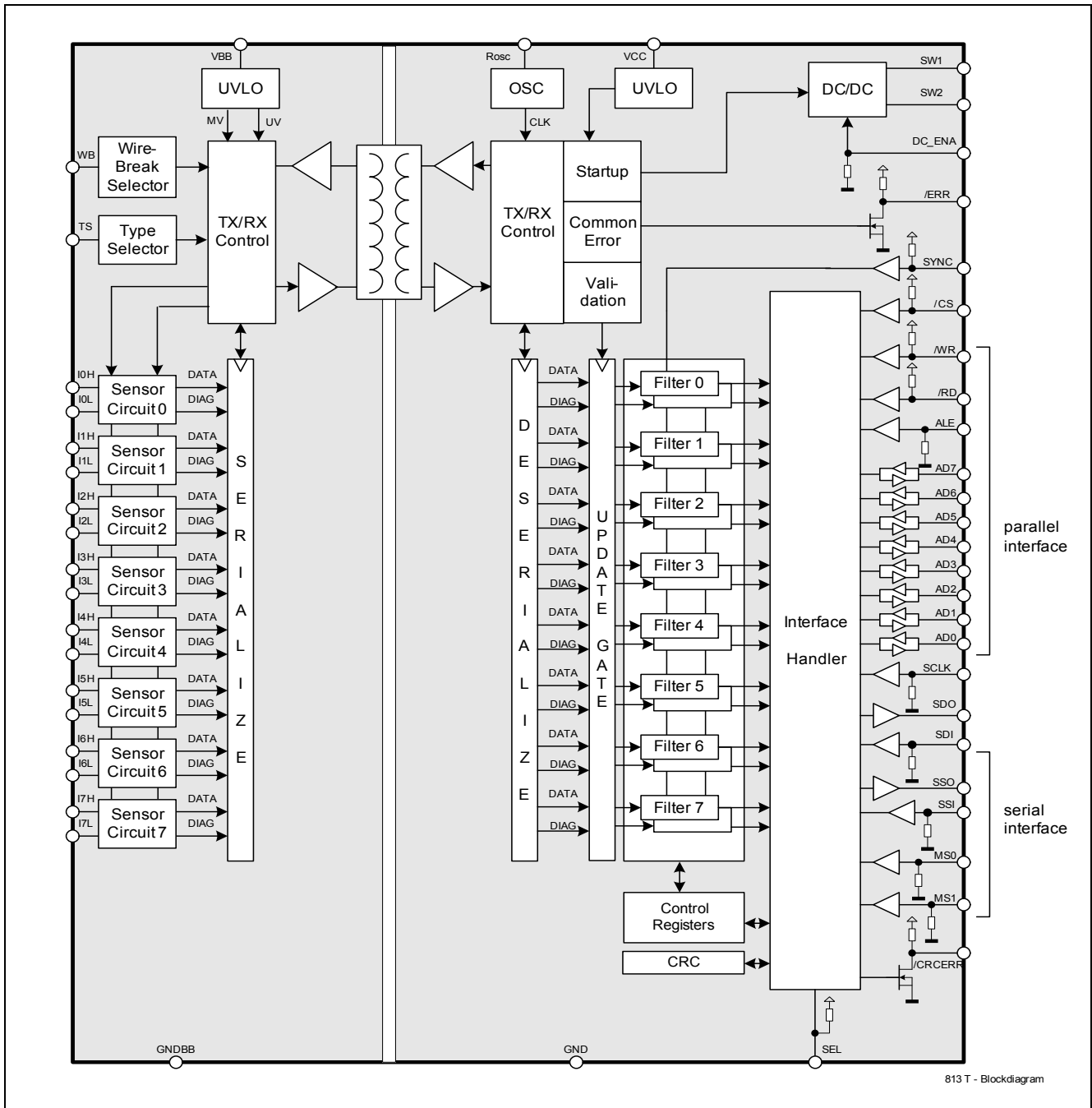

Figure 2 Block Diagram ISO11813T

3 Functional Description

The ISO11813T is an electrically isolated 8 bit data input interface. This part is used to detect the signal states of eight independent input lines according to IEC61131-2 Type 1/2/3 (e.g. two-wire proximity switches) with a common ground (GNDBB).

3.1 Introduction

The current in the input circuit is determined by the switching element in state “0” and by the characteristics of the input stage in state “1”.

The octal input device is intended for a configuration comprising two specified external resistors per channel, as shown in [Figure 10 “Typical Application for Sensor Input Type 1, 2 and 3” on Page 20](#). As a result the power dissipation within the package is at a minimum.

The voltage dependent current through the external resistor R_{EXT} is compensated by a negative differential resistance of the current sink across pins IxH and IxL, therefore input INx behaves like a constant current sink.

The comparator assigns level 1 or 0 to the voltage present at input IxH. To improve interference protection, the comparator is provided with hysteresis. A status LED is connected in series with the input circuit (R_{EXT} and current sink).

If no LED is used an external resistor of 2 k Ω (type 1 and 3) has to be connected between IxL and GNDBB. The specified switching thresholds may change if the LED is replaced by a resistor.

The internal LED drive short-circuits the status LED if the comparator detects “0”. A constant current sink in parallel with the LED reduces the operating current of the LED, and a voltage limiter ensures that the input circuit remains operational if the LED opens, but the switching thresholds may change.

For each channel an adjustable digital filter is provided which samples the comparator signal at a rate configured by programming internal registers. The digital filter is designed to provide averaging characteristics. If the input value remains the same for the selected number of sampling values, then the output changes to the corresponding state.

The μ C compatible interfaces allow a direct connection to the ports of a microcontroller without the need for other components. The diagnostic logic on the chip monitors the internal data transfer as well as the sensor input supply. The information is sent via the internal coreless transformer to the pin \overline{ERR} at the input interface

3.2 Power Supply

The IC contains two electrically isolated voltage domains that are independent from each other. The microcontroller interface is supplied via pin VCC, GND and the input stage is supplied via pin VBB, GNDBB. The different voltage domains can be switched on at different times. [Figure 4](#) shows the Start Up behaviour if both voltage domains are powered by an external power supply. If the VCC and VBB voltage have reached their operating range and the internal data transmission has been started successfully, the IC indicates the end of the Start Up procedure by setting the pin \overline{ERR} to logic low. In the situation of a supply voltage drop at VBB on the Sense Side - even short - the Sense Chip requires a proper restart and therefore the μ Controller Side control unit needs to react accordingly, especially to guarantee the integrity of the sensor data provided to the filter stage.

3.2.1 Voltage Limits on VBB

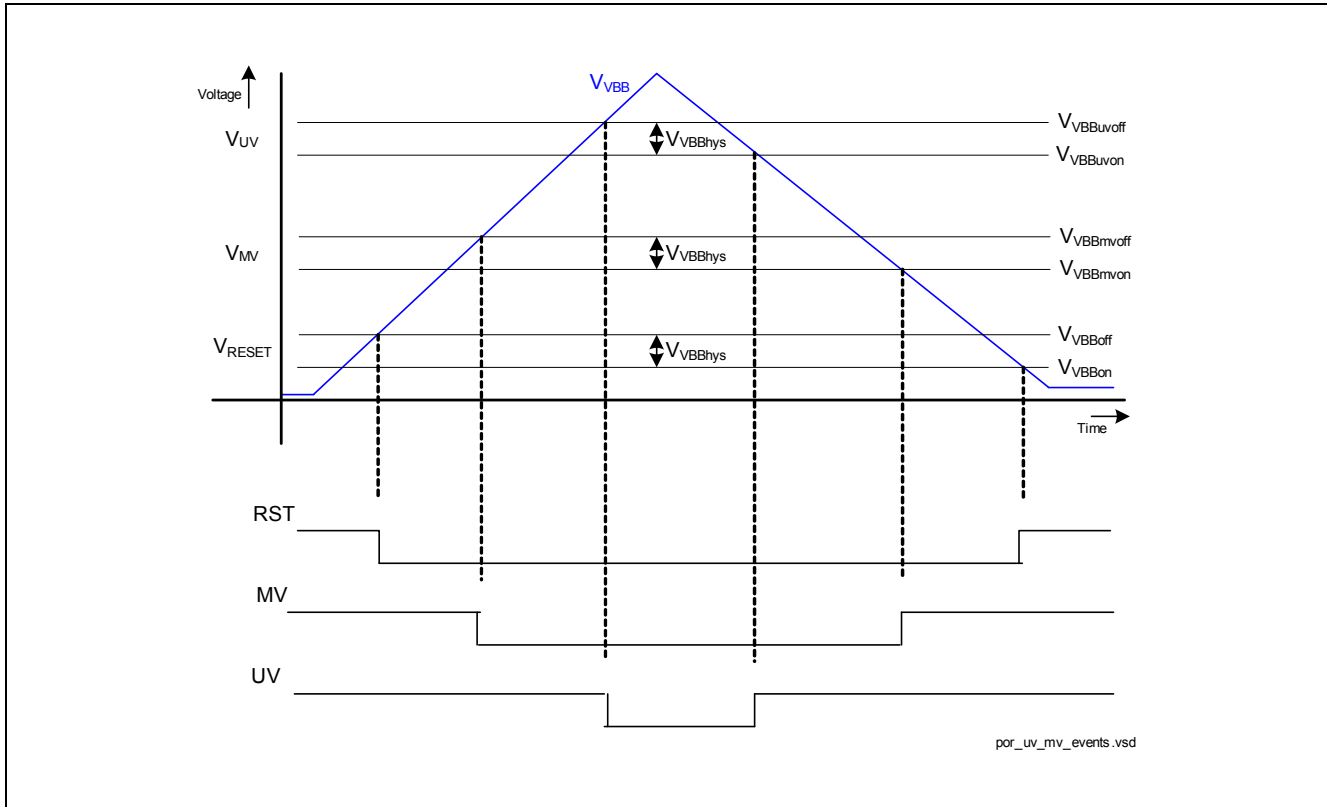

Figure 3 Start Up Procedure with external Power Supply

During UVLO, all registers are reset to their reset values as specified in the [Chapter 6.2](#). As a result, the flags TE, UV as well as MV are High and the ERR pin is Low (error condition). Immediately after the reset is released, the IC is first configured by “reading” the logic level of the SEL, MS1, MS0 (when available). The IC powers up as a serial device (SEL has a pull-up resistor).

The supply voltage VBB is monitored during operation by two internal comparators (with typ. 8 μ s blanking time @ 500kHz $f_{scantyp}$) detecting:

- VBB Undervoltage: If the voltage drops below the UV threshold (see [Table 7](#)), the UV-bit in the **GLERR** register is set High. The IC remains in normal operation.
- VBB Missing Voltage: If the voltage further drops below the MV threshold, lower than the previous threshold, the MV-bit in the **GLERR** register is set, the Sense Side of the IC is turned off when reaching the V_{RESET} threshold whereas the Micro-Controller Side remains active.

These 2 thresholds are inactive when the IC operates in Self Power Mode i.e. when the DC_ENA pin is High.

Note: In case DC_ENA is High the integrated DC/DC driver is active. The driver stage is self-protected in overload condition: the internal switches will be turned off as long as the overcurrent condition is detected and the IC will automatically restart once the overload condition disappears.

Important: Since the UV and MV (as well as the TE and W4S) bits used for generating the $\overline{\text{ERR}}$ signal are preset to High during UVLO, the $\overline{\text{ERR}}$ pin is Low after power up. Therefore the $\overline{\text{ERR}}$ signal requires to be explicitly cleared after power up. At least one read access to the GLERR and INTERR registers is needed to update those status bits and thus release the $\overline{\text{ERR}}$ pin.

3.2.2 External Supply

Figure 4 shows the Start Up behaviour if both voltage domains are powered by an external power supply. If the VCC and VBB voltage have reached their operating range and the internal data transmission has been started successfully, the IC indicates the end of the Start Up procedure by setting the pin $\overline{\text{ERR}}$ to logic high.

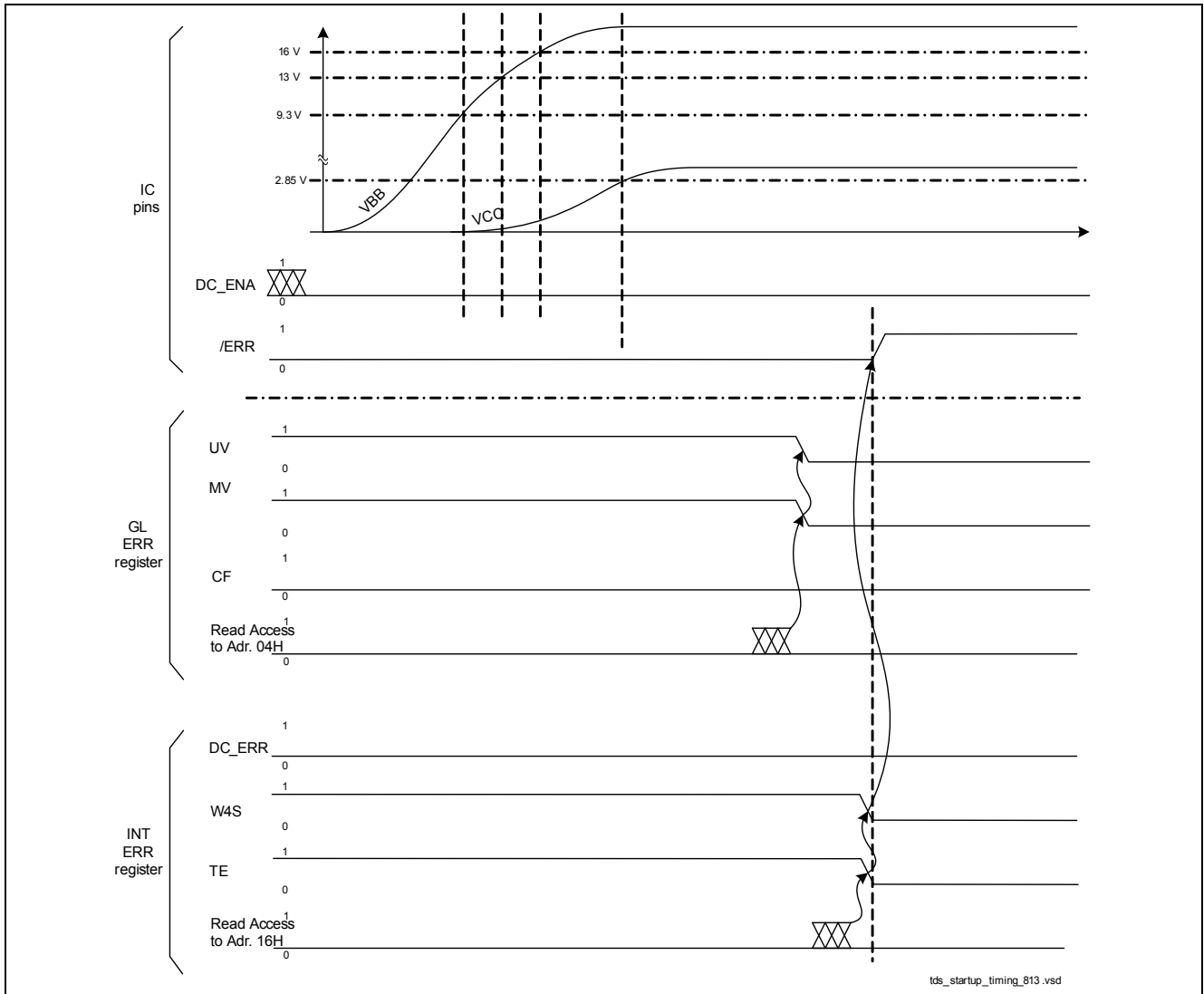

Figure 4 Start Up procedure with external power supply

3.2.3 DC/DC Supply

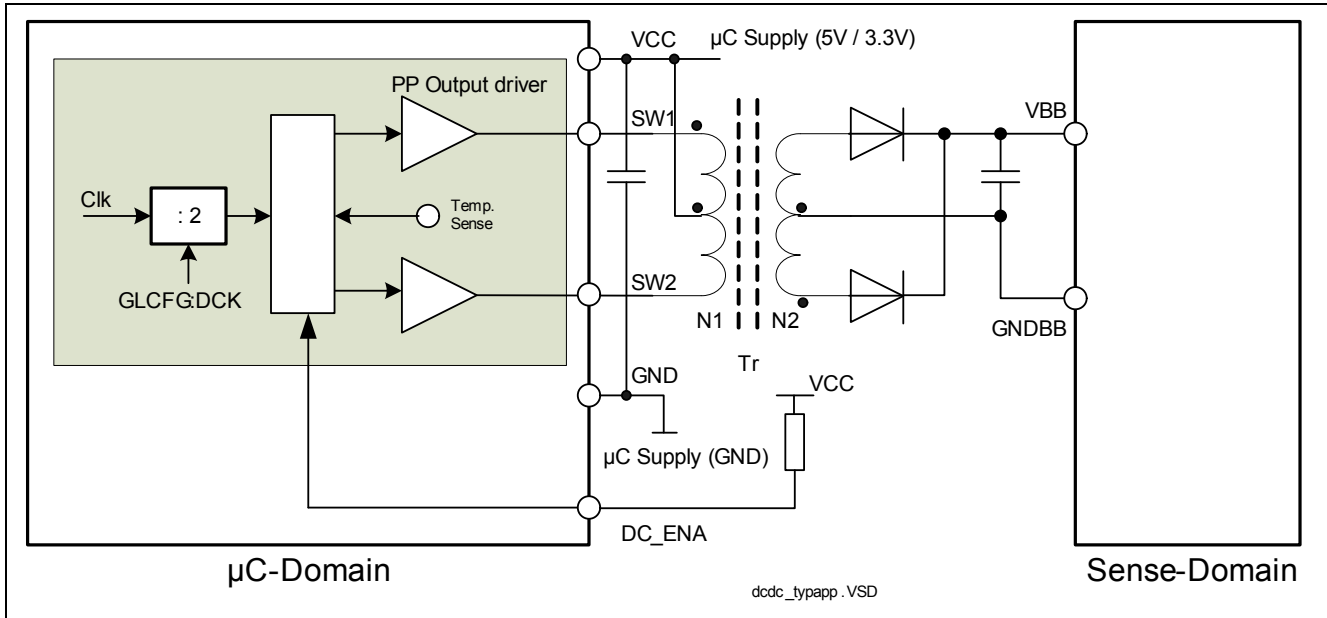

Figure 5 Typical Circuitry for Self Powered Mode with Push-Pull Converter

The IC can as well operate in self powered mode. In this case, the Process Side (Sense-Domain) can be supplied at VBB with an isolated push-pull converter connected to the Micro-controller Side and driven by the pins SW1 and SW2 . The internal driver stage at SW1 and SW2 is designed to power up two ISO1I813T (refer to [Table 8](#)). The DC/DC-Converter is driven by the internal clock. Parameters are calculated with the internal clock of 500 kHz. By setting the DCK Bit in the GLCFG register a prescaler by 2 can be activated. Should the user adjust the internal clock to a different frequency the transformer has to be adjusted accordingly.

The short-circuit protection uses a temperature sensor located close to the drivers and disables the driver stages when a predefined temperature is reached ([Figure 7](#), [Figure 5](#)). The target value for the switch-off-temperature is 160°C with a hysteresis of < 10°C. That means that the drivers are switched off at a junction temperature of 160 °C and switched on at a junction temperature of <=150°C

Functional Description

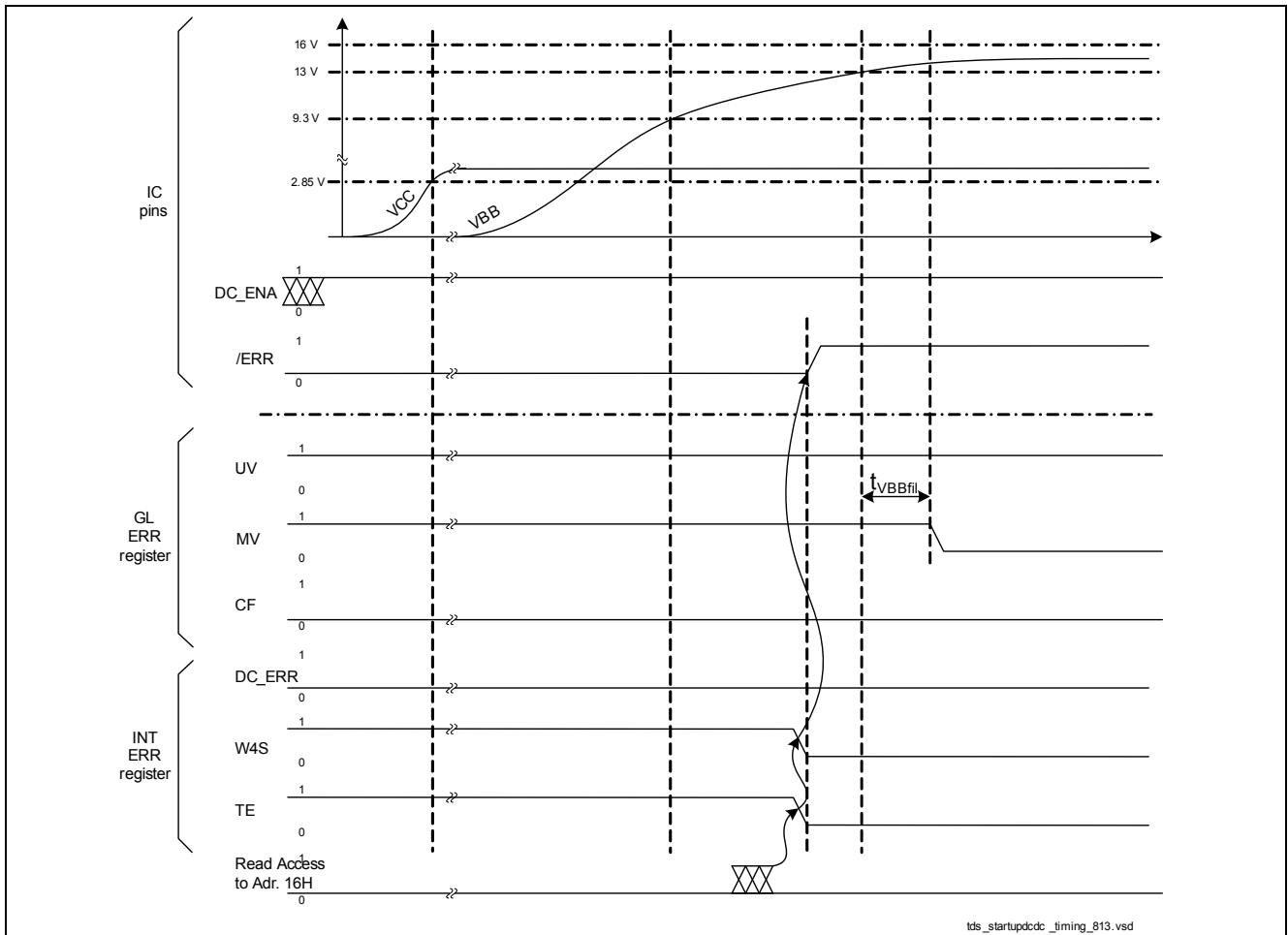

Figure 6 Start Up Procedure with DC/DC Supply

Functional Description

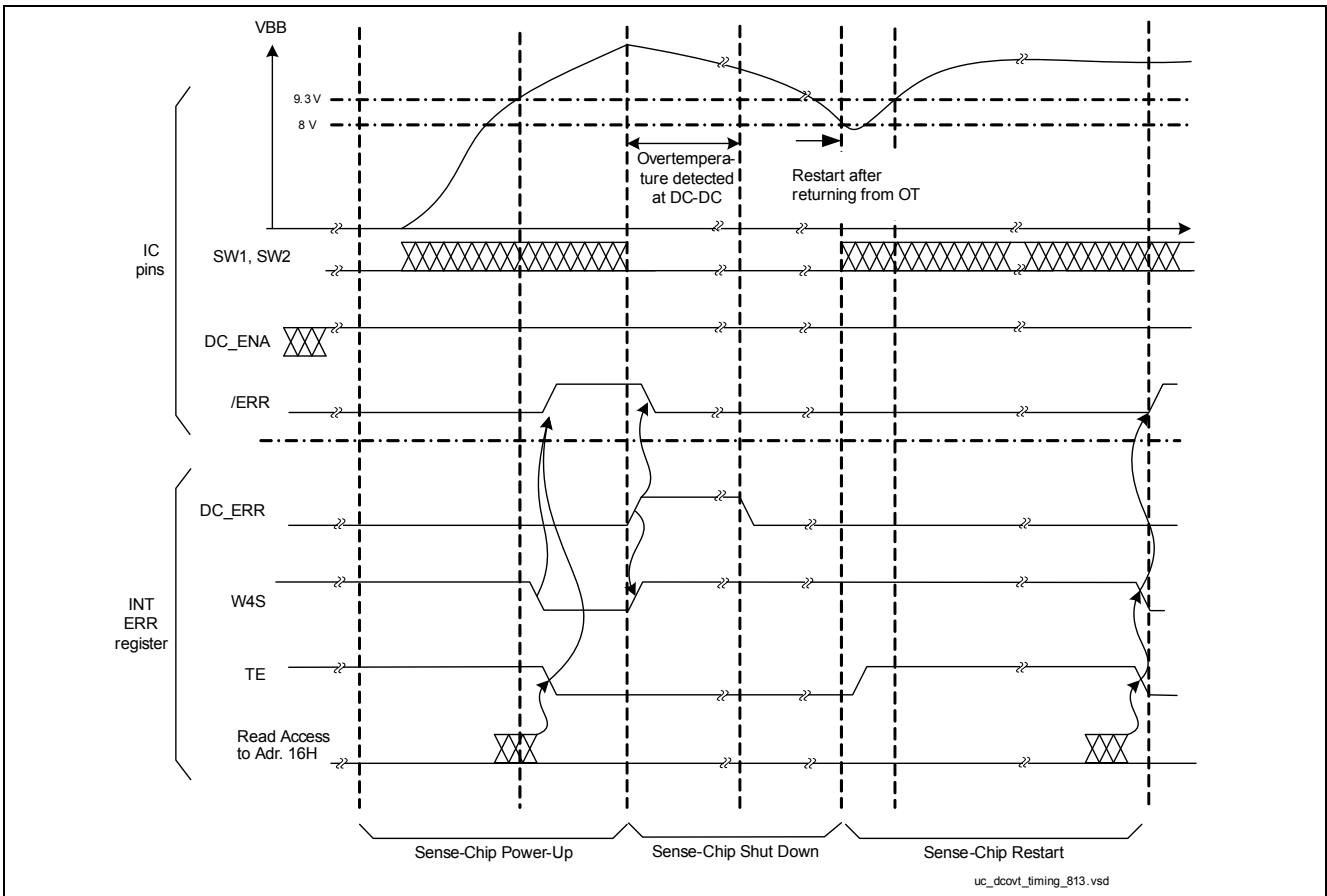

Figure 7 Restart Procedure after VBB drop due to DC/DC Supply Overtemperature

3.3 Internal Oscillator

An external resistor has to be connected to R_{osc} and allows the adjustment of the frequency as shown in [Figure 8](#).

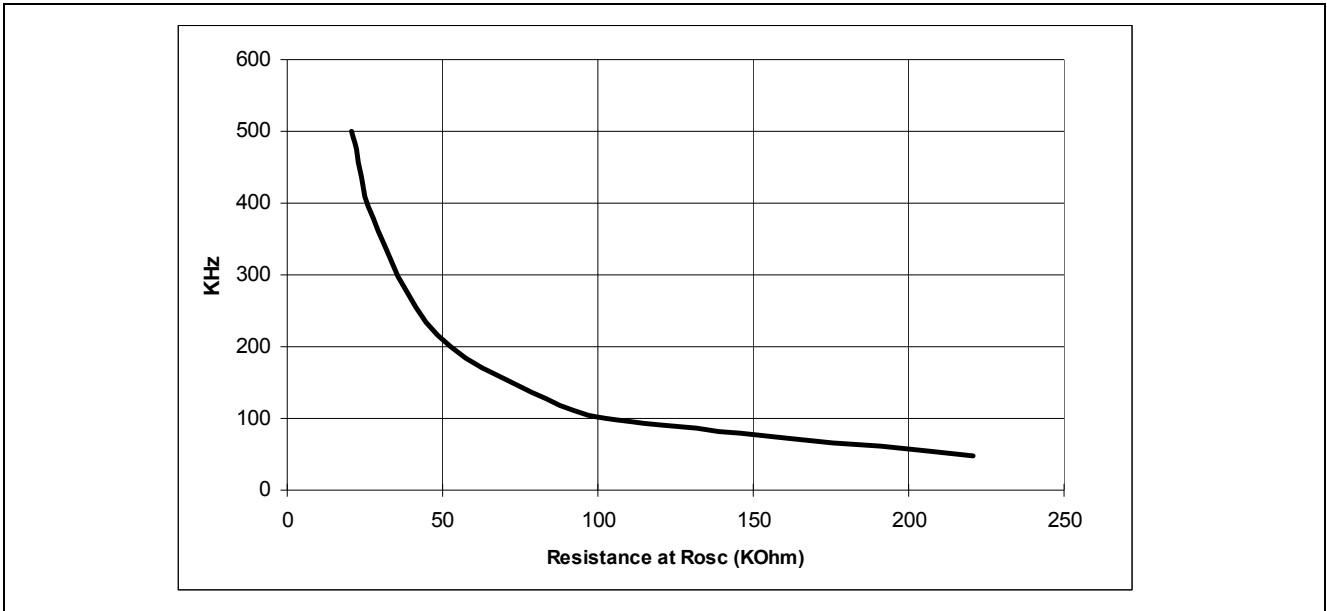

Figure 8 Internal Frequency Setting at R_{osc}

The internal oscillator provides the scan clock for the sampling of the sensor data and diagnostics as well as for the internal digital averaging filters. Therefore the filter times as defined in the [Table 11](#) for the typical frequency of 500 KHz will change accordingly. As an example, it is possible to define filter time longer than 20 ms by reducing the internal oscillator frequency.

Moreover, in the applications where the IC current consumption is critical, it is possible to reduce the internal oscillator frequency by increasing the R_{OSC} (see [Figure 9](#)).

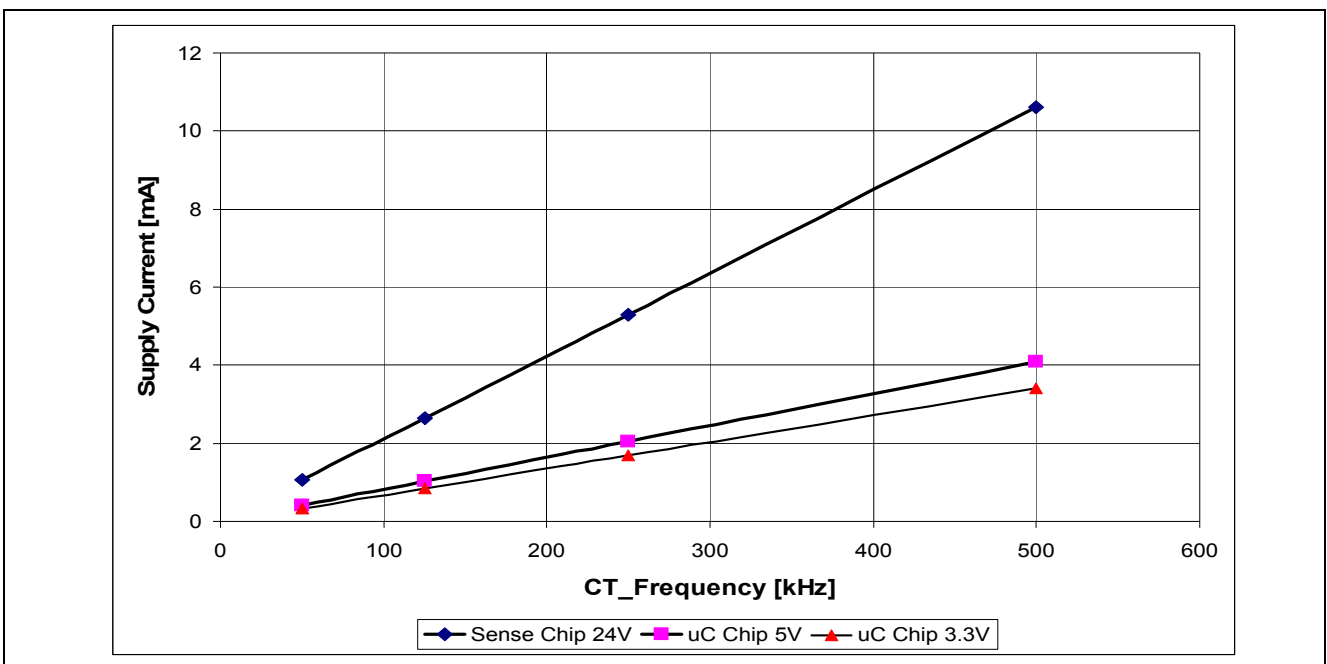

Figure 9 IC Current Consumption in function of the internal frequency

3.4 Sensor Input

3.4.1 Input Type Select

The sensor input structures are shown in **Figure 10** (Type 1,2,3). Due to its active current a V-I-characteristic as shown in **Figure 11** is maintained. This V-I-curve is well within the IEC 61131 standard requirements of Type 1, Type 2 and Type 3 sensors, respectively. The **Figure 12** shows the typical application for sensor of type 2. It is recommended to choose for the external resistors R_{EXT} , R_V , R_{LED} an accuracy of 2 % (< 5% is mandatory) otherwise the V/I-characteristic shown in **Figure 11** cannot be guaranteed.

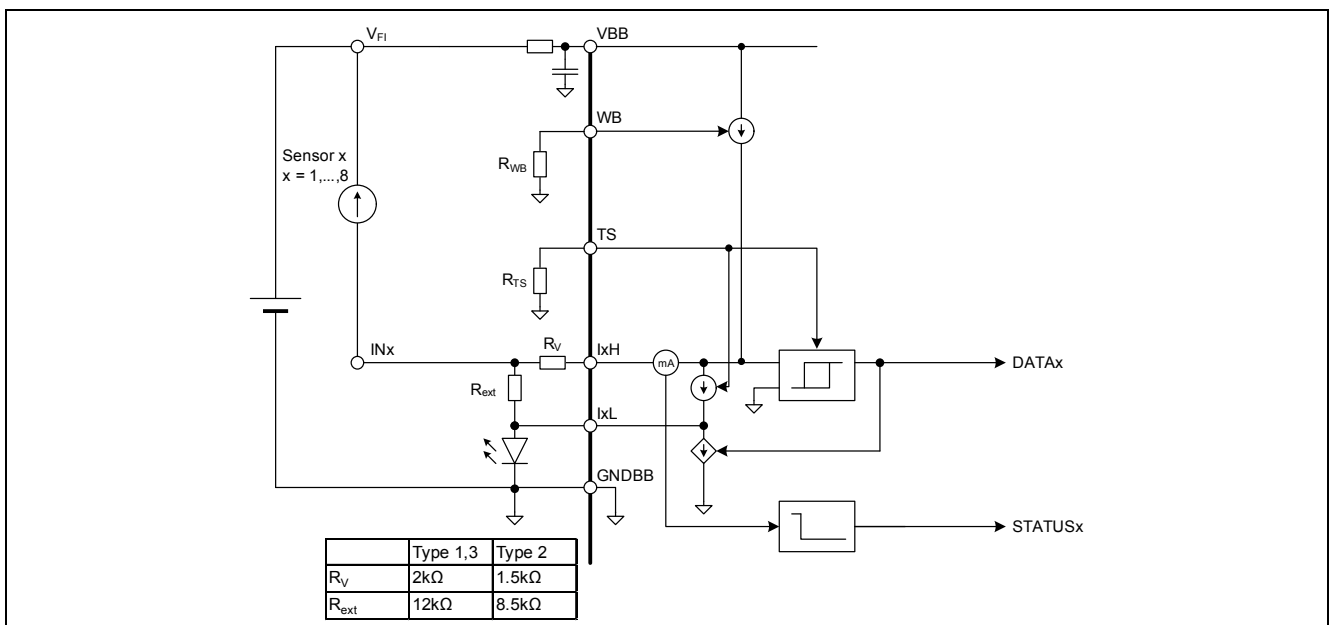

Figure 10 Typical Application for Sensor Input Type 1, 2 and 3

The filtered input-data information is visible in the Input Channel Data Register : **INPDATA** and is also described by the nomenclature : input-data.

Functional Description

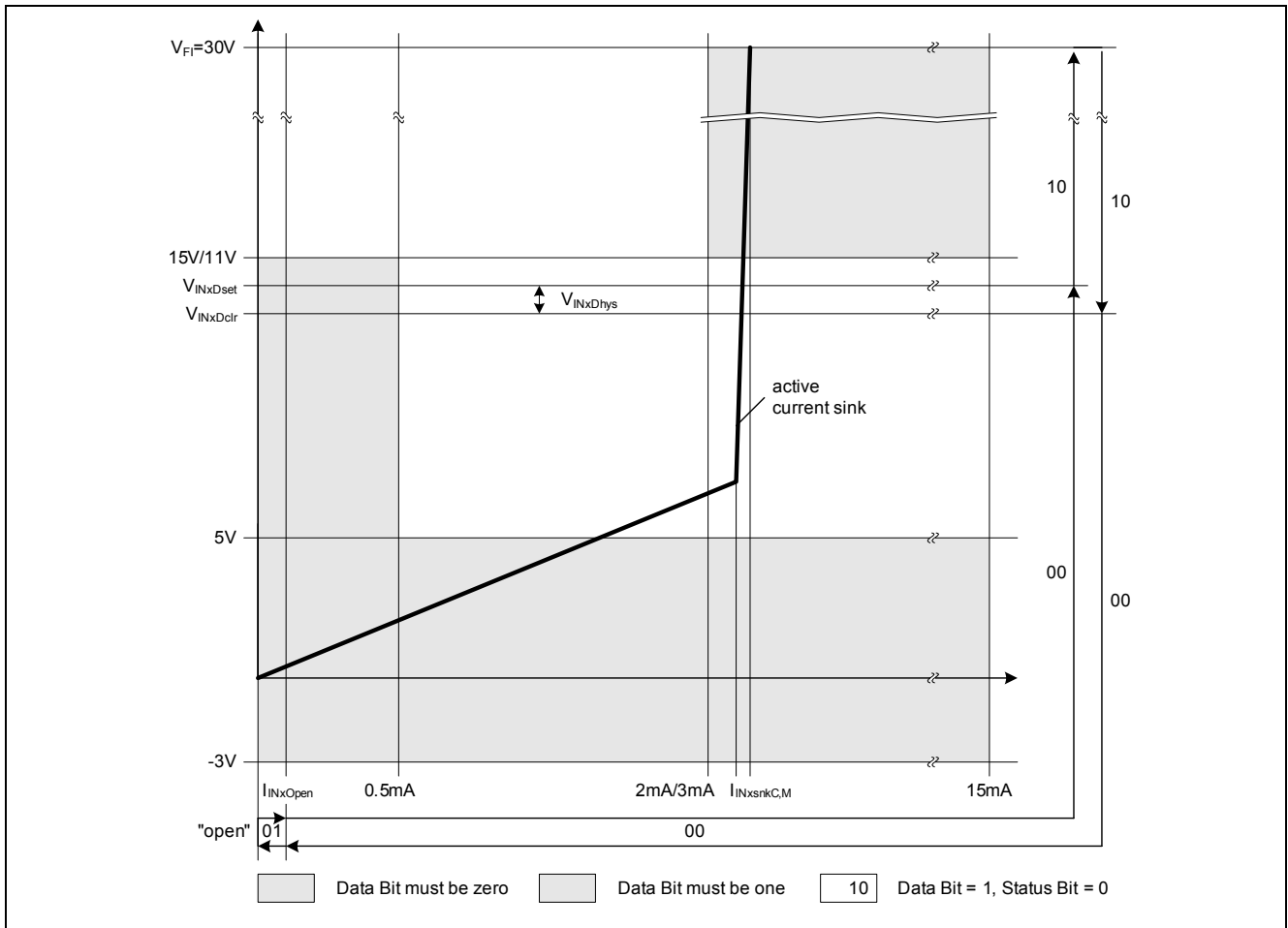

Figure 11 Sensor Input Characteristics

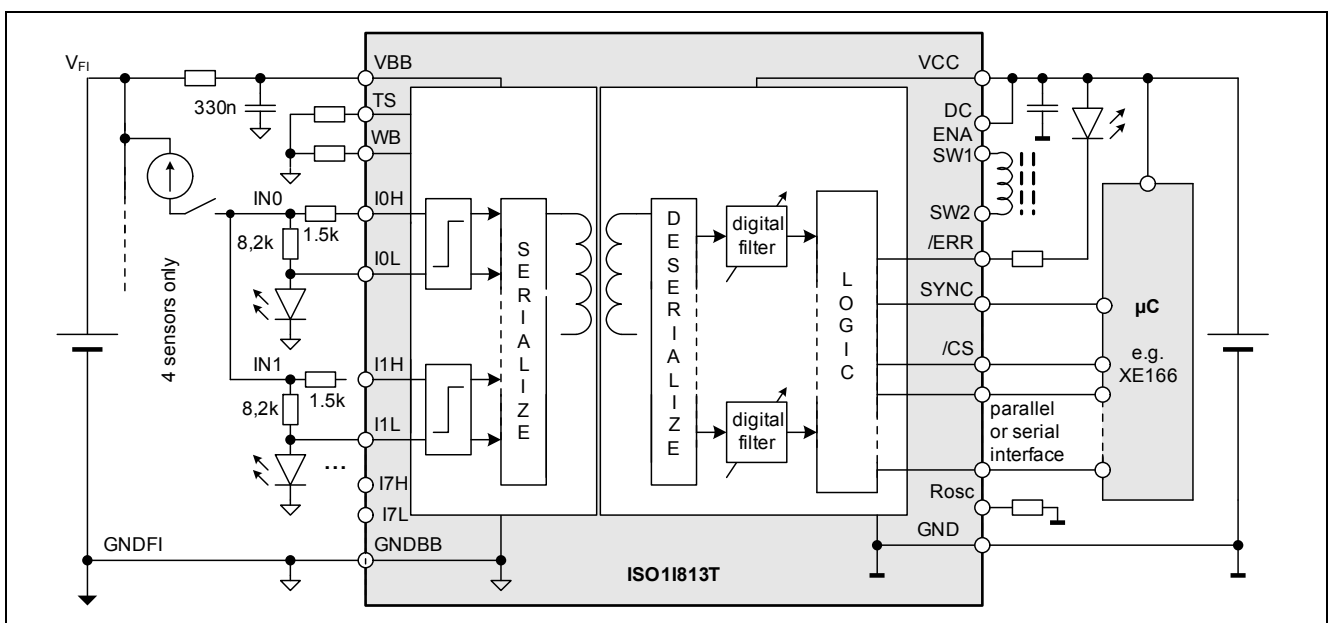

Figure 12 Typical Application for Sensor Type 2

3.4.2 Wire Break Detection

The wire-break current can be adjusted by the R_{WB} -resistor value connected to the pin WB (Figure 13). The minimum wirebreak-current can be chosen only when a LED- or Zener-Diode is connected to the pin IxL with a forward current in the range of few μA in the voltage range below 1 V. In the case of a connected resistor at IxL a large current is flowing across the external resistor R_{ext} and the IxL-resistor (R_{LED}). This part cannot be measured internally and has to be added to the internal current part. In this case the minimum adjustable current is 230 μA ($R_{LED} = 2k\Omega$). The WB bits in the status register have a sticky (latched) property and remains set as long as they are not cleared by a read access and the fault condition is not detected anymore.

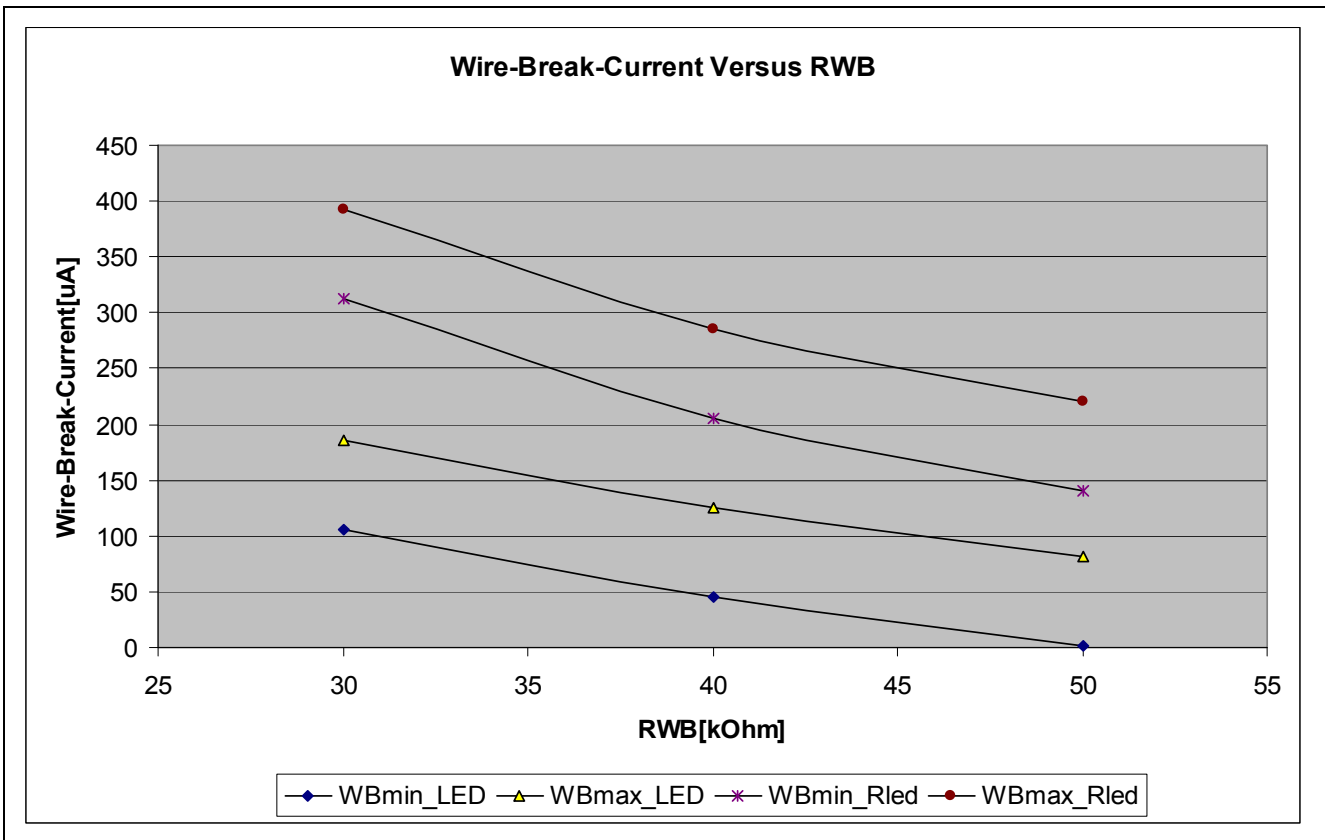

Figure 13 Wire Break Detection for Type 1,3 (typ. @ 25°C)

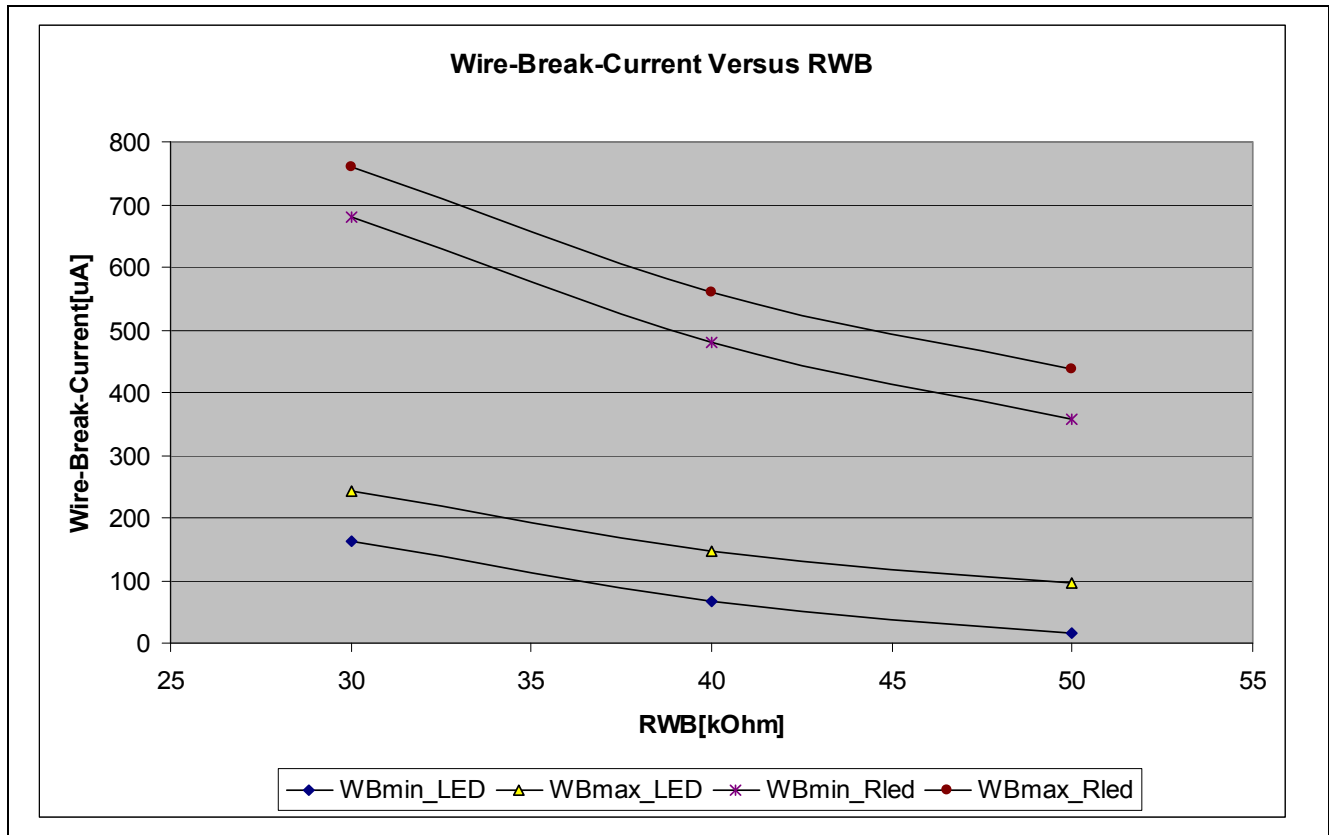

Figure 14 Wire Break Detection for Type 2 (typ. @ 25°C)

In the case of Type 2 two sense inputs are switched in parallel to achieve $2 * 3 \text{ mA}$ (Figure 12). In each sense input a minimum wirebreak current of $60 \mu\text{A}$ can be measured which means in sum a minimum wirebreak current of $120 \mu\text{A}$. It is not recommended to use external resistors at the pins IxL in case of wirebreak measurements. The recommended value would be $R_{\text{LED}} = 1.2 \text{ k}\Omega$ which has been chosen in order not to produce a large voltage drop between IxL and GNDBB which in turn would limit the voltage drop across the sink. The low value of R_{LED} would cause a high external current in case of wirebreak-measurements which has to be multiplied by two due to the parallel circuitry of the sense inputs.

The filtered wirebreak-diagnosis is visible in the Collective Diagnostic Register : **DIAG** and is also described by the nomenclature: status.

3.5 Common Error Output

The input (VBB) undervoltage and missing voltage status which are transmitted via the integrated coreless transformer to the output block and the internal data transmission monitoring information are evaluated in the common error output block, see Figure 15. In self-powered mode, extra information in case of over-current at SW1/2 is evaluated as well.

In case of an internal data transmission error the data and status bits are replaced by the last valid transmission. Moreover, if four consecutive erroneous data transmissions ($\text{TE1}=1$) occur, an internal error signal ($\text{TE4}=1$) is set. The averaging filters are reset and this status is held until four consecutive error-free transmissions ($\text{TE1}=0$) occur. An example timing diagram is shown in Figure 15.

This internal error signal is OR-wired with the current VBB undervoltage and missing voltage status. Additionally in the ISO11813T, the Collective Diagnostics flag is combined in the ERR. Since the output error signal is active-Low, the OR-wired result is negated.

Functional Description

In the Self Powered mode, the UV and MV are masked out. Instead the DC_ERR bit of the register **INTERR** is combined with the Transmission Error signal and output at the pin $\overline{\text{ERR}}$.

The output stage at pin $\overline{\text{ERR}}$ has an open drain functionality with a pull-up resistor. See **Table 13** for the electrical characteristics.

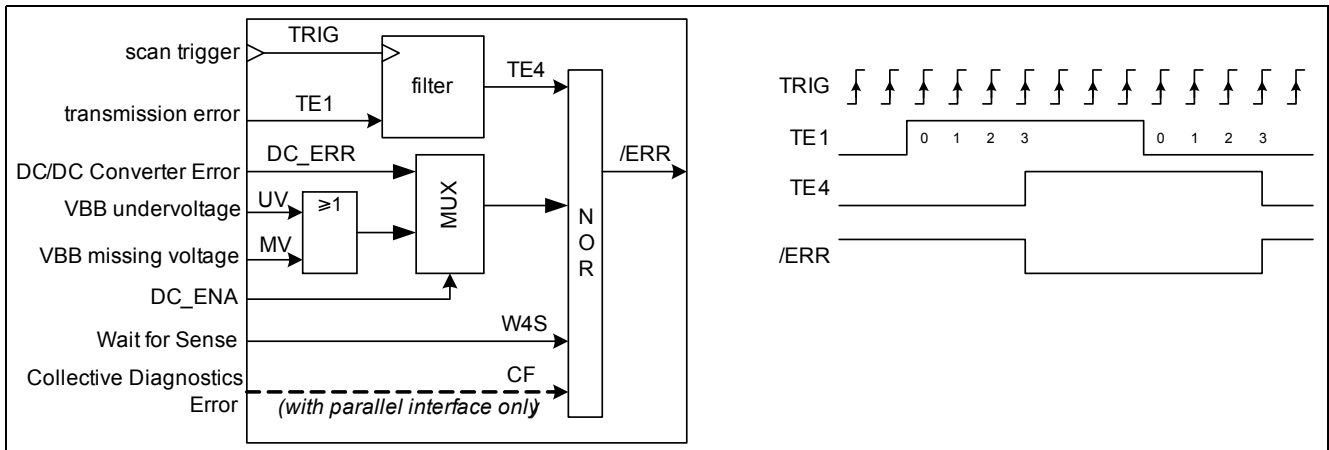

Figure 15 Common Error Output

3.6 Programmable Digital Input Filter

The sensor data and diagnosis bits of each input channel can be filtered by a configurable digital input filter. If selected, the filter changes its output according to an averaging rule with a selectable average length. When the sensor state changes without any spikes and noise the change is delayed by the averaging length. Sensor spikes that are shorter than the averaging length are suppressed. **Figure 16** shows the behaviour of the filter. The clock of the Digital Filter is supplied from the internal oscillator. Therefore the filter time depends on the oscillator frequency setting. For the filtering times of 1.6 msec , 3.2 msec , 10 msec , 20 msec a prescaler was used. Therefore the update interval was chosen to be 4 usec, 8 usec, 64 usec , 64 usec respectively (based on 500 kHz clock).

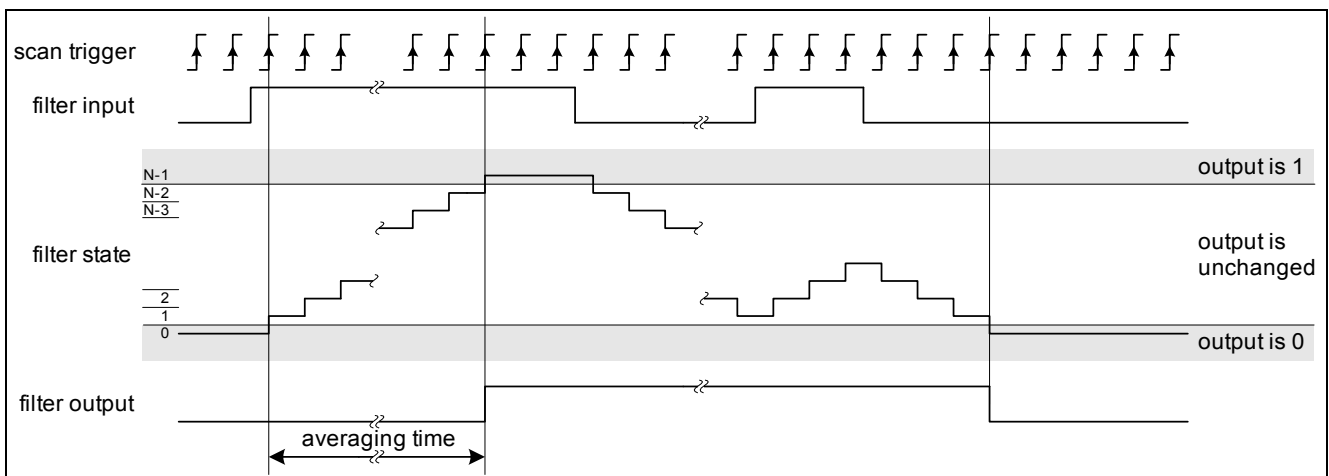

Figure 16 Digital Filter Behavior

The averaging length is selected for each channel individually using the configuration registers **COEFIL0-7**. The programmed filter time apply for both the data and the diagnostics of one channel. See **Table 11** for the different setting options including filter bypass.

Figure 17 and **Table 17** describe the timing for changing filter-coefficients. Especially timing restrictions have to be obeyed implying a minimal processing time until the new configuration and the filtered data are valid and can e.g. be frozen with the pin SYNC. Changing the filter coefficients means resetting always the related filter.

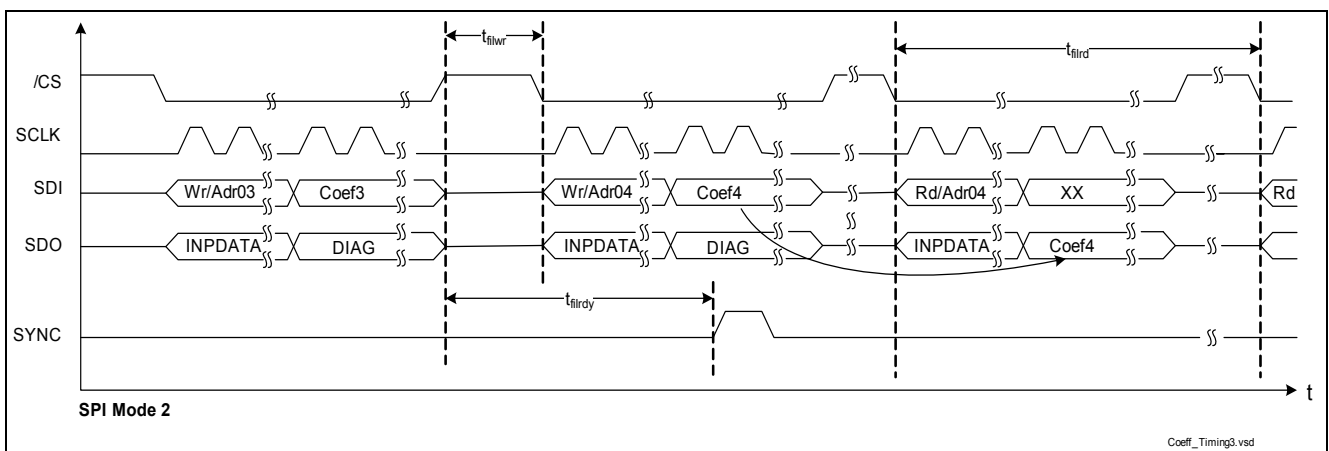

Figure 17 Filter Time Programming and Update Timing

Whereas the absolute filter time depends on the internal oscillator frequency accuracy, the maximal jitter per channel of the IC is 1.5 %. The channel jitter defined in the **Figure 18** is due to the sampling error of the sensor data with the internal clock and applies equally for all the channels.

Functional Description

Furthermore, a fixed propagation delay has to be taken into account due to the data transmission over the Coreless Transformer.

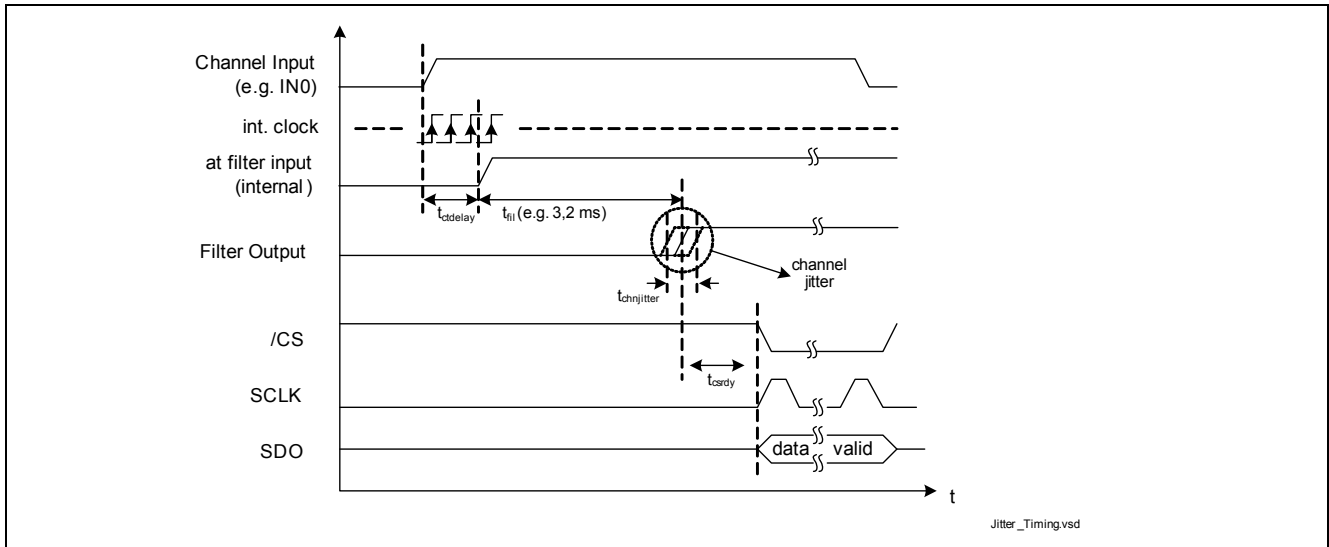

Figure 18 Channel Jitter Definition

Functional Description

3.7 Parallel Interface Mode

The ISO11813T contains a parallel interface that can be selected by pulling the pin SEL to logic Low state. The interface can be directly controlled by the microcontroller output ports. (Figure 19). The output pins AD7:AD0 are in state “Z” as long as $\overline{CS}=1$. Otherwise, new sensor data bits (Input-Value) or diagnosis bits (Status) are driven with the falling edge of \overline{RD} and provided at pins AD7:AD0. Incoming data for a write access are sampled with the rising edge of \overline{WR} .

Although write- and read-commands can be distinguished by the pins \overline{WR} and \overline{RD} additionally the MSB of the address-byte has to be set or not set (analog to the serial access). Write commands are configured with the MSB of the address-byte set to “1”, read commands are configured with the MSB of the address-byte set to “0”.

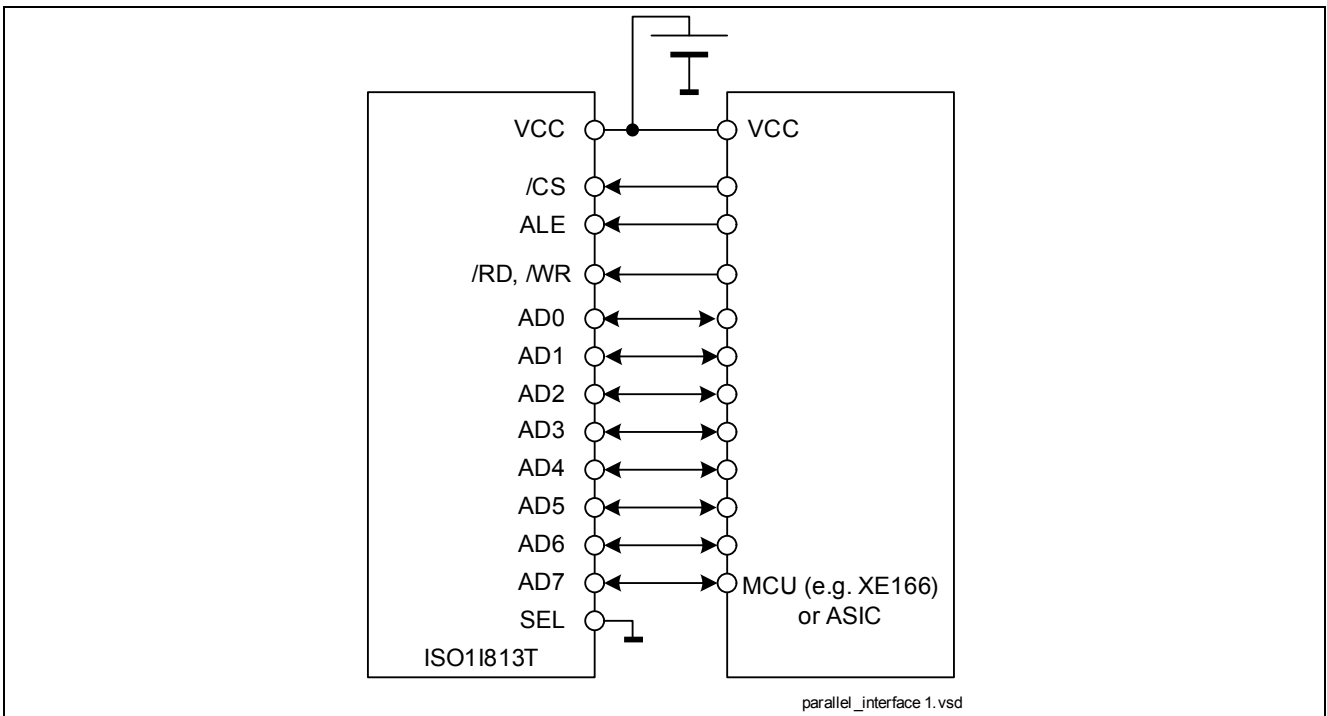

Figure 19 Bus Configuration for Parallel Mode

The timing requirements for the parallel interface are shown in Figure 20, Figure 21 and Table 15.

Functional Description

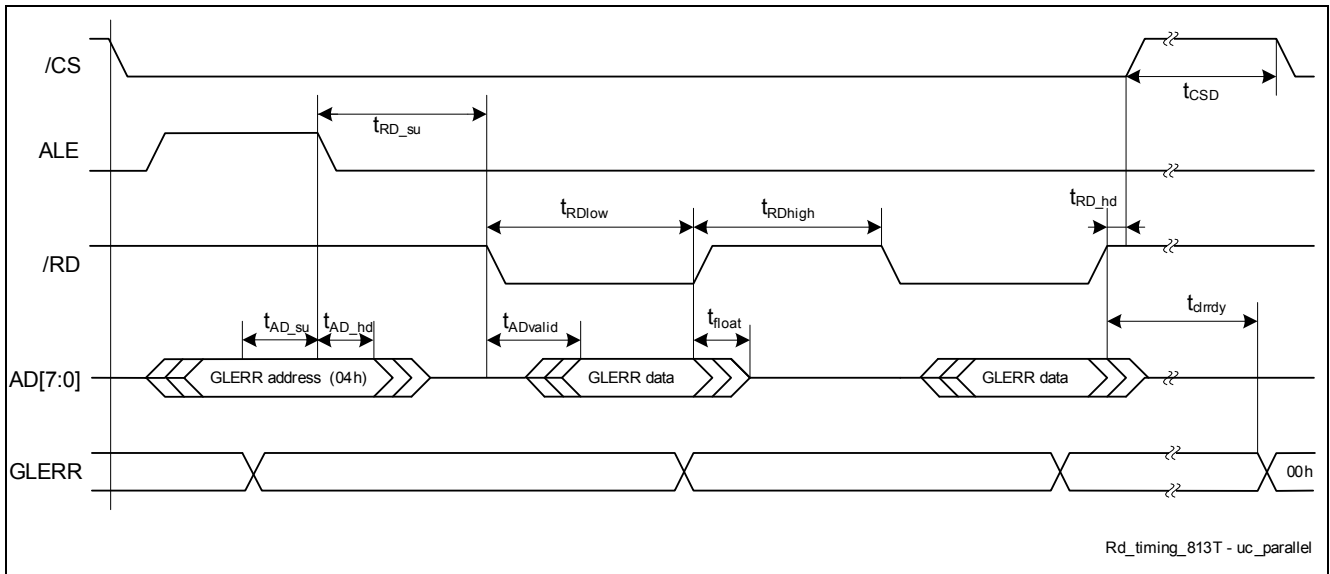

Figure 20 Parallel Bus Timing Read

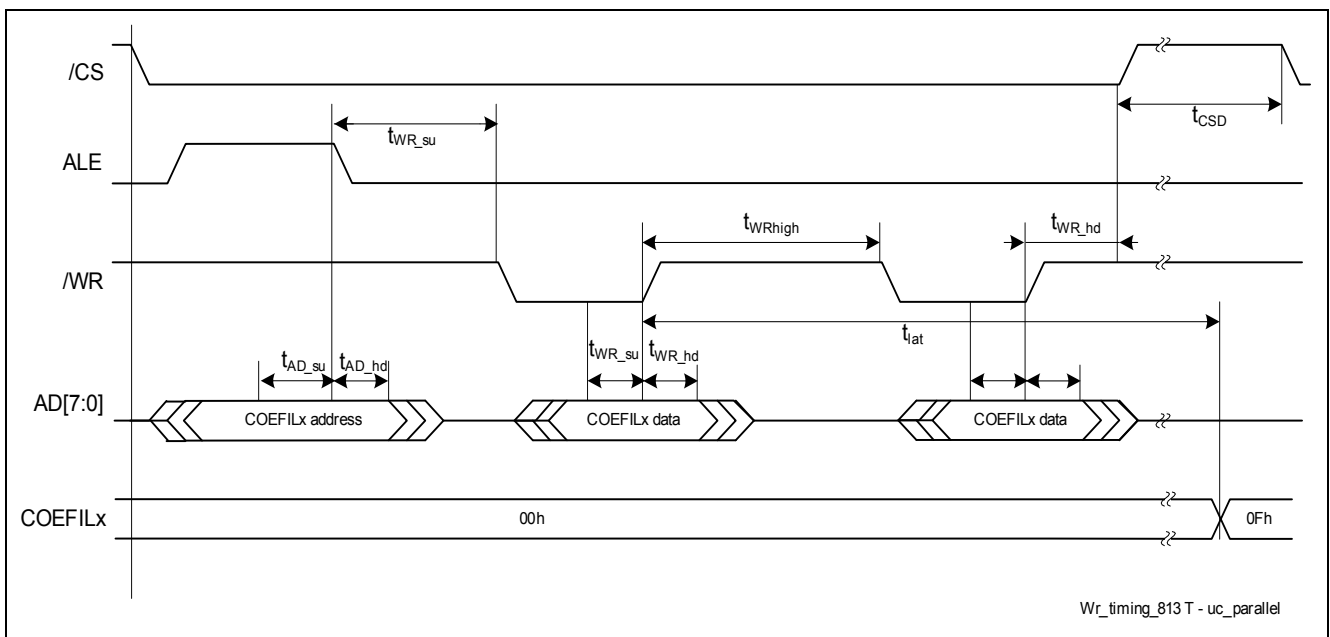

Figure 21 Parallel Bus Timing Write

Functional Description

3.8 Serial Interface Mode

The ISO11813T contains two serial interfaces that can be activated by pulling the pin SEL to logic High state. The interface can be directly controlled by the microcontroller output ports. The output pins SDO and SSO are in state "Z" as long as $\overline{CS}=1$. Otherwise, the bits are sampled with the falling edge of \overline{CS} . With every falling edge of SCLK the bits are provided serially to the pin SDO and SSO respectively. At the same time, the inputs to SDI, SSI are registered into input-FIFO buffers (sampled with the rising edge of SCLK). When all internally sampled bits have been transferred to SDO/SSO, the buffered bits from the inputs SDI/SSI are provided to these pins (daisy-chain support).

The timing requirements for the serial interface are shown in [Figure 22](#) and in [Table 16](#).

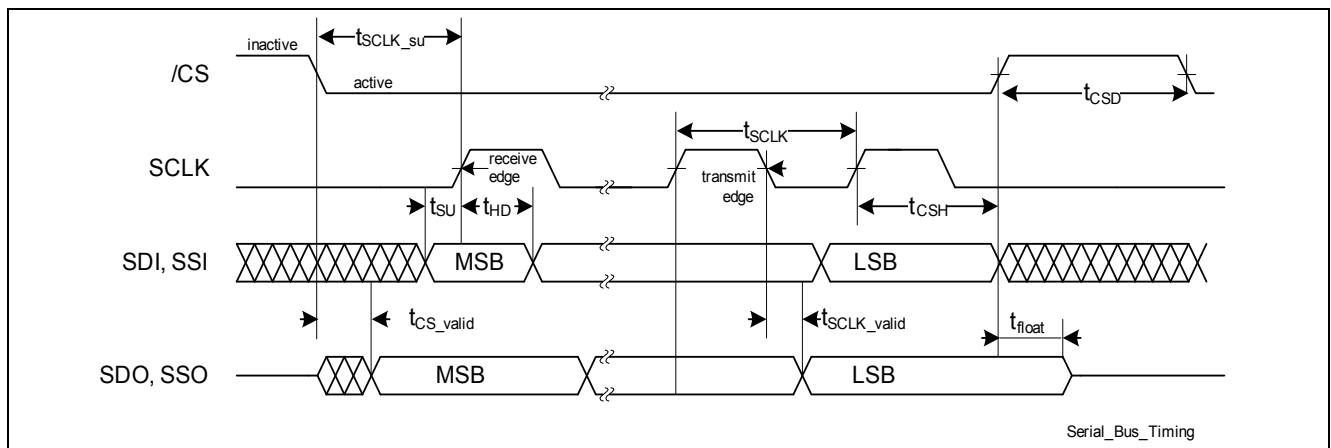

Figure 22 Serial Bus Timing

Several SPI topologies are supported: pure bus topology, daisy-chain and any combinations ([Figure 23](#)). Of course independent individual control with dedicated SPI controller interfaces for each slave IC is possible, as well.

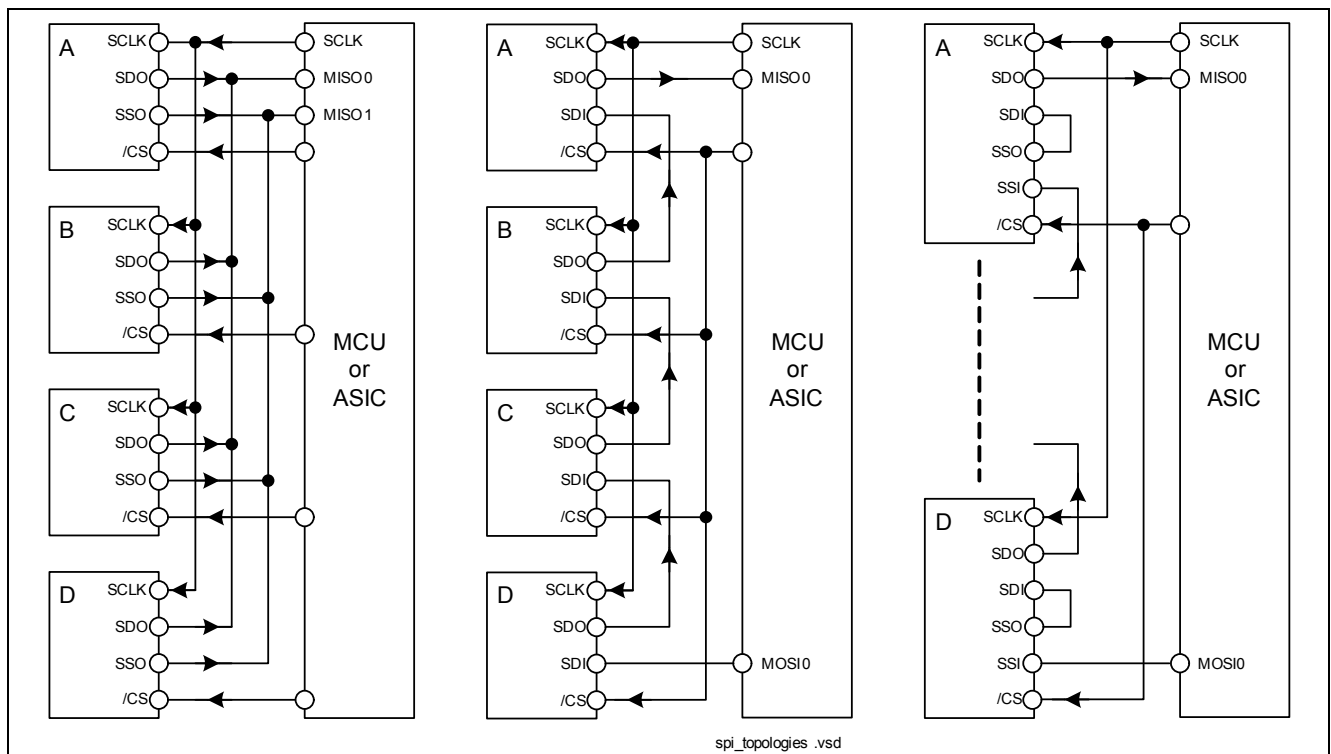

Figure 23 Example SPI Topologies

3.8.1 SPI Modes

The architecture provides 2 independent SPI-interfaces with serial read and serial write options. All register addresses can be accessed independently from both SPI-interfaces with one restriction : a simultaneous serial write on both SPI-interfaces is forbidden. Therefore only one temporary register for storing the write data is provided. All other combinations read (SPI_channel 1) / read (SPI_channel 2) and write (SPI_channel 1) / read (SPI_channel 2) and read (SPI_channel 1) / write (SPI_channel 2) are allowed. There are no restrictions on the selection of register addresses from both channels.

Write commands are configured with the MSB of the address-byte set to "1", read commands are configured with the MSB of the address-byte set to "0".

3.8.1.1 Switching Serial Modes

All serial modes MS1, MS0 = 11, 01, 10, 00 are switchable during operation but not within a serial transfer frame. No internal registers are affected. Only multiplexers and CRC-engines can be activated or deactivated. Internal FSMs are reset. The user has to run one dummy serial process after switching of a serial mode to clear the serial shift registers and reset the internal FSMs. For example: switching from MS1, MS0 = 00 to MS1, MS0 = 11 means the 24 bit serial shift registers and the CRC-engines will be activated. To guarantee proper operation one dummy read sequence has to be processed means "shift in 24 bits with read address, zeros and CRC within a \overline{CS} = Low frame" to operate the serial interface in the new mode. A reliable output is not guaranteed for the first serial process. The same is true for changing the serial mode in the reverse direction : from MS1, MS0 = 11 to MS1, MS0 = 00. Here at least one dummy serial access (8 SCLK-cycles) within a \overline{CS} =Low frame is necessary.

Be aware that in Mode01 read access the data at SDO/SSO corresponds to the address which has been written in the frame before. Mode00 and Mode 01 support the daisy-chain application.

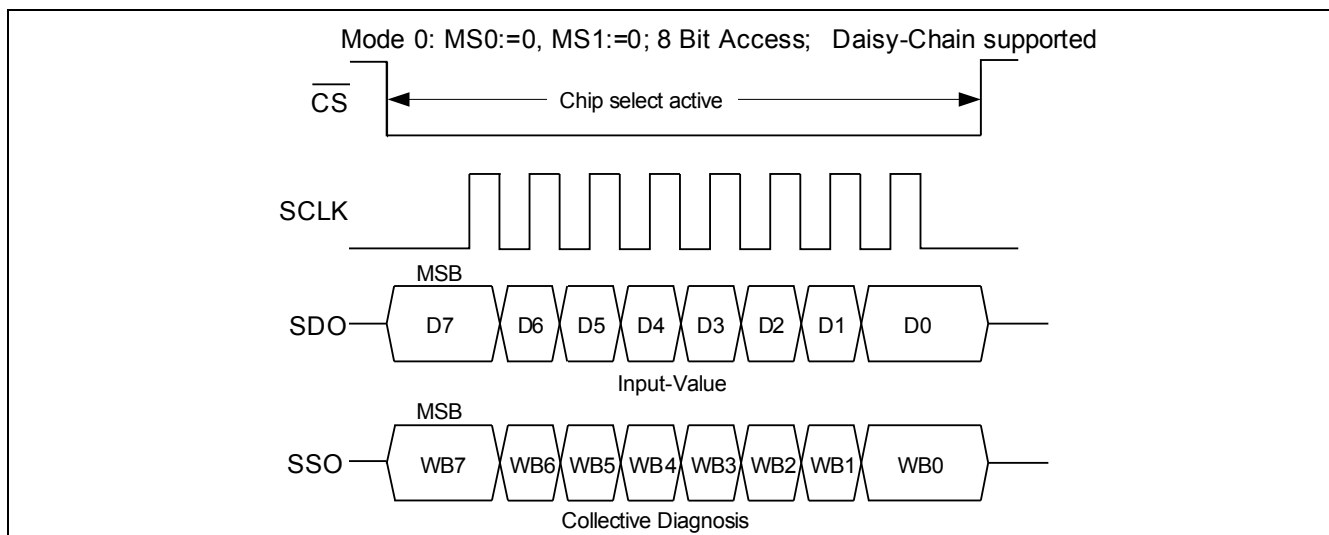

Figure 24 SPI Mode 0

Functional Description

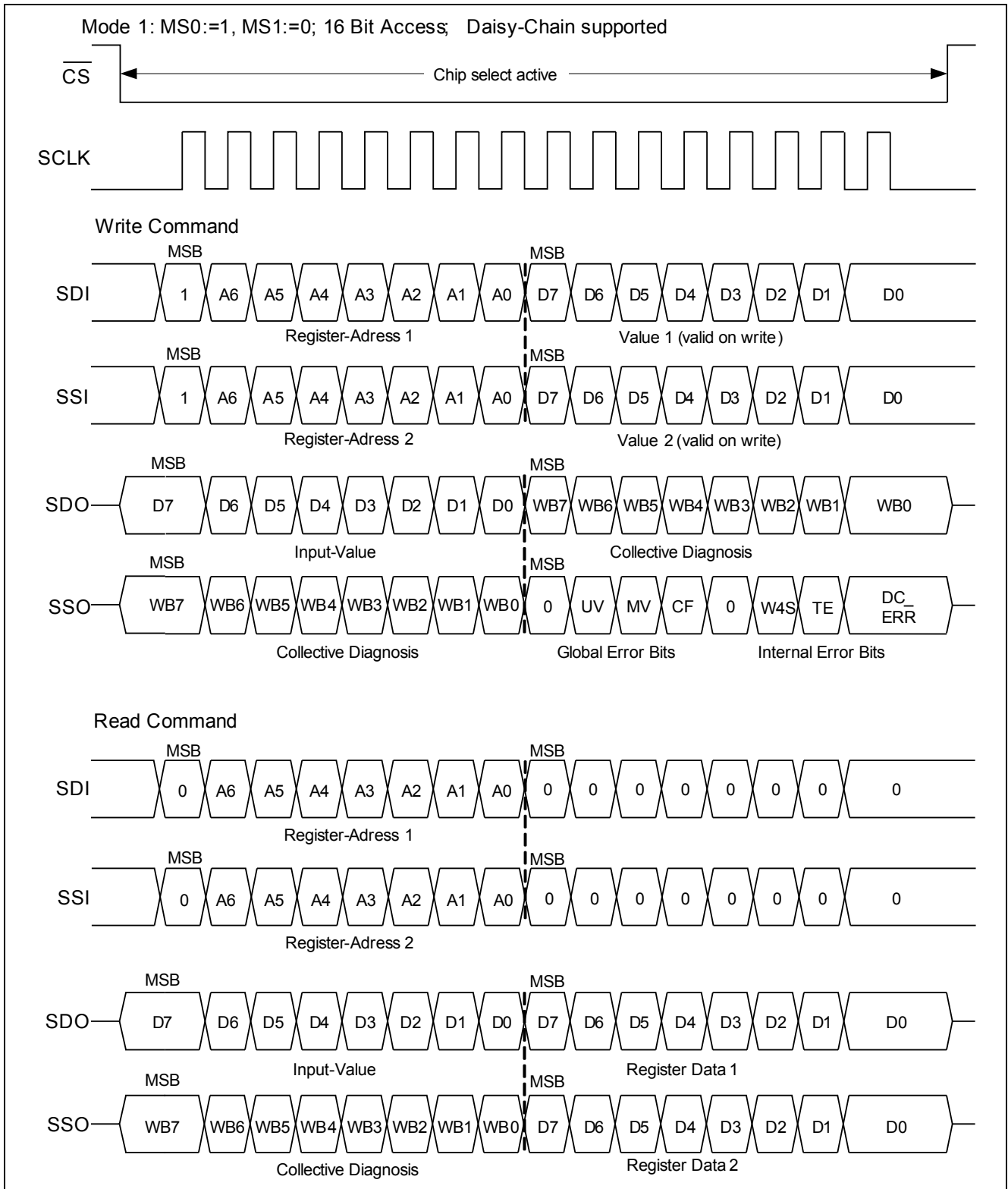

Figure 25 SPI Mode 1

Functional Description

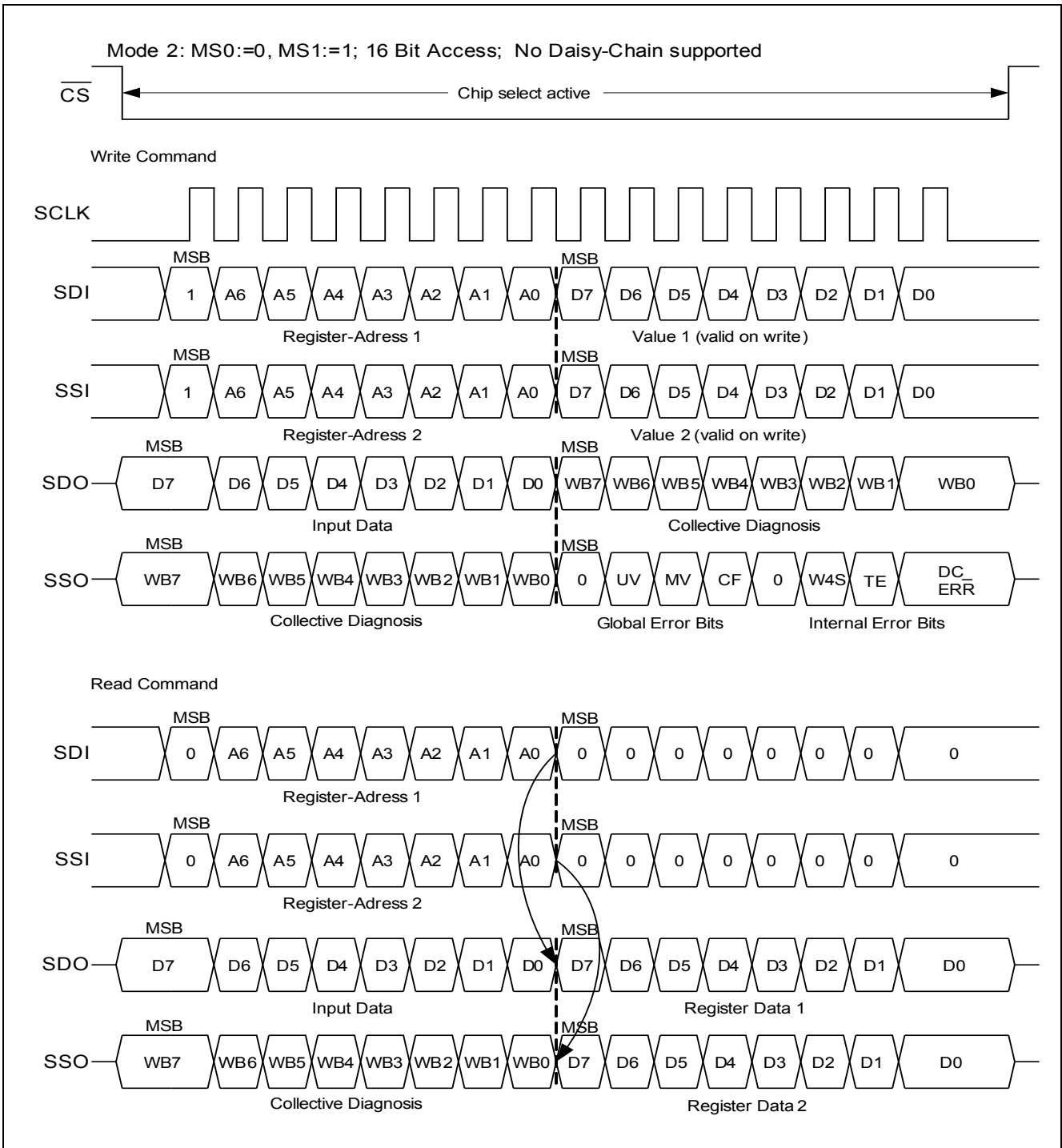

Figure 26 SPI Mode 2

Functional Description

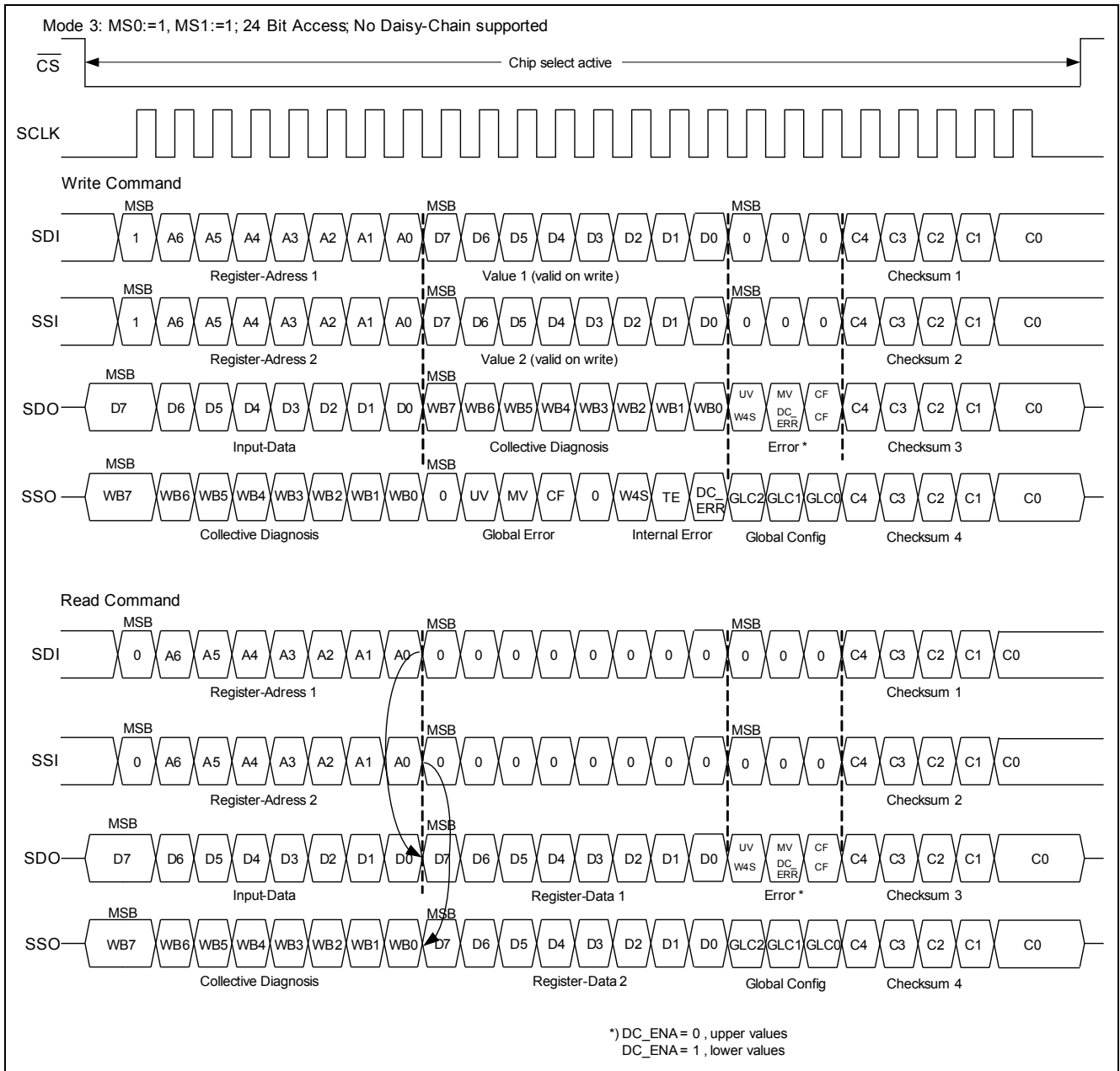

Figure 27 SPI Mode 3

The error values in the SDO-segment depends on the setting of DC_ENA. If DC_ENA is set to '1' the IC is supplied by the integrated DC/DC converter and the error information W4S, DC_ERR, CF is valid. If DC_ENA is set to '0' the error information UV, MV, CF is valid

3.8.2 Architecture of CRC-Engines

For writing serial data into the uC-interface chip one serial-SPI-mode (MS1, MS0 = 11) delivers with the pure input data bit stream (write by an uC, 19 bits) also the CRC-signature (5 bits). The total bitstream is fed into the CRC-input engines and processed according to the underlying CRC-algorithm serially.

The CRC is a 5-Bit-checksum and will be calculated with the polynom $X^5 + X^4 + X^2 + 1$ and is calculated from Bit [23:5]. The checksum is transferred to Bit [4:0]. After totally processed 24 serially shifted in-bits (including the CRC-signature) the total result of the CRC-algorithm processing has to be zero. In the case of another result different from zero the delivered signature is not consistent with the delivered bit stream. This will be indicated by setting the CRC_ERR Pin to Low.

For reading of registers by a uC a CRC-signature (5 bits) (MS1, MS0 = 11) will be delivered with the pure data bit stream (19 bits) : data output (read by a uC). The read bitstream has to be processed according to the CRC-algorithm serially. After totally processed 19 serially shifted out-bits the CRC-signature has been calculated and delivered to the output pins SDO, SSO.

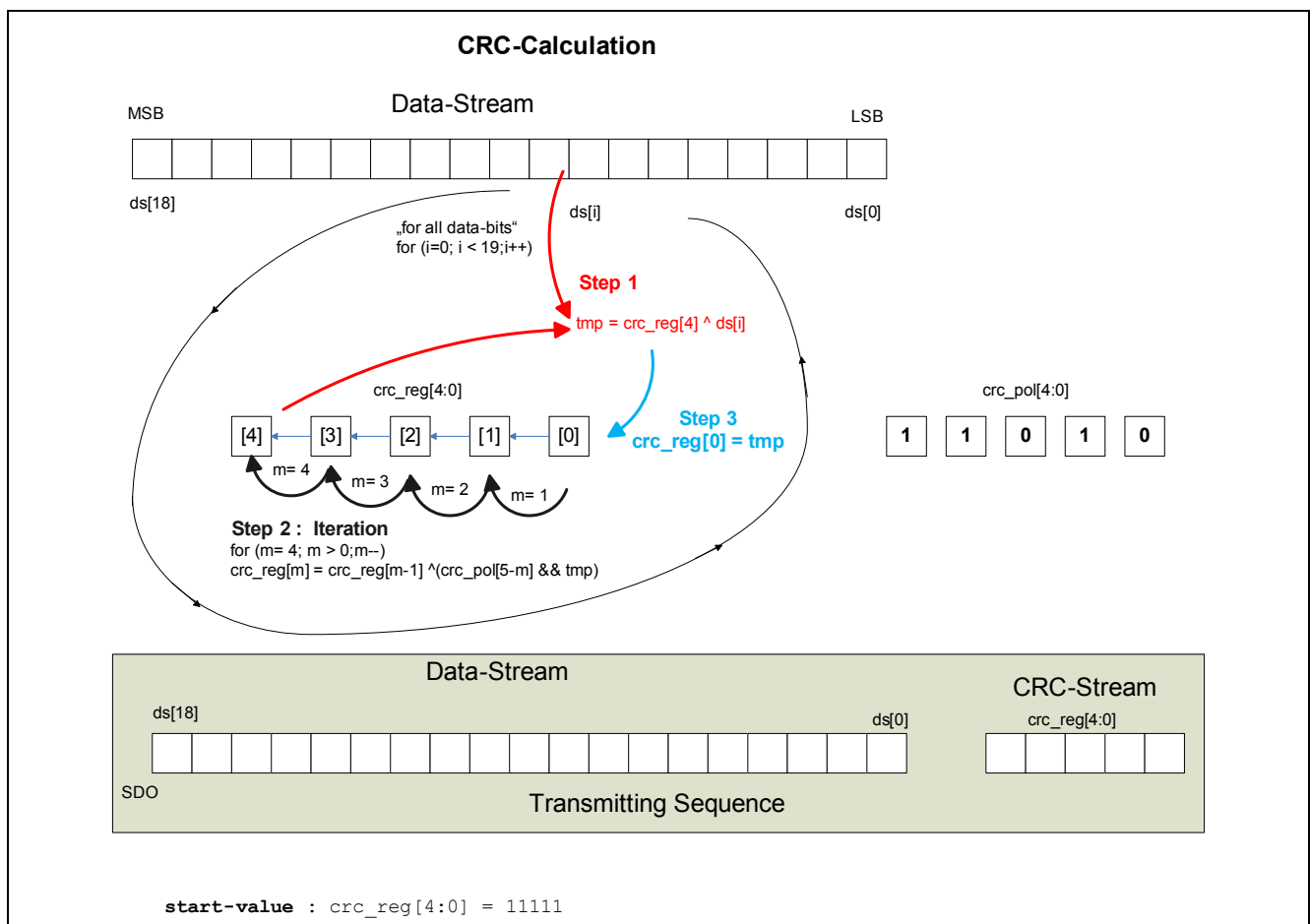

Figure 28 CRC-Calculation

3.9 SYNC Operation

In automation systems there is sometimes the need to actualize the input-signal/collective diagnostics at the same time system-wide. Therefore a signal SYNC is needed to latch the input-signals/collective diagnostics at the given time, otherwise the input-signals/collective diagnostics have to be actualized continuously with the system clock clk_500k.

The filtered data and diagnostics can be synchronized on the falling edge of the SYNC pin or “frozen” by holding SYNC Low (see [Figure 29](#) and [Table 17](#)).

The filtered input data will be latched in the input-value-register and the filtered wire-break diagnosis (inclusive CF-bit) will be latched into the collective diagnosis register every data-cycle when the SYNC-signal is in high state or with the falling edge of SYNC. When the SYNC-signal is in low state the input-data-register and the collective diagnosis register won't be updated any longer. In the same way the SYNC-signal actualizes the information of the global and internal error register.

The SYNC-signal doesnot affect the operation of the internal filtering-structures.

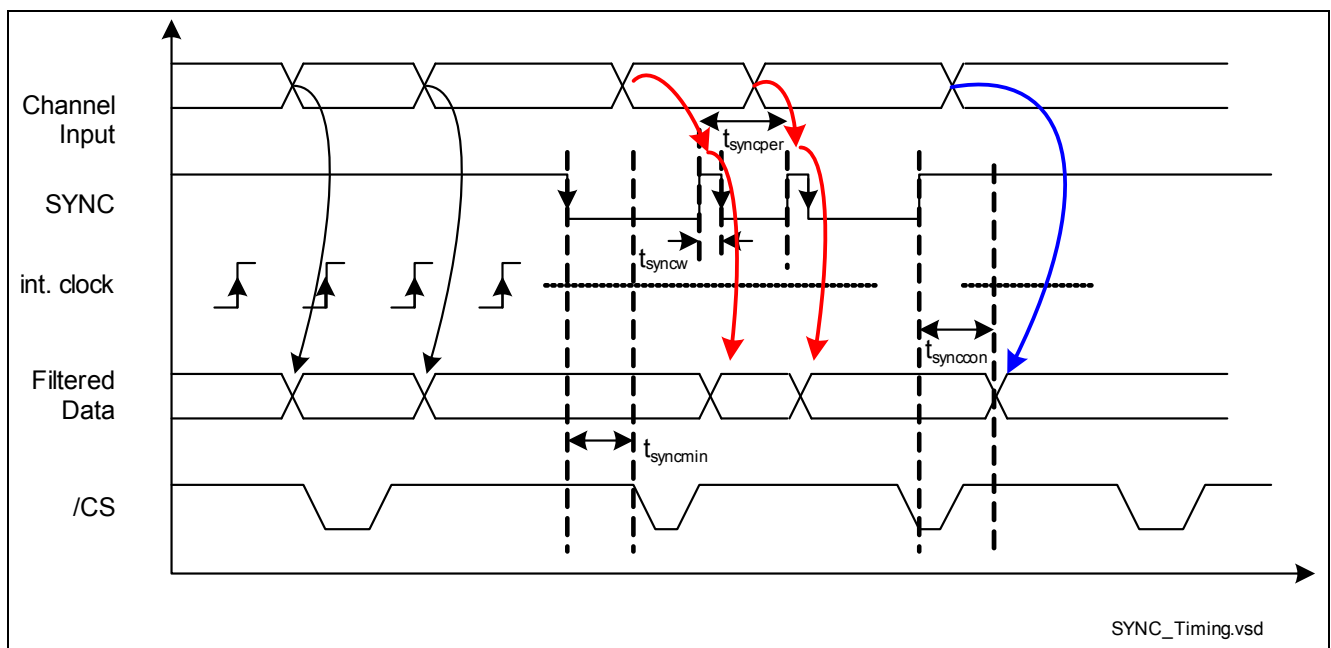
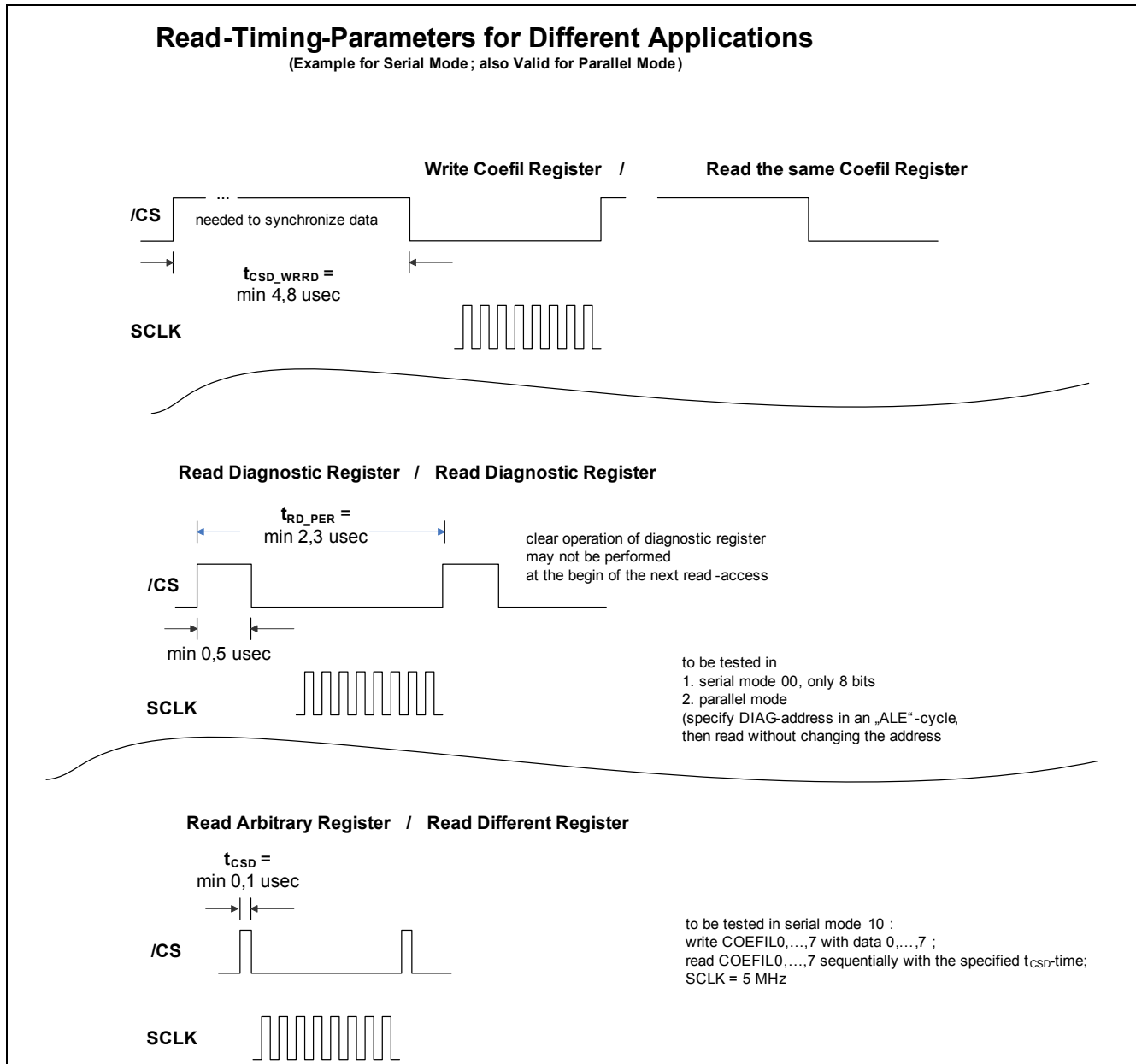

Figure 29 SYNC Operation Timing

Functional Description

3.10 Write-Read- Access and Read-Read-Access for Different Applications

Depending on the application different timing requirements on the \overline{CS} -idle cycle ($\overline{CS} = \text{high}$) or on the \overline{CS} -period have to be obeyed (**Figure 30**). The parameters are specified in the electrical requirements. The verification of the parameter t_{RD_PER} is performed in the way that a wirebreak signal for 4 usec is generated, after the propagation delay over the sense chip and the CT the corresponding DIAG-bit (plus an uncertainty of ± 1 cycle ($f_{scantyp}$)) has to be detected. After reading the DIAG-register it has to be assured that the DIAG-register has been cleared (after about 2 cycles with an uncertainty of ± 1 cycle ($f_{scantyp}$)).

Figure 30 Critical Timing Parameters for Write-Read-Access or Read-Read-Access

4 Standard Compliance

The ISO11813T allows the design of a sensor interface compliant with the standard requirements listed below:

System Insulation Characteristics as shown in [Table 3](#),

System Immunity Characteristics as shown in [Table 5](#).

These requirements are valid for an application using the ISO11813T including external circuitry (as proposed in [Figure 31](#)), not for the IC alone.

Note: When the IC is not supplied, probing of the digital input interface is still possible due to the external circuitry, i.e. the 12k resistor and the LED. In addition to the current through the LED a small current I_{IxH} flows through the pins IxH and IxL.

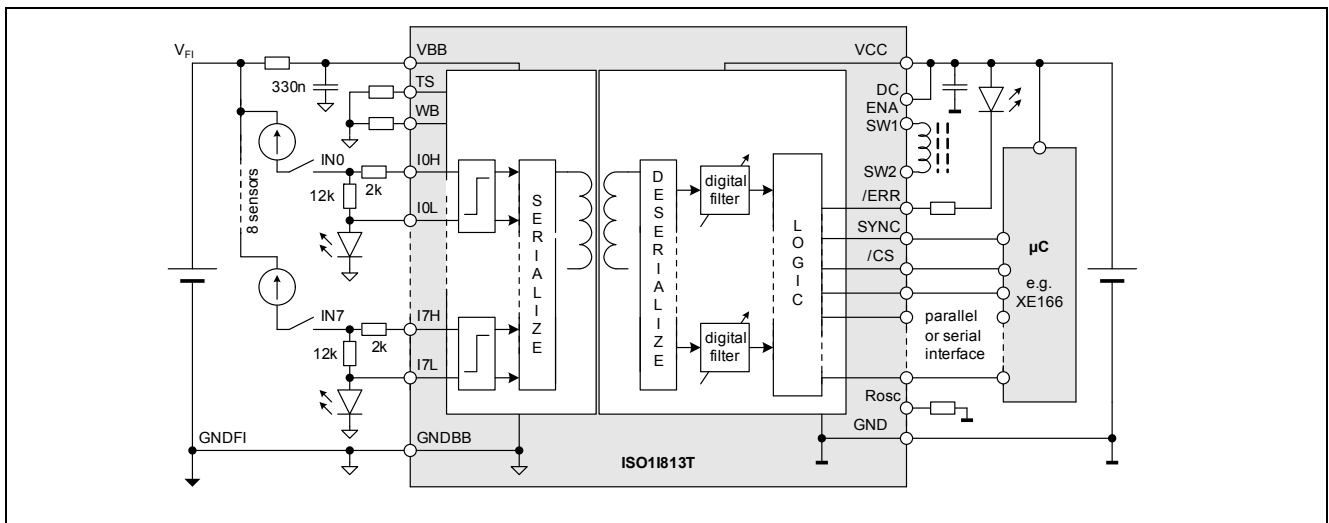

Figure 31 Recommended Application Circuit

Table 2 System Absolute Maximum Ratings

Parameter	Symbol	Values			Unit	Note / Test Condition
		Min.	Typ.	Max.		
Field Input Voltage Overvoltage 1300 ms	V_{Flov}	-45		+45	V	
Input Voltage INx	V_{INx}	-45		+45	V	

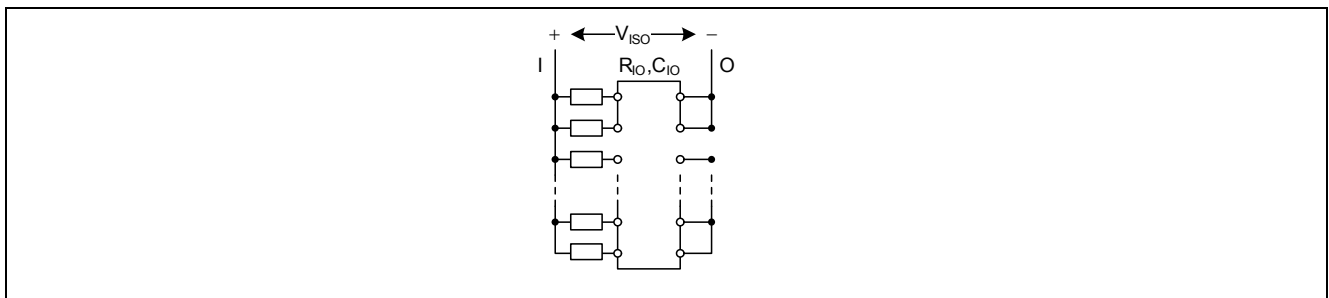

Figure 32 System Insulation Characteristics

Standard Compliance

Table 3 System Insulation Characteristics

Parameter	Symbol	Values			Unit	Note / Test Condition
		Min.	Typ.	Max.		
Pollution Degree (DIN VDE 0110/1.89, DIN EN 60664-1)			2			
Minimum External Clearance	CLR	6.7			mm	
Minimum External Creepage	CPG	6.2			mm	
Maximum Working Insulation Voltage	V _{ISO}	500			V _{AC}	1 min duration ¹⁾

1) not subject to production test, verified by characterization

Approvals:

UL1577

Certificate Number 20120309-E311313

5 Electrical Characteristics

This section comprises:

- Operating Conditions and Power Supply (see [Chapter 5.2](#))
- Electrical Characteristics Input Side (see [Chapter 5.3](#))
- Electrical Characteristics Microcontroller Interface (see [Chapter 5.4](#))

Tolerance values always contain the sum of process-related tolerance values and tolerance-values based on the temperature drift within the specified temperature range.

5.1 Absolute Maximum Ratings

All voltages at pins 25 to 48 are measured with respect to ground GNDBB. All voltages at pins 1 to 24 are measured with respect to GND. The voltage levels are valid if other ratings are not violated. The two voltage domains VCC, GND and VBB, GNDBB are internally electrically isolated.

Stresses above those listed under “Absolute Maximum Ratings” may cause permanent damage to the device. This is a stress rating only and functional operation of the device at these or any other conditions above those indicated in the operational sections of this specification is not implied. Exposure to absolute maximum rating conditions for extended periods may affect device reliability.

Table 4 Absolute Maximum Ratings

Parameter	Symbol	Value		Unit	Note / Test Condition
		Min.	Max.		
Continuous Voltage at pin VBB	V_{VBB}	-0.3	45	V	Power Dissipation must not exceed max-value
Peak Voltage VBB, Overvoltage 500 ms	V_{VBB}	-0.3	45	V	
Supply Voltage VCC	V_{VCC}	-0.3	6.5	V	
Continuous Voltage at logic pins 1 - 24 (except VCC and GND pins)	V_{LOG}	-0.3	6.5	V	
Continuous Voltage at pin TS, WB		-0.3	6.5	V	
Junction Temperature	T_J	-40	150	°C	
Storage Temperature	T_S	-50	150	°C	
Power Dissipation	P_{tot}		800	mW	
Input Voltage Range	V_{IxH}	-45	45	V	
Input Voltage Range	V_{IxL}	-0.3	5	V	
Error Pin Sink Current ($\overline{ERR}=0$)	$I_{ERRsink}$		5	mA	$V_{ERR} < 0.25 \cdot V_{VCC}$
Error Pin Sink Current ($\overline{CRCERR}=0$)	$I_{CRCsink}$		5	mA	$V_{ERR} < 0.25 \cdot V_{VCC}$
DC-DC switch outputs 1/2	SW1/2		20	V	
Electrostatic discharge voltage (Human Body Model) according to JESD22-A114-B	V_{ESD}	–	–	2.5	kV
Electrostatic discharge voltage (Charge Device Model) according to ESD STM5.3.1 - 1999	V_{ESD}	–	–	1.5	kV

Electrical Characteristics

5.2 Operating Conditions and Power Supply

For proper operation of the device, absolute maximum rating ([Chapter 5.1](#)) and the parameter ranges in [Table 5](#) must not be violated. Exceeding the limits of operating condition parameters may result in device malfunction or spec violations. The power supply pins VBB and VCC have the characteristics given in [Table 7](#).

Table 5 Operating Range

Parameter at $T_j = -40 \dots 125^\circ\text{C}$	Symbol	Value		Unit	Note / Test Condition
		Min.	Max.		
Supply Voltage Logic VCC	V_{VCC}	2.85	5.5	V	related to GND
Supply Voltage Senses VBB	V_{VBB}	9.6	35	V	related to GNDBB
Continuous VBB Voltage in Self-Power Mode	V_{VBBDC}	12	16	V	see Figure 5 and Table 8 for operation points ¹⁾
Ambient Temperature	T_A	-40	85	$^\circ\text{C}$	
Junction Temperature	T_J	-40	125	$^\circ\text{C}$	
Common Mode Transient	dV_{ISO}/dt	-25	25	$\text{kV}/\mu\text{s}$	
Magnetic Field Immunity	$ H_{IM} $	30		A/m	IEC61000-4-8

1) recommended for operation

Table 6 Thermal Characteristics

Parameter at $T_j = -40 \dots 125^\circ\text{C}$, $V_{bb}=9.6\dots35\text{V}$, $V_{CC}=2.85\dots5.5\text{V}$, unless otherwise specified	Symbol	Limit Values		Unit	Note / Test Condition
		Min.	Max.		
Thermal resistance junction - case top	R_{thJC_Top}		15.0.	K/W	measured on top side ¹⁾
Thermal resistance junction - case bottom	R_{thJC_Bot}		13.8.	K/W	¹⁾
Thermal resistance junction - pin	R_{thJP}		11.8	K/W	¹⁾
Thermal resistance @ 2 cm ² cooling area ²⁾ (thermal conductance only by radiation and free convection)	$R_{th(JA)}$		88.6	K/W	¹⁾

1) not subject to production test, specified by design

2) Device on 50 mm x 50 mm x 1.5 mm epoxy PCB FR4 with 2 cm² (one layer, 35 μm thick) copper area. PCB is vertical without blow air.

Table 7 Electrical Characteristics of the Power Supply Pins

Parameter at $T_j = -40 \dots 125^\circ\text{C}$, $V_{bb}=9.6\dots35\text{V}$, $V_{CC}=2.85\dots5.5\text{V}$, unless otherwise specified	Symbol	Values			Unit	Note / Test Condition
		Min.	Typ.	Max.		
VBB UVLO startup threshold	V_{VBBon}			9.6	V	
VBB UVLO shutdown threshold	V_{VBBoff}	8.0			V	¹⁾
VBB UVLO Hysteresis	V_{VBBhys}		1		V	
VBB missing voltage OFF (MV) threshold	$V_{VBBmvoff}$			13.9	V	

Electrical Characteristics

Table 7 Electrical Characteristics of the Power Supply Pins (cont'd)

Parameter at $T_j = -40 \dots 125^\circ\text{C}$, $V_{bb}=9.6\dots 35\text{V}$, $V_{CC}=2.85\dots 5.5\text{V}$, unless otherwise specified	Symbol	Values			Unit	Note / Test Condition
		Min.	Typ.	Max.		
VBB missing voltage ON (MV) threshold	$V_{VBBm\text{von}}$	12.1			V	
VBB undervoltage OFF (UV) threshold	$V_{VBBu\text{voff}}$			17.0	V	
VBB undervoltage voltage ON (UV) threshold	$V_{VBBu\text{von}}$	15.0			V	
Glitch filters for VBB missing voltage and undervoltage	$T_{VBB\text{fil}}$		8		μs	2)
Undervoltage Current for VBB	$I_{VBBu\text{v}}$		3.5		mA	$V_{VBB} < V_{VBB\text{on}}$
Quiescent Current VBB	I_{VBBq}		5		mA	$V_{VBB} = 24\text{ V}$, $I_{\text{INx}} = 0$, $V_{CC} = 0\text{V}$
Startup Delay (time between VBBon/VCCon and first data output)	$t_{VXX\text{on}}$		26		μs	Digital Filter bypassed ^{2) 3)}
VCC UVLO startup threshold	$V_{VCC\text{on}}$			2.85	V	
VCC UVLO shutdown threshold	$V_{VCC\text{off}}$	2.5			V	4)
VCC UVLO threshold hysteresis	$V_{VCC\text{hys}}$		0.1		V	
Quiescent Current VCC	I_{VCCq}		3.1		mA	$V_{VCC} = 5\text{ V}$ ^{2) 5)} $V_{VBB} = 0\text{V}$
Quiescent Current VCC	I_{VCCq}		2.3		mA	$V_{VCC} = 3.3\text{ V}$ ^{2) 5)} $V_{VBB} = 0\text{V}$

 1) Note that the specified operation of the IC requires V_{VBB} as given in [Table 5](#)

 2) defined for $f_{\text{scantyp}} 500\text{kHz}$

3) not subject to production test, specified by design

 4) Note that the specified operation of the IC requires V_{VCC} as given in [Table 5](#)

5) No Push-Pull Converter connected at SW1/2

Table 8 Self-Powered Supply Operation

Parameter at $T_j = -40 \dots 125^\circ\text{C}$, $V_{bb}=9.6\dots 35\text{V}$, $V_{CC}=2.85\dots 5.5\text{V}$, unless otherwise specified	Symbol	Values			Unit	Note / Test Condition
		Min.	Typ.	Max.		
ON Resistance at SW1/2	R_{DSON}			2.3	Ω	140 mA
Current Rating	I_{SW}			140	mA	
Thermal overload trip temperature	T_{jt}	157		165	$^\circ\text{C}$	1)
Thermal hysteresis	ΔT_{jt}		5		K	1)

1) not subject to production test, specified by design

Electrical Characteristics

5.3 Electrical Characteristics Input Side

The electrical characteristics of the input side (pins 25–48) are given in [Table 9](#). Note that some parameters refer to IN0 to IN7 which are nodes of external circuitry (see [Figure 10](#) or [Figure 31](#)). Electrical characteristics with respect to these nodes are given for the system including the external circuitry and not for the IC alone.

See also [Figure 11](#) for the different threshold parameters.

Table 9 Sensors Inputs

Parameter at $T_j = -40 \dots 125^\circ\text{C}$, $V_{bb} = 9.6 \dots 35\text{V}$, $V_{CC} = 2.85 \dots 5.5\text{V}$, unless otherwise specified	Symbol	Values			Unit	Note / Test Condition
		Min.	Typ.	Max.		
Sink Current Limit at Saturation Edge Type 1/3	$I_{INxsnkC13}$	2.3			mA	$V_{VBB} = V_{VBBon}$, $V_{INx} = 6.7\text{V}$, $V_{IxL} = 1.2\text{V}$
Sink Current Limit at Saturation Edge Type 2	$I_{INxsnkC2}$	3.3			mA	$V_{VBB} = V_{VBBon}$, $V_{INx} = 6.7\text{V}$, $V_{IxL} = 1.2\text{V}$
Sink Current Limit at Maximum Input Voltage Type 1/3	$I_{INxsnkM13}$			3.4	mA	$V_{VBB} = 35\text{V}$, $V_{INx} = 30\text{V}$, $V_{IxL} = 2.5\text{V}$
Sink Current Limit at Maximum Input Voltage Type 2	$I_{INxsnkM2}$			4.8	mA	$V_{VBB} = 35\text{V}$, $V_{INx} = 30\text{V}$, $V_{IxL} = 2.5\text{V}$
LED Supply Current at Maximum Input Voltage, Type 1/3	I_{IxLmax}	2.1		3.1	mA	$V_{VBB} = 35\text{V}$, $V_{INx} = 30\text{V}$, $V_{IxL} = 2.5\text{V}$
LED Supply Current at Maximum Input Voltage, Type 2	I_{IxLmax}	3.1		4.5	mA	$V_{VBB} = 35\text{V}$, $V_{INx} = 30\text{V}$, $V_{IxL} = 2.5\text{V}$
LED Supply Current at High Threshold Type 3	I_{IxL3}	1.5		2.5	mA	$V_{VBB} = V_{VBBon}$, $V_{INx} = 11\text{V}$, $V_{IxL} = 2.5\text{V}$
LED Supply Current at High Threshold Type 2	I_{IxL2}	2.3		3.6	mA	$V_{VBB} = V_{VBBon}$, $V_{INx} = 11\text{V}$, $V_{IxL} = 2.5\text{V}$
LED Supply Current at High Threshold Type 1	I_{IxL1}	1.6		2.6	mA	$V_{VBB} = V_{VBBon}$, $V_{INx} = 15\text{V}$, $V_{IxL} = 2.5\text{V}$
LED Voltage recommended	V_{FLED}	1.9		3.0	V	1)
Sense Voltage Switching Threshold, L→H (Type 1)	$V_{INxDset(1)}$			15	V	$V_{VBB} = 24\text{V}$ $V_{IxL} = 2.5\text{V}$ 2)
Sense Voltage Switching Threshold H→L (Type 1)	$V_{INxDclr(1)}$	11			V	$V_{VBB} = 24\text{V}$ $V_{IxL} = 2.5\text{V}$ 2)
Hysteresis H↔L (Type 1)	$V_{INxDhys(1)}$		1		V	
Sense Voltage Switching Threshold L→H (Type 2)	$V_{INxDset(2)}$			11	V	$V_{VBB} = 24\text{V}$ $V_{IxL} = 2.5\text{V}$ 2)
Sense Voltage Switching Threshold H→L (Type 2)	$V_{INxDclr(2)}$	7			V	$V_{VBB} = 24\text{V}$ $V_{IxL} = 2.5\text{V}$ 2)
Hysteresis H↔L (Type 2)	$V_{INxDhys(2)}$		0.65		V	
Sense Voltage Switching Threshold L→H (Type 3)	$V_{INxDset(3)}$			11	V	$V_{VBB} = 24\text{V}$ $V_{IxL} = 2.5\text{V}$ 2)
Sense Voltage Switching Threshold H→L (Type 3)	$V_{INxDclr(3)}$	7			V	$V_{VBB} = 24\text{V}$ $V_{IxL} = 2.5\text{V}$ 2)

Electrical Characteristics

Table 9 Sensors Inputs (cont'd)

Parameter at $T_j = -40 \dots 125^\circ\text{C}$, $V_{bb}=9.6\dots35\text{V}$, $V_{CC}=2.85\dots5.5\text{V}$, unless otherwise specified	Symbol	Values			Unit	Note / Test Condition
		Min.	Typ.	Max.		
Hysteresis H \leftrightarrow L (Type 3)	$V_{INxDhys(3)}$		0.7		V	
Input Sink Current when $V_{VBB}=0$	I_{IxHq}		300		μA	$V_{VBB}=0\text{V}$ $V_{IxH}=30\text{V}$, $I_{xl} = \text{open}$

- 1) not subject to production test, specified by design
- 2) clamped to 2.5V if "logic 1", internally limited if logic "0"

Table 10 Setting at the Configuration Pins (TS, WB)

Parameter at $T_j = -40 \dots 125^\circ\text{C}$, $V_{bb}=9.6\dots35\text{V}$, $V_{CC}=2.85\dots5.5\text{V}$, unless otherwise specified	Symbol	Values			Unit	Note / Test Condition
		Min.	Typ.	Max.		
TS Pull-Down Resistance for Type 1 Selection	R_{TSpd1}		33		Ω	1)
TS Pull-Down Resistance for Type 2 Selection	R_{TSpd2}		33		$\text{k}\Omega$	1) 2)
TS Pull-Down Resistance for Type 3 Selection	R_{TSpd3}		330		$\text{k}\Omega$	1)
WB pin source current	$I_{WBsource}$		12.5		μA	$R_{WB} = 40\text{k}\Omega$
WB pin detection current	I_{WB}		80		μA	$R_{WB} = 40\text{k}\Omega$
Wirebreak detection blanking time	t_{WB_blank}		1		μs	3) 4)
Type selection blanking time	t_{TS_blank}		2		μs	3) 4)
Max. WB Pin Load Capacitance	C_{WBmax}			5	pF	1)
Max. TS Pin Load Capacitance	C_{TSmax}			20	pF	1)

- 1) required for operation
- 2) Only 4 channels can be used for this case.
- 3) not subject to production test, specified by design
- 4) defined for $f_{scantyp} 500\text{kHz}$

Electrical Characteristics

5.4 Electrical Characteristics Microcontroller Interface

 For the Parallel Mode see [Table 11](#), [Table 12](#), [Table 14](#) and [Table 15](#),

 For the Serial Mode see [Table 11](#), [Table 12](#), [Table 14](#) and [Table 16](#).

 Timing characteristics refer to $C_L < 50$ pF and $R_L > 10$ k Ω .

Table 11 Sensor Scanning and Averaging ¹⁾

Parameter at $T_j = -40 \dots 125^\circ\text{C}$, $V_{bb} = 9.6 \dots 35\text{V}$, $V_{CC} = 2.85 \dots 5.5\text{V}$, unless otherwise specified	Symbol	Values			Unit	Note / Test Condition
		Min.	Typ.	Max.		
Typical Scan Frequency	f_{scantyp}	440		510	kHz	$R_{\text{OSC}} = 22.1$ k Ω without tolerance
Scan Frequency Range	f_{scanrge}	50		500	kHz	²⁾ refer to Figure 8
Input Scan Propagation Delay	t_{ctdelay}		8		μs	¹⁾ applies equally to all channels
Filter Bypass delay	t_{bypass}		2		μs	¹⁾
Minimal Filter Output valid time (until Readout i.e. $\overline{\text{CS}}$ falling edge)	t_{csrdy}		1.2		μs	including maximum channel jitter ¹⁾
Channel Jitter ³⁾	$t_{\text{chnjitter}}$	0		2	μs	for t_{FILTO0} and t_{FILTO1} ¹⁾
Channel Jitter	$t_{\text{chnjitter}}$	0		1.5	%	for t_{FILTO2} to t_{FILTO7} ¹⁾
Default Digital Filter Monitoring Time	t_{FILTdef}		4		μs	bypass ¹⁾
Digital Filter Monitoring Time	t_{FILTO0}		0.050		ms	FT=00 _H ¹⁾
Digital Filter Monitoring Time	t_{FILTO1}		0.100		ms	FT=01 _H ¹⁾
Digital Filter Monitoring Time	t_{FILTO2}		0.400		ms	FT=02 _H ¹⁾
Digital Filter Monitoring Time	t_{FILTO3}		0.800		ms	FT=03 _H ¹⁾
Digital Filter Monitoring Time	t_{FILTO4}		1.600		ms	FT=04 _H , prescaler used ¹⁾
Digital Filter Monitoring Time	t_{FILTO5}		3.200		ms	FT=05 _H , prescaler used ¹⁾
Digital Filter Monitoring Time	t_{FILTO6}		10.000		ms	FT=06 _H , prescaler used ¹⁾
Digital Filter Monitoring Time	t_{FILTO7}		20.000		ms	FT=07 _H , prescaler used ¹⁾
Digital Filter Monitoring Time	t_{FILTOff}		4.0		μs	FT=08 _H .0F _H ¹⁾

 1) valid for $f_{\text{scantyp}} = 500\text{kHz}$

2) not subject to production test, specified by design

 3) the channel jitter is defined in [Figure 18](#)

Electrical Characteristics

Table 12 Setting at the Configuration Pin (Rosc) see also Figure 8

Parameter at $T_j = -40 \dots 125^\circ\text{C}$, $V_{bb}=9.6\dots 35\text{V}$, $V_{CC}=2.85\dots 5.5\text{V}$, unless otherwise specified	Symbol	Values			Unit	Note / Test Condition
		Min.	Typ.	Max.		
Rosc Pin Source Current	I_{Roscsrc}		50		μA	$R_{\text{OSC}} = 22.1 \text{ k}\Omega$
Rosc Resistance to GND	R_{Rosc}	18.4	22.1	221	$\text{k}\Omega$	E96 resistor
Rosc Pin Regulated Voltage	V_{Roscreg}		1.2		V	
Max. Rosc Pin Load Capacitance	C_{Roscmx}			5	pF	1)

1) required for operation

Table 13 Error Pins ($\overline{\text{ERR}}$, $\overline{\text{CRCERR}}$)

Parameter at $T_j = -40 \dots 125^\circ\text{C}$, $V_{bb}=9.6\dots 35\text{V}$, $V_{CC}=2.85\dots 5.5\text{V}$, unless otherwise specified	Symbol	Values			Unit	Note / Test Condition
		Min.	Typ.	Max.		
Error Pin Pull-Up Resistance ($\overline{\text{ERR}}=1$)	R_{ERRpu}		50		$\text{k}\Omega$	
Maximum Switching Frequency ($\overline{\text{ERR}}$, $\overline{\text{CRCERR}}$)	f_{SW}	10		500	kHz	1)
Error Pin Low voltage	V_{ERROL}			$0.25 \cdot V_{\text{VC}}$ C	V	$I_{\text{ERROL}} = 5\text{mA}$

1) not subject to production test, specified by design

Table 14 Logical Pins ($\overline{\text{RD}}$, $\overline{\text{WR}}$, $\overline{\text{ALE}}$, $\overline{\text{MS0/1}}$, $\overline{\text{CS}}$, $\overline{\text{AD7:AD0}}$, $\overline{\text{SCLK}}$, $\overline{\text{SDO}}$, $\overline{\text{SSO}}$, $\overline{\text{SDI}}$, $\overline{\text{SSI}}$, $\overline{\text{SEL}}$)

Parameter at $T_j = -40 \dots 125^\circ\text{C}$, $V_{bb}=9.6\dots 35\text{V}$, $V_{CC}=2.85\dots 5.5\text{V}$, unless otherwise specified	Symbol	Values			Unit	Note / Test Condition
		Min.	Typ.	Max.		
Input Voltage High Level	V_{IH}	$0.7 \cdot V_{\text{VCC}}$		$V_{\text{VCC}}+0.3$	V	
Input Voltage Low Level	V_{IL}	-0.3		$0.3 \cdot V_{\text{VCC}}$	V	
Input Voltage Hysteresis	V_{Ihys}		100		mV	
Output Voltage High Level	V_{OH}	$0.75 \cdot V_{\text{VCC}}$		$1 \cdot V_{\text{VCC}}$	V	$I_{\text{OH}} = 5\text{mA}$
Output Voltage Low Level	V_{OL}	0		$0.25 \cdot V_{\text{VCC}}$	V	$I_{\text{OL}} = 5\text{mA}$
Output Voltage High Level	V_{OH}		2.75		V	$V_{\text{VCC}} = 2.85 \text{ V}$, $I_{\text{OH}} = 1\text{mA}$ 1)
Output Voltage Low Level	V_{OL}		0.1		V	$V_{\text{VCC}} = 2.85 \text{ V} - 5.5 \text{ V}$, $I_{\text{OL}} = 1\text{mA}$

 1) Typical values over temperature derived with $I_{\text{OH}} = 5 \text{ mA}$ and $I_{\text{OL}} = 5 \text{ mA}$; extrapolated to $I_{\text{OH}} = 1 \text{ mA}$ and $I_{\text{OL}} = 1 \text{ mA}$ according to simulation results, voltage drop scales with a factor of 1/5 with the change of 5 mA to 1 mA, not subject to production test

Electrical Characteristics

Table 15 Parallel Interface

Parameter at $T_j = -40 \dots 125^\circ\text{C}$, $V_{bb} = 9.6 \dots 35\text{V}$, $V_{CC} = 2.85 \dots 5.5\text{V}$, unless otherwise specified	Symbol	Values			Unit	Note / Test Condition
		Min.	Typ.	Max.		
Input Pull Up Resistance (RD, WR, CS)	R_{PU}		50		k Ω	
Input Pull Down Resistance (ALE)	R_{PD}		50		k Ω	
Read Request Frequency	f_{RD}	0.06		5	MHz	repeated read access during $\overline{CS} = 0$
Read Request Period ($1/f_{RD}$)	t_{RD}	200		15000	ns	repeated read access during $\overline{CS} = 0$
\overline{CS} Disable time (\overline{CS} high time between two read accesses on different registers) ¹⁾	t_{CSD}	100			ns	
Read-Period for two read accesses on the same register (especially for DIAG, GLERR, INTERR) ²⁾	t_{RD_PER}	2300			ns	defined for $f_{scantyp}$
\overline{CS} Disable time (\overline{CS} high time between a write access and a read access for reading back the written value)	t_{CSD_WRRD}	4800			ns	defined for $f_{scantyp}$
AD0-7 Output valid by read	$t_{ADvalid}$			55	ns	
/RD setup time	t_{RD_su}	55			ns	
/WR setup time	t_{WR_su}	55			ns	
/RD Low duration	t_{RDlow}	100			ns	
/WR Low duration	t_{WRlow}	100			ns	
/RD hold time	t_{RD_hd}	0	20		ns	
/WR hold time	t_{WR_hd}	0	20		ns	
/WR latency time	t_{lat}	600			ns	
/RD Pad to DIAG, GLERR and INTERR Registers Update (Bits Clearing)	t_{clrrdy}	4		6.2	μs	
AD0-7 Output disable time	t_{float}			80	ns	
AD0-7 Data bus setup time	t_{AD_su}	40			ns	
AD0-7 Data bus hold time	t_{AD_hd}	50			ns	

1) not subject to production test, specified by design, verified on subset of ICs, over temperature and supply voltage, read of COEFIL-registers alternatively (Figure 30)

2) not subject to production test, specified by design, verified on subset of ICs, over temperature and supply voltage, permanent read of DIAG-register with a frequency of 500 kHz, supervision of setting of wirebreak-signal and clearing by read (Figure 30)

Electrical Characteristics

Table 16 Serial Interface

Parameter at $T_j = -40 \dots 125^\circ\text{C}$, $V_{bb} = 9.6 \dots 35\text{V}$, $V_{CC} = 2.85 \dots 5.5\text{V}$, unless otherwise specified	Symbol	Values			Unit	Note / Test Condition
		Min.	Typ.	Max.		
Input Pull Up Resistance ($\overline{\text{CS}}$)	R_{PU}		50		$\text{k}\Omega$	
Input Pull Down Resistance (SCLK, SDI)	R_{PD}		50		$\text{k}\Omega$	
Serial Clock Frequency	f_{SCLK}			5	MHz	
Serial Clock Period ($1/f_{\text{SCLK}}$)	t_{SCLK}	200			ns	
Serial Clock High Period	t_{SCLKH}	100			ns	
Serial Clock Low Period	t_{SCLKL}	100			ns	
Minimum $\overline{\text{CS}}$ Hold time (rising edge of SCLK to rising edge of $\overline{\text{CS}}$)	t_{CSH}	40			ns	
$\overline{\text{CS}}$ Disable time ($\overline{\text{CS}}$ high time between two read accesses on different registers) ¹⁾	t_{CSD}	100			ns	
Read-Period for two read accesses on the same register (especially for DIAG, GLERR, INTERR) ²⁾	$t_{\text{RD_PER}}$	2300			ns	defined for f_{scantyp}
$\overline{\text{CS}}$ Disable time ($\overline{\text{CS}}$ high time between a write access and a read access for reading back the written value)	$t_{\text{CSD_WRRD}}$	4800			ns	defined for f_{scantyp}
Minimum Data setup time (required time SDI to rising edge of SCLK)	t_{SU}	5			ns	
Minimum Data hold time (rising edge of SCLK to SDI)	t_{HD}	15			ns	
Minimum $\overline{\text{CS}}$ to SDO/SSO - Output valid time	$t_{\text{CS_valid}}$	50			ns	
$\overline{\text{CS}}$ falling edge to first rising SCLK edge	$t_{\text{SCLK_su}}$	80			ns	
Minimum SCLK to SDO/SSO - Output valid time	$t_{\text{SCLK_valid}}$			80	ns	
Minimum SDO/SSO - Output disable time	t_{float}			65	ns	
New serial mode activation time (MS0/MS1 change to earliest interface access)	$t_{\text{MS_rdy}}$		4		μs	no $\mu\text{Controller}$ access allowed during the change ³⁾) ⁴⁾

1) not subject to production test, specified by design, verified on subset of ICs, over temperature and supply voltage, read of COEFIL-registers alternatively (Figure 30)

2) not subject to production test, specified by design, verified on subset of ICs, over temperature and supply voltage, permanent read of DIAG-register with a frequency of 500 kHz, supervision of setting of wirebreak-signal and clearing by read (Figure 30)

3) not subject to production test, specified by design

4) valid for $f_{\text{scantyp}} = 500\text{kHz}$

Electrical Characteristics

Table 17 Sync and Coefficient Update Timing

Parameter at $T_j = -40 \dots 125^\circ\text{C}$, $V_{bb} = 9.6 \dots 35\text{V}$, $V_{CC} = 2.85 \dots 5.5\text{V}$, unless otherwise specified	Symbol	Values			Unit	Note / Test Condition
		Min.	Typ.	Max.		
Minimum time interval for μC - Read-Access after falling edge of SYNC-signal	t_{syncmin}		500		ns	
Minimum time interval for switching from sync mode into the continuous mode	t_{synccon}	3			μs	
Minimum width of SYNC-signal	t_{syncw}	200			ns	
SYNC-period	t_{syncper}	500			ns	
Minimal time interval between 2 write cycles for filter time programming	t_{filwr}	4			μs	1)
Minimal time interval between a write cycle and a read back cycle for filter time programming	t_{filrd}	4			μs	1)
Minimal time interval between a filter time write cycle and updated filter data freeze	t_{filrdy}	4			μs	1)

 1) valid for $f_{\text{scantyp}} = 500\text{kHz}$

6 Registers of Microcontroller-Interface-Chip

This chapter describes the μ Controller Chip registers.

Table 6-1 Register Bit Type Definition

Type	Symbol	Description
Read	r	The bit can be read
Read only, updated by hardware	h	The bit is updated by the device itself (for instance: sticky bit)
Write	w	The bit can be written

6.1 μ Controller Chip Registers Overview

The [Table 6-2](#) gives an overview of the μ Controller Chip registers and their address.

Table 6-2 Registers Summary

Short Name	Description	Access Rights ¹⁾	Address A7-A0
DIAG	Collective Diagnostics Register (Wire-Break Detection)	rh	00 _H
INPDATA	Input Data Register (Input Channel Data)	rh	02 _H
GLERR	Global Error Register	rh	04 _H
COEFIL0 (COEFIL0-7)	Filter Time for the Data and the Diagnostics of Channel 0	rw	06 _H , 86 _H
COEFIL1	Filter Time for the Data and the Diagnostics of Channel 1	rw	08 _H , 88 _H
COEFIL2	Filter Time for the Data and the Diagnostics of Channel 2	rw	0A _H , 8A _H
COEFIL3	Filter Time for the Data and the Diagnostics of Channel 3	rw	0C _H , 8C _H
COEFIL4	Filter Time for the Data and the Diagnostics of Channel 4	rw	0E _H , 8E _H
COEFIL5	Filter Time for the Data and the Diagnostics of Channel 5	rw	10 _H , 90 _H
COEFIL6	Filter Time for the Data and the Diagnostics of Channel 6	rw	12 _H , 92 _H
COEFIL7	Filter Time for the Data and the Diagnostics of Channel 7	rw	14 _H , 94 _H
INTERR	Internal Error Register	rh	16 _H
GLCFG	Global Configuration Register	rw	18 _H , 98 _H
	Reserved	n.a.	other

1) r=read-only, rw=read-write (timing restrictions apply), rh=read update by hardware

6.2 Presentation of the Registers

The μ Controller side chip provides several 8-bit registers which can be accessed by the μ Controller over the serial or parallel interface. Since those registers are located in the chip internal clock domain, the access is controlled by an internal arbiter processing the read / write requests as well as the synchronization requirements especially to freeze the internal registers when the isochronous mode is used (pin SYNC).

Some timing requirements apply to guarantee the data consistency provided to the μ Controller (see Electrical Characteristics).

6.2.1 Sensor Registers

The sensor data and status (Wire-Break) detected at the channel inputs IxH/L by the sensor side chip are available in the **INPDATA** and **DIAG** registers respectively. The bits of the **DIAG** register have a sticky property i.e. once a wire-break condition has been detected (after the filter time), the respective bits remain set. A read access resets the sticky bits under the condition, that no wirebreak is detected anymore and no wirebreak information is pending at the filter outputs anymore. In the serial modes, both registers are per default driven out at the SDO/SSO outputs.

6.2.2 Status Registers

The **GLERR** and **INTERR** registers contains the status of the IC. **GLERR** monitors the application relevant parameters: undervoltage (UV), missing voltage (MV) and collective fault (CF) whereas **INTERR** indicates the status of internal signals important for the proper operation of the IC: wait for sense chip (W4S), transmission error (TE) and DC-DC error (DC_ERR) in case of self powered mode. Those registers can be read over the serial or parallel interface especially to identify the fault causing the error pin (ERR) to be pulled down. There are different options to read those registers: either through direct addressing (e.g. parallel mode) or through the telegram mode when the serial interface is selected where the bits are shifted out during the transaction.

The bits of the **GLERR** and **INTERR** registers have a sticky property and remains set as long as they are not cleared by a read access and the fault condition is not detected anymore. The **Table 6-3** presents which bits are cleared depending on the serial mode and the SPI channel. In the case of the parallel interface, the bits cleared are the ones whose address is contained in the internal ALE register. Only the bits having been read can be cleared. Since the bits are frozen when a read access is detected, it is guaranteed that only these bits read over the serial or parallel interface can be cleared: if the status of the bits changes during the transaction, they will not be cleared.

Table 6-3 Clear of the Sticky Bits by Serial Interface

Read / Write	Mode 0		Mode 1		Mode 2		Mode 3	
	Read	Write	Read	Write	Read	Write	Read	Write
SPI channel-0	n.a.		RDREG ¹⁾	DIAG	RDREG ¹⁾	DIAG	RDREG ¹⁾ UV, MV, W4S, DC_ERR ²⁾	DIAG UV, MV, W4S, DC_ERR ²⁾
SPI channel-1	DIAG		DIAG RDREG ¹⁾	DIAG UV, MV, W4S, TE, DC_ERR	DIAG RDREG ¹⁾	DIAG UV, MV, W4S, TE, DC_ERR	DIAG RDREG ¹⁾	DIAG UV, MV, W4S, TE, DC_ERR

1) The bits of register which is being read (Direct addressing)

2) depends on setting of DC_ENA

6.2.3 Configuration Registers

The filter times of each channel can be programmed with the **COEFIL0-7** registers. Since the write access requires some time to update the internal registers, specific timing requirements apply especially between 2 successive programming operations. The **COEFIL0-7** registers define as well if the wire break detection should be masked or not in the **DIAG** register.

Only one of the COEFILx registers can be written at the same time (in serial mode only one SPI channel can be used). It is possible to program a filter time and simultaneously to read out another register e.g. another channel filter time.

Furthermore, the behaviour of the IC can be customized with the **GLCFG** register:

- The ratio of the switching frequency of the DC-DC output stage over the internal clock frequency set at the pin CLKADJ can be changed from 1:1 (default) to 2:1.
- A soft reset can be generated to clear the filter stages and reinitialize the data transmission between Sense side and μ Controller side chips.
- The automatical clearing of the **DIAG** register can be disabled, when the register is read without direct addressing.

6.3 μ Controller Registers Description

6.3.1 Collective Diagnostics Register

This register contains the filtered values of the Wire-Break detection of the channels 0 to 7.

This register can be read by the μ Controller. The WB[x] are set with the occurrence of a wire break at input line x and can only be cleared by a read operation of this register if the wire break is not detected anymore (sticky bits). As soon as one of those bits is set, the CF-bit of the **GLERR** is set as well. The **Chapter 6.2.2** explains the way the sticky bits are cleared.

DIAG

Collective Diagnostics Register

(Address : 00_H)

Reset Value: 00_H

7	6	5	4	3	2	1	0
WB7	WB6	WB5	WB4	WB3	WB2	WB1	WB0

rh

Field	Bits	Type	Description
WB[x]	7-0	rh	Channel Wire-Break Detected This bit indicates if a Wire-Break has been detected at the channel x. 0 _B No wire-break signal detected at channel x. 1 _B A wire-break condition has been detected at channel x.

6.3.2 Input Channel Data Register

This register contains the filtered values of the input data detected at the channels 0 to 7.

This register can be read by the μ Controller.

When the parallel interface is selected, the default address contained in the internal ALE register is the address of this register.

INPDATA

Input Data Register

(Address : 02_H)

Reset Value: 00_H

7	6	5	4	3	2	1	0
D7	D6	D5	D4	D3	D2	D1	D0

rh

Field	Bits	Type	Description
D[x]	7-0	rh	Input Channel Data This bit represents the input data detected at the pins IxH of the channel x depending on the sensor type selected. 0 _B Input Data below the input threshold. 1 _B Input Data above the input threshold.

6.3.3 Global Error Register

This register contains the status of the IC parameters monitored during operation.

This register can only be read by the μ Controller. The CF-bit is the OR-combination of all the bits of the **DIAG** register. The bits of this register are sticky and can only be cleared when the bits are read out and the faults are not detected anymore (refer to [Chapter 6.2.2](#) for more details).

The UV and MV bits are reset to 1 when the VBB voltage is below the UVLO threshold or during transmission error between the sensor side and μ Controller side. The bits of the **GLERR** register are used in the generation of the signal of the error pin ($\overline{\text{ERR}}$) and shifted out in some of the serial modes when the SPI interface is selected.

GLERR

Global Error Register

(Address : 04_H)

Reset Value: 06_H

7	6	5	4	3	2	1	0
0					UV	MV	CF
r					rh		

Field	Bits	Type	Description
CF	0	rh	Channel Fault This bit indicates that at least one wire-break condition has been detected at the channel inputs. 0 _B No wire-break condition has been detected at the channels . 1 _B At least one channel shows a wire-break condition .
MV	1	rh	VBB Missing Voltage This bit indicates if a missing voltage condition has been detected at the VBB pin. 0 _B No missing voltage detected at VBB. 1 _B A missing voltage condition has been detected at VBB.
UV	2	rh	VBB Under Voltage This bit indicates if an undervoltage condition has been detected at the VBB pin. 0 _B No undervoltage detected at VBB. 1 _B An undervoltage has been detected at VBB.
0	[7:3]	r	Reserved returns 0 if read.

6.3.4 Filter Time of Channel 0-7 Register

These registers define the filter time for both the data and diagnostics for each channel IN0-7. The wirebreak bit can additionally be masked in the **DIAG** register. These registers can be modified and read by the μ Controller.

COEFIL0-7

Channel 0-7 Filter Time Register

(Address : 06_H - 14_H for read access, 86_H - 94_H for write access,) Reset Value: 1F_H

7	6	5	4	3	2	1	0
0	0	0	MWB	FT			
	r		rw	rw			

Field	Bits	Type	Description
FT	[3:0]	rw	Filter Time This bit field configures the filter time for averaging the Data and the Wire-Break signals detected at channels IN0-7. 00 _H 50 μ s 01 _H 100 μ s 02 _H 400 μ s 03 _H 800 μ s 04 _H 1,6 ms 05 _H 3,2 ms 06 _H 10 ms 07 _H 20 ms 08 _H - 0F _H bypassed (default)
MWB	4	rw	Mask Wire-Break Detection This bit masks the filtered signal of the Wire-Break detection. 0 _B The wire-break signal is masked and is not visible in the DIAG register. 1 _B The wire-break signal is not masked and appears in the DIAG register. (default).
0	[7:5]	r	Reserved returns 0 if read; should be written with 0.

6.3.5 Internal Error Register

This register contains the status of the internal errors monitored for safe IC operation. The bits are sticky and remain set once the fault condition is detected until a read operation occurs and the faults are resolved. The bits of the **INTERR** register are used in the generation of the signal of the error pin ($\overline{\text{ERR}}$) and shifted out in some of the serial modes when the SPI interface is selected. On power up (UVLO), the bits W4S and TE are preset to High and will have to be cleared by a read access during the startup phase.

INTERR

IC Status Register

 (Address : 16_H)

 Reset Value: 06_H

7	6	5	4	3	2	1	0
0				W4S	TE	DC_ERR	
r				rh			

Field	Bits	Type	Description
DC_ERR	0	rh	DC-DC Converter Error This bit indicates if overload condition has been detected at the SW1 or SW2 switches. 0 _B No overload detected. 1 _B Overload detected.
TE	1	rh	Transmission Error This bit indicates if a transmission error has been detected over the Coreless Transformer between the Sense side chip and the μ Controller side chip. 0 _B No transmission error. 1 _B Transmission error.
W4S	2	rh	Wait for Sense Chip This bit indicates the Sense side chip is correctly supplied and ready for transmission. 0 _B Sense Side is ready. 1 _B Sense Side is not ready because of insufficient supply or long transmission error.
0	[7:3]	r	Reserved returns 0 if read.

6.3.6 Global Configuration Register

This register contains configuration parameters for the sensor type selection as well as the DC-DC driver.

GLCFG

Global Configuration Register

(Address : 18_H for read access, 98_H for write access,)

Reset Value: 00_H

7	6	5	4	3	2	1	0
0		DIAG ACLR	SW_R ST	DCK	0		
r		rw	rw	rw	r		

Field	Bits	Type	Description
0	1:0	rw	Reserved returns 0 if read; should be written with 0.
DCK	2	rw	DC-DC Driver Switching Frequency Ratio This bit indicates the ratio between the sampling clock frequency set at Rosc and the switching frequency of the DC-DC driver (pins SW1/2). 0 _B DC-DC switching frequency is equal to the sampling frequency (1:1) (default). 1 _B DC-DC switching frequency is half to the sampling frequency (2:1).
SW_RST	3	rw	Soft-Reset for the Filtering Stage This bit triggers the reset of the Filter registers 0 _B No Reset 1 _B Reset is generated for the Filter stage
DIAG_ACLR	4	rw	Diagnostics Automatical Clear This bit selects if the DIAG register is automatically cleared after any access to the DIAG register (especially for the second SPI channel at the SSO pin, see Table 6-3). The diagnostics remain in both case sticky. 0 _B Automatical clear after any access to the DIAG register (default) 1 _B Automatical clear disabled
0	[7:5]	r	Reserved returns 0 if read; should be written with 0.

7 Package Outline

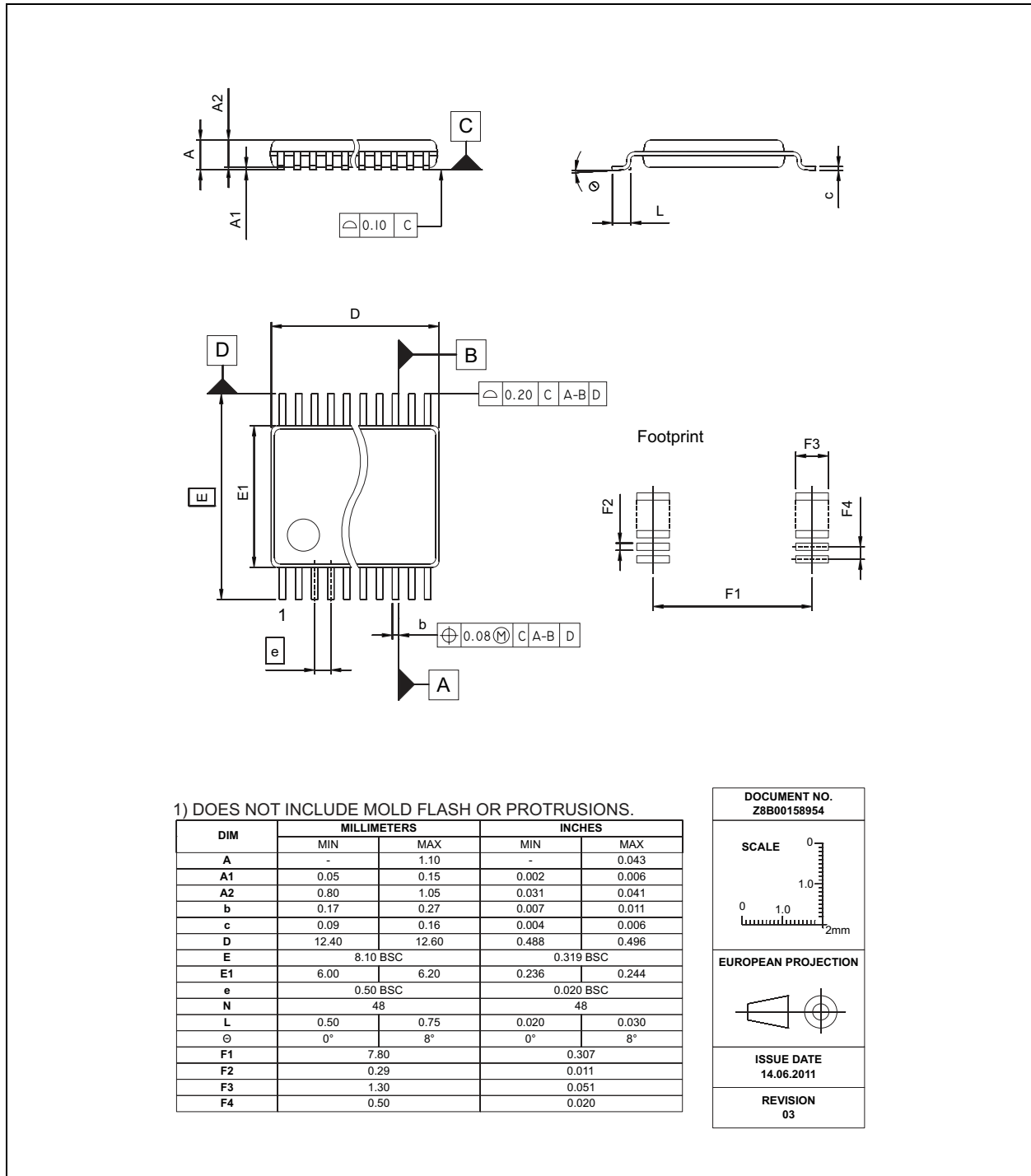

Figure 7-1 Package Outline TSSOP-48 (tie bar not drawn in outline)

Notes

- You can find all of our packages, sorts of packing and others in our Infineon Internet Page "Packages": <http://www.infineon.com/packages>
- Dimensions in mm.

www.infineon.com

Published by Infineon Technologies AG