

Evaluation Board for the **ADP2323**, Dual 3 A, 20 V, Synchronous Step-Down Regulator with Integrated High-Side MOSFET

FEATURES

- Input voltage: 4.5 V to 20 V**
- ±1% output voltage accuracy**
- Integrated 90 mΩ typical on-resistance high-side MOSFET**
- Flexible output configuration**
 - Dual output: 3 A/3 A**
 - Parallel single output: 6 A**
- Programmable switching frequency: 250 kHz to 1.2 MHz**
- External synchronization input with programmable phase shift, or internal clock output**
- Selectable PWM or PFM mode operation**
- Adjustable current limit for small inductor**
- External compensation and soft start**
- Startup into precharged output**

GENERAL DESCRIPTION

The **ADP2323** evaluation board is a complete, dual, 3 A step-down regulator solution that allows users to evaluate the performance of the **ADP2323** with a near ideal printed circuit board (PCB) layout.

The two pulse-width modulation (PWM) channels can be configured to deliver dual, 3 A outputs or a parallel-to-single, 6 A output. The switching frequency can be programmed between 250 kHz and 1.2 MHz, or it can be synchronized to an external clock with a programmed 60°, 90°, or 120° phase shift, which provides the possibility for a stackable multiphase power solution.

The outputs of the **ADP2323** evaluation board are preset to 1.2 V and 3.3 V for Channel 1 and Channel 2, respectively. With the PWM mode selected, the switching frequency is set to 500 kHz. Different output voltage settings and configurations can be achieved by changing appropriate passive components or jumper settings. The ambient temperature operating range is -40°C to +85°C.

Full details on the **ADP2323** dual regulator are provided in the **ADP2323** data sheet, available from Analog Devices, Inc., which should be consulted in conjunction with this user guide.

ADP2323 DEMO BOARD

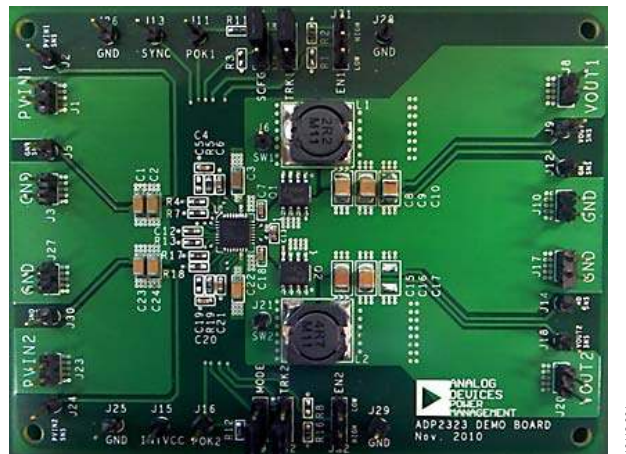

Figure 1.

TABLE OF CONTENTS

Features	1	Modifying the Board.....	4
General Description	1	Evaluation Board Schematic and Artwork.....	6
ADP2323 Demo Board.....	1	ADP2323 Schematic	6
Revision History	2	PCB Layout	7
Using the Evaluation Board.....	3	Ordering Information.....	11
Powering Up.....	3	Bill of Materials.....	11
Measuring Evaluation Board Performance	4		

REVISION HISTORY

8/11—Revision 0: Initial Version

USING THE EVALUATION BOARD

POWERING UP

The [ADP2323](#) evaluation board is supplied fully assembled and tested. Before applying power to the evaluation board, follow the procedures in this section.

Jumper J31/Jumper J32 (Enable)

Jumper J31 is used to control Channel 1. Use one of the following methods to enable or to disable Channel 1:

- To enable Channel 1, short the middle pin of J31, EN1, to high or leave it open.
- To disable Channel 1, short the middle pin of J31, EN1, to low and remove R2.

Jumper J32 is used to control Channel 2. Use one of the following methods to enable or disable Channel 2:

- To enable Channel 2, short the middle pin of J32, EN2, to high or leave it open.
- To disable Channel 2, short the middle pin of J32, EN2, to low and remove R16.

Jumper J4/Jumper J22 (TRACK)

When the tracking function is not used, short the middle pin of J4, TRK1, and J22, TRK2, to high.

Jumper J19 (MODE)

Jumper J19 is used to select the working mode of the [ADP2323](#). Use one of the following methods to set the regulator to operate in PWM or PFM mode.

- To operate in PWM mode, short the middle pin of J19 to high.
- To operate in PFM mode, short the middle pin of J19 to low.

Jumper J7 (SCFG)

Jumper J7 is used to configure the SYNC pin as an input or an output. Short the middle pin of J7 to high to set the SYNC pin as an output. To sync the regulator to an external clock, set the SYNC pin as an input.

External Synchronization

To synchronize the regulator to an external clock, refer to Table 1 for proper configuration of the SCFG pin and the SYNC pin.

Table 1. SCFG Configuration

J7 (SCFG)	R3	SYNC	Phase Shift
High	No connect	Output	0°
Low	No connect	Input	90°
Open	180 kΩ	Input	120°
Open	100 kΩ	Input	60°

When the SYNC pin is configured as an output, it generates a clock with a frequency that is equal to the internal switching frequency.

When the SYNC pin is configured as an input, the [ADP2323](#) synchronizes to an external clock applied to the SYNC pin, and the internal clock must be programmed lower than the external clock.

When operating in synchronization mode, PFM mode is disabled, and the ADP2323 only operates in continuous conduction mode (CCM) mode.

Input Power Source

If the input power source includes a current meter, use that meter to monitor the input current. Connect the positive terminal of the power source to J1 and J23 (PVIN1 and PVIN2, respectively) of the evaluation board, and the negative terminal of the power source to J3 and J27 (GND) of the evaluation board.

If the power source does not include a current meter, connect a current meter in series with the input source voltage. Connect the positive lead (+) of the power source to the positive (+) ammeter terminal, the negative lead (–) of the power source to J3 and J27 (GND), and the negative lead (–) of the ammeter to J1 and J23 (PVIN1 and PVIN2, respectively).

Output Load

Before connecting the load, ensure that the board is turned off. Connect an electronic load or resistor to set the load current.

To connect a load to the output of Channel 1, connect the positive terminal of the load to J8 (VOUT1) of the evaluation board and connect the negative terminal of the load to J10 (GND).

To connect a load to the output of Channel 2, connect the positive terminal of the load to J20 (VOUT2) of the evaluation board and connect the negative terminal of the load to J17 (GND).

Input and Output Voltmeter

Measure the input and output voltages using voltmeters. Make sure that the voltmeters are connected to the appropriate terminals of evaluation board and not to the load or power source. If the voltmeters are not connected directly to the evaluation board, the measured voltages are incorrect due to the voltage drop across the leads and/or connections between the evaluation board, the power source, and/or the load.

To measure the input voltage, connect the positive terminal of the voltmeter to J2 (PVIN1_SNS) or J24 (PVIN2_SNS) and the negative terminal to J5 or J30 (GND_SNS). Likewise, to measure the output voltage, connect the positive terminal of the voltmeter to J9 (VOUT1_SNS) or J18 or (VOUT2_SNS) and the negative terminal to J12 or J14 (GND_SNS).

Turning On the Evaluation Board

When the power source and load are connected to the evaluation board, it can be powered for operation.

Perform the following steps to turn on the board:

1. Ensure that the power source voltage is >4.5 V and <20 V.
2. Ensure that EN1 and EN2 are high and monitor the output voltage.
3. Turn on the load, check that it is drawing the proper load current, and verify that the output voltage maintains its regulation.

MEASURING EVALUATION BOARD PERFORMANCE

Measuring the Switching Waveform

To observe the switching waveform with an oscilloscope, place the oscilloscope probe tip at Test Point J6 (SW1) and J21 (SW2) with the probe ground at GND. Set the scope to dc with the appropriate voltage and time divisions. The switching waveform limits should alternate approximately between 0 V and the input voltage.

Measuring Load Regulation

Load regulation can be tested by observing the change in the output voltage with increasing output load current. To minimize the voltage drop, use short low resistance wires.

Measuring Line Regulation

Vary the input voltage and examine the change in the output voltage with a fixed output current.

Line Transient Response

Generate a step input voltage change and observe the behavior of the output voltage using an oscilloscope.

Load Transient Response

Generate a load current transient at the output and observe the output voltage response using an oscilloscope. Attach the current probe to the wire between the output and the load to capture the current transient waveform.

Measuring Efficiency

The efficiency, η , is measured by comparing the input power with the output power.

$$\eta = \frac{V_{OUT} \times I_{OUT}}{V_{IN} \times I_{IN}}$$

Measure the input and output voltages as close as possible to the input and output capacitors to reduce the effect of voltage drop.

Measuring Inductor Current

The inductor current can be measured by removing one end of the inductor from its pad and connecting a current loop in series. A current probe can be connected onto this wire.

Measuring Output Voltage Ripple

To observe the output voltage ripple, place the oscilloscope probe across the output capacitor with the probe ground lead connected to the negative (–) capacitor terminal and the probe tip placed at the positive (+) capacitor terminal. Set the oscilloscope to ac, 10 mV/division, 2 μ s/division time base, and 20 MHz bandwidth.

A standard oscilloscope probe has a long wire ground clip. For high frequency measurements, this ground clip picks up high frequency noise and injects it into the measured output ripple. Figure 2 shows an easy way to measure the output ripple properly. It requires removing the oscilloscope probe sheath and wrapping an unshielded wire around the oscilloscope probe. By keeping the ground length of the oscilloscope probe as short as possible, the true ripple can be measured.

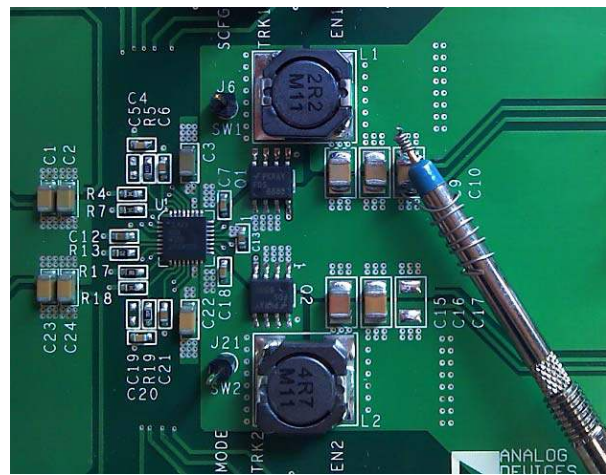

Figure 2. Measuring Output Voltage Ripple

MODIFYING THE BOARD

To modify the [ADP2323](#) evaluation board configuration, unsolder and/or replace/remove the appropriate passive components or jumpers on the board.

Changing the Output Voltages

The output voltage setpoints of the [ADP2323](#) can be changed by replacing the R4, R7, R18, and R17 resistors with the resistor values shown in Table 2.

Table 2. Resistive Divider for Various Output Voltages

V _{OUT} (V)	R4/R18, ±1% (k Ω)	R7/R17, ±1% (k Ω)
1.0	10	15
1.2	10	10
1.5	15	10
1.8	20	10
2.5	47.5	15
3.3	10	2.21
5.0	22	3

To limit output voltage accuracy degradation due to the FB_x pin bias current (0.1 μ A maximum) to less than 0.5% (maximum), ensure that the bottom divider string resistor, R7 (R17 for Channel 2), is less than 30 k Ω .

The top resistor, R4 (R18 for Channel 2), value is calculated using the following equations:

For Channel 1,

$$R4 = R7 \times \left(\frac{V_{OUT1} - 0.6 \text{ V}}{0.6 \text{ V}} \right)$$

For Channel 2,

$$R18 = R17 \times \left(\frac{V_{OUT2} - 0.6 \text{ V}}{0.6 \text{ V}} \right)$$

When the output voltage of Channel 1 is changed, the values of the inductor (L1), the output capacitors (C8, C9, and C10), and the compensation components (R5, C4, and C5) must be recalculated and changed to ensure stable operation (see the [ADP2323](#) data sheet for details on external component selection). Likewise, if the output voltage of Channel 2 is changed, the values of the inductor (L2), the output capacitors (C15, C16, and C17), and the compensation components (R19, C20, and C19) must be recalculated and changed.

Changing the Switching Frequency

The switching frequency (f_{sw}) set point can be changed by replacing the R13 resistor with a different value, as shown in the following equation:

$$f_{sw} [\text{kHz}] = 60,000/R13 [\text{k}\Omega]$$

A 200 k Ω resistor sets the frequency to 300 kHz, and a 100 k Ω resistor sets the frequency to 600 kHz.

When the switching frequency is changed, the values of the inductor (L1 and L2), the output capacitors (C8, C9, C10 and C15, C16, C17), the compensation networks (R5, C4, C5 and R19, C20, C19) must be recalculated and changed for stable operation (see the [ADP2323](#) data sheet for details on external component selection).

Changing the Soft Start Time

The soft start time of the [ADP2323](#) on the evaluation board is programmed to 1.7 ms.

To change the soft start time, t_{ss} , replace the C6 capacitor for Channel 1 (C21 for Channel 2) with a different capacitor value using the following equation:

For Channel 1,

$$C6 [\text{nF}] = 5.83 \times t_{ss} [\text{ms}]$$

For Channel 2,

$$C21 [\text{nF}] = 5.83 \times t_{ss} [\text{ms}]$$

Changing the Peak Current-Limit Threshold

The peak current-limit threshold of the [ADP2323](#) evaluation board is set to 4.8 A.

To change the peak current-limit threshold, replace the R9 resistor for Channel 1 (R14 for Channel 2) with a different resistor value, as shown in Table 3. The programmable current-limit threshold feature allows for the use of a small size inductor for low current applications.

Table 3. Peak Current-Limit Threshold Setting

R9/R14	Peak Current-Limit Threshold (A)
Open	4.8
47 k Ω	3
15 k Ω	1.5

EVALUATION BOARD SCHEMATIC AND ARTWORK

ADP2323 SCHEMATIC

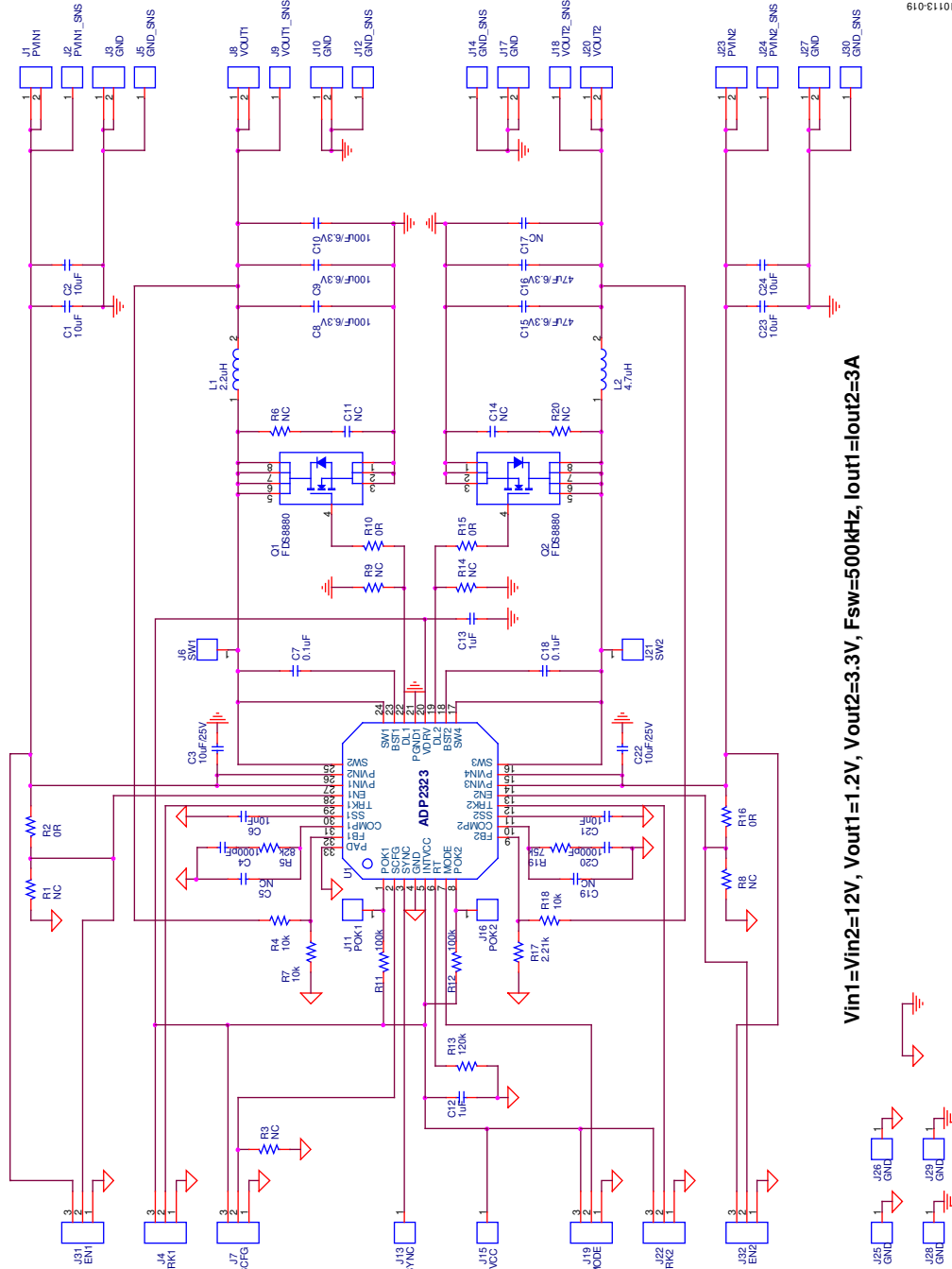

Figure 3. Evaluation Board Schematic for ADP2323

PCB LAYOUT

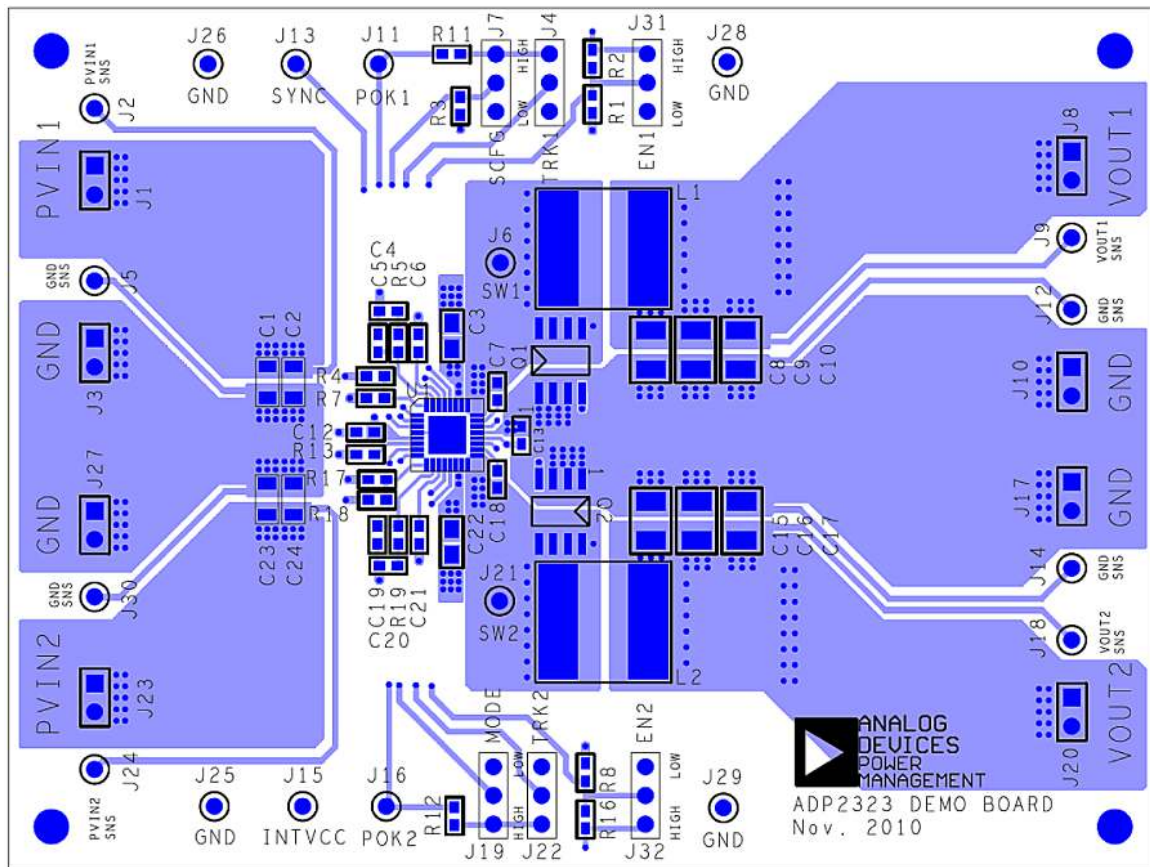
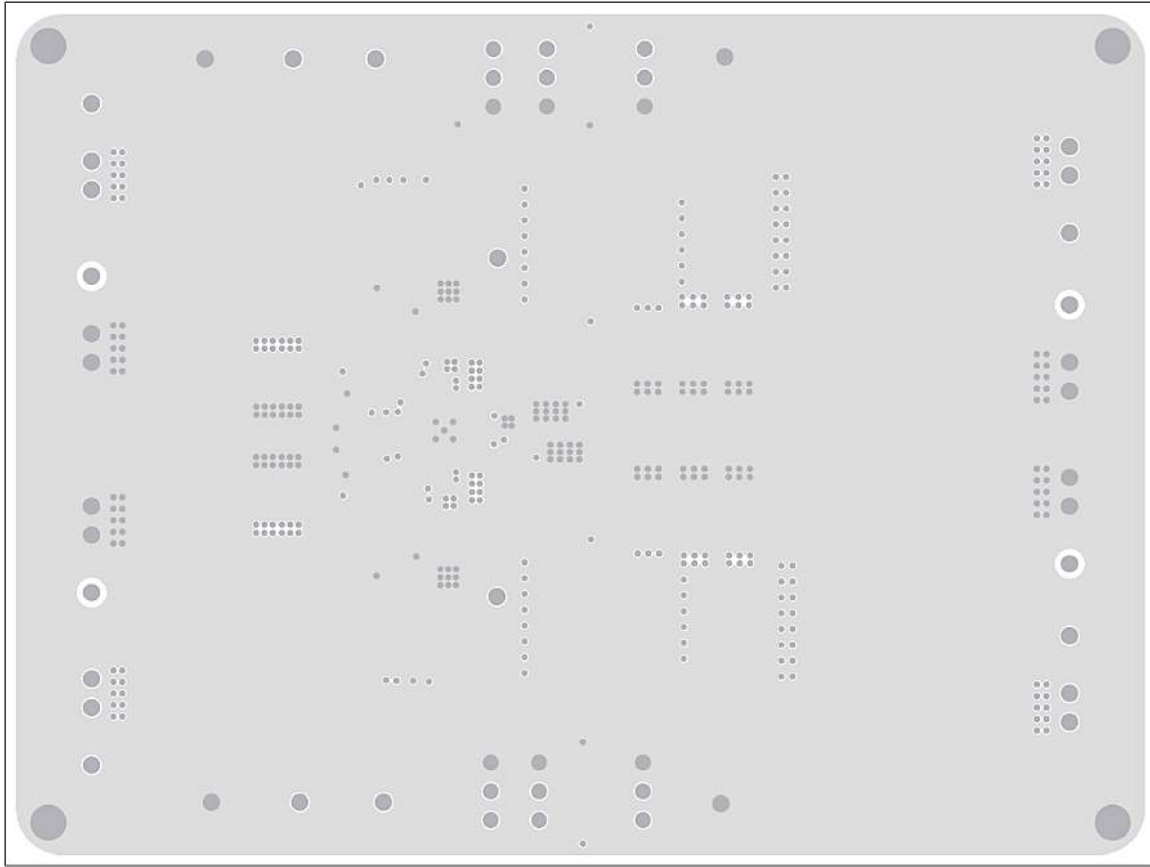

Figure 4. Layer 1, Component Side

10113420



1013-021

Figure 5. Layer 2, Ground Plane

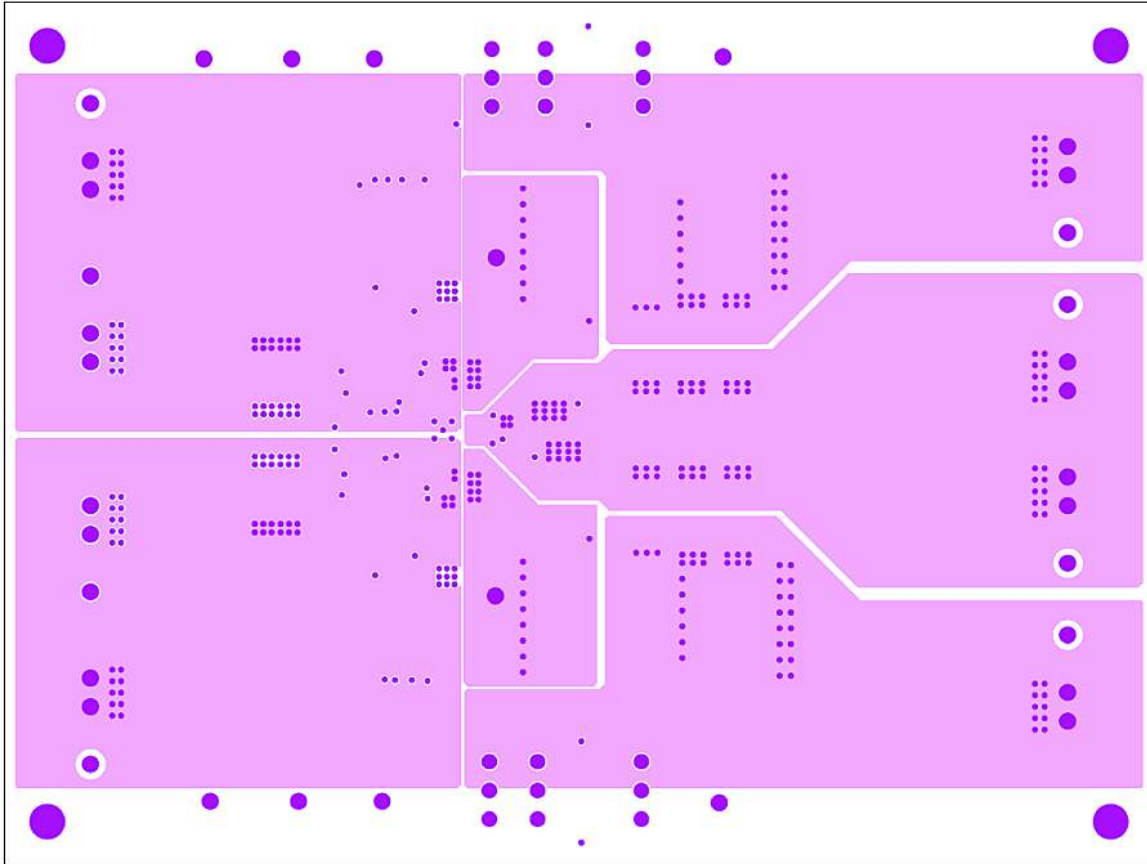

1013-022

Figure 6. Layer 3, Power Plane

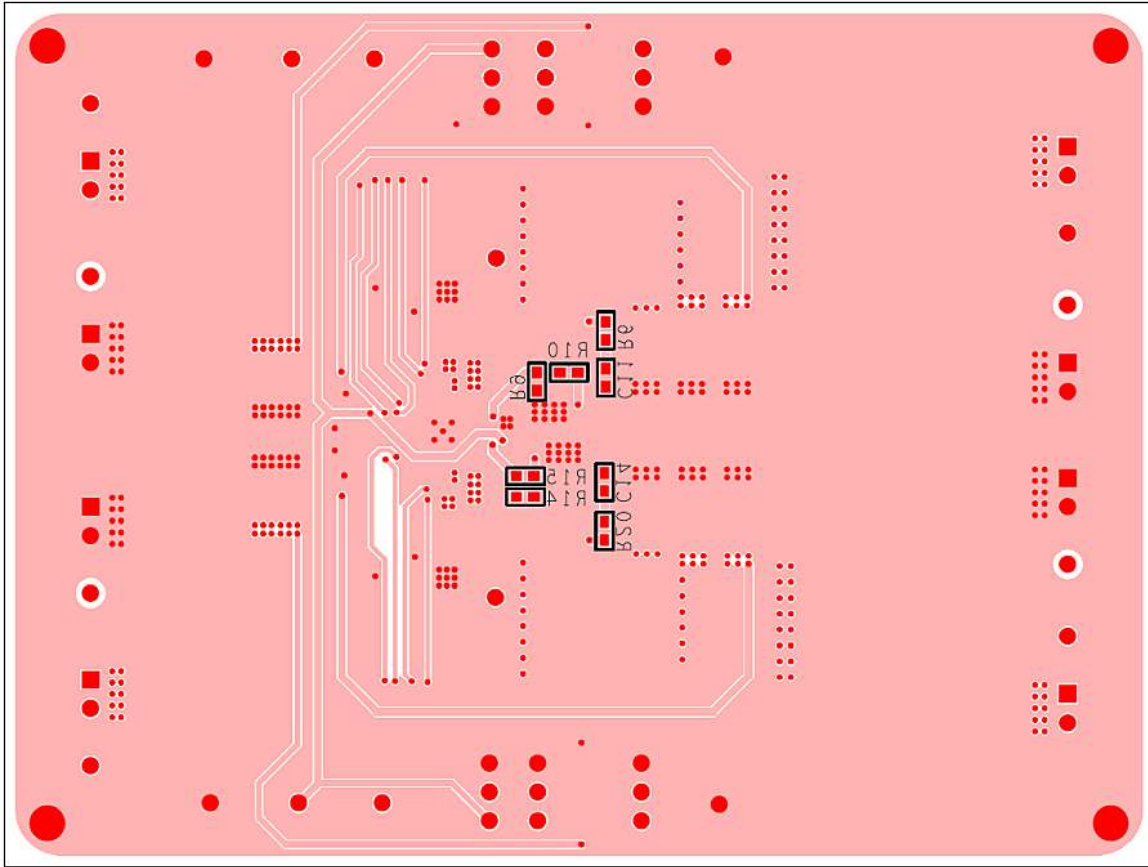

10113-023

Figure 7. Layer 4, Bottom Side

ORDERING INFORMATION

BILL OF MATERIALS

Table 4.

Qty	Reference Designator	Description	Part Number/Vendor
4	C1, C2, C23, C24	10 μ F, 25 V, capacitor, 1206	GRM31CR61E106KA12L/Murata
2	C3, C22	10 μ F, 25 V, capacitor, 0805	GRM21BR61E106KA73L/Murata
2	C4, C20	1000 pF, 25 V, capacitor, 0603	GRM188R71E102KA01D/Murata
4	C5, C11, C14, C19	Optional, capacitor, 0603	Optional/Murata
2	C6, C21	10 nF, 16 V, capacitor, 0603	GRM188R71C103KA01D/Murata
2	C7, C18	0.1 μ F, 16 V, capacitor, 0603	GRM188R71C104KA01D/Murata
3	C8, C9, C10	100 μ F, 6.3 V, capacitor, 1210	GRM32ER60J107ME20L/Murata
1	C17	Optional, capacitor, 1210	Optional/Murata
2	C12, C13	1 μ F, 6.3 V, capacitor, 0603	GRM188R70J105KA01D/Murata
2	C15, C16	47 μ F, 6.3 V, capacitor, 1210	GRM32ER70J476KE19L/Murata
1	L1	Inductor, CDRH105R, L = 2.2 μ H, I _{RAT} = 9.25 A, DCR = 5.6 m Ω	CDRH105RNP-2R2N/Sumida
1	L2	Inductor, CDRH105R, L = 4.7 μ H, I _{RAT} = 6.4 A, DCR = 9.5 m Ω	CDRH105RNP-4R7N/Sumida
2	Q1, Q2	N-Channel MOSFET, V _{DS} = 30 V, R _{DS(ON)} = 9.6 m Ω , I _D = 10.7 A, SO8	FDS8880/Fairchild
7	R1, R3, R6, R8, R9, R14, R20	Optional, resistor, 0603	Optional/Vishay Dale
4	R2, R10, R15, R16	0 Ω , 1%, resistor, 0603	CRCW06030000Z0EA/Vishay Dale
3	R4, R7, R18	10 k Ω , 1%, resistor, 0603	CRCW060310K0FKEA/Vishay Dale
1	R5	82 k Ω , 1%, resistor, 0603	CRCW060382K0FKEA/Vishay Dale
2	R11, R12	100 k Ω , 1%, resistor, 0603	CRCW0603100KFKEA/Vishay Dale
1	R13	120 k Ω , 1%, resistor, 0603	CRCW0603120KFKEA/Vishay Dale
1	R17	2.21 k Ω , 1%, resistor, 0603	CRCW06032K21FKEA/Vishay Dale
1	R19	75 k Ω , 1%, resistor, 0603	CRCW060375K0FKEA/Vishay Dale
1	U1	Dual 3 A, 20 V, synchronous, step-down regulator with integrated high-side MOSFET, 32-lead, LFCSP_WQ, with exposed paddle	ADP2323/Analog Devices, Inc.
18	J2, J5, J6, J9, J11, J12, J13, J14, J15, J16, J18, J21, J24, J25, J26, J28, J29, J30	Test point, 2.54 mm pitch SIL vertical PC tail pin header, 6.1 mm mating pin height, tin, SIP1	M20-9990245/Harwin
8	J1, J3, J8, J10, J17, J20, J23, J27	Connector, 2.54 mm pitch SIL vertical PC tail pin header, 6.1 mm mating pin height, tin, 2-way, SIP2	M20-9990245/Harwin
6	J4, J7, J19, J22, J31, J32	Jumper, 0.1-inch header, 3-way, SIP3	M20-9990346/Harwin

NOTES

**ESD Caution**

ESD (electrostatic discharge) sensitive device. Charged devices and circuit boards can discharge without detection. Although this product features patented or proprietary protection circuitry, damage may occur on devices subjected to high energy ESD. Therefore, proper ESD precautions should be taken to avoid performance degradation or loss of functionality.

Legal Terms and Conditions

By using the evaluation board discussed herein (together with any tools, components documentation or support materials, the "Evaluation Board"), you are agreeing to be bound by the terms and conditions set forth below ("Agreement") unless you have purchased the Evaluation Board, in which case the Analog Devices Standard Terms and Conditions of Sale shall govern. Do not use the Evaluation Board until you have read and agreed to the Agreement. Your use of the Evaluation Board shall signify your acceptance of the Agreement. This Agreement is made by and between you ("Customer") and Analog Devices, Inc. ("ADI"), with its principal place of business at One Technology Way, Norwood, MA 02062, USA. Subject to the terms and conditions of the Agreement, ADI hereby grants to Customer a free, limited, personal, temporary, non-exclusive, non-sublicensable, non-transferable license to use the Evaluation Board FOR EVALUATION PURPOSES ONLY. Customer understands and agrees that the Evaluation Board is provided for the sole and exclusive purpose referenced above, and agrees not to use the Evaluation Board for any other purpose. Furthermore, the license granted is expressly made subject to the following additional limitations: Customer shall not (i) rent, lease, display, sell, transfer, assign, sublicense, or distribute the Evaluation Board; and (ii) permit any Third Party to access the Evaluation Board. As used herein, the term "Third Party" includes any entity other than ADI, Customer, their employees, affiliates and in-house consultants. The Evaluation Board is NOT sold to Customer; all rights not expressly granted herein, including ownership of the Evaluation Board, are reserved by ADI. CONFIDENTIALITY. This Agreement and the Evaluation Board shall all be considered the confidential and proprietary information of ADI. Customer may not disclose or transfer any portion of the Evaluation Board to any other party for any reason. Upon discontinuation of use of the Evaluation Board or termination of this Agreement, Customer agrees to promptly return the Evaluation Board to ADI. ADDITIONAL RESTRICTIONS. Customer may not disassemble, decompile or reverse engineer chips on the Evaluation Board. Customer shall inform ADI of any occurred damages or any modifications or alterations it makes to the Evaluation Board, including but not limited to soldering or any other activity that affects the material content of the Evaluation Board. Modifications to the Evaluation Board must comply with applicable law, including but not limited to the RoHS Directive. TERMINATION. ADI may terminate this Agreement at any time upon giving written notice to Customer. Customer agrees to return to ADI the Evaluation Board at that time. LIMITATION OF LIABILITY. THE EVALUATION BOARD PROVIDED HEREUNDER IS PROVIDED "AS IS" AND ADI MAKES NO WARRANTIES OR REPRESENTATIONS OF ANY KIND WITH RESPECT TO IT. ADI SPECIFICALLY DISCLAIMS ANY REPRESENTATIONS, ENDORSEMENTS, GUARANTEES, OR WARRANTIES, EXPRESS OR IMPLIED, RELATED TO THE EVALUATION BOARD INCLUDING, BUT NOT LIMITED TO, THE IMPLIED WARRANTY OF MERCHANTABILITY, TITLE, FITNESS FOR A PARTICULAR PURPOSE OR NON-INFRINGEMENT OF INTELLECTUAL PROPERTY RIGHTS. IN NO EVENT WILL ADI AND ITS LICENSORS BE LIABLE FOR ANY INCIDENTAL, SPECIAL, INDIRECT, OR CONSEQUENTIAL DAMAGES RESULTING FROM CUSTOMER'S POSSESSION OR USE OF THE EVALUATION BOARD, INCLUDING BUT NOT LIMITED TO LOST PROFITS, DELAY COSTS, LABOR COSTS OR LOSS OF GOODWILL. ADI'S TOTAL LIABILITY FROM ANY AND ALL CAUSES SHALL BE LIMITED TO THE AMOUNT OF ONE HUNDRED US DOLLARS (\$100.00). EXPORT. Customer agrees that it will not directly or indirectly export the Evaluation Board to another country, and that it will comply with all applicable United States federal laws and regulations relating to exports. GOVERNING LAW. This Agreement shall be governed by and construed in accordance with the substantive laws of the Commonwealth of Massachusetts (excluding conflict of law rules). Any legal action regarding this Agreement will be heard in the state or federal courts having jurisdiction in Suffolk County, Massachusetts, and Customer hereby submits to the personal jurisdiction and venue of such courts. The United Nations Convention on Contracts for the International Sale of Goods shall not apply to this Agreement and is expressly disclaimed.