

| LOC | | DIST | | REVISIONS | | | |
|-----|-----|---------------------------|-----------|-----------|------|-----|----|
| P | LTR | DESCRIPTION | DATE | DMN | APVD | REV | BY |
| B | | REVISED PER ECO-14-011808 | 12AUG2014 | AP | SB | | |

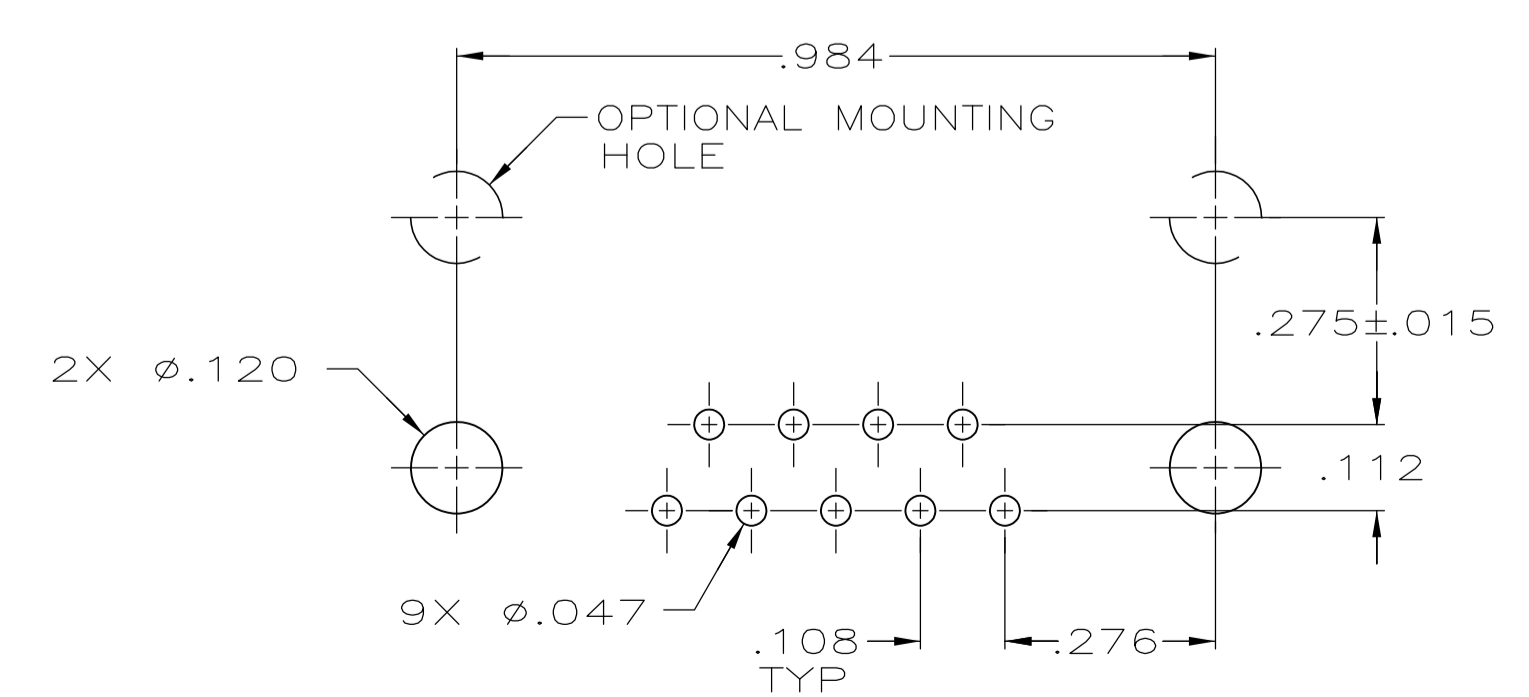
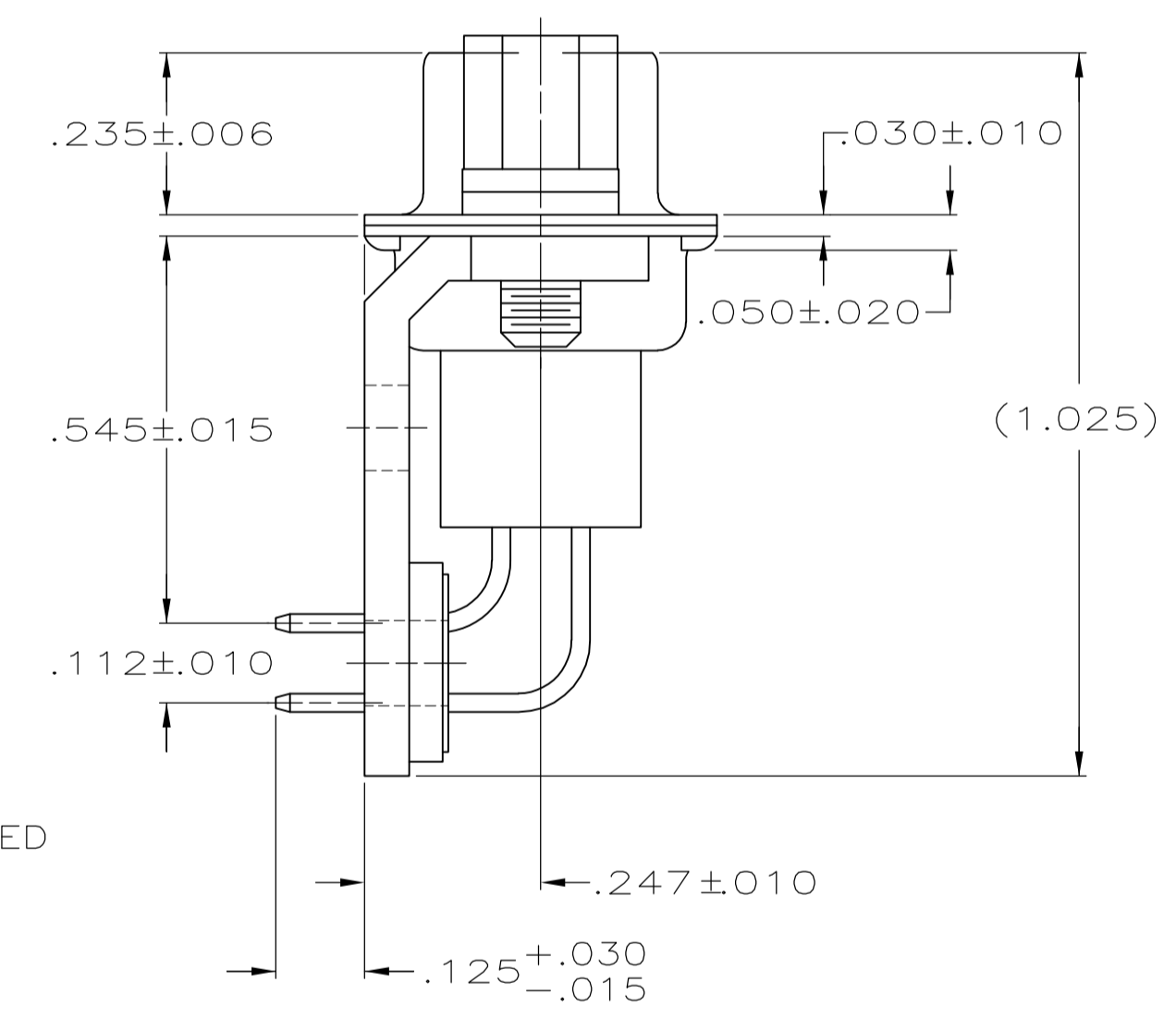
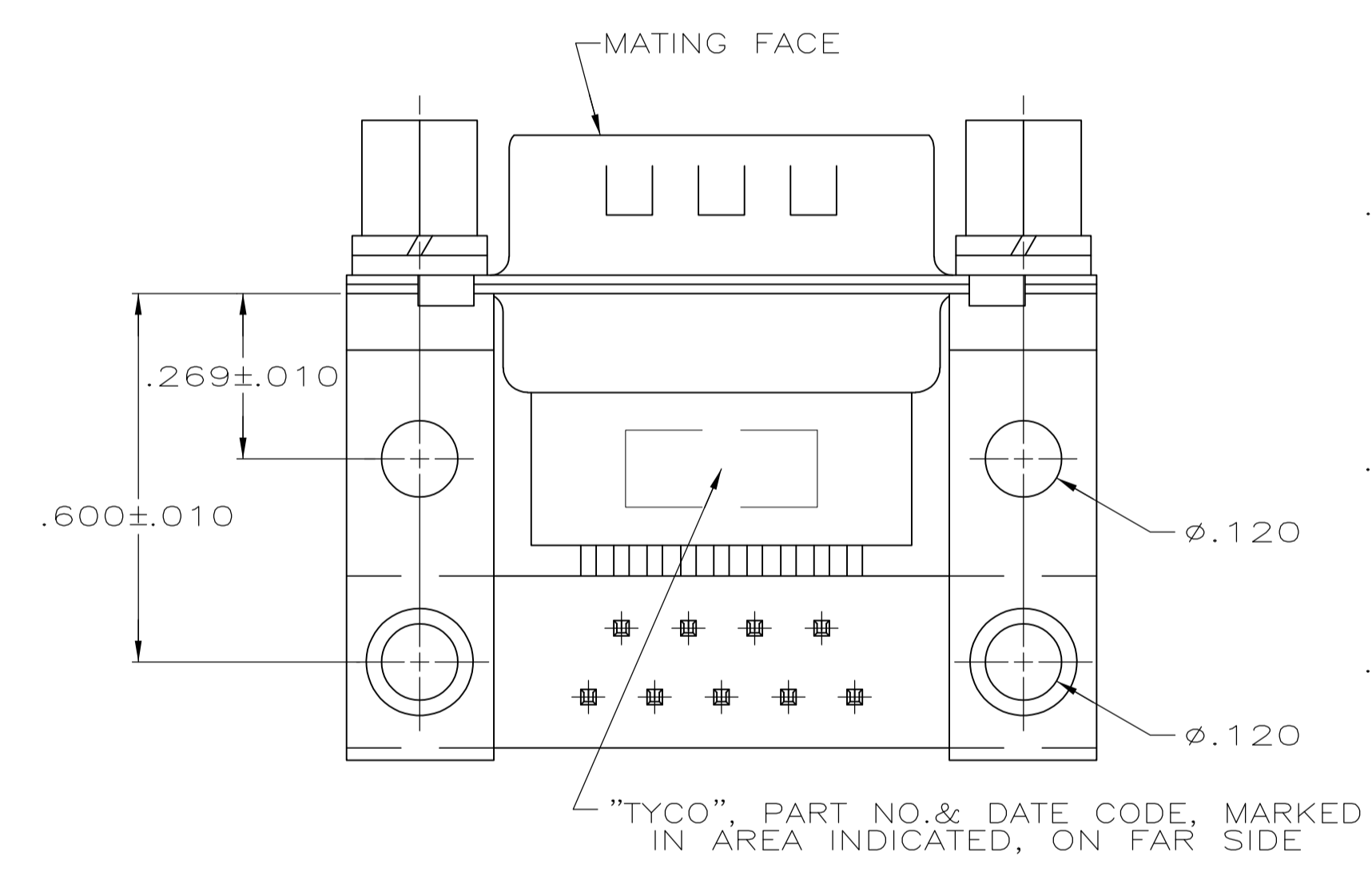
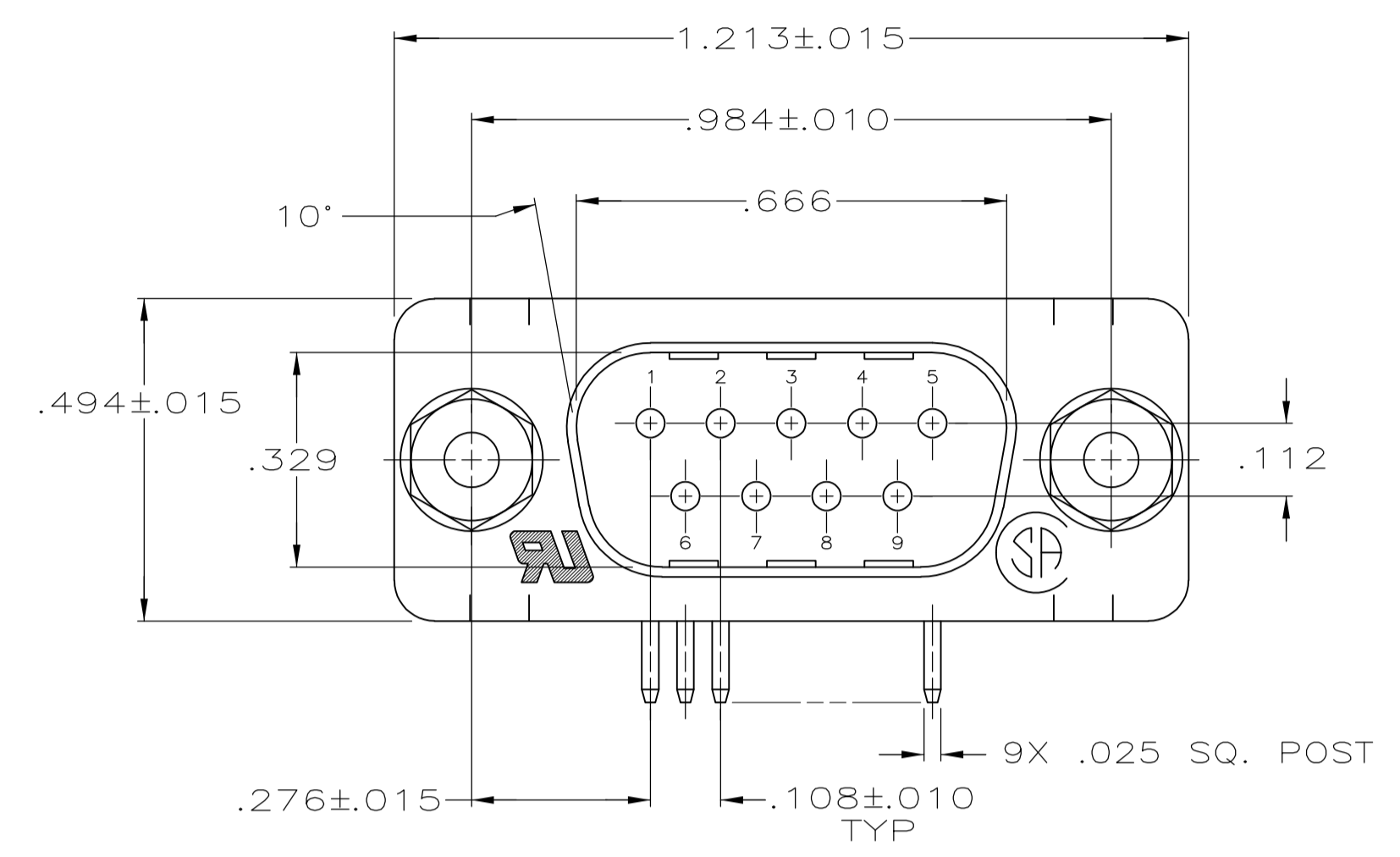

P.C. BOARD MOUNTING DIMENSIONS

△ MOLDED PARTS: GLASS-FILLED PBT OR GLASS-FILLED NYLON, UL94V-0 RATED. COLOR: BLACK.
 SHELLS & BRACKETS: CARBON STEEL.
 CONTACTS: BRASS
 SCREWLOCKS AND WASHERS: CARBON STEEL.

△ SHELLS: .000200 MIN TIN OVER .000100 MIN COPPER.
 BRACKETS: .000200 MIN TIN OVER .000050 MIN COPPER.
 SCREWLOCKS AND WASHERS: ZINC PLATED WITH CLEAR CHROMATE COATING.
 CONTACTS: GOLD PLATED FOR A LENGTH OF .150 MIN FROM MATING END, .000030 MIN GOLD IN MATED AREA, .000100 MIN TIN ON OPPOSITE END, BOTH OVER .000050 MIN NICKEL.
 -OR-
 GOLD FLASH OVER PALLADIUM NICKEL PLATED FOR A LENGTH OF .150 MIN FROM MATING END, .000030 MIN PALLADIUM NICKEL IN MATED AREA, .000100 MIN TIN ON OPPOSITE END, BOTH OVER .000050 MIN NICKEL.

5747197-4
 PART NUMBER

| | | | |
|--|--------|------------------------------|-----------------|
| THIS DRAWING IS A CONTROLLED DOCUMENT. | | DIN D. HENNY 9-4-05 | TE Connectivity |
| | | CHK S. BOLASH 9-4-05 | |
| DIMENSIONS: INCHES | | APVD M. WALMSLEY 9-4-05 | NAME |
| TOLERANCES UNLESS OTHERWISE SPECIFIED: | | PRODUCT SPEC | |
| 0. PLC | ± .005 | 108-40025 | |
| 1. PLC | ± .005 | APPLICATION SPEC | |
| 2. PLC | ± .005 | 114-40013 | |
| 3. PLC | ± .005 | SIZE | |
| 4. PLC | ± .005 | A1 | |
| ANGLES | ± .2° | DRAWING NO | |
| MATERIAL | 1 | WEIGHT | |
| FINISH | 2 | 00779 | |
| | | CUSTOMER DRAWING | |
| | | SCALE 4:1 SHEET 1 OF 1 REV B | |