

THIS DRAWING IS UNPUBLISHED. RELEASED FOR PUBLICATION
 © COPYRIGHT - T1 ALL RIGHTS RESERVED.

REVISIONS					
P	LTR	DESCRIPTION	DATE	DWN	APVD
U		REVISED PER ECO-12-012316	05JUL12	KH	MZ
V		REVISED PER ECO-16-017885	06OCT2017	RS	MZ

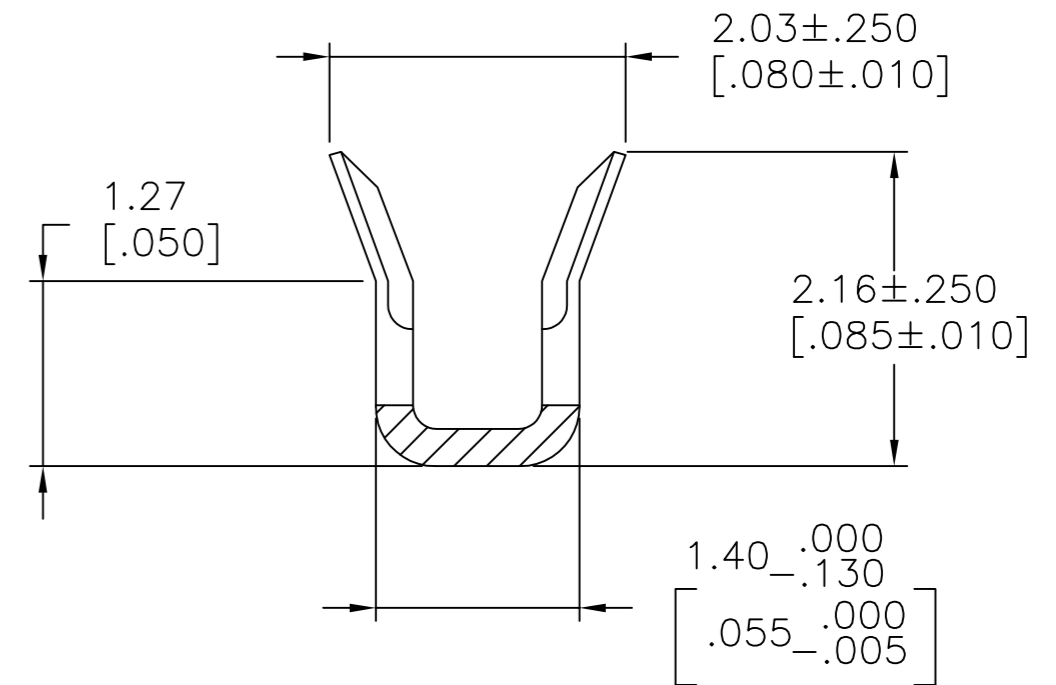

SECTION A-A

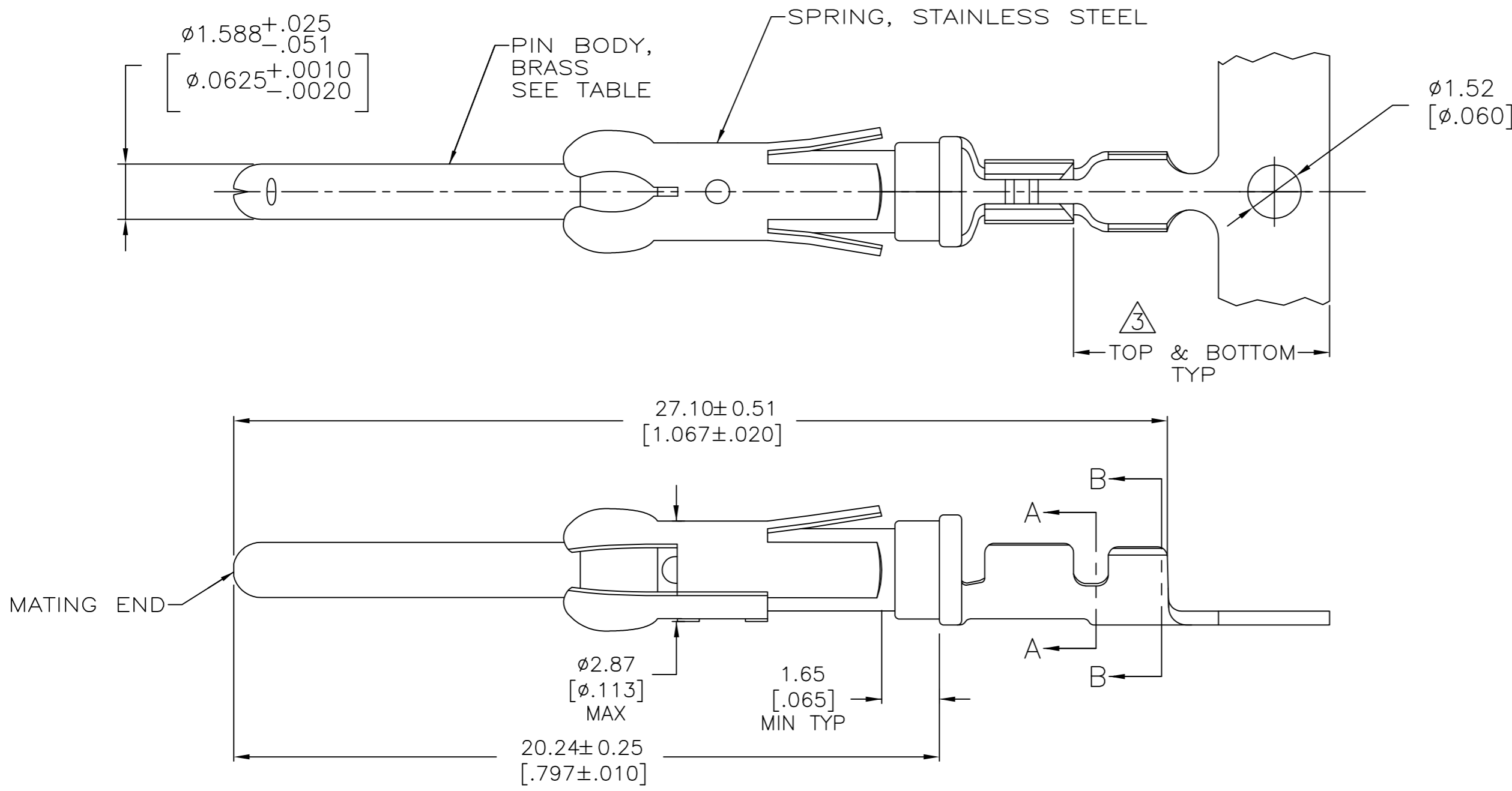
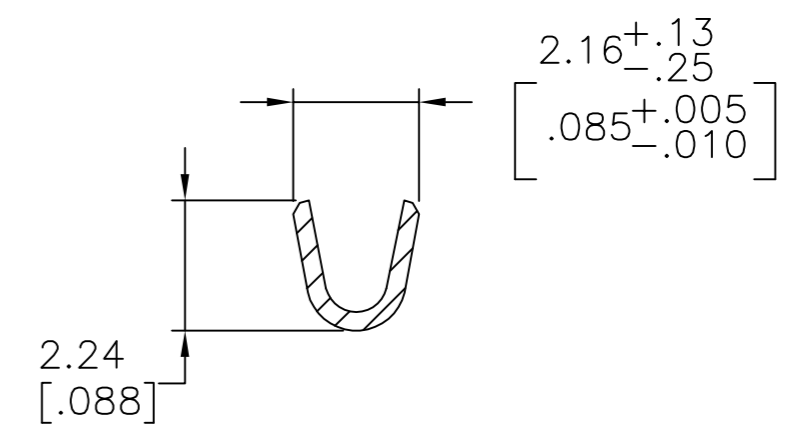

SECTION B-B

- 1. $0.76 \mu\text{m}$ [$.000030$] MIN PRECIOUS METAL PLATE ON MATING END FOR A LENGTH OF 5.08 [$.200$] MIN WITH $1.27 \mu\text{m}$ [$.000050$] MIN MATTE TIN PLATE IN WIRE CRIMP AREA, BOTH OVER $1.27 \mu\text{m}$ [$.000050$] MIN NICKEL PLATE. CONFORMS TO THE REQUIREMENTS OF TE CONNECTIVITY PRODUCT SPEC 108-10042, BASED ON EIA/ECA-364-1000.01A (CONTROLLED ENVIRONMENT APPLICATIONS).
- 2. REELED FOR MINI-APPLICATOR.
- 3. GOLD PLATING NEED NOT APPEAR IN THIS AREA.
- 4. $0.76 \mu\text{m}$ [$.000030$] MIN PRECIOUS METAL PLATE ON MATING END FOR A LENGTH OF 5.08 [$.200$] MIN WITH A UNIFORM GRADIENT TO $0.25 \mu\text{m}$ [$.000010$] ON REMAINDER, OVER $1.27 \mu\text{m}$ [$.000050$] MIN NICKEL PLATE. GOLD FLASH ALL OVER. CONFORMS TO THE REQUIREMENTS OF TE CONNECTIVITY PRODUCT SPEC 108-10042, BASED ON EIA/ECA-364-1000.01A (CONTROLLED ENVIRONMENT APPLICATIONS).
- 5. $0.38 \mu\text{m}$ [$.000015$] MIN GOLD PER MIL-G-45204 ON MATING END FOR A LENGTH OF 5.08 [$.200$] MIN WITH $1.27 \mu\text{m}$ [$.000050$] MIN MATTE TIN PLATE IN WIRE CRIMP AREA, BOTH OVER $1.27 \mu\text{m}$ [$.000050$] NICKEL PER QQ-N-290.
- 6. WIRE RANGE 26-30 AWG.
- 7. INSULATION RANGE 1.02 [$.040$]- 1.52 [$.060$] DIA.
- 8. $1.27 \mu\text{m}$ [$.000050$] MIN TIN-LEAD PER MIL-T-10727 OVER $1.27 \mu\text{m}$ [$.000050$] MIN NICKEL PER QQ-N-290.
- 9. $0.38 \mu\text{m}$ [$.000015$] MIN GOLD PER MIL-G-45204 ON MATING END FOR A LENGTH OF 5.08 [$.200$] MIN, 1.27 MIL-T-10727 FOR A LENGTH OF 5.69 [$.224$] MIN ON OPPOSITE END, BOTH OVER $1.27 \mu\text{m}$ [$.000050$] MIN NICKEL PER QQ-N-290 ON ENTIRE CONTACT.
- 10. $1.27 \mu\text{m}$ [$.000050$] MIN TIN PER MIL-T-10727 OVER $1.27 \mu\text{m}$ [$.000050$] MIN NICKEL PER QQ-N-290.

	2	10	-	1-66425-2
OBSOLETE	2	9	66429-6	1-66425-1
	2	1	66429-4	66425-8
	2	5	66429-3	66425-7
OBSOLETE	2	8	-	66425-6
OBSOLETE	2	4	66429-1	66425-5
	STANDARD	1	66429-4	66425-4
	STANDARD	5	66429-3	66425-3
OBSOLETE	STANDARD	4	66429-1	66425-1
	REELING	PIN BODY FINISH	LOOSE PIECE REF	PART NO.

THIS DRAWING IS A CONTROLLED DOCUMENT.		DWN V. FURLER 28JUL03		
DIMENSIONS: mm [INCHES]		CHK G. STEINHAUER 28JUL03		
TOLERANCES UNLESS OTHERWISE SPECIFIED:		APVD G. STEINHAUER 28JUL03	NAME	
0 PLC ± -		PRODUCT SPEC	PIN ASSEMBLY, .062, TYPE III+	
1 PLC ± -		APPLICATION SPEC	SIZE CAGE CODE DRAWING NO RESTRICTED TO	
2 PLC ± 0.13 [.005]		WEIGHT -	A2 00779 C=66425	
3 PLC ± -		CUSTOMER DRAWING	SCALE 8:1 SHEET 1 of 1 REV V	
4 PLC ± -				
ANGLES ± -				
FINISH				
SEE CALLOUTS		SEE TABLE		