

Brief Description

The ZSSC3026 is a sensor signal conditioner (SSC) integrated circuit for high-accuracy amplification and analog-to-digital conversion of a differential input signal. Developed for correction of resistive bridge sensors and optimized for high-resolution altimeter module applications, the ZSSC3026 can perform offset, span, and 1st and 2nd order temperature compensation of the measured signal. It can also provide a corrected temperature output measured with an internal sensor. The corrected measurement values are provided at the digital output pins, which can be configured as I²C™* (≤3.4MHz) or SPI (≤20MHz).

Digital compensation of the signal offset, sensitivity, temperature, and non-linearity is accomplished via an 18-bit internal digital signal processor (DSP) running a correction algorithm. Calibration coefficients are stored on-chip in a highly reliable, non-volatile, multiple-time programmable (MTP) memory. Programming the ZSSC3026 is simple via the serial interface. An internal charge pump provides the programming voltage. The interface is used for the PC-controlled calibration procedure, which programs the calibration coefficients in memory. The digital mating is fast and precise, eliminating the overhead normally associated with trimming external components and multi-pass calibration routines.

Features

- Flexible, programmable analog front-end design; up to 16-bit scalable, charge-balancing two-segment analog-to-digital converter (ADC)
- Fully programmable gain amplifier for optimizing sensor signals: gain range 14 to 72 (linear)
- Internal auto-compensated temperature sensor
- Digital compensation of individual sensor offset; 1st and 2nd order compensation of sensor gain
- Digital compensation of 1st and 2nd order temperature gain and offset drift
- Intelligent power management unit
- Layout customized for die-die bonding with sensor for high-density chip-on-board assembly
- Typical sensor elements can achieve accuracy of better than ±0.10% FSO @ -40 to 85°C

* I²C™ is a registered trademark of NXP.

Benefits

- Excellent for low-voltage and low-power battery applications
- Integrated 18-bit calibration math DSP
- Costs minimized via one-pass calibration
- No external trimming components required
- Highly integrated CMOS design

Physical Characteristics

- Supply voltage range: 1.8 to 3.6V
- Current consumption: 900µA (operating mode)
- Sleep State current: 50nA (typical)
- Temperature resolution: <0.003K/LSB
- Operation temperatures depending on part number: -40°C to +85°C
- Small die size
- Delivery options: die for wafer bonding, bumped die for Flip Chip, PQFN24

Typical Applications

The ZSSC3026 is designed for operation in calibrated resistive (e.g., pressure) sensor modules:

- Barometric altitude measurement for portable navigation
- Altitude measurement for emergency call systems and car navigation
- Inside hard disk pressure measurement
- Weather forecast
- Fan control

ZSSC3026 Application Example

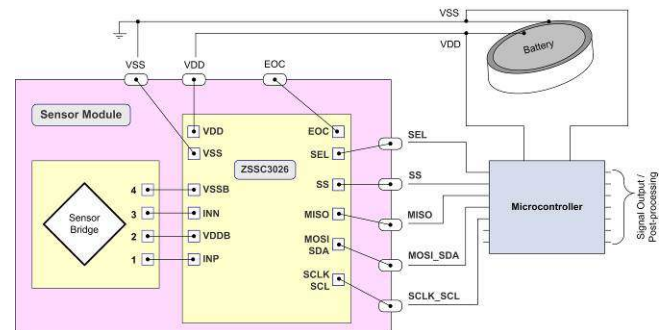

ZSSC3026 Block Diagram

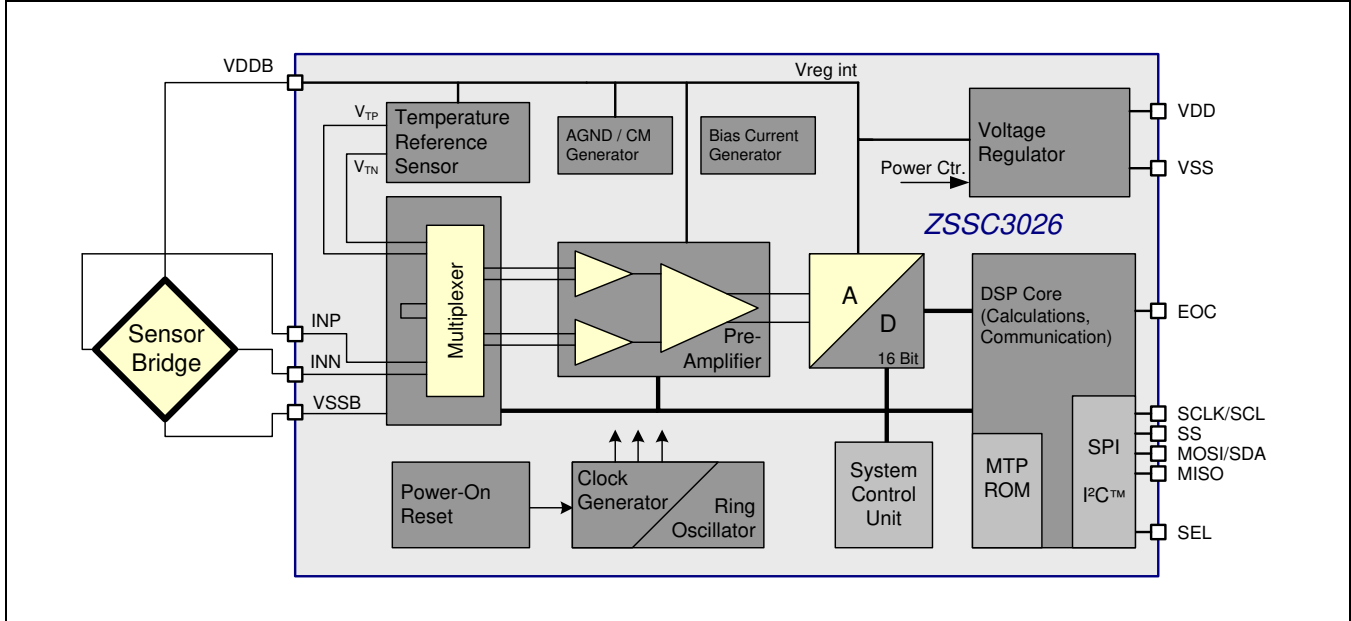

Ordering Information (Please contact IDT Sales for additional options)

Sales Code	Description	Package
ZSSC3026CC1B	ZSSC3026 Die — temperature range: -40°C to +85 °C, tested	Unsawn wafer (304µm)
ZSSC3026CI1B	ZSSC3026 Die — temperature range: -40°C to +85 °C; extended qualification: tested, 10 years MTP-data retention, HTOL tested	Unsawn wafer (304µm)
ZSSC3026KIT	Evaluation Kit for ZSSC30x6 Product Family; two circuit boards, cable, and 1 sample (Evaluation Software is downloadable from www.IDT.com/ZSSC3026)	Kit

Table of Contents

1	IC Characteristics	6
1.1.	Absolute Maximum Ratings	6
1.2.	Operating Conditions	6
1.3.	Electrical Parameters	7
1.4.	Power Supply Rejection Ratio (PSRR) vs. Frequency	10
2	Circuit Description	11
2.1.	Brief Description	11
2.2.	Signal Flow and Block Diagram.....	11
2.3.	Analog Front End.....	12
2.3.1.	Amplifier	12
2.3.2.	Analog-to-Digital Converter.....	14
2.3.3.	Temperature Measurement	18
2.3.4.	Bridge Supply.....	18
2.4.	Digital Section.....	18
2.4.1.	Digital Signal Processor (DSP) Core	18
2.4.2.	MTP Memory.....	18
2.4.3.	Clock Generator	19
2.4.4.	Power Supervision	19
2.4.5.	Interface	19
3	Functional Description.....	20
3.1.	Power Up.....	20
3.2.	Measurements	20
3.3.	Operational Modes	20
3.4.	Command Interpretation.....	23
3.4.1.	SPI/I ² C™ Commands	23
3.5.	Communication Interface.....	25
3.5.1.	Common Functionality	25
3.5.2.	SPI	27
3.5.3.	I ² C™.....	31
3.6.	Memory.....	32
3.6.1.	Programming Memory	33
3.6.2.	Memory Status Commands	33
3.6.3.	Memory Contents.....	34
3.7.	Calibration Sequence	40
3.7.1.	Calibration Step 1 – Assigning Unique Identification	40
3.7.2.	Calibration Step 2 – Data Collection	40
3.7.3.	Calibration Step 3 – Coefficient Calculations.....	41
3.8.	The Calibration Math	42
3.8.1.	Bridge Signal Compensation	42
3.8.2.	Temperature Signal Compensation	44
4	Die and Package Characteristics	45

4.1.	Die Pad Assignments	45
4.2.	Package (PQFN24) Properties	47
5	Quality and Reliability	49
6	Ordering Information	49
7	Related Documents	49
8	Glossary	50
9	Document Revision History	51

Table of Figures

Figure 2.1	ZSSC3026 Functional Block Diagram	11
Figure 2.2	ADC Offset	17
Figure 3.1	Operational Flow Chart: Power-Up	21
Figure 3.2	Operational Flow Chart: Command Mode and Normal Mode	22
Figure 3.3	SPI configuration CPHA=0	27
Figure 3.4	SPI Configuration CPHA=1	28
Figure 3.5	SPI Command Request	29
Figure 3.6	SPI Read Status	30
Figure 3.7	SPI Read Data	30
Figure 3.8	I ² C™ Command Request	31
Figure 3.9	I ² C™ Read Status	31
Figure 3.10	I ² C™ Read Data	32
Figure 3.11	Memory Program Operation	33
Figure 4.1	ZSSC3026 Pad Placement	45
Figure 4.2	General PQFN24 Package Dimensions	47

List of Tables

Table 1.1	Maximum Ratings	6
Table 1.2	Operating Conditions	6
Table 1.3	Constraints for VDD Power-On Reset	7
Table 1.4	Electrical Parameters.....	7
Table 2.1	Amplifier Gain: Stage 1	12
Table 2.2	Amplifier Gain: Stage 2.....	13
Table 2.3	Gain Polarity	13
Table 2.4	MSB/LSB Settings	14
Table 2.5	MSB/LSB Segmentation Settings for Temperature Measurement.....	14
Table 2.6	ADC Conversion Time for a Single A2D Conversion	15
Table 2.7	Typical Conversion Time vs. Noise Performance for 16-Bit Fully Conditioned Signal Results (AZBM, BM, AZTM, TM, and Digital SSC Correction).....	16
Table 2.8	ADC Offset Settings.....	17
Table 3.1	SPI/I2C Commands	23
Table 3.2	Get_Raw Commands	25
Table 3.3	General Status Byte.....	26
Table 3.4	Status Byte for Read Operations	26
Table 3.5	Status Byte for Write Operations	26
Table 3.6	Mode Status.....	26
Table 3.7	Memory Status Word	33
Table 3.8	MTP Memory Content Assignments.....	34
Table 4.1	Die Pad Assignments	46
Table 4.2	Physical Package Dimensions.....	47
Table 4.3	Pin Assignments PQFN24	48

1 IC Characteristics

1.1. Absolute Maximum Ratings

Note: The absolute maximum ratings are stress ratings only. The ZSSC3026 might not function or be operable above the recommended operating conditions. Stresses exceeding the absolute maximum ratings might also damage the device. In addition, extended exposure to stresses above the recommended operating conditions might affect device reliability. IDT does not recommend designing to the “Absolute Maximum Ratings.”

Table 1.1 Maximum Ratings

PARAMETER	SYMBOL	Min	TYP	MAX	UNITS
Voltage Reference	V_{SS}	0		0	V
Analog Supply Voltage	V_{DD}	-0.4		3.63	V
Voltage at all Analog and Digital IO Pins	V_{A_IO}, V_{D_IO}	-0.5		$V_{DD}+0.5$	V
Input Current into any Pin except SDA, CLK ¹⁾ and Supply Pins ²⁾	I_{in}	-100		100	mA
Electrostatic Discharge Tolerance – Human Body Model (HBM1) ³⁾	V_{HBM1}	4000		-	V
Storage Temperature	T_{STOR}	-50		125	°C

1) Latch-up current limit for CLK/SCLK and MOSI/SDA: ±70mA.
 2) Latch-up resistance; reference for pin is 0V.
 3) HBM1: C = 100pF charged to V_{HBM1} with resistor R = 1.5kΩ in series based on MIL 883, Method 3015.7. ESD protection referring to the Human Body Model is tested with devices in ceramic dual in-line packages (CDIP) during product qualification.

1.2. Operating Conditions

Note: Unless indicated otherwise, the reference from all voltage specifications in this section is V_{SS} .

Table 1.2 Operating Conditions

PARAMETER	SYMBOL	MIN	TYP	MAX	UNIT
Supply Voltage	V_{DD}	1.8	-	3.6	V
V_{DD} Rise Time	t_{VDD}			200	μs
Bridge Current ¹⁾	I_{VDDB}			1.8	mA
				16.5	
Operation Temperature Range	T_{AMB}	-40	-	85	°C
External Capacitance between VDDDB and VSS pins	CL	0.01		50	nF

1) The power supply rejection is reduced if the sensor bridge consumes a current in the range of $16.5mA > I_{VDDB} > 1.8mA$.

In order to achieve minimum current consumption in idle mode, a dynamic power-on-reset circuit is implemented. The V_{DD} low level and the subsequent rise time and V_{DD} rising slope must fulfill specific constraints to guarantee an overall ZSSC3026 reset. In general, lower V_{DD} low levels allow slower rising of the subsequent on-ramp of V_{DD} . The following table shows the relevant reset parameters and conditions. Other combinations might also be possible. For example, the reset trigger can be influenced by increasing the power-down time and relaxing the V_{DD} rising slope requirement.

Table 1.3 Constraints for VDD Power-On Reset

PARAMETER	SYMBOL	MIN	TYP	MAX	UNIT
Power Down Time (duration of VDD Low Level)	t_{SPIKE}	3	-	-	μs
V_{DD} Low Level	$V_{DD,LOW}$	0	-	0.2	V
V_{DD} Rising Slope	SR_{VDD}	10	-	-	V/ms

1.3. Electrical Parameters

All parameter values are valid only under specified operating conditions. All voltages are referenced to V_{SS} .

Table 1.4 Electrical Parameters

PARAMETER	SYMBOL	CONDITIONS/COMMENTS	MIN	TYP	MAX	UNIT
SUPPLY						
Bridge Supply Voltage, ADC Reference Voltage	V_{DDB}	Internally generated	1.60	1.67	1.74	V
Current Consumption	I_{VDD}	Active State, average		900	1500	μA
		Sleep State, idle current, <85°C		20	250	nA
		Sleep State, idle current, <125°C		50	950	nA
Power Supply Rejection (see section 1.4) $20 \cdot \log_{10}(V_{DD}/V_{DDB})$	PSR_{VDD}	$V_{DD} = 1.8V$	17			dB
		$V_{DD} = 2V$	32			dB
Memory Program Voltage	$V_{DD,prog}$	Required voltage level at VDD pin	2.9		3.6	V
Mean Program Current	$I_{VDD,Prog}$	Mean current consumption during MTP programming cycle at VDD	6			mA
Peak Program Current	$I_{prog,max}$	MTP Program at VDD pin, dynamic switch-on current draw			20	mA

PARAMETER	SYMBOL	CONDITIONS/COMMENTS	MIN	TYP	MAX	UNIT
ANALOG-TO-DIGITAL CONVERTER (ADC)						
Resolution	r_{ADC}		10		16	Bit
ADC Clock Frequency	f_{ADC}	Internal ADC clock	0.925	1	1.12	MHz
Reference Voltage n	V_{refn}			$V_{DDB} * 0.03$		
Reference Voltage p	V_{refp}			$V_{DDB} * 0.97$		
Offset	A2D_Offset	8-step programmable offset	1/16		8/16	
Integral Nonlinearity (INL)	INL _{ADC}	Based on ideal slope	-4	-	+4	LSB
Differential Nonlinearity	DNL _{ADC}	Tested / verified within design	-1	-	+1	LSB
Conversion Rate, 16-bit Single	$f_{s,raw}$	Conversions per second for single 16-bit analog-to-digital conversion	6	-	355	Hz
AMPLIFIER						
Gain	G_{amp}	32 steps	13.2		72	
Gain Error	G_{err}	Referenced to nominal gain	-1.5	-	1.5	%
SENSOR SIGNAL CONDITIONING PERFORMANCE						
ZSSC3026 Accuracy Error	Err _{A,IC}	Accuracy error with sensor that is ideally linear with respect to temperature and measurand			0.01	%FSO
Conversion Rate, 16-bit with Sensor Signal Conditioning	$f_{s,SSC}$	Conversion per second for fully corrected 16-bit measurement	3		175	Hz
INPUT						
Input Voltage Range	V_{INP}, V_{INN}	Input voltage range at INP and INN pins	0.65		1.05	V
Bridge Resistance	R_{BR}	Full power supply disturbance rejection (PSRR) capabilities	1	10	50	kΩ
		Reduced PSRR, but still full functionality	100		999	Ω

* Percentage referenced to maximum full-scale output (FSO); e.g., for 16-bit measurements:
 $Err_{A,IC} [\%FSO] = 100 * \text{MAX}\{ |ADC_{meas} - ADC_{ideal}| \} / 2^{16}$

PARAMETER	SYMBOL	CONDITIONS/COMMENTS	MIN	TYP	MAX	UNIT
POWER UP						
Start-up Time	t_{STA1}	V_{DD} ramp up to interface communication			1	ms
	t_{STA2}	V_{DD} ramp up to analog operation			2.5	ms
Wake-up Time	t_{WUP1}	Sleep to Active State interface communication			0.5	ms
	t_{WUP2}	Sleep to Active State analog operation			2	ms
OSCILLATOR						
Internal Oscillator Frequency	f_{CLK}		3.6	4	4.4	MHz
INTERNAL TEMPERATURE SENSOR						
Temperature Resolution		-40°C to +85°C		0.003		K/LSB
INTERFACE and MEMORY						
SPI Clock Frequency	$f_{C,SPI}$	Maximum capacitance at MISO-line: 40pF @ $V_{DD}=1.8V$			20	MHz
I ² C™ Clock Frequency	$f_{C,I2C}$				3.4	MHz
Program Time	t_{prog}	MTP programming time per register	500		600	μs
Data Retention	t_{RET_MTP}	For extended qualification version ZSSC3026C _{lxx} , 1000h @ 125°C	10*			a

* With maximum ambient temperature of 125°C.

1.4. Power Supply Rejection Ratio (PSRR) vs. Frequency

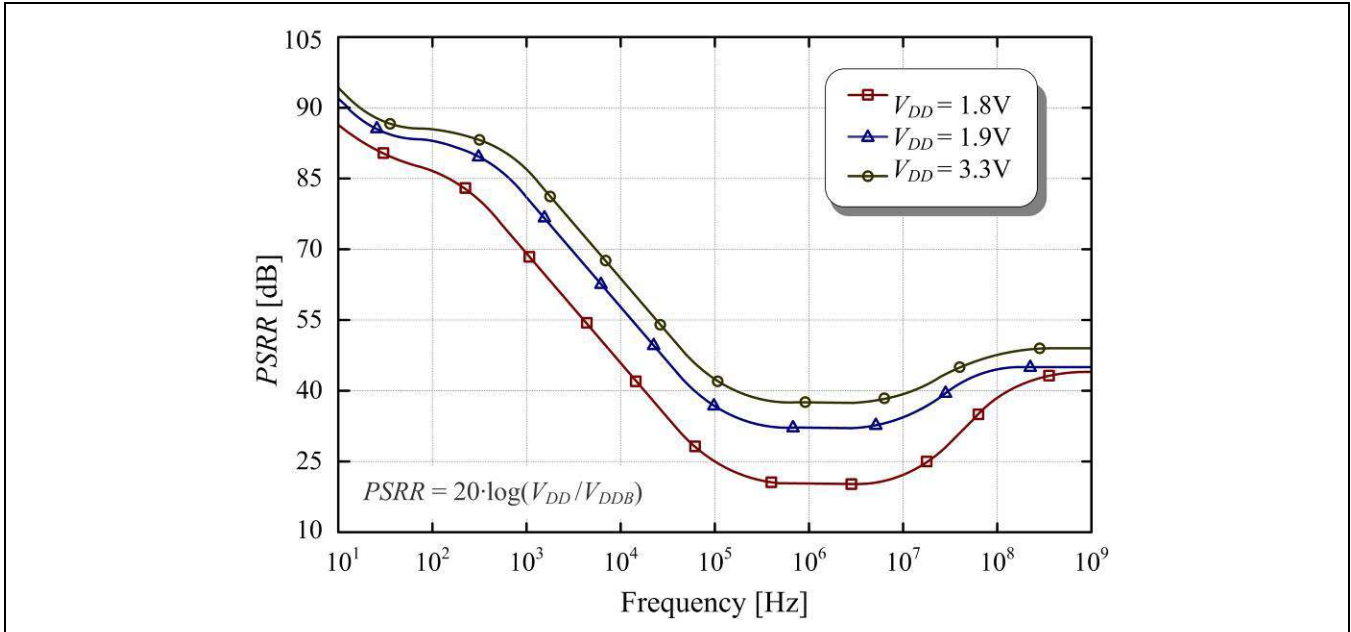

The amplifier consists of two stages with programmable gain values. The 1/f noise and inherent offset are suppressed by auto-zero and chopper-stabilizer techniques. This auto-zero sequence is performed before each bridge sensor and temperature measurement to compensate for the inherent offset of the amplifier.

The ZSSC3026 employs a charge-balancing analog-to-digital converter (ADC) based on switched-capacitor technique with inherent low-pass behavior and noise suppression. The programmable resolution from 10 to 16 bit provides flexibility for adapting the conversion characteristics. To improve power supply noise suppression, the ADC uses the bridge supply V_{DDB} as its reference voltage.

The remaining IC-internal offset and the sensor element offset; i.e., the overall system offset for the amplifier and ADC can be canceled by an offset and auto-zero measurement, respectively.

The DSP accomplishes the auto-zero, span, and 1st and 2nd order temperature compensation of the measured bridge signal. The correction coefficients are stored in the MTP memory.

The ZSSC3026 supports SPI and I²C™ interface communication for controlling the ZSSC3026, configuration, and measurement result output.

2.3. Analog Front End

2.3.1. Amplifier

The amplifier has a differential architecture, and it consists of two stages. The amplification of each stage and the sensor bridge gain polarity are programmable via settings in the Measurement Configuration Register (*BM_config*; see section 3.6.3) in the MTP memory (see section 2.4.2).

The first five bits of *BM_config* are the programmable gain settings *Gain_stage1* and *Gain_stage2*. The options for the programmable gain settings are listed in Table 2.1 and Table 2.2.

Table 2.1 Amplifier Gain: Stage 1

<i>Gain_stage1</i>		
<i>BM_config</i> [1] Bit 1G1	<i>BM_config</i> [0] Bit G0	Stage 1 Gain Setting
0	0	12
0	1	20
1	0	30
1	1	40

Table 2.2 Amplifier Gain: Stage 2

<i>Gain_stage2</i>			
<i>BM_config</i> [4] Bit G4	<i>BM_config</i> [3] Bit G3	<i>BM_config</i> [2] Bit G2	Stage 2 Gain Setting
0	0	0	1.1
0	0	1	1.2
0	1	0	1.3
0	1	1	1.4
1	0	0	1.5
1	0	1	1.6
1	1	0	1.7
1	1	1	1.8

If needed, the polarity of the sensor bridge gain can be reversed by setting the *Gain_Polarity* bit, which is bit 5 in the *BM_config* register (see section 3.6.3). Changing the gain polarity is achieved by inverting the chopper clock. Table 2.3 gives the settings for the *Gain_Polarity* bit. This feature enables connecting a sensor to the ZSSC3026 with swapped input signals at INN and INP; e.g., to avoid crossing wires for the final sensor module’s assembly.

Table 2.3 Gain Polarity

<i>Gain_Polarity</i> Bit (<i>BM_config</i> [5])	Gain	Setting Description
0	+1	No polarity change.
1	-1	Gain polarity is inverted.

The inherent amplifier offset is suppressed by means of auto-zero and chopper techniques.

The optimal gain (and offset) setup for a specific sensor element can be determined by these steps:

- 1) Collect sensor element’s characteristic, statistical data (across temperature, ambient sensor parameters, and production tolerances):
 - a. Minimum differential output voltage: V_{min}
 - b. Maximum differential output voltage: V_{max}

Remark: The best possible setup can only be determined if the absolute value of V_{max} is higher than the absolute value of V_{min} . If this is not the case, the gain polarity should be swapped.

- 2) If V_{min} and V_{max} have different signs (normally, V_{max} is positive and V_{min} is negative), then the required ADC offset shift can be selected using the ratio: $Ratio_{Offset} = |V_{min}| / (V_{max} - V_{min})$
 In this case, the respective offset setup (A2D_offset) is the nearest integer of multiples of 1/16 in the range of 1/16 to 8/16 (see Table 2.8): $A2D_offset = Round_to_x16^{th}\{Ratio_{Offset}\}$.

3) Determine which of the two following cases is valid.

a. If $\text{Ratio}_{\text{Offset}} - \text{A2D_offset} \leq 0$ then calculate

$$\text{Theoretical optimum gain: } \text{Gain}_{\text{opt}} = (1 - \text{A2D_offset}) * V_{\text{ref}} / V_{\text{max}}$$

b. If $\text{Ratio}_{\text{Offset}} - \text{A2D_offset} > 0$ then calculate

$$\text{Theoretical optimum gain: } \text{Gain}_{\text{opt}} = \text{A2D_offset} * V_{\text{ref}} / |V_{\text{min}}|$$

$$\text{with } V_{\text{ref}} = V_{\text{refp}} - V_{\text{refn}} = 0.94 * V_{\text{DDB,min}} \approx 1.5\text{V}$$

Then select the setup gain ($\text{Gain}_{\text{setup}}$) as nearest gain to Gain_{opt} , whereas $\text{Gain}_{\text{setup}} \leq \text{Gain}_{\text{opt}}$.

2.3.2. Analog-to-Digital Converter

A second-order charge-balancing analog-to-digital converter (ADC) is used to convert the amplifier signal. To allow optimizing the trade-off between conversion time and resolution, the conversion is split into a MSB coarse conversion and an LSB fine conversion.

The final ADC resolution is determined by MSB + LSB. For the bridge measurement, the MSB-LSB segmentation is programmable via the *Msb* and *Lsb* settings in the *BM_config* register (10_{HEX}; see section 3.6.3) stored in the MTP memory (see section 2.4.2). For the temperature measurement, the MSB-LSB segmentation is programmable via the *Temp_ADC* settings in the *BM_config* register.

The conversion time is proportional to $2^{\text{MSB}} + 2^{\text{LSB}}$. During the MSB coarse conversion, the ADC input signal is sampled and integrated 2^{MSB} times, resulting in inherent low-pass behavior and noise suppression. The longer the MSB coarse conversion is, the better the noise suppression. Possible settings are listed below in Table 2.4.

Table 2.4 MSB/LSB Settings

<i>Msb</i> Setup Bits [7:6] in <i>BM_config</i>	Number of MSB Coarse Conversion Bits	<i>Lsb</i> Setup Bits [9:8] in <i>BM_config</i>	Number of LSB Fine Conversion Bits
00 _{BIN}	10	00 _{BIN}	0
01 _{BIN}	12	01 _{BIN}	2
10 _{BIN}	14	10 _{BIN}	4
11 _{BIN}	16	11 _{BIN}	6

Table 2.5 MSB/LSB Segmentation Settings for Temperature Measurement

<i>Temp_ADC</i> Setup Bits [14:13] in <i>BM_config</i>	Number of MSB Coarse Conversion Bits	Number of LSB Fine Conversion Bits
00 _{BIN}	Setup according to IDT configuration in reserved memory (recommended setup for best performance and speed trade-off)	
01 _{BIN}	16	0
10 _{BIN}	10	6
11 _{BIN}	12	4

Useful MSB/LSB setups are with $LSB = 0$ (i.e., MSB-only conversions) or the combinations that result in $MSB + LSB \leq 16$. Resolutions beyond 16-bit mainly digitize the collected front-end noise and typically do not improve the system performance. MSB/LSB segmentations with $LSB > MSB$ are also not useful because typically the resolution remains the same as with the inverse MSB/LSB segmentation but the noise performance becomes significantly worse yet the required conversion time stays the same.

The ADC conversion times for different MSB/LSB settings are listed in Table 2.6. Settings shown with pink shading are preferred settings with the best balance between conversion time and noise.

Table 2.6 ADC Conversion Time for a Single A2D Conversion

MSB Setting (Bits)	LSB Setting (Bits)	Bridge or Temperature Measurement Conversion Time in μs (typical)
10	0	1169
12	0	4625
14	0	18449
16	0	73745
10	2	1176
12	2	4632
14	2	18456
10	4	1200
12	4	4656
10	6	1296

Table 2.7 Typical Conversion Time vs. Noise Performance for 16-Bit Fully Conditioned Signal Results (AZBM, BM, AZTM, TM, and Digital SSC Correction)

Note: The pink shading indicates IDT's recommended ADC segmentation for temperature sensor measurement.

ADC Segmentation: Temperature Sensor (MSB/LSB)	ADC Segmentation: Bridge Sensor (MSB/LSB)	Typical Measurement Duration, MEASURE (A _{CHEX}) (ms)	Typical 3-Sigma Noise for SSC-corrected Output ¹⁾ (counts)
10 / 6	10 / 6	5.8	8.6
10 / 6	12 / 4	13.2	6.4
10 / 6	14 / 2	43.0	5.8
10 / 6	16 / 0	164.1	5.6
12 / 4	10 / 6	13.2	8.4
12 / 4	12 / 4	20.5	6.4
12 / 4	14 / 2	50.5	5.6
12 / 4	16 / 0	170.3	5.1
14 / 2	10 / 6	43.0	7.6
14 / 2	12 / 4	50.5	5.9
14 / 2	14 / 2	80.7	4.4
14 / 2	16 / 0	200.3	4.4
16 / 0	10 / 6	162.6	6.9
16 / 0	12 / 4	170.3	5.4
16 / 0	14 / 2	200.3	4.1
16 / 0	16 / 0	319.5	4.0

1) Reference noise values obtained with this setup: 13.7kΩ sensor bridge, 25°C, Gain=64, A2D_offset shift=-1/16 through 15/16, VDD=1.8V.

The ADC offset is programmable in eight steps so that the ADC input voltage range can be adapted to the voltage range at the input pins INP and INN. Possible ADC input voltages are shown in Figure 2.2, where $V_{AGND} = V_{DDB}/2$. The ADC offset is controlled by the *A2D_Offset* setting in the Measurement Configuration Register (*BM_config*: 10_{HEX}; see section 3.6.3) in the MTP memory (see section 2.4.2). The ADC offset settings are listed in Table 2.8. See Table 1.4 for typical values for V_{refn} and V_{refp} .

Figure 2.2 ADC Offset

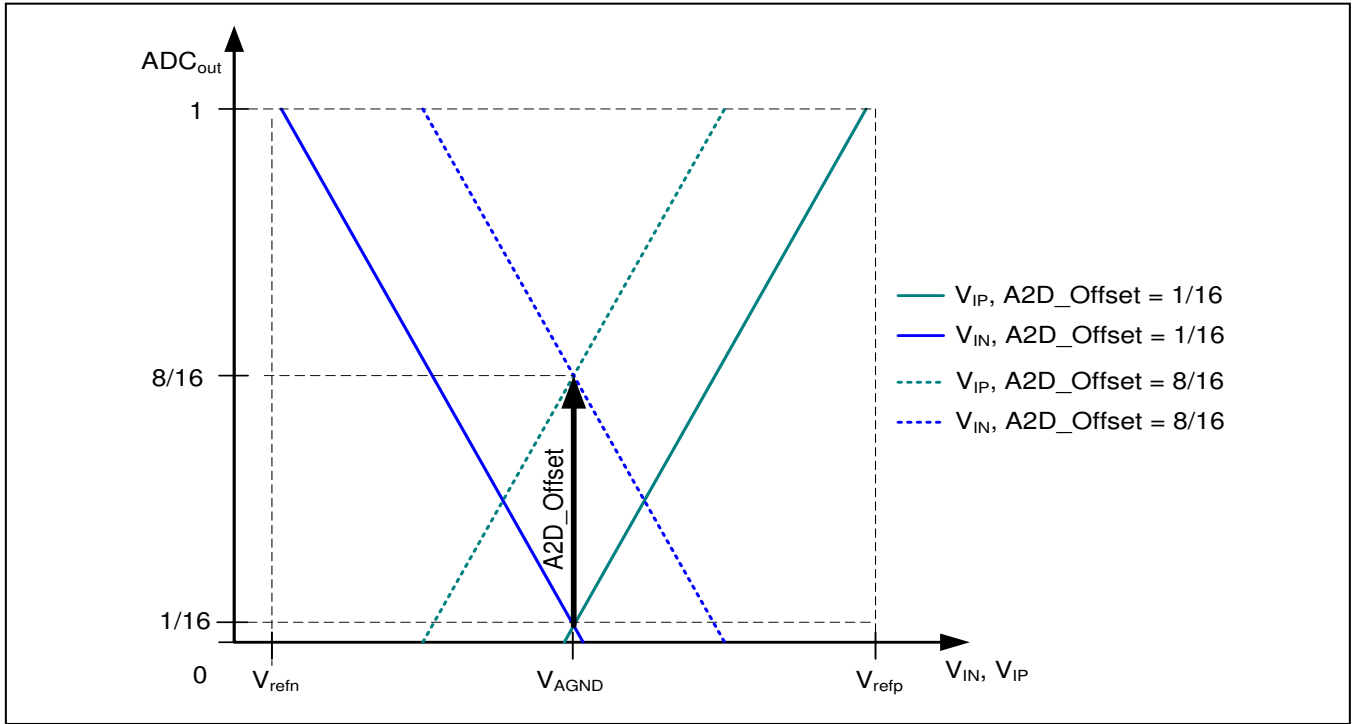

Table 2.8 ADC Offset Settings

Z2	Z1	Z0	ADC Differential Input Range/ V_{ref} Where $V_{ref} = V_{refp} - V_{refn}$	A2D_Offset
0	0	0	-1/16 to 15/16	1/16
0	0	1	-2/16 to 14/16	2/16
0	1	0	-3/16 to 13/16	3/16
0	1	1	-4/16 to 12/16	4/16
1	0	0	-5/16 to 11/16	5/16
1	0	1	-6/16 to 10/16	6/16
1	1	0	-7/16 to 9/16	7/16
1	1	1	-8/16 to 8/16	8/16

2.3.3. Temperature Measurement

The ZSSC3026 provides an internal resistive temperature sensor measurement to allow compensation for temperature effects. See section 1.3 for the temperature sensor resolution. The temperature output signal is a differential voltage that is adapted by the amplifier for the ADC input.

For temperature measurements, the ADC offset and amplifier gain setting are defined by IDT. The ADC MSB/LSB segmentation is programmable by the user for optimizing resolution or conversion time (see section 2.3.2).

2.3.4. Bridge Supply

The ZSSC3026 provides dedicated bridge supply pins V_{DDB} and V_{SSB}. The ADC reference voltages for the sensor bridge measurement are derived from these internal voltages so that bridge supply disturbances are suppressed. The current drive ability of V_{DDB} is limited (see I_{V_{DDB}} in section 1.2).

2.4. Digital Section

2.4.1. Digital Signal Processor (DSP) Core

The DSP Core block performs the algorithm for correcting the sensor signal. The resulting coefficients are stored in the MTP memory. When the measurement results are available, the "end of conversion" signal is set at the EOC pin. The internal EOC information is valid only if both the measurement and calculation have been completed.

2.4.2. MTP Memory

The ZSSC3026's memory is designed with an OTP (one-time programmable) structure. The memory is organized in 4 one-time programmable pages. When data in the currently valid memory page is to be updated, normally a new page must be selected by increasing the page counter and the whole memory contents must be written in its updated version. The user has access to a 24x16-bit storage area for values such as calibration coefficients. Dedicated calibration values are stored in an area not accessible to the user. The required programming voltage is generated internally in the ZSSC3026 whereas increased ZSSC3026 power supply requirements must be fulfilled during programming (see "Memory Programming Voltage" in section 1.3). There is no over-write or erase function for the MTP memory.

The physical memory function is such that each single bit that has not yet been set to 1 (i.e., remains 0) can still be changed to 1, so it is possible to (partially) re-program an MTP register as shown in the following example:

- Assume MTP-address 11_{HEX} was written with 8421_{HEX} which is 1000 0100 0010 0001_{BIN}
- As an example, changing the register contents to A6A7_{HEX} (i.e., 1010 0110 1010 0111_{binary}) can be achieved by either writing A6A7_{HEX} (any already written bit will be ignored automatically) or just writing the difference compared to 8421_{HEX}, which is 2286_{HEX}.

The contents of a re-written register can generally be determined by

$$\text{content}_{\text{Register}} = \text{content}_{\text{old}} (\text{BITWISE_OR}) \text{content}_{\text{new}}$$

If content_{Register} equals content_{new}, a re-write is possible; e.g. this is not the case for content_{old} = FFFF_{HEX} and content_{new} ≠ FFFF_{HEX}. Depending on the former and the newly intended MTP address and register contents, a re-programming could be possible.

2.4.3. Clock Generator

The clock generator, implemented as a ring oscillator, provides a 4MHz clock signal. The frequency is trimmed during production test.

2.4.4. Power Supervision

The power supervision block, a section of the voltage regulator combined with the digital section, monitors all power supplies to ensure a defined reset of all digital blocks during power-up or power supply interruptions.

2.4.5. Interface

The ZSSC3026 can communicate with the user's PC via an SPI or I²C™ interface*. The interface type is selectable via the voltage level on the SEL pin:

- SEL = 0 → SPI Mode
- SEL = 1 → I²C™ Mode

If the SEL pin is not connected, I²C™ communication will be selected (ZSSC3026-internal pull-up at SEL pin). The SPI-specific pins (SS, MISO) do not need to be connected at all for I²C™ operation.

To also provide interface accessibility in Sleep State (all features inactive except for the digital interface logic), the interface circuitry is directly supplied by VDD.

*. Functional I²C™ interface properties correspond to the NXP I²C™ bus specification revision 0.3 (June 2009).

3 Functional Description

3.1 Power Up

Specifications for this section are given in sections 1.2 and 1.3. On power-up, the ZSSC3026 communication interface is able to receive the first command after a time t_{STA1} from when the VDD supply is within operating specifications. The ZSSC3026 can begin the first measurement after a time of t_{STA2} from when the VDD supply is operational. The wake-up time from Sleep State to Active State (see section 3.3) after receiving the activating command is defined as t_{WUP1} and t_{WUP2} . In Command Mode, subsequent commands can be sent after t_{WUP1} . The first measurement starts after t_{WUP2} if measurement request was sent.

3.2 Measurements

Available measurement procedures are

- AZBM: auto-zero bridge measurement
- BM: bridge measurement
- AZTM: auto-zero temperature measurement
- TM: temperature measurement

AZBM: The configuration for bridge measurements is loaded. The Multiplexer connects the amplifier input to the AGND analog ground reference. An analog-to-digital conversion is performed so that the inherent system offset for the bridge configuration is converted by the ADC to a 16-bit digital word.

BM: The configuration for bridge measurements is loaded. The Multiplexer connects the amplifier input to the bridge pins INP and INN. An analog-to-digital conversion is performed. The result is a 16-bit digital word.

AZTM: The configuration for temperature measurements is loaded. The Multiplexer connects the Amplifier input to AGND. An analog-to-digital conversion is performed so that the inherent system offset for the temperature configuration is converted by the ADC to a 16-bit digital word.

TM: The configuration for temperature measurements is loaded. The Multiplexer connects the Amplifier input to the internal temperature sensor. An analog-to-digital conversion is performed. The result is a 16-bit digital word.

The typical application's measurement cycle is a complete SSC measurement (using the command AC_{HEX}) with AZBM, BM, AZTM, and TM followed by a signal correction calculation.

3.3 Operational Modes

Figure 3.1 illustrates the ZSSC3026 power-up sequence and subsequent operation depending on the selected interface communication mode (I^2C^{TM} or SPI). With either interface, after the voltage regulators are switched on, the ZSSC3026's low voltage section (LV) is active while the related interface configuration information is read from memory. Then the LV section is switched off, the ZSSC3026 goes into Sleep State, and the interface is ready to receive commands. The interface is always powered by V_{DD} , so it is referred to as the high voltage section (HV).

Figure 3.2 shows the ZSSC3026 operation in Normal Mode and Command Mode including when the LV and HV sections are active as indicated by the color legend. The Normal Mode automatically returns to Sleep State after executing the requested measurements. In Command Mode, the ZSSC3026 remains active if a dedicated command (Start_NOM) was sent, which is helpful during calibration. Command Mode can only be entered if Start_CM is the very first command after POR.

Figure 3.1 Operational Flow Chart: Power-Up

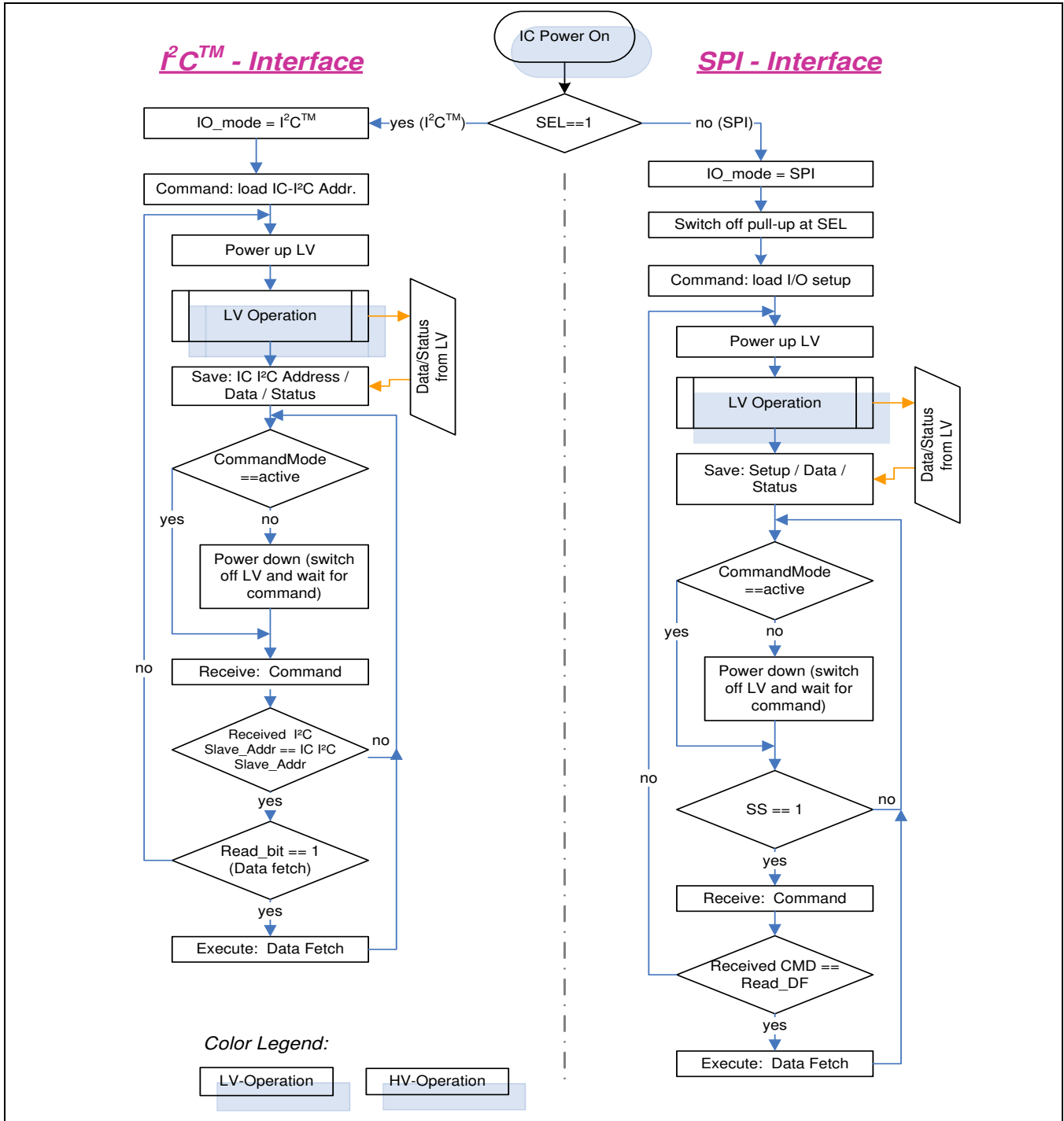
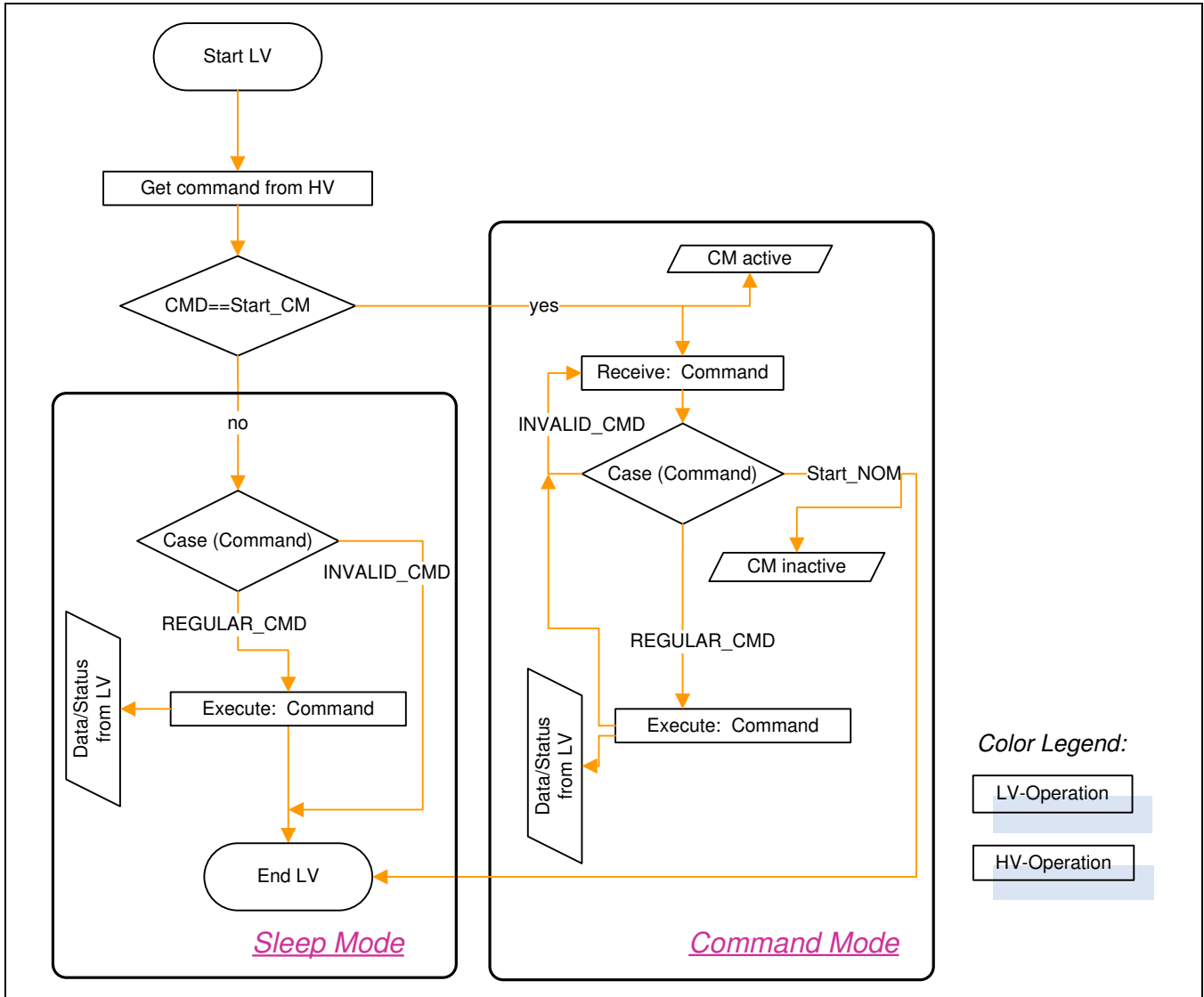

Figure 3.2 Operational Flow Chart: Command Mode and Normal Mode



3.4. Command Interpretation

3.4.1. SPI/I²C™ Commands

The user-accessible section of memory includes addresses 00_{HEX} through 17_{HEX} in the OTP memory that is designated by the user memory page pointer. Because each of the four OTP memory pages cannot be rewritten or erased, the memory page pointer must be incremented to the next OTP memory page in order to write to memory again (see Table 3.1 for the command). After all four user-accessible OTP memory pages have been used, further write operations are not possible and the “Memory Full” bit is returned as set in the status byte after write operations (see section 3.5.1).

The SPI/I²C™ commands supported by the ZSSC3026 are listed in Table 3.1. The command to read an address in the user memory is the same as its address. The command to read the 16-bit memory status of the data at an address in user memory is the address plus 20_{HEX}. The command to write to an address in user memory is the address plus 40_{HEX}.

There is a IDT-reserved section of memory, which can be read but not over-written by the user.

Table 3.1 SPI/I²C Commands

Note: Every return starts with a status byte followed by the data word as described in section 3.5.1.

Command (Byte)	Returns	Description	Normal Mode	Command Mode
00 _{HEX} to 17 _{HEX}	16-bit user data	Read data in the user memory address (00 _{HEX} to 17 _{HEX}) matching the command (might not be using all addresses).	Yes	Yes
20 _{HEX} to 37 _{HEX}	16-bit user memory status	Read memory status for address specified by command minus 20 _{HEX} (addresses 00 _{HEX} to 17 _{HEX} respectively; see section 3.6.2 for a description of the memory status).	Yes	Yes
40 _{HEX} to 57 _{HEX} followed by data (0000 _{HEX} to FFFF _{HEX})	—	Write data to user memory at address specified by command minus 40 _{HEX} (addresses 00 _{HEX} to 17 _{HEX} respectively; might not be using all addresses).	No	Yes
70 _{HEX} to 7E _{HEX}	16-bit IDT-reserved memory data	Read data in IDT-reserved memory at address specified by command minus 70 _{HEX} (second set of addresses 00 _{HEX} to 0E _{HEX} respectively).	No	Yes
80 _{HEX} to 8E _{HEX}	16-bit IDT-reserved memory status	Read memory status bytes for IDT-reserved memory data at address specified by command minus 80 _{HEX} (second set of addresses 00 _{HEX} to 0E _{HEX} respectively; see section 3.6.2 for a description of the memory status bytes).	No	Yes
5E _{HEX}	—	Increment user memory page pointer.	No	Yes
A0 _{HEX} to A7 _{HEX} followed by XXXX _{HEX}	16-bit wide raw data	Get_Raw This command can be used to perform a measurement and write the raw ADC data into the output register. The LSB of the command determines how the AFE	Yes	Yes

Command (Byte)	Returns	Description	Normal Mode	Command Mode
(see Table 3.2)		configuration register is loaded for the Get_Raw measurement (see Table 3.2).		
A8 _{HEX}	—	Start_NOM Exit Command Mode and transition to Normal Mode.	No	Yes
A9 _{HEX}	—	Start_CM Exit Normal Mode and transition to Command Mode.	Yes	No
AA _{HEX}	—	Write_ChecksumC If not yet written, the checksum for the valid user MTP page is calculated and written to MTP.	No	Yes
AC _{HEX}	16-bit fully corrected bridge measurement data + 16-bit corrected internal temperature	Measure Triggers full measurement cycle (AZBM, BM, AZTM, and TM, as described in section 3.2) and calculation and storage of data in interface (configurations from MTP).	Yes	Yes
FX _{HEX}	Status followed by last data	NOP Only valid for SPI (see section 3.5.1).	Yes	Yes

Table 3.2 Get_Raw Commands

Command	Measurement	AFE Configuration Register
A0 _{HEX} + 0000 _{HEX}	BM – Bridge Measurement	<i>BM_config</i>
A1 _{HEX} + ssss _{HEX}	BM – Bridge Measurement	ssss is the user's configuration setting for the measurement provided via the interface. The format and purpose of configuration bits must be according to the definitions for <i>BM_config</i> .
A2 _{HEX} + 0000 _{HEX}	BM-AZBM – Auto-Zero corrected Bridge Measurement ¹⁾	<i>BM_config</i>
A3 _{HEX} + ssss _{HEX}	BM-AZBM – Auto-Zero corrected Bridge Measurement ²⁾	ssss is the user's configuration setting for the measurement provided via the interface. The format and purpose of configuration bits must be according to the definitions for <i>BM_config</i> .
A4 _{HEX} + 0000 _{HEX}	TM – Temperature Measurement	IDT-defined register.
A5 _{HEX} + ssss _{HEX}	TM – Temperature Measurement	ssss is the user's configuration setting for the measurement provided via the interface. The format and purpose of configuration bits must be according to the definitions for <i>BM_config</i> being valid for temperature measurement in this case (bits [15:13] will be ignored).
A6 _{HEX} + 0000 _{HEX}	TM-AZTM – Auto-Zero corrected Temperature Measurement ¹⁾	IDT-defined register.
A7 _{HEX} + ssss _{HEX}	TM-AZTM – Auto-Zero corrected Temperature Measurement ²⁾	ssss is the user's configuration setting for the measurement provided via the interface. The format and purpose of configuration bits must be according to the definitions for <i>BM_config</i> being valid for temperature measurement in this case (bits [15:13] will be ignored).
<p>1) Recommended for raw data collection during calibration coefficient determination using pre-programmed (in MTP) measurement setups.</p> <p>2) Recommended for raw data collection during calibration coefficient determination using un-programmed (not in MTP), external measurement setups; e.g. for evaluation purposes.</p>		

3.5. Communication Interface

3.5.1. Common Functionality

Commands are handled by the command interpreter in the LV section. Commands which need additional data are not treated differently than other commands because the HV interface is able to buffer the command and all data that belongs to the command, and the command interpreter is activated as soon as a command byte is received.

Every response starts with a status byte followed by the data word. The data word depends on the previous command. It is possible to read the same data more than once if the read request is repeated (I²C™) or a NOP command is sent (SPI). If the next command is not a read request (I²C™) or a NOP (SPI), it invalidates any previous data.

The status byte contains the following bits (see Table 3.3, Table 3.4, and Table 3.5 for sequence):

- Power indication (bit 6): 1 if the device is powered (V_{DDB} on); 0 if not powered. This is needed for SPI Mode where the master reads all zeros if the device is not powered or in power-on reset (POR).
- Busy indication (bit 5): 1 if the device is busy, which indicates that the data for the last command is not available yet. No new commands are processed if the device is busy.
- Actual ZSSC3026 mode (bits 4:3): 00 = Normal Mode; 01 = Command Mode; 1X = IDT-reserved.
- Memory integrity/error flag (bit 2): 0 if integrity test passed, 1 if test failed. This bit indicates whether the checksum-based integrity check passed or failed. Correctable errors are not reported but can be queried with the memory status commands (see section 3.6.2). The memory error status bit is calculated only during the power-up sequence, so a newly written CRC will only be used for memory verification and status update after a subsequent ZSSC3026 power-on reset (POR).
- Data transfer/correction (bit 1): If the last command was a memory write, this bit is 0 if the last memory write was successful (memory not full yet); otherwise it is 1 (e.g., page increase but being already on last MTP page). If the last command was a memory read, this bit is 1 if the data was corrected.

Table 3.3 General Status Byte

Bit	7	6	5	4	3	2	1	0
Meaning	0	Powered?	Busy?	Mode		Memory error?	Internal data transfer	Special

Table 3.4 Status Byte for Read Operations

Bit	7	6	5	4	3	2	1	0
Meaning	0	Powered?	Busy?	Mode		Memory error?	Data corrected?	ALU saturation?

Table 3.5 Status Byte for Write Operations

Bit	7	6	5	4	3	2	1	0
Meaning	0	Powered?	Busy?	Mode		Memory error?	Memory full? ⇔ MTP write reject?	Don't care

Table 3.6 Mode Status

Status [4:3]	Mode
00	Normal Mode
01	Command Mode
10	IDT-Reserved
11	Command Mode and Reserved

Further status information is provided by the EOC pin. The EOC pin is set high when a measurement and calculation have been completed.

3.5.2. SPI

The SPI Mode is available when the SEL pin = 0. The polarity and phase of the SPI clock are programmable via the CKP_CKE setting in address 02_{HEX} as described in Table 3.8. CKP_CKE is two bits: CPHA (bit 10), which selects which edge of SCLK latches data, and CPOL (bit 11), which indicates whether SCLK is high or low when it is idle. The polarity of the SS signal and pin are programmable via the SS_polarity setting (bit 9). The different combinations of polarity and phase are illustrated in the figures below.

Figure 3.3 SPI configuration CPHA=0

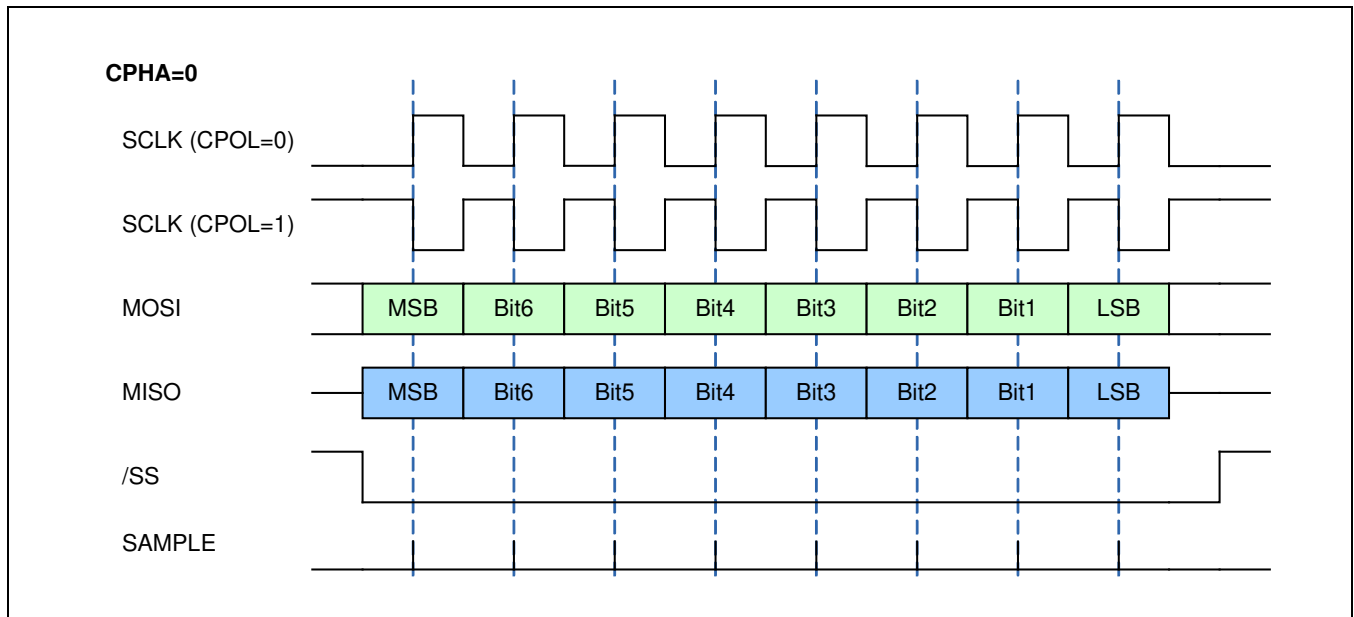
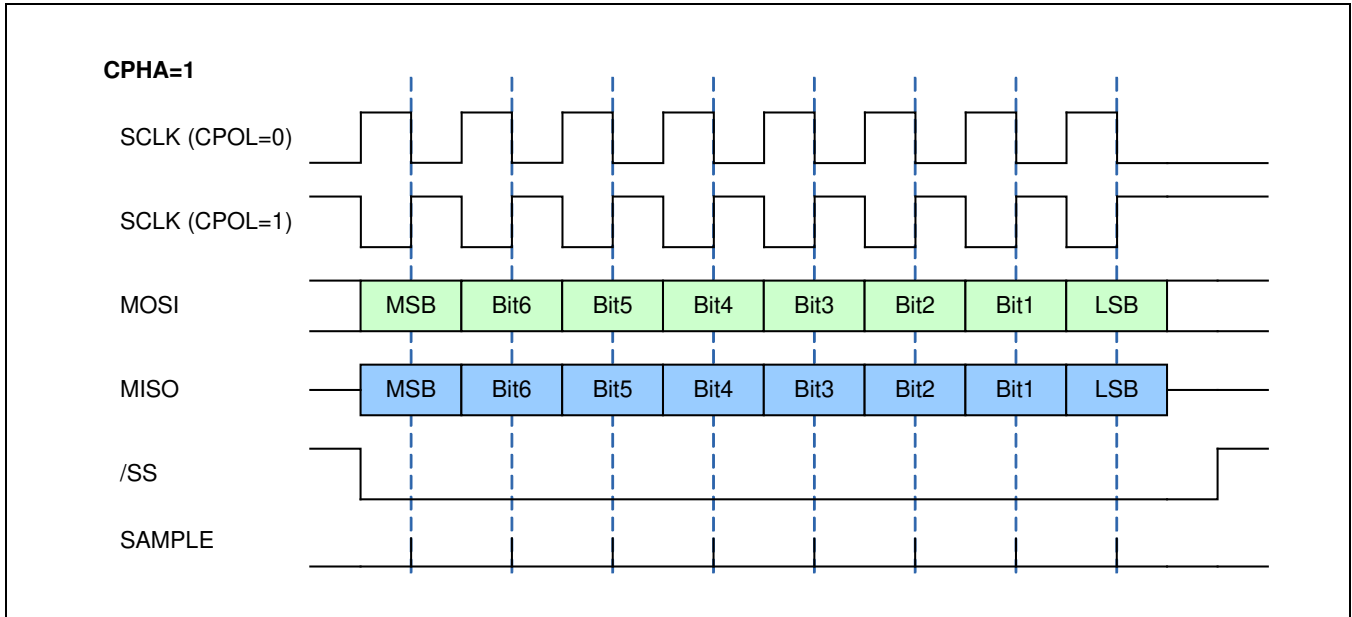

Figure 3.4 SPI Configuration CPHA=1



In SPI mode, each command except NOP is started as shown in Figure 3.5. After the execution of a command (busy = 0), the expected data can be read as illustrated in

Figure 3.6 or if no data are returned by the command, the next command can be send. The status can be read at any time with the NOP command (see Figure 3.7).

Figure 3.5 SPI Command Request

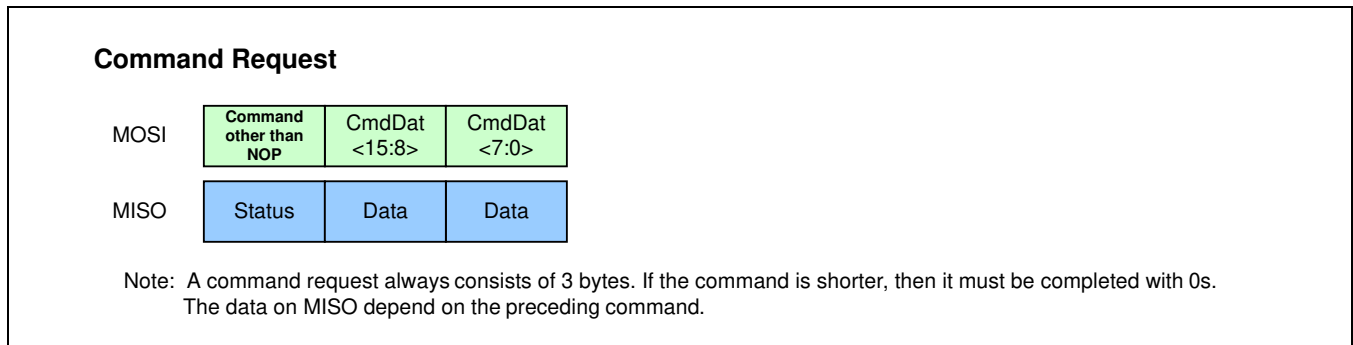

Figure 3.6 SPI Read Status

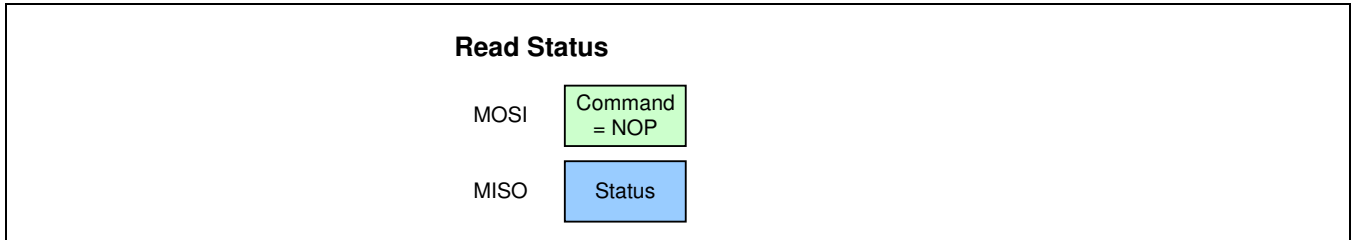
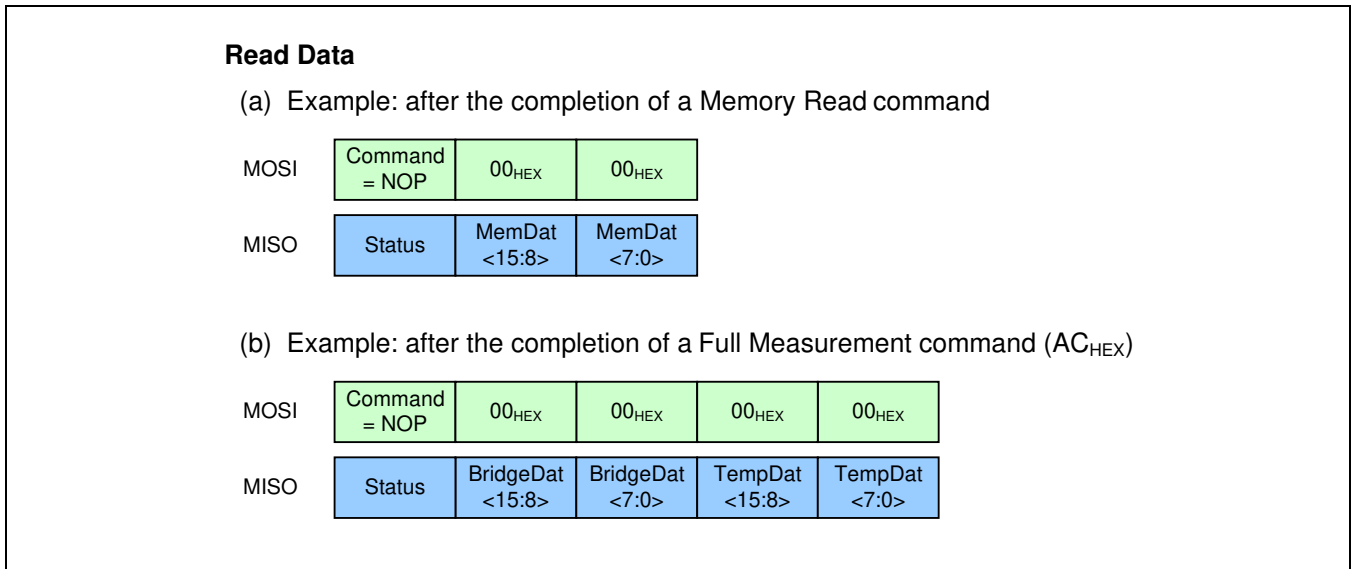

Figure 3.7 SPI Read Data



3.5.3. I²C™

I²C™ Mode is selected by SEL = 1. In I²C™ Mode, each command is started as shown in Figure 3.8. Only the number of bytes that is needed for the command must be sent. An exception is the HS-mode where 3 bytes must always be sent as in SPI Mode. After the execution of a command (busy = 0) the expected data can be read as illustrated in Figure 3.10 or if no data are returned by the command the next command can be sent. The status can be read at any time as described in Figure 3.9.

Figure 3.8 I²C™ Command Request

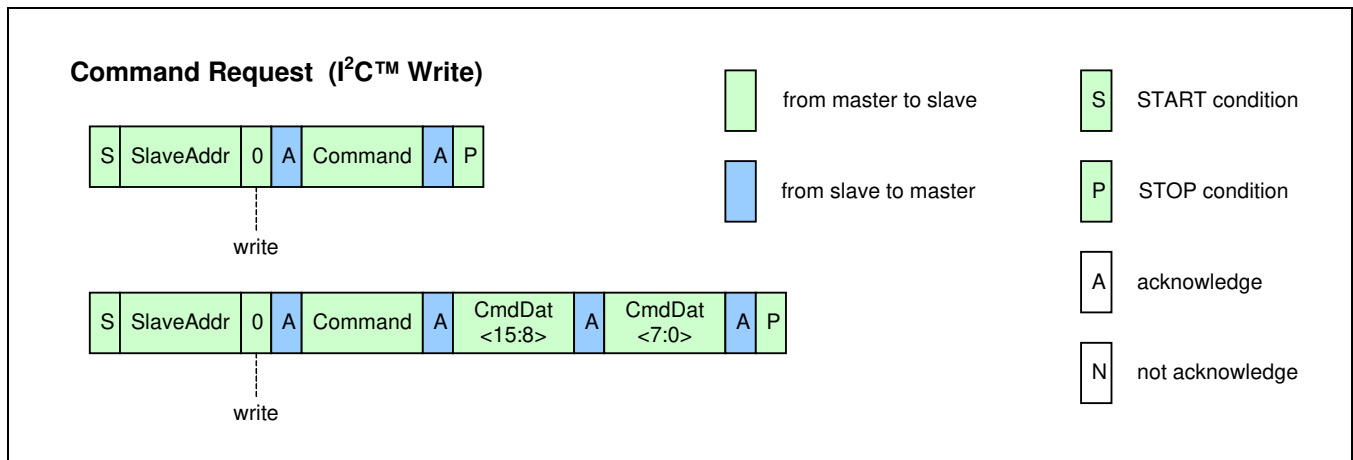

Figure 3.9 I²C™ Read Status

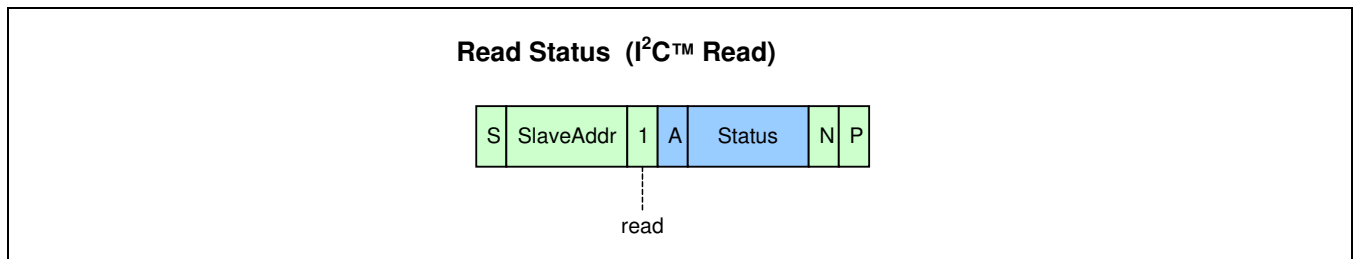
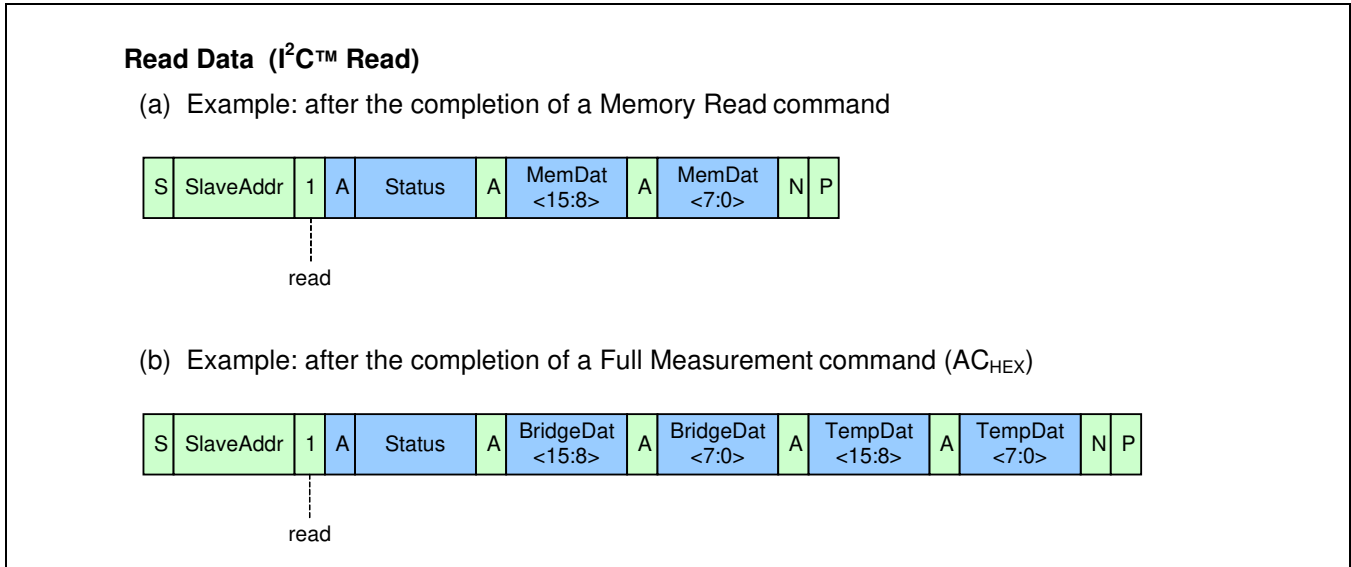

Figure 3.10 I²C™ Read Data



All mandatory I²C™ bus protocol features are implemented. Optional features such as clock stretching, 10-bit slave address, etc., are not supported by the ZSSC3026's interface.

In I²C™ High Speed Mode, a command consists of a fixed length of three bytes.

3.6. Memory

In the ZSSC3026, the memory is organized page-wise and can be programmed multiple (4) times (MTP). Each register can only be programmed once per page. The valid page is determined by the page counter, which can be incremented with the command 5E_{HEX}, which results in a “reset” of all registers and a re-programming is necessary. Increasing the customer page counter will disable all old register contents of the former page. It is possible to (re-)program a total of 4 pages. Resetting the page counter is not possible. The page counter starts with 0 and can be incremented to a maximum of 3. If the 4th memory page has been used, no further changes in the memory are possible – careful writing and page incrementing is strongly recommended.

There are two MTP page types:

- Customer Page: accessible by means of regular write operations (40_{HEX} to 57_{HEX}). It contains the customer ID, interface setup data, measurement setup information, calibration coefficients, etc.
- IDT Page: only accessible for write operations by IDT. The IDT page contains specific trim information and is programmed during manufacturing test by IDT.

3.6.1. Programming Memory

Programming memory requires a specific supply voltage level (>2.9V) at VDD pin (see section 1.3 for specifications). The MTP programming voltage itself is generated by means of an integrated charge pump; no additional, external voltage, other than VDD is needed. The program timing is shown in Figure 3.11, where t_{VPP} is the wait time until the memory has been programmed and the next command can be applied (typically 0.6μs). Supplying the ZSSC3026 with $VDD > 2.9V$ during memory programming is required. After the memory is programmed, it must be read again to verify the validity of the memory content.

Figure 3.11 Memory Program Operation

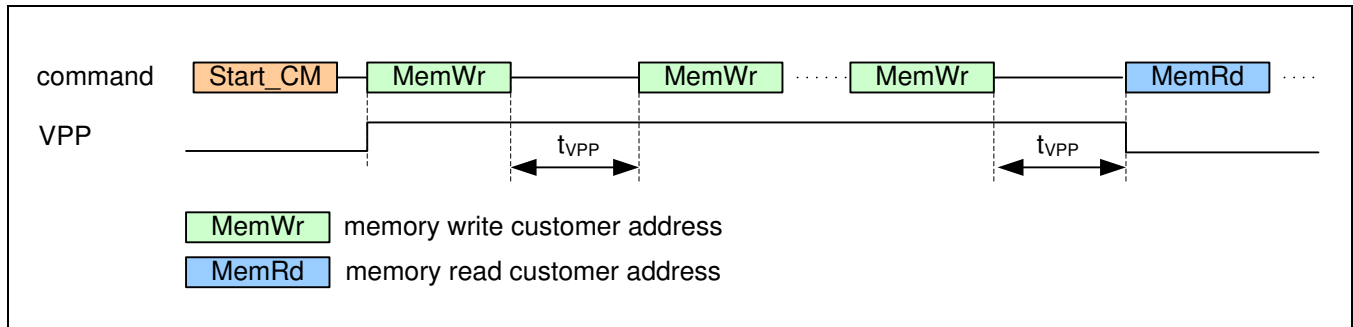

3.6.2. Memory Status Commands

The 16-bit memory status answer for the commands: 20_{HEX} to 37_{HEX} and 80_{HEX} to 8E_{HEX} contains the following information:

- One bit indicating if the data read was corrected.
- Two bits indicating the current page in use.

Table 3.7 Memory Status Word

Bit	Description
15 (MSB)	Data was corrected (0 = no, 1 = yes)
14	Current page
13	
12:0	Undefined – do not use

3.6.3. Memory Contents

Table 3.8 MTP Memory Content Assignments

MTP Address	Word / Bit Range	Default Setting	Description	Description
00 _{HEX}	15:0	0000 _{HEX}	Cust_ID0	Customer ID byte 0 (combines with memory word 01 _{HEX} to form customer ID)
01 _{HEX}	15:0	0000 _{HEX}	Cust_ID1	Customer ID byte 1 (combines with memory word 00 _{HEX} to form customer ID)
Interface Configuration				
02 _{HEX}	6:0	000 0000 _{BIN}	Slave_Addr	I ² C™ slave address; valid range: 00 _{HEX} to 7F _{HEX} (default: 00 _{HEX}); note: address codes 04 _{HEX} to 07 _{HEX} are reserved for entering I ² C™ High Speed Mode
	8:7	00 _{BIN}	-	Reserved
	9	0 _{BIN}	SS_polarity	Determines the polarity of the Slave Select pin (SS) for SPI operation: <ul style="list-style-type: none"> 0 ⇔ Slave Select is active low (SPI and ZSSC3026 are active if SS==0) 1 ⇔ Slave Select is active high (SPI and ZSSC3026 are active if SS==1)
	11:10	00 _{BIN}	CKP_CKE	Clock polarity and clock-edge select—determines polarity and phase of SPI interface clock with the following modes: <ul style="list-style-type: none"> 00 ⇔ SCLK is low in idle state; data latch with rising edge and data output with falling edge 01 ⇔ SCLK is low in idle state; data latch with falling edge and data output with rising edge 10 ⇔ SCLK is high in idle state; data latch with falling edge and data output with rising edge 11 ⇔ SCLK is high in idle state; data latch with rising edge and data output with falling edge
	15:12		-	Not assigned

MTP Address	Word / Bit Range	Default Setting	Description	Description
Signal Conditioning Parameters				
03 _{HEX}	0	0 _{BIN}	Offset_B[16]	Bridge offset, bit[16]; functions as the MSB and combines with Offset_B[15:0] in 05 _{HEX} to form the 17-bit coefficient's absolute value
	1	0 _{BIN}	Offset_B_sign	Sign for sensor bridge offset (Offset_B): 0 => a positive value 1 => a negative value
	2	0 _{BIN}	Gain_B[16]	Bridge gain, bit[16]; functions as the MSB and combines with Gain_B[15:0] in 06 _{HEX} to form the 17-bit coefficient's absolute value
	3	0 _{BIN}	Gain_B_sign	Sign of the sensor bridge gain (Gain_B): 0 => a positive value 1 => a negative value
	4	0 _{BIN}	Tcg[16]	1 st -order temperature coefficient of the bridge gain, bit[16]; functions as the MSB and combines with Tcg[15:0] in 07 _{HEX} to form 17-bit coefficient's absolute value
	5	0 _{BIN}	Tcg_sign	Sign of 1 st -order temperature coefficient (Tcg): 0 => a positive value 1 => a negative value
	6	0 _{BIN}	Tco[16]	1 st -order temperature coefficient of the bridge offset, bit[16]; functions as the MSB and combines with Tco[15:0] in 08 _{HEX} to form 17-bit coefficient's absolute value
	7	0 _{BIN}	Tco_sign	Sign of 1 st -order temperature coefficient (Tco): 0 => a positive value 1 => a negative value
	8	0 _{BIN}	SOT_tco[16]	2 nd -order temperature coefficient of the bridge offset, bit[16]; functions as the MSB and combines with SOT_tco[15:0] in 09 _{HEX} to form 17-bit coefficient's absolute value
	9	0 _{BIN}	SOT_tco_sign	Sign setting for 2 nd -order temperature coefficient (SOT_tco): 0 => a positive value 1 => a negative value
	10	0 _{BIN}	SOT_tcg[16]	2 nd -order temperature coefficient of the bridge gain, bit[16]; functions as the MSB and combines with SOT_tcg[15:0] in 0A _{HEX} to form 17-bit coefficient's absolute value
	11	0 _{BIN}	SOT_tcg_sign	Sign setting for 2 nd -order temperature coefficient (SOT_tcg): 0 => a positive value 1 => a negative value

MTP Address	Word / Bit Range	Default Setting	Description	Description
	12	0 _{BIN}	SOT_bridge[16]	2 nd -order coefficient of the bridge signal, bit[16]; functions as the MSB and combines with SOT_bridge[15:0] in 0B _{HEX} to form the 17-bit coefficient's absolute value
	13	0 _{BIN}	SOT_bridge_sign	Sign setting for 2 nd -order bridge coefficient (SOT_bridge): 0 => a positive value 1 => a negative value
	14	0 _{BIN}	SOT_curve	Type of second order curve correction for the bridge sensor signal: 0 ⇔ parabolic curve 1 ⇔ s-shaped curve
	15	0 _{BIN}	TSETL_sign	Sign setting for T_SETL: 0 => a positive value 1 => a negative value
04 _{HEX}	0	0 _{BIN}	Gain_T[16]	Temperature gain of temperature sensor, bit[16]; functions as the MSB and combines with Gain_T[15:0] in 0D _{HEX} to form 17-bit coefficient's absolute value
	1	0 _{BIN}	Gain_T_sign	Sign setting for temperature gain (Gain_T): 0 => a positive value 1 => a negative value
	2	0 _{BIN}	SOT_T[16]	2 nd -order temperature coefficient of temperature sensor, bit[16]; functions as the MSB and combines with SOT_T[15:0] in 0E _{HEX} to form 17-bit coefficient's absolute value
	3	0 _{BIN}	SOT_T_sign	Sign setting for 2 nd -order temperature coefficient (SOT_T): 0 => a positive value 1 => a negative value
	4	0 _{BIN}	Offset_T[16]	Temperature offset of temperature sensor, bit[16]; functions as the MSB and combines with Offset_T[15:0] in 0C _{HEX} to form 17-bit coefficient's absolute value
	5	0 _{BIN}	Offset_T_sign	Sign setting for the temperature offset (Offset_T): 0 => a positive value or 1 => a negative value
	15:6	0 0000 0000 _{BIN}	-	Not assigned

MTP Address	Word / Bit Range	Default Setting	Description	Description
05 _{HEX}	15:0	0000 _{HEX} (7000 _{HEX})	Offset_B[15:0]	<p>Bits [15:0] of the bridge offset correction coefficient, which is an 18-bit wide absolute value; the respective MSBs Offset_B[16] and sign, Offset_B_sign, are under bits[1:0] in 03_{HEX}:</p> <p>[-1/16 to 15/16] = 7000_{HEX} (default for volume) [-2/16 to 14/16] = 6000_{HEX} [-3/16 to 13/16] = 5000_{HEX} [-4/16 to 12/16] = 4000_{HEX} [-5/16 to 11/16] = 3000_{HEX} [-6/16 to 10/16] = 2000_{HEX} [-7/16 to 9/16] = 1000_{HEX} [-8/16 to 8/16] = 0000_{HEX} (default for prototypes)</p>
06 _{HEX}	15:0	0000 _{HEX} (8000 _{HEX})	Gain_B[15:0]	<p>Bits[15:0] of 17-bit wide absolute value of the bridge gain coefficient (default for prototypes: 0000_{HEX}; default for volume production: 8000_{HEX}); the respective MSBs, Gain_B[16] and sign, Gain_B_sign, are under bits[3:2] in 03_{HEX}</p>
07 _{HEX}	15:0	0000 _{HEX}	Tcg[15:0]	<p>Coefficient for temperature correction of the bridge gain term; the respective MSBs, Tcg[16] and sign, Tcg_sign, are under bits[5:4] in 03_{HEX}</p>
08 _{HEX}	15:0	0000 _{HEX}	Tco[15:0]	<p>Coefficient for temperature correction of the bridge offset term; the respective MSBs, Tco[16] and sign, Tco_sign, are under bits[7:6] in 03_{HEX}</p>
09 _{HEX}	15:0	0000 _{HEX}	SOT_tco[15:0]	<p>2nd-order term applied to Tco; the respective MSBs, SOT_tco[16] and sign, SOT_tco_sign, are under bits[9:8] in 03_{HEX}</p>
0A _{HEX}	15:0	0000 _{HEX}	SOT_tcg[15:0]	<p>2nd-order term applied to Tcg; the respective MSBs, SOT_tcg[16] and sign, SOT_tcg_sign, are under bits[11:10] in 03_{HEX}</p>
0B _{HEX}	15:0	0000 _{HEX}	SOT_bridge[15:0]	<p>2nd-order term applied to the sensor bridge readout; the respective MSBs, SOT_bridge[16] and sign, SOT_bridge_sign are under bits[13:12] in 03_{HEX}</p>
0C _{HEX}	15:0	0000 _{HEX} (7000 _{HEX})	Offset_T[15:0]	<p>Bits [15:0] of the temperature offset correction coefficient; the respective MSBs, Offset_T[16] and sign, Offset_T_sign, are under bits[5:4] in 04_{HEX}:</p> <p>[-1/16 to 15/16] = 7000_{HEX} (default for volume) [-2/16 to 14/16] = 6000_{HEX} [-3/16 to 13/16] = 5000_{HEX} [-4/16 to 12/16] = 4000_{HEX} [-5/16 to 11/16] = 3000_{HEX} [-6/16 to 10/16] = 2000_{HEX} [-7/16 to 9/16] = 1000_{HEX} [-8/16 to 8/16] = 0000_{HEX} (default for prototypes)</p>

MTP Address	Word / Bit Range	Default Setting	Description	Description
0D _{HEX}	15:0	0000 _{HEX} (8000 _{HEX})	Gain_T[15:0]	Bits [15:0] of the absolute value of the temperature gain coefficient (default for prototypes: 0000 _{HEX} ; default for volume production: 8000 _{HEX}); the respective MSBs, Gain_T[16] and sign, Gain_T_sign, are under bits[1:0] in 04 _{HEX}
0E _{HEX}	15:0	0000 _{HEX}	SOT_T[15:0]	2 nd -order term applied to the temperature reading; the respective MSBs, SOT_T[16] and sign, SOT_T_sign, are under bits[3:2] in 04 _{HEX}
0F _{HEX}	15:0	0000 _{HEX}	T_SETL	Stores raw temperature reading at the temperature at which low calibration points were taken
Measurement Configuration Register (<i>BM_config</i>)				
10 _{HEX}	1:0	00 _{BIN}	Gain_stage1	Gain setting for the 1 st PREAMP stage with Gain_stage1: <ul style="list-style-type: none"> • 00 ⇔ 12 • 01 ⇔ 20 • 10 ⇔ 30 • 11 ⇔ 40
	4:2	000 _{BIN}	Gain_stage2	Gain setting for the 2 nd PREAMP stage with Gain_stage2: <ul style="list-style-type: none"> • 000 ⇔ 1.1 • 001 ⇔ 1.2 • 010 ⇔ 1.3 • 011 ⇔ 1.4 • 100 ⇔ 1.5 • 101 ⇔ 1.6 • 110 ⇔ 1.7 • 111 ⇔ 1.8
	5	0 _{BIN}	Gain_polarity	Set up the polarity of the sensor bridge's gain (inverting of the chopper) with <ul style="list-style-type: none"> • 0 ⇔ positive (no polarity change) • 1 ⇔ negative (180° polarity change)
	7:6	00 _{BIN} (11 _{BIN})	Msb	Absolute number of bits for the MSB conversion in the ADC with Msb: <ul style="list-style-type: none"> • 00 ⇔ 10-bit • 01 ⇔ 12-bit • 10 ⇔ 14-bit • 11 ⇔ 16-bit

MTP Address	Word / Bit Range	Default Setting	Description	Description
	9:8	00 _{BIN}	Lsb	Absolute number of bits for the LSB conversion in the ADC with Lsb: <ul style="list-style-type: none"> • 00 ⇔ 0-bit (single stage CB_ADC) • 01 ⇔ 2-bit • 10 ⇔ 4-bit • 11 ⇔ 6-bit
	12:10	000 _{BIN}	A2D_Offset	ADC offset and resulting A2D input range [Vref] with A2D_Offset: <ul style="list-style-type: none"> • 000 ⇔ 1/16 results in range [-1/16, 15/16] • 001 ⇔ 2/16 results in range [-2/16, 14/16] • 010 ⇔ 3/16 results in range [-3/16, 13/16] • 011 ⇔ 4/16 results in range [-4/16, 12/16] • 100 ⇔ 5/16 results in range [-5/16, 11/16] • 101 ⇔ 6/16 results in range [-6/16, 10/16] • 110 ⇔ 7/16 results in range [-7/16, 9/16] • 111 ⇔ 8/16 results in range [-8/16, 8/16]
	14:13	00 _{BIN}	Temp_ADC	Selection between fixed ADC segmentations for temperature measurements: <ul style="list-style-type: none"> • 00 ⇔ setup according to IDT-reserved memory (recommended setup for best performance and speed trade-off) • 01 ⇔ MSB=16, LSB=0 (16-bit) • 10 ⇔ MSB=10, LSB=6 (16-bit) • 11 ⇔ MSB=12, LSB=4 (16-bit)
	15	0 _{BIN}	-	Reserved
11 _{HEX}				Not assigned
12 _{HEX}				Not assigned
13 _{HEX}				Not assigned
14 _{HEX}				Not assigned
15 _{HEX}				Not assigned
16 _{HEX}				Not assigned
17 _{HEX}	15:0	-	ChecksumC	Generated checksum for user page through a linear feedback shift register (LFSR); signature is checked with power-up to ensure memory content integrity

The memory integrity checksum (i.e., CRC) is generated through a linear feedback shift register with the polynomial:

$$g(x) = x^{16} + x^{15} + x^2 + 1 \quad \text{with the initialization value } \text{FFFF}_{\text{HEX}}$$

3.7. Calibration Sequence

Calibration essentially involves collecting raw signal and temperature data from the sensor-ZSSC3026 system for different known bridge values and temperatures. This raw data can then be processed by the calibration master (assumed to be a PC), and the calculated calibration coefficients can then be written to MTP memory. Below is a brief overview of the steps involved in calibrating the ZSSC3026.

There are three main steps to calibration:

1. *Assigning a unique identification to the ZSSC3026.* This identification is written to shadow RAM and later programmed in MTP memory. This unique identification can be stored in the two 16-bit registers dedicated to customer ID. It can be used as an index in a database stored on the calibration PC. This database will contain all the raw values of bridge readings and temperature readings for that part, as well as the known bridge measurand conditions and temperature to which the bridge was exposed.
2. *Data collection.* Data collection involves getting uncorrected or raw data from the bridge at different known measurand values and temperatures. Then this data is stored on the calibration PC using the unique identification of the device as the index to the database.
3. *Coefficient calculation and storage in MTP memory.* After enough data points have been collected to calculate all the desired coefficients, the coefficients can be calculated by the calibrating PC and written to the shadow RAM. After that, MTP memory is programmed with the contents of the shadow RAM.
4. *Result.* The sensor signal and the characteristic temperature effect on output will be linearized according to the setup-dependent maximum output range.

It is essential to perform the calibration with a fixed programming setup during the data collection phase. In order to prevent any accidental misprocessing, it is further recommended to keep the MTP memory setup stable during the whole calibration process as well as in the subsequent operation. A ZSSC3026 calibration only fits the single setup used during its calibration. Changes in functional parameters after a successful calibration can decrease the precision and accuracy performance of the ZSSC3026 as well as of the whole application.

3.7.1. Calibration Step 1 – Assigning Unique Identification

Assign a unique identification number to the ZSSC3026 by using the memory write command (40_{HEX} + data and 41_{HEX} + data; see Table 3.1 and Table 3.8) to write the identification number to Cust_ID0 at memory address 00_{HEX} and Cust_ID1 at address 01_{HEX} as described in section 3.6.1. These two 16-bit registers allow for more than 4 billion unique devices.

3.7.2. Calibration Step 2 – Data Collection

The number of unique points (measurand and/or temperature) at which calibration must be performed generally depends on the requirements of the application and the behavior of the resistive bridge in use. The minimum number of points required is equal to the number of bridge coefficients to be corrected with a minimum of three different temperatures at three different bridge values. For a full calibration resulting in values for all 7 possible bridge coefficients and 3 possible temperature coefficients, a minimum of 7 pairs of bridge with temperature measurements must be collected.

Within this minimum 3x3 measurements field, data must be collected for the specific value pairs at known conditions and then processed to calculate the coefficients. In order to obtain the potentially best and most robust coefficients, it is recommended that measurement pairs (temperature vs. measurand) be collected at the outer corners of the intended operation range or at least at points that are located far from each other. It is also essential to provide highly precise reference values as nominal, expected values. The measurement precision of the external calibration-measurement equipment should be ten times more accurate than the expected ZSSC3026 output precision after calibration in order to avoid precision losses caused by the nominal reference values (e.g., measurand signal and temperature deviations).

Note: An appropriate selection of measurement pairs can significantly improve the overall system performance.

The determination of the measurand-related coefficients will use all of the measurement pairs. For the temperature-related correction coefficients, 3 (at three different temperatures) of the measurement pairs will be used.

Note: There is an inherent redundancy in the 7 bridge-related and 3 temperature-related coefficients. Since the temperature is a necessary output (which also needs correction), the temperature-related information is mathematically separated, which supports faster and more efficient DSP calculations during the normal usage of the sensor-ZSSC3026 system.

The recommended approach for data collection is to make use of the raw-measurement commands:

- For bridge sensor values:
 - $A2_{\text{HEX}} + 0000_{\text{HEX}}$: Single bridge measurement for which the configuration register will be loaded from the *BM_config* register (10_{HEX} in MTP); preprogramming the measurement setup in the MTP is required.
 - $A3_{\text{HEX}} + \text{ssss}_{\text{HEX}}$: Single bridge measurement for which the *BM_config* configuration register (Gain, ADC, Offset, etc.) will be loaded as ssss_{HEX} and must be provided externally via the interface.
- For temperature values:
 - $A6_{\text{HEX}} + 0000_{\text{HEX}}$: Single temperature measurement for which the configuration register will be loaded from an internal temperature configuration register (preprogrammed by IDT in MTP); preprogramming of the respective configuration is done by IDT prior to ZSSC3026 delivery. This is the recommended approach for temperature data collection.
 - $A7_{\text{HEX}} + \text{ssss}_{\text{HEX}}$: Single temperature measurement for which the configuration register (Gain, ADC, Offset, etc.) will be loaded as ssss_{HEX} and must be provided externally via the interface. The data composition of the temperature configuration register is similar to the *BM_config* (address 10_{HEX}) register for the bridge sensor.

3.7.3. Calibration Step 3 – Coefficient Calculations

The math to perform the coefficient calculation is complicated and will not be discussed in detail. There is a brief overview in the next section. IDT will provide software (DLLs) to perform the coefficient calculation (external to the sensor-ZSSC3026 system) based on auto-zero corrected values. After the coefficients are calculated, the final step is to write them to the MTP memory of the ZSSC3026.

3.8. The Calibration Math

3.8.1. Bridge Signal Compensation

The saturation check in the ZSSC3026 is enhanced compared with older SSCs from IDT. Even saturation effects of the internal calculation steps are detected, allowing the final correction output to still be determined. It is possible to get potentially useful signal conditioning results that have seen an intermediate saturation during the calculations – these cases are detectable by observing the status bit[0] for each measurement result. Details about the saturation limits and the valid ranges for values are provided in the following equations.

SOT_curve selects whether second-order equations compensate for sensor nonlinearity with a parabolic or S-shaped curve. The parabolic compensation is recommended.

The correction formula for the differential signal reading is represented as a two-step process depending on the *SOT_curve* setting.

For the following measurand equations, the terms are as follows:

- B* = Corrected bridge reading output via I²C™ or SPI; range [0_{HEX} to FFFF_{HEX}]
- BR_Raw* = Raw bridge reading from ADC after AZ correction; range [-1FFFF_{HEX} to 1FFFF_{HEX}]
- Gain_B* = Bridge gain term; range [-1FFFF_{HEX} to 1FFFF_{HEX}]
- Offset_B* = Bridge offset term; range [-1FFFF_{HEX} to 1FFFF_{HEX}]
- Tcg* = Temperature coefficient gain term; range [-1FFFF_{HEX} to 1FFFF_{HEX}]
- Tco* = Temperature coefficient offset term; range [-1FFFF_{HEX} to 1FFFF_{HEX}]
- T_Raw* = Raw temperature reading after AZ correction; range [-1FFFF_{HEX} to 1FFFF_{HEX}]
- T_SETL* = T_Raw reading at which low calibration was performed (e.g., 25°C); range [-FFFF_{HEX} to FFFF_{HEX}]
- SOT_tcg* = Second-order term for Tcg non-linearity; range [-1FFFF_{HEX} to 1FFFF_{HEX}]
- SOT_tco* = Second-order term for Tco non-linearity; range [-1FFFF_{HEX} to 1FFFF_{HEX}]
- SOT_bridge* = Second-order term for bridge non-linearity; range [-1FFFF_{HEX} to 1FFFF_{HEX}]
- |...| = Absolute value
- [...]_{ll}^{ul} = Bound/saturation number range from *ll* to *ul*, over/under-flow is reported as saturation in status byte

Equations for the parabolic SOT_curve setting ($SOT_curve = 0$):

Simplified:

$$\Delta T = T_Raw - T_{SETL} \quad (5)$$

$$K_1 = 2^{15} + \frac{\Delta T}{2^{15}} \cdot \left(\frac{SOT_tcg}{2^{15}} \cdot \Delta T + Tcg \right) \quad (6)$$

$$K_2 = Offset_B + BR_Raw + \frac{\Delta T}{2^{15}} \cdot \left(\frac{SOT_tco}{2^{15}} \cdot \Delta T + Tco \right) \quad (7)$$

$$Z_{BP} = \frac{Gain_B}{2^{15}} \cdot \frac{K_1}{2^{15}} \cdot K_2 + 2^{15} \quad (\text{delimited to positive number range}) \quad (8)$$

$$B = \frac{Z_{BP}}{2^{15}} \cdot \left(\frac{SOT_bridge}{2^{15}} \cdot Z_{BP} + 2^{15} \right) \quad (\text{delimited to positive number range}) \quad (9)$$

Complete:

$$\Delta T = \left[T_Raw - T_{SETL} \right]_{-2^{17}}^{2^{17}-1} \quad (10)$$

$$K_1 = \left[2^{15} + \left[\frac{\Delta T}{2^{15}} \cdot \left[\left[\frac{SOT_tcg}{2^{15}} \cdot \Delta T \right]_{-2^{17}}^{2^{17}-1} + Tcg \right]_{-2^{17}}^{2^{17}-1} \right]_{-2^{17}}^{2^{17}-1} \right] \quad (11)$$

$$K_2 = \left[Offset_B + \left[BR_Raw + \left[\frac{\Delta T}{2^{15}} \cdot \left[\left[\frac{SOT_tco}{2^{15}} \cdot \Delta T \right]_{-2^{17}}^{2^{17}-1} + Tco \right]_{-2^{17}}^{2^{17}-1} \right]_{-2^{17}}^{2^{17}-1} \right]_{-2^{17}}^{2^{17}-1} \right] \quad (12)$$

$$Z_{BP} = \left[\left[\frac{Gain_B}{2^{15}} \cdot \left[\left[\frac{K_1}{2^{15}} \cdot K_2 \right]_{-2^{17}}^{2^{17}-1} \right]_{-2^{17}}^{2^{17}-1} + 2^{15} \right]_{-2^{17}}^{2^{17}-1} \right]_0 \quad (13)$$

$$B = \left[\frac{Z_{BP}}{2^{15}} \cdot \left[\left[\frac{SOT_bridge}{2^{15}} \cdot Z_{BP} \right]_{-2^{17}}^{2^{17}-1} + 2^{15} \right]_{-2^{17}}^{2^{17}-1} \right]_0 \quad (14)$$

Equations for the S-shaped *SOT_curve* setting (*SOT_curve* = 1):

Simplified:

$$Z_{BS} = \frac{Gain_B}{2^{15}} \cdot \frac{K_1}{2^{15}} \cdot K_2 \quad (15)$$

$$B = \frac{Z_{BS}}{2^{15}} \cdot \left(\frac{SOT_bridge}{2^{15}} \cdot |Z_{BS}| + 2^{15} \right) + 2^{15} \quad (\text{delimited to positive number range}) \quad (16)$$

Complete:

$$Z_{BS} = \left[\frac{Gain_B}{2^{15}} \cdot \left[\frac{K_1}{2^{15}} \cdot K_2 \right]_{-2^{17}}^{2^{17}-1} \right]_{-2^{17}}^{2^{17}-1} \quad (17)$$

$$B = \left[\frac{Z_{BS}}{2^{15}} \cdot \left[\left[\frac{SOT_bridge}{2^{15}} \cdot |Z_{BS}| \right]_{-2^{17}}^{2^{17}-1} + 2^{15} \right]_{-2^{17}}^{2^{17}-1} + 2^{15} \right]_0^{2^{16}} \quad (18)$$

3.8.2. Temperature Signal Compensation

Temperature is measured internally. Temperature correction contains both linear gain and offset terms as well as a second-order term to correct for any nonlinearities. For temperature, second-order compensation for non-linearity is always parabolic. The correction formula is best represented as a two-step process as follows:

Simplified:

$$Z_T = \frac{Gain_T}{2^{15}} \cdot (T_Raw + Offset_T) + 2^{15} \quad (\text{delimited to positive number range}) \quad (19)$$

$$T = \frac{Z_T}{2^{15}} \cdot \left(\frac{SOT_T}{2^{15}} \cdot Z_T + 2^{15} \right) \quad (\text{delimited to positive number range}) \quad (20)$$

Complete:

$$Z_T = \left[\frac{Gain_T}{2^{15}} \cdot [T_Raw + Offset_T]_{-2^{17}}^{2^{17}-1} \right]_{-2^{17}}^{2^{17}-1} + 2^{15} \quad (21)$$

$$T = \left[\frac{Z_T}{2^{15}} \cdot \left[\left[\frac{SOT_T}{2^{15}} \cdot Z_T \right]_{-2^{17}}^{2^{17}-1} + 2^{15} \right]_{-2^{17}}^{2^{17}-1} \right]_0^{2^{16}-1} \quad (22)$$

Where

- Gain_T* = Gain coefficient for temperature; range [-1FFFF_{HEX} to 1FFFF_{HEX}];
- T_Raw* = Raw temperature reading after AZ correction; range [-1FFFF_{HEX} to 1FFFF_{HEX}];
- Offset_T* = Offset coefficient for temperature; range [-1FFFF_{HEX} to 1FFFF_{HEX}];
- SOT_T* = Second-order term for temperature source non-linearity; range [-1FFFF_{HEX} to 1FFFF_{HEX}]

4 Die and Package Characteristics

The ZSSC3026 is available in three delivery forms: die for wafer bonding; bumped die for Flip Chip; and packaged parts in a PQFN24 4x4mm package.

4.1. Die Pad Assignments

Figure 4.1 gives the pad assignments for the die.

Note: Pins labeled ZMDI-test are not available for customer use.

Figure 4.1 ZSSC3026 Pad Placement

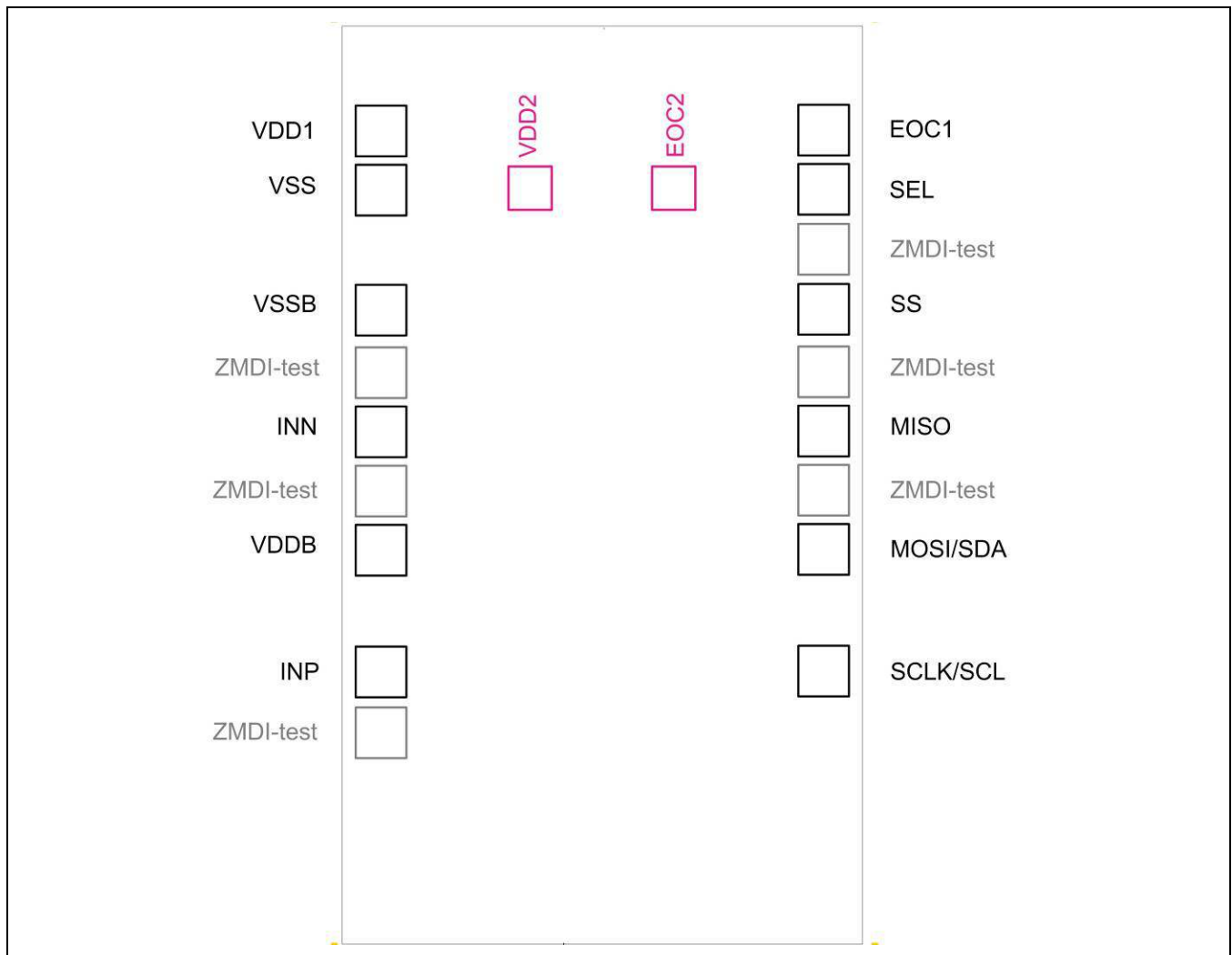

Table 4.1 Die Pad Assignments

Name	Direction	Type	Description
VDD1	IN	Supply	ZSSC3026 positive supply voltage for the IC, regular bond pad
VDD2			ZSSC3026 positive supply voltage for the IC, special pad (electrically connected to VDD1, also bondable)
VSS	IN	Supply	Ground reference voltage signal
VSSB	OUT	Analog	Negative bridge supply (bridge sensor ground)
Vddb	OUT	Analog	Positive bridge supply
INP	IN	Analog	Positive bridge signal
INN	IN	Analog	Negative bridge signal
EOC1	OUT	Digital	End of conversion, regular bond pad
EOC2			End of conversion, special pad (electrically connected to EOC1, also bondable)
SEL	IN	Digital	I ² C™ or SPI interface select
SCLK/SCL	IN	Digital	Clock input for I ² C™/SPI
MOSI/SDA	IN/Out	Digital	Data input for SPI; data in/out for I ² C™
MISO	OUT	Digital	Data output for SPI
SS	IN	Digital	Slave select for SPI
ZMDI-test	-	-	Do not connect to these pads

4.2. Package (PQFN24) Properties

Figure 4.2 General PQFN24 Package Dimensions

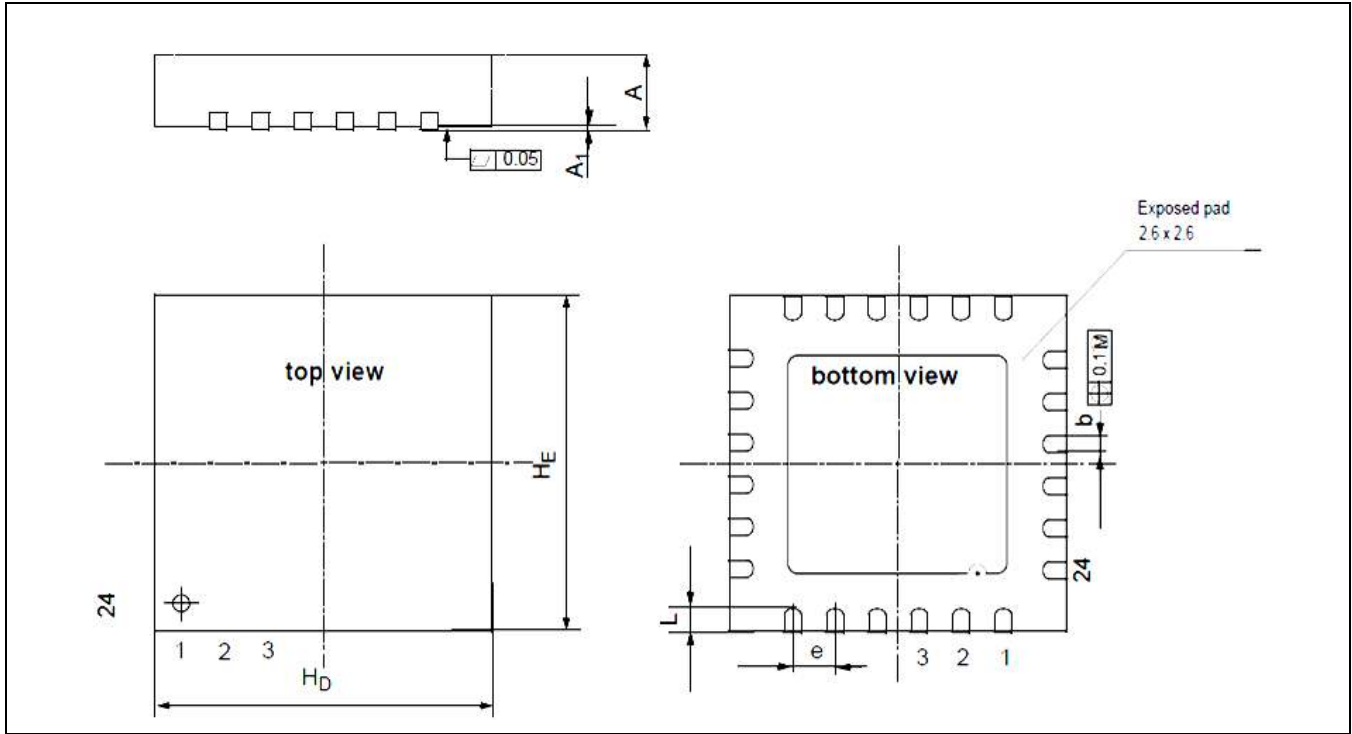

Table 4.2 Physical Package Dimensions

Parameter / Dimension	Min (mm)	Max (mm)
A	0.80	0.90
A ₁	0.00	0.05
e	0.5 nom	
H _D	3.90	4.10
H _E	3.90	4.10
L	0.35	0.45

Table 4.3 Pin Assignments PQFN24

Note: For the pin names, “n.c.” stands for “not connected / no connection required / not bonded.”

Pin Number	Name	Direction	Type	Description
1	VSS	IN	Supply	Ground reference voltage signal
2	VSSB	OUT	Supply	Sensor bridge's ground
3	ZMDI-test	-	-	Do not connect
4	INN	IN	Analog	Negative bridge signal
5	ZMDI-test	-	-	Do not connect
6	Vddb	OUT	Supply	Supply for sensor bridge (driven from the ZSSC3026) Important: Do not short with VDD!
7	INP	IN	Analog	Positive bridge signal
8	ZMDI-test	-	-	Do not connect
9	n.c.	-	-	-
10	n.c.	-	-	-
11	SCLK/SCL	IN	Digital	Clock input for I ² C™ / SPI
12	MOSI/SDA	IN / OUT	Digital	Data input for SPI, data in/out-line for I ² C™
13	ZMDI-test	-	-	Do not connect
14	MISO	IN	Digital	Data output for SPI
15	ZMDI-test	-	-	Do not connect
16	SS	IN	Digital	Slave select for SPI
17	ZMDI-test	-	-	Do not connect
18	SEL	IN	Digital	I ² C™ or SPI interface select (internal pull up, 0 = SPI, 1 = I ² C™)
19	EOC	OUT	Digital	End of conversion; can be used as “measurement completed” trigger
20	n.c.	-	-	-
21	n.c.	-	-	-
22	n.c.	-	-	-
23	n.c.	-	-	-
24	VDD	IN	Supply	Supply voltage for ZSSC3026

5 Quality and Reliability

The ZSSC3026 is available in standard and extended qualification versions. For the standard version, ZSSC3026CC_{xxx}, all data sheet specified parameters are guaranteed if not stated otherwise.

For the extended qualification version, ZSSC3026C_{Ixxx}, the MTP's data retention capability over ten years (see Table 1.4) is guaranteed as well as specific testing in order to sort for IC-specific (HTOL-qualified) early failures.

6 Ordering Information

Please contact IDT Sales for additional options.

Sales Code	Description	Package
ZSSC3026CC1B	ZSSC3026 Die — temperature range: –40°C to +85 °C, tested	Unsawn wafer (304µm)
ZSSC3026C11B	ZSSC3026 Die — temperature range: –40°C to +85 °C; extended qualification: tested, 10 years MTP-data retention, HTOL tested	Unsawn wafer (304µm)
ZSSC3026KIT	Evaluation Kit for ZSSC30x6 Product Family; two circuit boards, cable, and 1 sample (Evaluation Software is downloadable from www.IDT.com/ZSSC3026)	Kit

7 Related Documents

Document
ZSSC3026 <i>Feature Sheet</i>
ZSSC3026 <i>Application Note—Application Circuits</i>
ZSSC30x6 <i>Evaluation Kit Documentation</i>
ZSSC30x6 <i>Application Note—Calibration</i>

Visit the ZSSC3026 product page www.IDT.com/ZSSC3026 or contact your nearest sales office for the latest version of these documents.

8 Glossary

Term	Description
ACK	Acknowledge (interface's protocol indicator for successful data/command transfer)
ADC	Analog-to-Digital Converter or Conversion
AZ	Auto-Zero (unspecific)
AZB	Auto-Zero Measurement for Sensor Bridge Path
AZT	Auto-Zero Measurement for Temperature Path
CLK	Clock
DAC	Digital-to-Analog Conversion or Converter
DF	Data Fetch (this is a command type)
DSP	Digital Signal Processor (digital configuration, calibration, calculation, communication unit)
EOC	End of Conversion
FSO	Full Scale Output (value in percent relative to the ADC maximum output code; resolution dependent)
HTOL	High Temperature Operating Life
LSB	Least Significant Bit (also "fine" portion of the converted signal)
LFSR	Linear Feedback Shift Register
MISO	Master Input, Slave Output (SPI)
MOSI	Master Output, Slave Input (SPI)
MR	Measurement Request (this is a command type)
MSB	Most Significant Bit (also "coarse" portion of the converted signal)
MTP	Multiple-Time Programmable
NACK	Not Acknowledge (interface's protocol indicator for unsuccessful data/command transfer)
OTP	One Time Programmable
POR	Power-On Reset
PSRR	Power Supply Disturbance Rejection
SCL	Serial Clock Line (I ² C™)
SCLK	Serial Clock (SPI)
SDA	Serial Data Line (I ² C™)
SM	Signal Measurement
SPI	Serial Peripheral Interface
SOT	Second-Order Term
TC	Temperature Coefficient (of a resistor or the equivalent bridge resistance)
TM	Temperature Measurement

9 Document Revision History

Revision	Date	Description
1.00	January 06, 2012	First release.
1.01	March 28, 2012	Change of ESD limit to 4kV, additional bump information; reset conditions added.
1.02	May 15, 2012	Included adjustments for temperature capabilities up to 110°C.
1.03	June 14, 2012	Minor corrections; explanation for sensor setup selection added.
1.04	March 1, 2016	<p>Revision of the maximum temperature range specification from 110°C to 85°C in section 1.2.</p> <p>Related revision of part codes: part code ZSSC3026CI4 (temperature range: -40°C to 110°C) is no longer available.</p> <p>Revision of Sleep State current to 50nA typical on page 2.</p> <p>Revision of operating mode current consumption to 900µA.</p> <p>Update for section 2.3.3 for description of internal temperature sensor.</p> <p>Update for pin names in block diagrams.</p> <p>Updates for Figure 3.1 and Figure 3.2.</p> <p>Updates for section 3.6.1 to define time for t_{TYP}.</p> <p>Software for kit is now downloaded from the product web page.</p> <p>Addition of Table 2.5.</p> <p>Update for imagery for cover and header.</p> <p>Update for contact information.</p> <p>Update for die information.</p> <p>Minor edits for clarity.</p>
	March 28, 2016	Changed to IDT branding.

IMPORTANT NOTICE AND DISCLAIMER

RENESAS ELECTRONICS CORPORATION AND ITS SUBSIDIARIES (“RENESAS”) PROVIDES TECHNICAL SPECIFICATIONS AND RELIABILITY DATA (INCLUDING DATASHEETS), DESIGN RESOURCES (INCLUDING REFERENCE DESIGNS), APPLICATION OR OTHER DESIGN ADVICE, WEB TOOLS, SAFETY INFORMATION, AND OTHER RESOURCES “AS IS” AND WITH ALL FAULTS, AND DISCLAIMS ALL WARRANTIES, EXPRESS OR IMPLIED, INCLUDING, WITHOUT LIMITATION, ANY IMPLIED WARRANTIES OF MERCHANTABILITY, FITNESS FOR A PARTICULAR PURPOSE, OR NON-INFRINGEMENT OF THIRD PARTY INTELLECTUAL PROPERTY RIGHTS.

These resources are intended for developers skilled in the art designing with Renesas products. You are solely responsible for (1) selecting the appropriate products for your application, (2) designing, validating, and testing your application, and (3) ensuring your application meets applicable standards, and any other safety, security, or other requirements. These resources are subject to change without notice. Renesas grants you permission to use these resources only for development of an application that uses Renesas products. Other reproduction or use of these resources is strictly prohibited. No license is granted to any other Renesas intellectual property or to any third party intellectual property. Renesas disclaims responsibility for, and you will fully indemnify Renesas and its representatives against, any claims, damages, costs, losses, or liabilities arising out of your use of these resources. Renesas' products are provided only subject to Renesas' Terms and Conditions of Sale or other applicable terms agreed to in writing. No use of any Renesas resources expands or otherwise alters any applicable warranties or warranty disclaimers for these products.

(Disclaimer Rev.1.0 Mar 2020)

Corporate Headquarters

TOYOSU FORESIA, 3-2-24 Toyosu,
Koto-ku, Tokyo 135-0061, Japan
www.renesas.com

Contact Information

For further information on a product, technology, the most up-to-date version of a document, or your nearest sales office, please visit:
www.renesas.com/contact/

Trademarks

Renesas and the Renesas logo are trademarks of Renesas Electronics Corporation. All trademarks and registered trademarks are the property of their respective owners.