

FEATURES:

- High frequency > 150MHz
- Guaranteed low skew < 150ps (max.) between any two outputs
- Very low duty cycle distortion < 300ps
- High speed: propagation delay < 3ns
- Very low CMOS power levels
- TTL compatible inputs and outputs
- 1:10 fanout
- Maximum output rise and fall time < 1.25ns (max.)
- Low input capacitance: 3pF typical
- 2.5V supply voltage
- Available in SSOP and QSOP packages

DESCRIPTION:

The FCT20807 is a 2.5V compatible, high speed, low noise, 1:10 fanout, non-inverting clock buffer. The large fanout from a single input reduces loading on the preceding driver and provides an efficient clock distribution network. Providing output to output skew as low as 150ps, the FCT20807 is an ideal clock distribution device for synchronous systems. Multiple power and grounds reduce noise. Typical applications are clock and signal distribution.

FUNCTIONAL BLOCK DIAGRAM

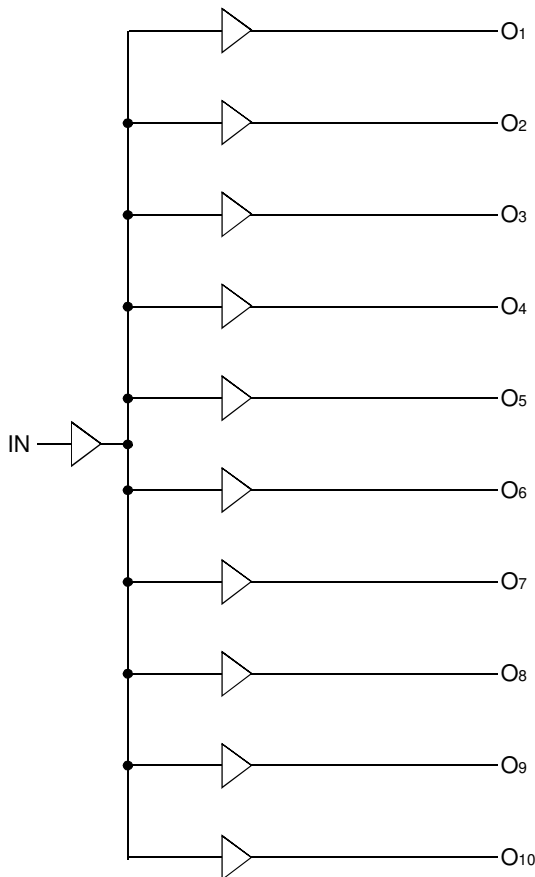

PIN CONFIGURATION

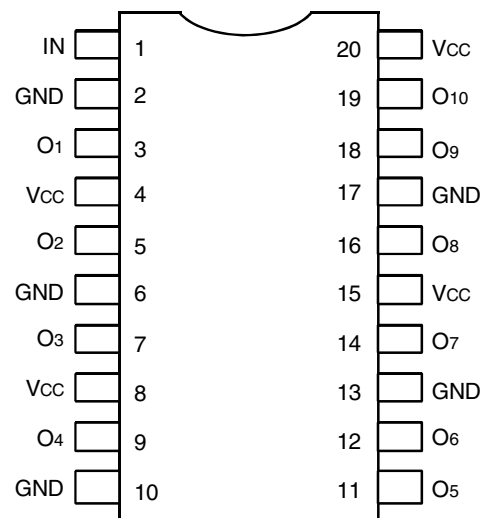

SSOP/ QSOP
TOP VIEW

ABSOLUTE MAXIMUM RATINGS⁽¹⁾

Symbol	Description	Max	Unit
V _{TERM} ⁽²⁾	Terminal Voltage with Respect to GND	-0.5 to +4.6	V
V _{TERM} ⁽³⁾	Terminal Voltage with Respect to GND	-0.5 to +5.5	V
V _{TERM} ⁽⁴⁾	Terminal Voltage with Respect to GND	-0.5 to V _{CC} +0.5	V
T _{STG}	Storage Temperature	-65 to +150	°C
I _{OUT}	DC Output Current	-60 to +60	mA

NOTES:

- Stresses greater than those listed under ABSOLUTE MAXIMUM RATINGS may cause permanent damage to the device. This is a stress rating only and functional operation of the device at these or any other conditions above those indicated in the operational sections of this specification is not implied. Exposure to absolute maximum rating conditions for extended periods may affect reliability.
- V_{CC} terminals.
- Input terminals.
- Outputs and I/O terminals.

CAPACITANCE (T_A = +25°C, f = 1.0MHz)

Symbol	Parameter ⁽¹⁾	Conditions	Typ.	Max.	Unit
C _{IN}	Input Capacitance	V _{IN} = 0V	3	4	pF
C _{OUT}	Output Capacitance	V _{OUT} = 0V	—	6	pF

NOTE:

- This parameter is measured at characterization but not tested.

PIN DESCRIPTION

Pin Names	Description
IN	Clock Inputs
Ox	Clock Outputs

POWER SUPPLY CHARACTERISTICS

Symbol	Parameter	Test Conditions ⁽¹⁾	Min.	Typ. ⁽²⁾	Max.	Unit
I _{CC}	Quiescent Power Supply Current	V _{CC} = Max.	—	0.1	20	μA
I _{CC} H	TTL Inputs HIGH	V _{IN} = GND or V _{CC}	—	—	—	—
ΔI _{CC}	Power Supply Current per Input HIGH	V _{CC} = Max. V _{IN} = V _{CC} - 0.6V	—	45	300	μA
I _{CC} D	Dynamic Power Supply Current per Output ⁽³⁾	V _{CC} = 2.7V 15 pF	—	40	—	μA /MHz
I _C	Total Power Supply Current ⁽⁴⁾	V _{CC} = Max. C _L = 12pF All outputs toggling f _i = 150MHz	—	65	90	mA
		V _{IN} = V _{CC} V _{IN} = GND	—	75	100	

NOTES:

- For conditions shown as Max. or Min., use appropriate value specified under Electrical Characteristics for the applicable device type.
- Typical values are at V_{CC} = 2.5V, +25°C ambient.
- This parameter is not directly testable, but is derived for use in Total Power Supply calculations.
- I_C = I_{QUIESCENT} + I_{INPUTS} + I_{DYNAMIC}
 $I_C = I_{CC} + \Delta I_{CC} \cdot DH_{NT} + I_{CCD}(f_i)$
 I_{CC} = Quiescent Current (I_{CC}L, I_{CC}H and I_{CC}Z)
 ΔI_{CC} = Power Supply Current for a TTL High Input (V_{IN} = V_{CC} - 0.6V)
 DH = Duty Cycle for TTL Inputs High
 NT = Number of TTL Inputs at DH
 I_{CCD} = Dynamic Current Caused by an Input Transition Pair (HLH or LHL)
 f_i = Input Frequency

DC ELECTRICAL CHARACTERISTICS OVER OPERATING RANGE

Following Conditions Apply Unless Otherwise Specified

Industrial: $T_A = -40^{\circ}\text{C}$ to $+85^{\circ}\text{C}$, $V_{CC} = 2.5\text{V} \pm 0.2\text{V}$

Symbol	Parameter	Test Conditions ⁽¹⁾	Min.	Typ. ⁽²⁾	Max.	Unit	
V_{IH}	Input HIGH Level		1.7	—	—	V	
V_{IL}	Input LOW Level		—	—	0.7	V	
I_{IH}	Input HIGH Current (Input pins)	$V_{CC} = \text{Max.}, V_I = V_{CC}$	—	—	± 1	mA	
I_{IL}	Input LOW Current (Input pins)	$V_{CC} = \text{Max.}, V_I = \text{GND}$	—	—	± 1	mA	
V_{IK}	Clamp Diode Voltage	$V_{CC} = \text{Min.}, I_{IN} = -18\text{mA}$	—	-0.7	-1	V	
I_{ODH}	Output HIGH Current	$V_{CC} = 2.5\text{V}, V_{IN} = V_{IH}$ or $V_{IL}, V_O = 1.25\text{V}^{(3)}$	-25	-45	-100	mA	
I_{ODL}	Output LOW Current	$V_{CC} = 2.5\text{V}, V_{IN} = V_{IH}$ or $V_{IL}, V_O = 1.25\text{V}^{(3)}$	20	55	120	mA	
V_{OH}	Output HIGH Voltage	$V_{CC} = \text{Min.}$	$I_{OH} = -1\text{mA}$	$V_{CC}-0.2$	—	—	V
		$V_{IN} = V_{IH}$ or V_{IL}	$I_{OH} = -8\text{mA}$	1.8 ⁽⁵⁾	—	—	
V_{OL}	Output LOW Voltage	$V_{CC} = \text{Min.}$	$I_{OL} = 1\text{mA}$	—	—	0.4	V
		$V_{IN} = V_{IH}$ or V_{IL}	$I_{OL} = 8\text{mA}$	—	—	0.6	
I_{OS}	Short Circuit Current ⁽⁴⁾	$V_{CC} = \text{Max.}, V_O = \text{GND}^{(3)}$	-25	-60	-135	mA	

NOTES:

1. For conditions shown as Max. or Min., use appropriate value specified under Electrical Characteristics for the applicable device type.
2. Typical values are at $V_{CC} = 2.5\text{V}$, $+25^{\circ}\text{C}$ ambient.
3. Not more than one output should be shorted at one time. Duration of the test should not exceed one second.
4. This parameter is guaranteed but not tested.
5. $V_{OH} = V_{CC} - 0.6\text{V}$ at rated current.

SWITCHING CHARACTERISTICS OVER OPERATING RANGE^(1,2)

Following Conditions Apply Unless Otherwise Specified

Industrial: T_A = -40°C to +85°C, V_{CC} = 2.5V ± 0.2V

Symbol	Parameter	Conditions ⁽³⁾	Min.	Typ.	Max.	Unit
t _{PLH} t _{PHL}	Propagation Delay	CL = 22pF 100 MHz	—	3	3.5	ns
t _R	Output Rise Time		—	1	1.25	ns
t _F	Output Fall Time		—	1	1.25	ns
t _{SK(O)}	Same Device Output Pin-to-Pin Skew ⁽⁴⁾		—	100	150	ps
t _{SK(P)}	Pulse Skew ⁽⁵⁾		—	250	300	ps
t _{SK(PP)}	Part-to-Part Skew ⁽⁶⁾		—	400	600	ps

Symbol	Parameter	Conditions ^(3,7)	Min.	Typ.	Max.	Unit
t _{PLH} t _{PHL}	Propagation Delay	CL = 12pF 150 MHz	—	2.4	2.7	ns
t _R	Output Rise Time		—	1	1.2	ns
t _F	Output Fall Time		—	1	1.2	ns
t _{SK(O)}	Same Device Output Pin-to-Pin Skew ⁽⁴⁾		—	100	150	ps
t _{SK(P)}	Pulse Skew ⁽⁵⁾		—	250	300	ps
t _{SK(PP)}	Part-to-Part Skew ⁽⁶⁾		—	400	600	ps

NOTES:

- t_{PLH} and t_{PHL} are production tested. All other parameters guaranteed but not production tested.
- Propagation delay range indicated by Min. and Max. limit is due to V_{CC}, operating temperature and process parameters. These propagation delay limits do not imply skew.
- See test circuits and waveforms.
- Skew measured between all outputs under identical transitions and load conditions.
- Skew measured is difference between propagation delay times t_{PHL} and t_{PLH} of same output under identical load conditions.
- Part to part skew for all outputs given identical transitions and load conditions at identical V_{CC} levels and temperature.
- Airflow of 1m/s is recommended for frequencies above 133MHz.

TEST CIRCUITS AND WAVEFORMS

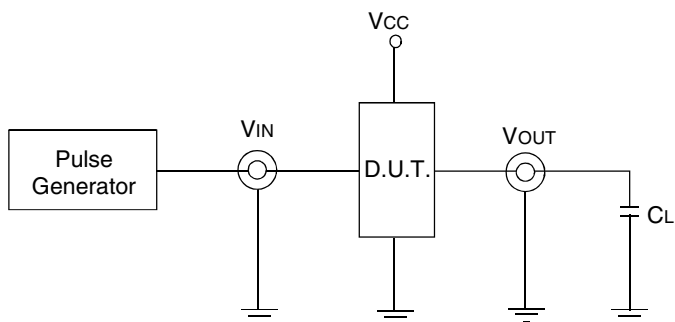

C_L = Load Capacitance: Includes Jig and Probe Capacitance

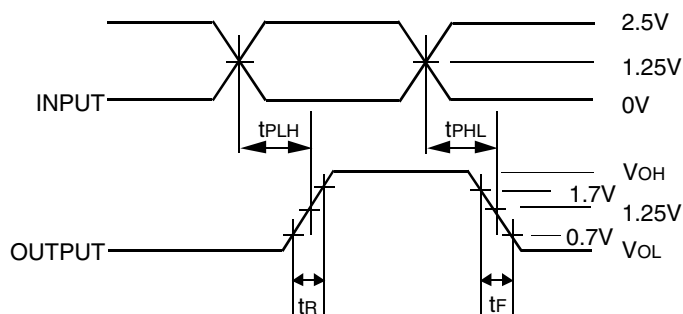

Propagation Delay

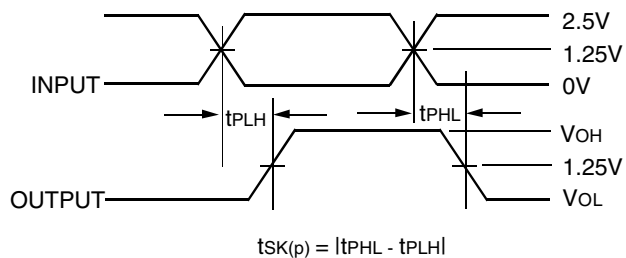

$$t_{SK(P)} = |t_{PHL} - t_{PLH}|$$

Pulse Skew - $t_{SK(P)}$

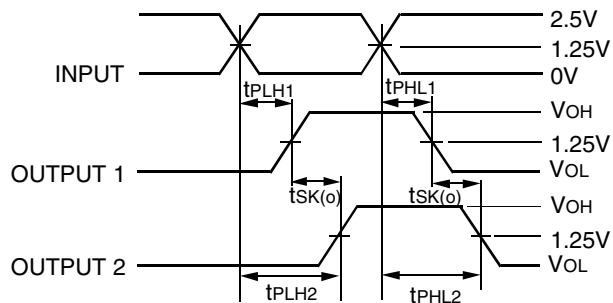

$$t_{SK(O)} = |t_{PLH2} - t_{PLH1}| \text{ or } |t_{PHL2} - t_{PHL1}|$$

Output Skew - $t_{SK(O)}$

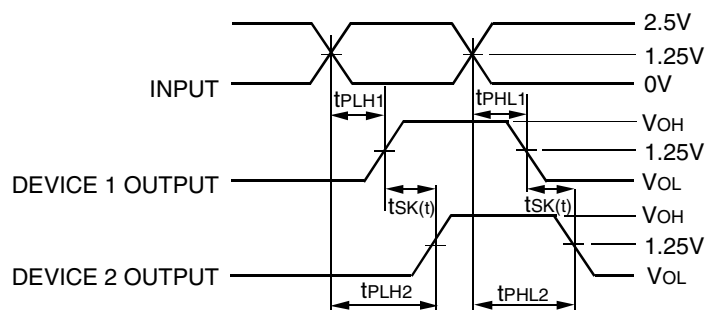

$$t_{SK(t)} = |t_{PLH2} - t_{PLH1}| \text{ or } |t_{PHL2} - t_{PHL1}|$$

Part-to-Part Skew - $t_{SK(PP)}$

NOTE: Device 1 and device 2 are same package type and speed grade.

TEST CONDITIONS

Symbol	$V_{CC} = 2.5V \pm 0.2V$	Unit
CL	22 ⁽¹⁾	pF
	12 ⁽²⁾	
RT	Z _{out} of pulse generator	Ω
tr / tf	1.25 ⁽¹⁾	ns
	1.2 ⁽²⁾	

DEFINITIONS:

CL = Load capacitance: includes jig and probe capacitance.
 RT = Termination resistance: should be equal to Z_{out} of the Pulse Generator.
 tr / tf = Rise/Fall time of the input stimulus from the Pulse Generator.

NOTES:

1. Test conditions at 100MHz.
2. Test conditions at 150MHz.

ORDERING INFORMATION

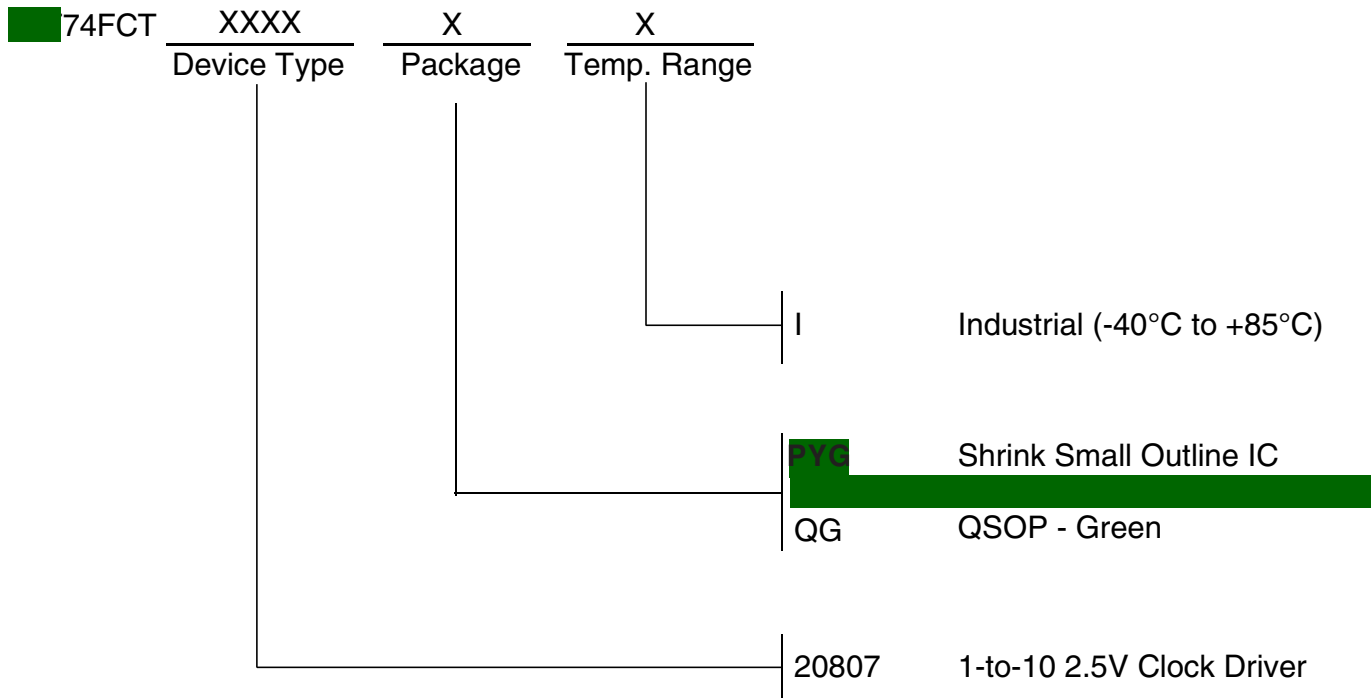

IMPORTANT NOTICE AND DISCLAIMER

RENESAS ELECTRONICS CORPORATION AND ITS SUBSIDIARIES (“RENESAS”) PROVIDES TECHNICAL SPECIFICATIONS AND RELIABILITY DATA (INCLUDING DATASHEETS), DESIGN RESOURCES (INCLUDING REFERENCE DESIGNS), APPLICATION OR OTHER DESIGN ADVICE, WEB TOOLS, SAFETY INFORMATION, AND OTHER RESOURCES “AS IS” AND WITH ALL FAULTS, AND DISCLAIMS ALL WARRANTIES, EXPRESS OR IMPLIED, INCLUDING, WITHOUT LIMITATION, ANY IMPLIED WARRANTIES OF MERCHANTABILITY, FITNESS FOR A PARTICULAR PURPOSE, OR NON-INFRINGEMENT OF THIRD PARTY INTELLECTUAL PROPERTY RIGHTS.

These resources are intended for developers skilled in the art designing with Renesas products. You are solely responsible for (1) selecting the appropriate products for your application, (2) designing, validating, and testing your application, and (3) ensuring your application meets applicable standards, and any other safety, security, or other requirements. These resources are subject to change without notice. Renesas grants you permission to use these resources only for development of an application that uses Renesas products. Other reproduction or use of these resources is strictly prohibited. No license is granted to any other Renesas intellectual property or to any third party intellectual property. Renesas disclaims responsibility for, and you will fully indemnify Renesas and its representatives against, any claims, damages, costs, losses, or liabilities arising out of your use of these resources. Renesas' products are provided only subject to Renesas' Terms and Conditions of Sale or other applicable terms agreed to in writing. No use of any Renesas resources expands or otherwise alters any applicable warranties or warranty disclaimers for these products.

(Disclaimer Rev.1.0 Mar 2020)

Corporate Headquarters

TOYOSU FORESIA, 3-2-24 Toyosu,
Koto-ku, Tokyo 135-0061, Japan
www.renesas.com

Contact Information

For further information on a product, technology, the most up-to-date version of a document, or your nearest sales office, please visit:
www.renesas.com/contact/

Trademarks

Renesas and the Renesas logo are trademarks of Renesas Electronics Corporation. All trademarks and registered trademarks are the property of their respective owners.