

**8.4 W / 30 W peak power offline flyback converter using VIPER38HD**

Data brief

**Features**

- US input range: 85 – 132 V<sub>AC</sub>, frequency: 50 – 60 Hz
- Output voltage / current: 12 V / 0.7 A (2.5 A peak)
- Very compact size
- Standby mains consumption: lower than 25 mW at 115 V<sub>AC</sub>
- Min. active mode efficiency: 81.14%
- Min. active mode at 10% load efficiency: 71.14%
- EMI: according to EN55022-Class-B
- RoHS compliant

**Description**

The STEVAL-ISA182V1 evaluation board implements an isolated flyback converter (12 V / 0.7 A) 8.4 W (30 W peak), US range 85 – 132 V<sub>AC</sub>, developed for metering.

The core of the application is the VIPER38HD, the latest offline converter from the VIPerPlus family. The device is a high-voltage converter that intelligently integrates an 800 V rugged power MOSFET with PWM current-mode control. The device features an adjustable extra power timer (EPT) that enables the IC to sustain overload conditions for a few seconds.

The main characteristics of the evaluation board are its small size, minimal BoM, high efficiency and low standby consumption. Extremely low consumption under the no-load condition is ensured thanks to burst mode operation that reduces the average switching frequency and minimizes all frequency related losses.

VIPER38HD operates at 115 kHz fixed frequency. Frequency jittering is implemented to help meet the standards regarding electromagnetic disturbance. The IC features high-level protections like dual-level OCP, output overvoltage, short-circuits and thermal shutdown with hysteresis. After the removal of a fault condition, the IC is automatically restarted.

# 1 Schematic diagram

Figure 1: STEVAL-ISA182V1 circuit schematic

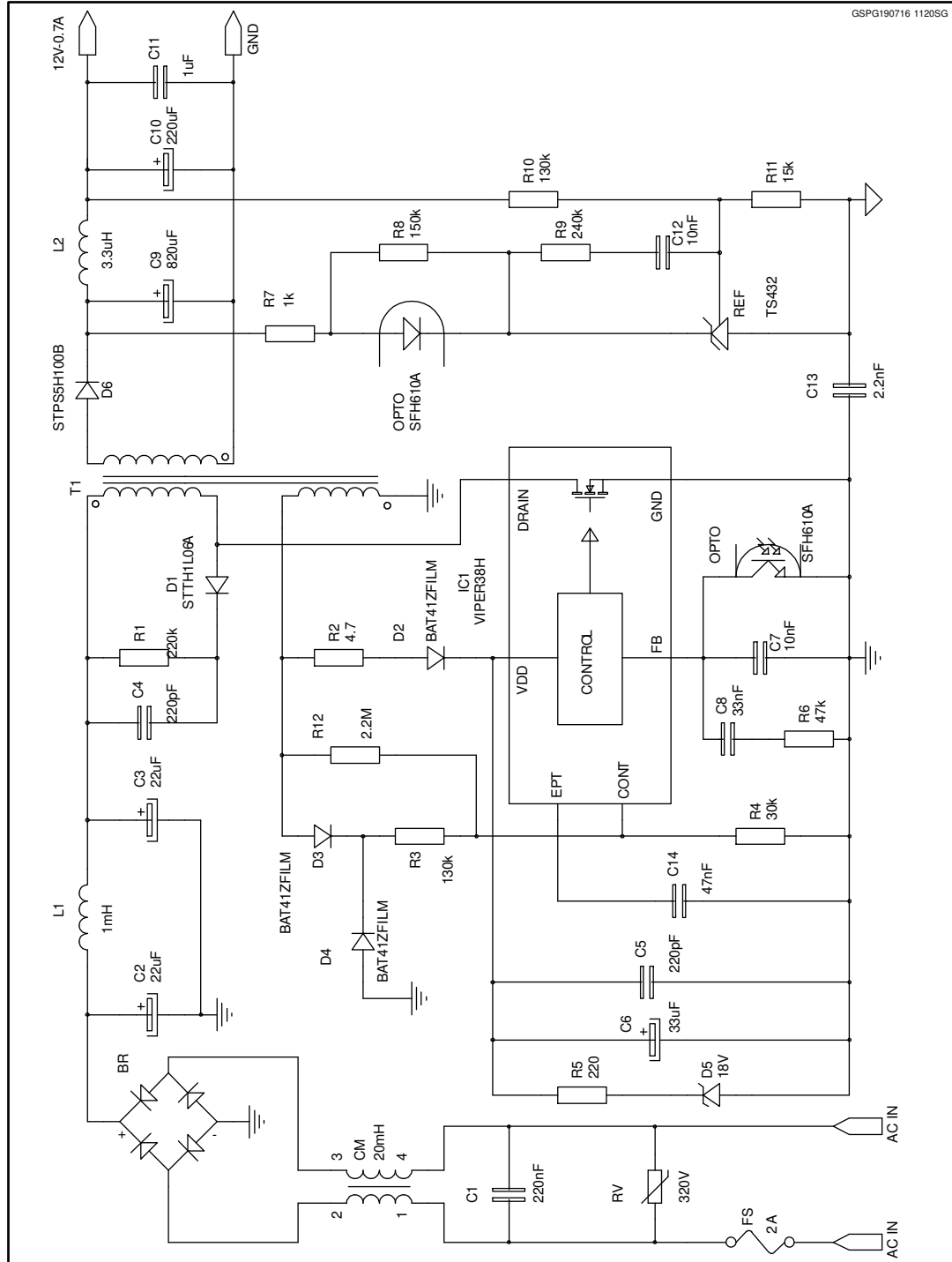

## 2 Revision history

Table 1: Document revision history

Date	Version	Changes
03-Oct-2016	1	Initial release.

**IMPORTANT NOTICE – PLEASE READ CAREFULLY**

STMicroelectronics NV and its subsidiaries ("ST") reserve the right to make changes, corrections, enhancements, modifications, and improvements to ST products and/or to this document at any time without notice. Purchasers should obtain the latest relevant information on ST products before placing orders. ST products are sold pursuant to ST's terms and conditions of sale in place at the time of order acknowledgement.

Purchasers are solely responsible for the choice, selection, and use of ST products and ST assumes no liability for application assistance or the design of Purchasers' products.

No license, express or implied, to any intellectual property right is granted by ST herein.

Resale of ST products with provisions different from the information set forth herein shall void any warranty granted by ST for such product.

ST and the ST logo are trademarks of ST. All other product or service names are the property of their respective owners.

Information in this document supersedes and replaces information previously supplied in any prior versions of this document.

© 2016 STMicroelectronics – All rights reserved