

UNIT:MM

REVISION INFORMATION

Rev.	Rev. Date	Modified By	Brief Description
A/0	18-07-24	T0721A	NEW DRAWING

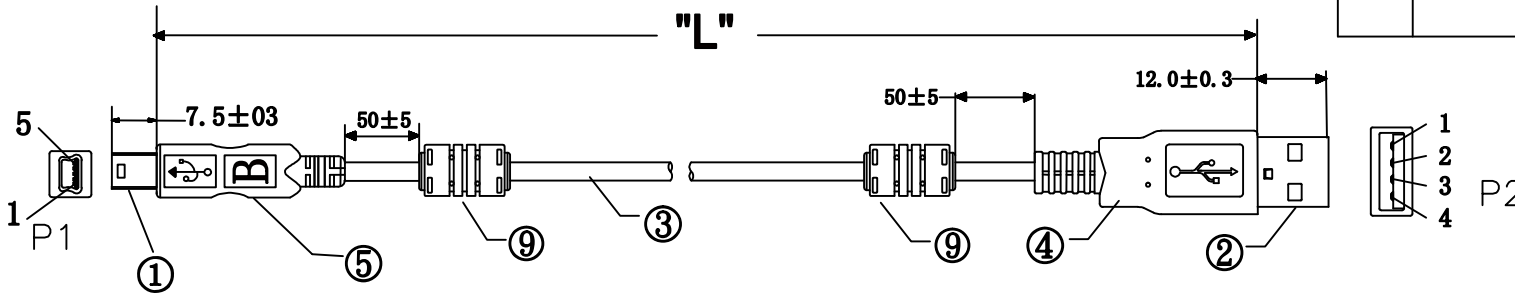

PIN ASSIGNMENT:

P1		P2
1	RED	1
2	WHITE	2
3	GREEN	3
5	BLACK	4
SHELL DRAIN+BRAID		SHELL

Electrical test:

- 100% short, open, miswire test
- Conduct resistance:2 0hm(max)
- Insulation resistance:10Mohm(min)
- dielectric test:DC 300V

CABLE WHITE PRINT

E166160 AWM 2725 80°C 30V
28AWGX1P+28AWGX2C USB2. 0

PART NO	WIRE LENGTH "L"	BUYER COLOR	VENDOR COLOR	CUT LENGTH
102-1031-BL-F0050	500±20		BLACK	500-510MM

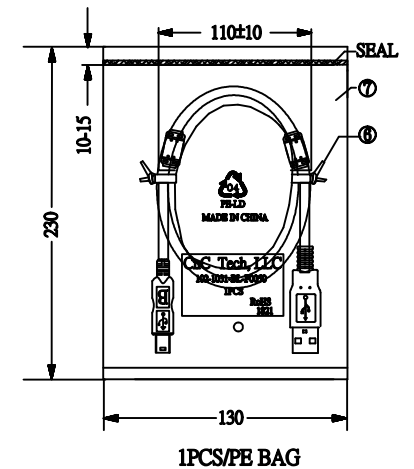

⑨	OUT JACKET	14.5g	BLACK 45P PVC (MOLD NO:CH003)
	FERRITE	2	CORE OD12X5. 6XL20 BLACK
⑧	PE BAG	1/10	CLEAR SIZE:280X330X0. 05mm PRINT BLACK"MADE IN CHINA"+"10PCS"
⑦	PE BAG	1	CLEAR SIZE:130X230X0. 05mm PRINT BLACK"MADE IN CHINA"+"1PC"
⑥	TIE	2	BLACK L=90mm
⑤	OUT JACKET	6g	BLACK PVC-50P (MOULD NO:WM-88)
④	OUT JACKET	6g	BLACK PVC-50P (MOULD NO:2002-527)
③	CABLE	1	BLACK USB2. 0 UL2725 28#/1P+28#/2C+AEB OD:3. 8mm
②	CONN	1set	USB2. 0 A/TYPE MALE SHELL:NICKEL PIN:G/F 4PCS TYPE INSULATOR COLOR:WHITE
①	CONN	1set	USB2. 0 MINI 5P MALE SHELL:NICKEL PIN:G/F 3PCS INSULATOR COLOR:BLACK

NO.	NAME	QTY	SPECIFICATION
-----	------	-----	---------------

CnC Tech, LLC
Industrial Cable and Connector Technology

DRAWN BY:	DATE: 2018/07/24	DESCRIPTION: 4C CABLE USB A/M+MINI 5P/M
CHECKED BY:	SHEET 1 of 1	ITEM NO. As above
APPROVED BY:	SCALE 1:1	REV. A/1 UNIT: mm