

# 1.0 A 6.8 V Dual Motor Driver IC

The 17517 is a monolithic triple totem-pole-output power IC designed to be used in portable electronic applications to control small DC motors and solenoids. The 17517 can operate efficiently with supply voltages as low as 2.0 V to as high as 6.8 V. Its low  $R_{DS(ON)}$  totem-pole output MOSFETs (0.46  $\Omega$  typical) can provide continuous drive currents of 1.0 A and handle peak currents up to 3.0 A. It is easily interfaced to low-cost MCUs via parallel 3.0 V- or 5.0 V-compatible logic. The device can be pulse width modulated (PWM-ed) at up to 200 kHz.

The 17517 can drive two motors in two directions one at a time or drive one motor in two directions and one solenoid with synchronous rectification of freewheeling currents one at a time. Two-motor operation is accomplished by hooking one motor between OUTA and OUTB and hooking the other motor between OUTB and OUTC. Motor plus solenoid operation is accomplished by hooking a motor between OUTA and OUTB and a solenoid between OUTC and GND.

This device contains an integrated charge pump and level shifter (for gate drive voltages), integrated shoot-through current protection (cross-conduction suppression logic and timing), and undervoltage detection and shutdown circuitry.

The 17517 has four operating modes: Forward, Reverse, Brake, and Tri-Stated (High Impedance).

## Features

- 2.0 V to 6.8 V Continuous Operation
- Output Current 1.0 A (DC), 3.0 A (Peak)
- MOSFETs < 600 m $\Omega$   $R_{DS(ON)}$  @ 25°C Guaranteed
- 3.0 V/5.0 V TTL-/CMOS-Compatible Inputs
- PWM Frequencies up to 200 kHz
- Undervoltage Shutdown

**17517**

\*  
**DUAL MOTOR DRIVER**



ORDERING INFORMATION		
Device	Temperature Range (T <sub>A</sub> )	Package
MPC17517DTB/R2	-20°C to 65°C	16 TSSOP

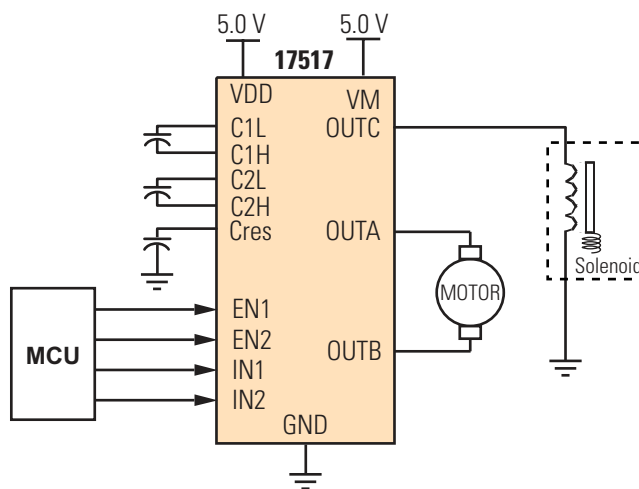

**Figure 1. 17517 Simplified Application Diagram**

\* This document contains certain information on a new product. Specifications and information herein are subject to change without notice.

### INTERNAL BLOCK DIAGRAM

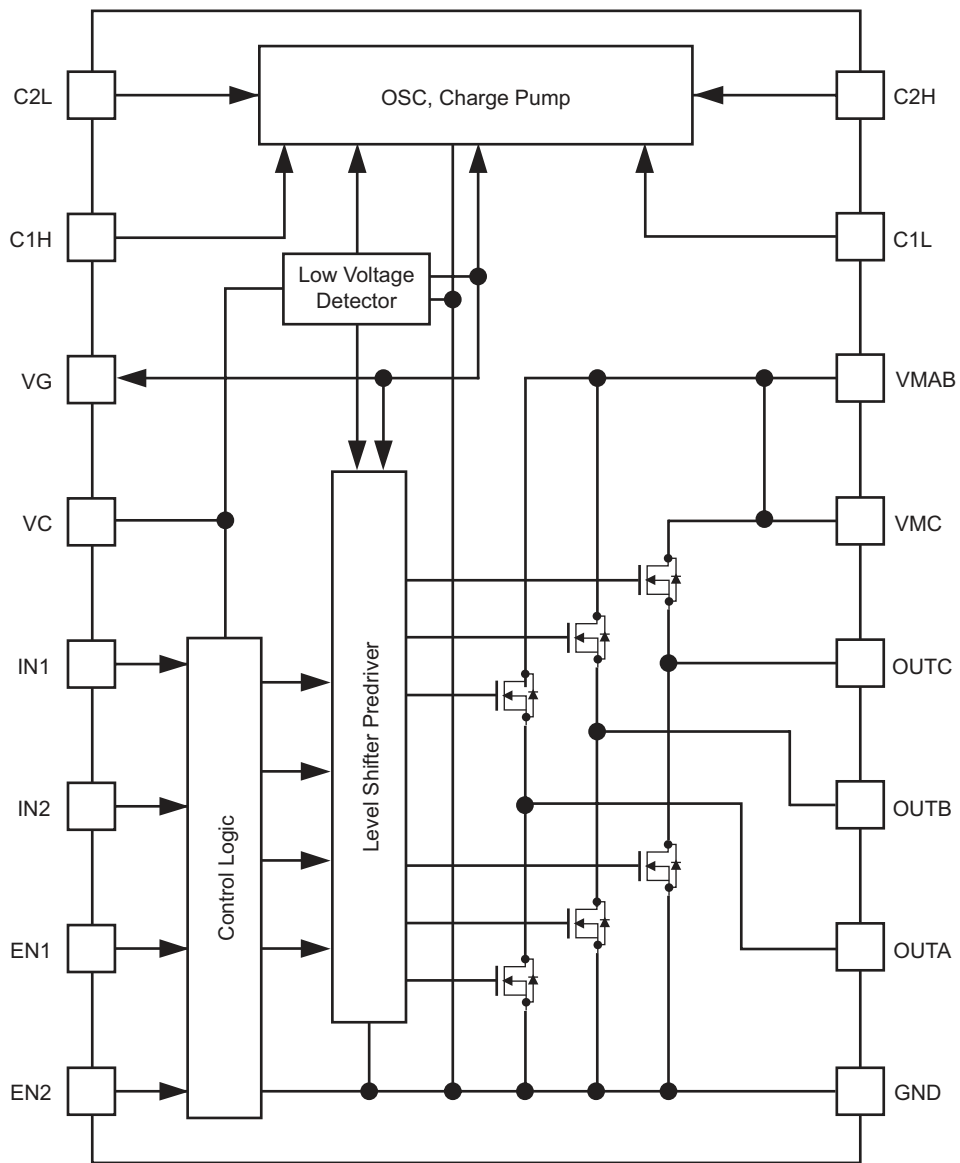
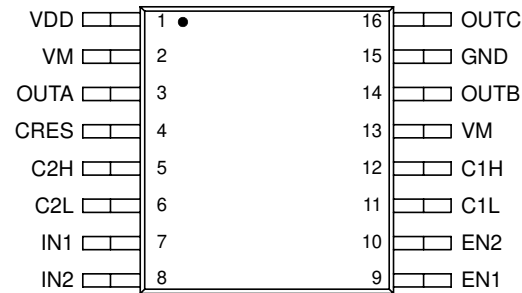

Figure 2. 17517 Simplified Internal Block Diagram

## PIN CONNECTIONS



**Figure 3. 17517 Pin Connections**

**Table 1. 17517 Pin Definitions**

A functional description of each pin can be found in the Functional Pin Description section beginning on [page 9](#).

Pin Number	Pin Name	Formal Name	Definition
1	VDD	Control Circuit Power Supply	Positive power source connection for control circuit.
2, 13	VM	Motor Drive Power Supply	Motor power supply voltage input pins.
3	OUTA	Output A	Driver output A pin.
4	CRES	Charge Pump Output Capacitor Connection	Charge pump reservoir capacitor pin.
5	C2H	Charge Pump 2H	Charge pump bucket capacitor 2 (positive pole).
6	C2L	Charge Pump 2L	Charge pump bucket capacitor 2 (negative pole).
7	IN1	Input Control 1	Control signal input 1 pin.
8	IN2	Input Control 2	Control signal input 2 pin.
9	EN1	Enable Control Signal Input 1	Enable control signal input 1 pin.
10	EN2	Enable Control Signal Input 2	Enable control signal input 2 pin.
11	C1L	Charge Pump 1L	Charge pump bucket capacitor 1 (negative pole).
12	C1H	Charge Pump 1H	Charge pump bucket capacitor 1 (positive pole).
14	OUTB	Output B	Driver output B pin.
15	GND	Ground	Ground connection.
16	OUTC	Output C	Driver output C pin.

## ELECTRICAL CHARACTERISTICS

### MAXIMUM RATINGS

**Table 2. Maximum Ratings**

All voltages are with respect to ground unless otherwise noted. Exceeding these ratings may cause a malfunction or permanent damage to the device.

Ratings	Symbol	Value	Unit
<b>ELECTRICAL RATINGS</b>			
Motor Supply Voltage	$V_M$	-0.5 to 8.0	V
Charge Pump Output Voltage	$V_{CRES}$	-0.5 to 14	V
Logic Supply Voltage	$V_{DD}$	-0.5 to 7.0	V
Signal Input Voltage	$V_{IN}$	-0.5 to $V_{DD}+0.5$	V
Driver Output Current			A
Continuous	$I_O$	1.0	
Peak <sup>(1)</sup>	$I_{OPK}$	3.0	
ESD Voltage <sup>(2)</sup>			V
Human Body Model	$V_{ESD1}$	±2000	
Machine Model	$V_{ESD2}$	±100	
<b>THERMAL RATINGS</b>			
Storage Temperature Range	$T_{STG}$	-65 to 150	°C
Operating Junction Temperature	$T_J$	-20 to 150	°C
Operating Ambient Temperature	$T_A$	-20 to 65	°C
Thermal Resistance <sup>(3)</sup>	$R_{\theta JA}$	190	°C/W
Power Dissipation <sup>(4)</sup>	$P_D$	657	mW
Soldering Temperature <sup>(5)</sup>	$T_{SOLDER}$	245	°C

Notes

- $T_A = 25^\circ\text{C}$ , 10 ms pulse width at 200 ms intervals.
- ESD1 testing is performed in accordance with the Human Body Model ( $C_{ZAP} = 100 \text{ pF}$ ,  $R_{ZAP} = 1500 \text{ }\Omega$ ), ESD2 testing is performed in accordance with the Machine Model ( $C_{ZAP} = 200 \text{ pF}$ ,  $R_{ZAP} = 0 \text{ }\Omega$ ).
- 37 mm x 50 mm Cu area (1.6 mm FR-4 PCB).
- Maximum at  $T_A = 25^\circ\text{C}$ .
- Soldering temperature limit is for 10 seconds maximum duration. Not designed for immersion soldering. Exceeding these limits may cause malfunction or permanent damage to the device.

### STATIC ELECTRICAL CHARACTERISTICS

**Table 3. Static Electrical Characteristics**

Characteristics noted under conditions  $T_A = 25^\circ\text{C}$ ,  $V_{DD} = V_M = 5.0\text{ V}$ ,  $\text{GND} = 0\text{ V}$  unless otherwise noted. Typical values noted reflect the approximate parameter means at  $T_A = 25^\circ\text{C}$  under nominal conditions unless otherwise noted.

Characteristic	Symbol	Min	Typ	Max	Unit
<b>POWER</b>					
Motor Supply Voltage	$V_M$	2.0	5.0	6.8	V
Logic Supply Voltage	$V_{DD}$	2.7	5.0	5.7	V
Capacitor for Charge Pump	C1, C2, C3	0.01	0.1	1.0	$\mu\text{F}$
Standby Power Supply Current					
Motor Supply Standby Current	$I_{V_{MSTBY}}$	–	–	1.0	$\mu\text{A}$
Logic Supply Standby Current <sup>(6)</sup>	$I_{V_{DDSTBY}}$	–	–	1.0	$\text{mA}$
Operating Power Supply Current					$\text{mA}$
Logic Supply Current <sup>(7)</sup>	$I_{V_{DD}}$	–	–	3.0	
Charge Pump Circuit Supply Current	$I_{CRES}$	–	–	0.7	
Low-Voltage Detection Circuit					V
Detection Voltage ( $V_{DD}$ ) <sup>(8)</sup>	$V_{DDDET}$	1.5	2.0	2.5	
Driver Output ON Resistance <sup>(9)</sup>	$R_{DS(ON)}$	–	0.46	0.60	W
<b>GATE DRIVE</b>					
Gate Drive Voltage <sup>(10)</sup>					V
No Current Load	$V_{CRES}$	12	13	13.5	
Gate Drive Ability (Internally Supplied)					V
$I_{CRES} = -1.0\text{ mA}$	$V_{CRESLOAD}$	10	11.2	–	
<b>CONTROL LOGIC</b>					
Logic Input Voltage	$V_{IN}$	0	–	$V_{DD}$	V
Logic Input Function ( $2.7\text{ V} < V_{DD} < 5.7\text{ V}$ )					
High-Level Input Voltage	$V_{IH}$	$V_{DD} \times 0.7$	–	–	V
Low-Level Input Voltage	$V_{IL}$	–	–	$V_{DD} \times 0.3$	V
High-Level Input Current	$I_{IH}$	–	–	1.0	$\mu\text{A}$
Low-Level Input Current	$I_{IL}$	-1.0	–	–	$\mu\text{A}$

**Notes**

- $I_{V_{DDSTBY}}$  includes current to the predriver circuit.
- $I_{V_{DD}}$  includes current to the predriver circuit.
- Detection voltage is defined as when the output becomes high-impedance after  $V_{DD}$  drops below the detection threshold. When the gate voltage  $V_{CRES}$  is applied from an external source,  $V_{CRES} = 7.5\text{ V}$ .
- $I_O = 1.0\text{ A}$  source + sink.
- Input logic signal not present.

### DYNAMIC ELECTRICAL CHARACTERISTICS

**Table 4. Dynamic Electrical Characteristics**

Characteristics noted under conditions  $T_A = 25^\circ\text{C}$ ,  $V_{DD} = V_M = 5.0\text{ V}$ ,  $\text{GND} = 0\text{ V}$  unless otherwise noted. Typical values noted reflect the approximate parameter means at  $T_A = 25^\circ\text{C}$  under nominal conditions unless otherwise noted.

Characteristic	Symbol	Min	Typ	Max	Unit
<b>INPUT (IN1, IN2, EN1, EN2)</b>					
Pulse Input Frequency	$f_{IN}$	–	–	200	kHz
Input Pulse Rise Time <sup>(11)</sup>	$t_R$	–	–	1.0 <sup>(12)</sup>	$\mu\text{s}$
Input Pulse Fall Time <sup>(13)</sup>	$t_F$	–	–	1.0 <sup>(12)</sup>	$\mu\text{s}$
<b>OUTPUT</b>					
Propagation Delay Time					$\mu\text{s}$
Turn-ON Time	$t_{PLH}$	–	0.1	0.5	
Turn-OFF Time	$t_{PHL}$	–	0.1	0.5	
Charge Pump Wake-Up Time <sup>(14)</sup>	$t_{VGON}$	–	0.1	3.0	ms
Low-Voltage Detection Time	$t_{V_{DD}DET}$	–	–	10	ms

**Notes**

11. Time is defined between 10% and 90%.
12. That is, the input waveform slope must be steeper than this.
13. Time is defined between 90% and 10%.
14. When  $C1 = C2 = C3 = 0.1\ \mu\text{F}$ .

**TIMING DIAGRAMS**

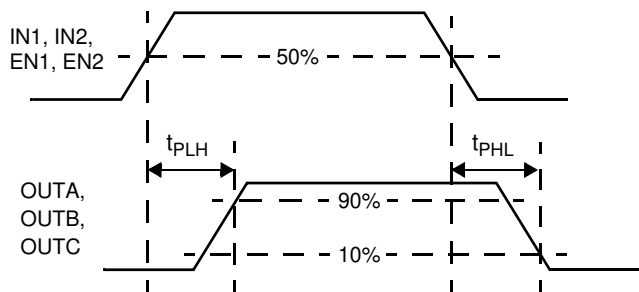

**Figure 4.  $t_{PLH}$ ,  $t_{PHL}$ , and  $t_{PZH}$  Timing**

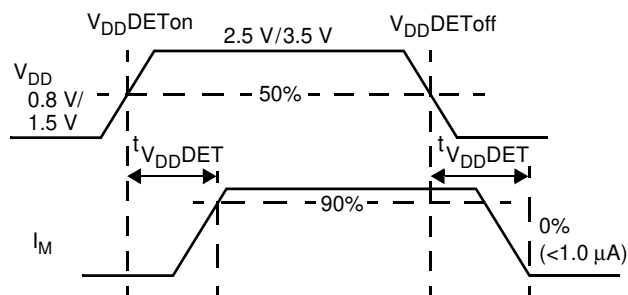

**Figure 5. Low-Voltage Detection Timing**

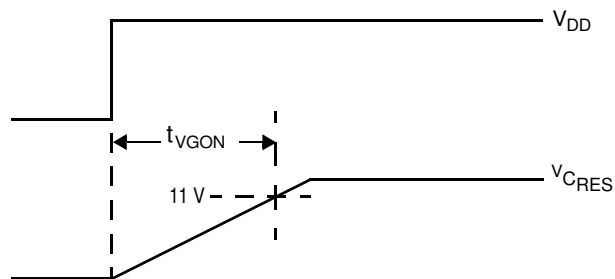

**Figure 6. Charge Pump Timing**

**Table 5. Truth Table**

INPUT				OUTPUT		
IN1	IN2	EN1	EN2	OUTA	OUTB	OUTC

**SHUTDOWN MODE**

X	X	L	L	Z	Z	Z
---	---	---	---	---	---	---

**CHANNEL 1 (A-B) DRIVING MODE**

H	H	H	L	L	L	Z
H	L	H	L	H	L	Z
L	H	H	L	L	H	Z
L	L	H	L	Z	Z	Z

**CHANNEL 2 (B-C) DRIVING MODE**

H	H	L	H	Z	L	L
H	L	L	H	Z	H	L
L	H	L	H	Z	L	H
L	L	L	H	Z	Z	Z

**HALF-BRIDGE (C) DRIVING MODE**

H	H	H	H	Z	Z	Z
H	L	H	H	Z	Z	H
L	H	H	H	Z	Z	L
L	L	H	H	Z	Z	Z

H = High.  
L = Low.  
Z = High impedance.  
X = Don't care.



## FUNCTIONAL DESCRIPTION

### INTRODUCTION

The 17517 is a triple totem-pole output H-Bridge power IC designed to drive small dc motors used in portable electronics. The 17517 can operate efficiently with supply voltages as low as 2.0 V to as high as 6.8 V, and provide continuous motor drive currents of 1.0 A while handling peak currents up to 3.0 A. It is easily interfaced to low cost MCUs via parallel 3.0 V- or 5.0 V-compatible logic. The device can be pulse width modulated (PWM-ed) at up to 200 kHz. The 17517 can drive two motors in two directions one at a time; or it can drive one motor in two directions and one solenoid with synchronous rectification of freewheeling currents one at a time. Two-motor operation is accomplished by hooking one motor between OUTA and OUTB, and the other motor between OUTB and OUTC. Motor + solenoid operation is accomplished by hooking a motor between OUTA and OUTB

and placing a solenoid between OUTC and GND. [Table 5. Truth Table](#), page 8, describes the operating states versus the input conditions.

As shown in [Figure 2. 17517 Simplified Internal Block Diagram](#), page 2, the 17517 is a monolithic triple totem-pole output bridge with built-in charge pump circuitry. Each of the six MOSFETs forming the triple totem-pole output has an  $R_{DS(ON)}$  of  $\leq 0.6 \Omega$  (guaranteed by design). The IC has an integrated charge pump and level shifter (for gate drive voltages). Additionally, the IC has a built-in shoot-through current protection circuit and undervoltage lockout function. This IC has four operating modes: Forward, Reverse, Brake, and Tri-States (High Impedance).

### FUNCTIONAL PIN DESCRIPTION

#### DRIVER OUTPUT (OUTA, OUTB, OUTC)

These pins provide the connection to the internal power MOSFET triple-totem-pole H-bridge of the IC.

#### GROUND (GND)

Power and signal ground pin.

#### CHARGE PUMP OUTPUT CAPACITOR (CRES)

This pin provides the connection for the external reservoir capacitor (output of the charge pump). Alternatively, this pin can also be used as an input to supply gate-drive voltage from an external source via a series current-limiting resistor.

The voltage at the CRES pin will be approximately three times the  $V_{DD}$  voltage, as the internal charge pump utilizes a voltage tripler circuit. The  $V_{DDRES}$  voltage is used by the IC to supply gate drive for the internal power MOSFETs.

#### MOTOR DRIVE POWER SUPPLY (VM)

The two VM pins carry the main supply voltage and current into the power sections of the IC. This supply then becomes controlled and/or modulated by the IC as it delivers the power to the load attached between OUTA and OUTB.

The VM pins must be connected together on the printed circuit board with as short as possible traces offering as low impedance as possible between pins.

#### CONTROL SIGNAL INPUT AND ENABLE CONTROL SIGNAL INPUT (IN1, IN1, EN1, EN2)

These pins are input control pins used to control the outputs. These pins are 3.0 V/5.0 V CMOS-compatible inputs with hysteresis. These pins work together to control OUTA, OUTB, and OUTC (refer to [Table 5. Truth Table](#)).

#### CHARGE PUMP BUCKET CAPACITOR (C1L, C1H, C2L, C2H)

These two pairs of pins, the C1L and C1H and the C2L and C2H, connect to the external bucket capacitors required by the internal charge pump. The typical value for the bucket capacitors is 0.1  $\mu\text{F}$ .

#### CONTROL CIRCUIT POWER SUPPLY (VDD)

This pin carries the logic supply voltage and current into the logic sections of the IC.  $V_{DD}$  has an undervoltage threshold. If the supply voltage drops below the undervoltage threshold, the output power stage switches to a tri-state condition. When the supply voltage returns to a level that is above the threshold, the power stage automatically resumes normal operation according to the established condition of the input pins.

## TYPICAL APPLICATIONS

### INTRODUCTION

Figure 7 shows a typical application for the 17517. When applying the gate voltage to the C<sub>RES</sub> pin from an external source, be sure to connect it via a resistor equal to, or greater than,  $R_G = V_{C_{RES}}/0.02 \Omega$ .

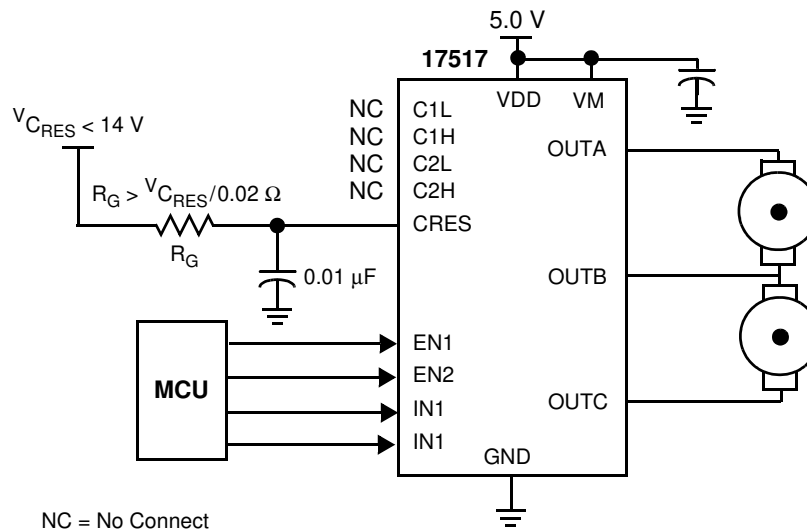

Figure 7. 17517 Typical Application Diagram

### CEMF SNUBBING TECHNIQUES

Care must be taken to protect the IC from potentially damaging CEMF spikes induced when commutating currents in inductive loads. Typical practice is to provide snubbing of voltage transients by placing a capacitor or zener at the supply pin (VM) (see Figure 8).

### PCB LAYOUT

When designing the printed circuit board (pcb), connect sufficient capacitance between power supply and ground pins to ensure proper filtering from transients. For all high-current paths, use wide copper traces and shortest possible distances.

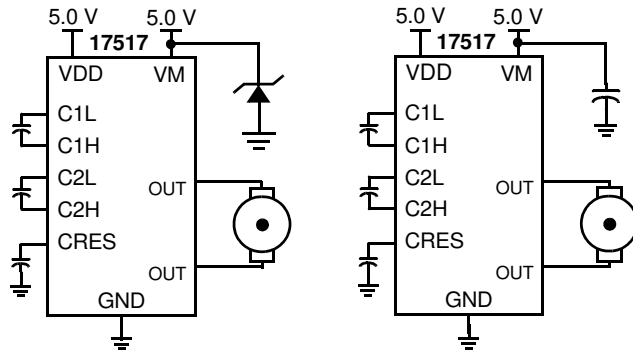
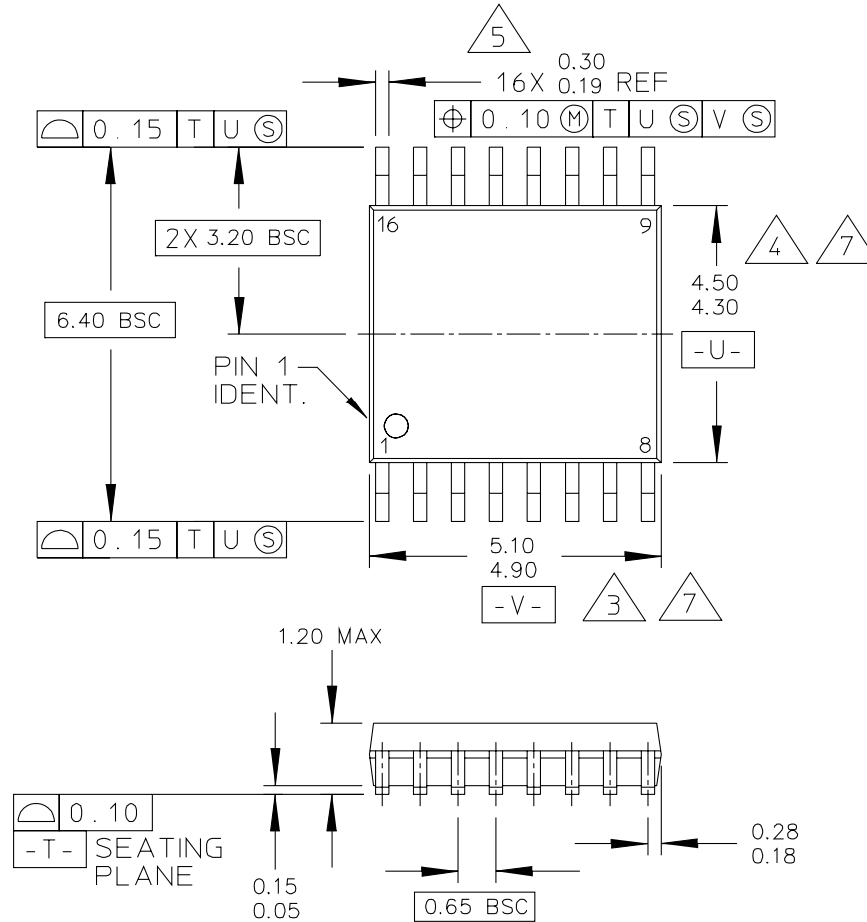

Figure 8. CEMF Snubbing Techniques

# PACKAGING

## PACKAGE DIMENSIONS

For the most current package revision, visit [www.freescale.com](http://www.freescale.com) and perform a keyword search using the "98A" listed below.



© FREESCALE SEMICONDUCTOR, INC. ALL RIGHTS RESERVED.	MECHANICAL OUTLINE	PRINT VERSION NOT TO SCALE	
TITLE:  16 LD TSSOP, PITCH 0.65MM	DOCUMENT NO: 98ASH70247A	REV: B	
	CASE NUMBER: 948F-01	19 MAY 2005	
	STANDARD: JEDEC		

**DTB SUFFIX**  
16-PIN  
PLASTIC PACKAGE  
98ASH70247A  
ISSUE B

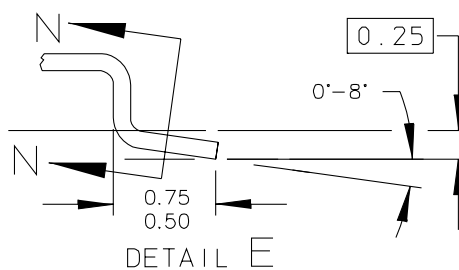
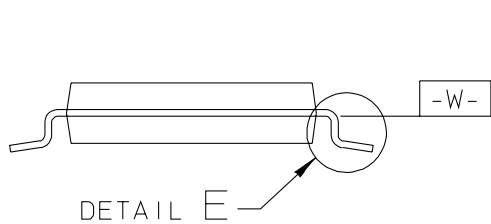
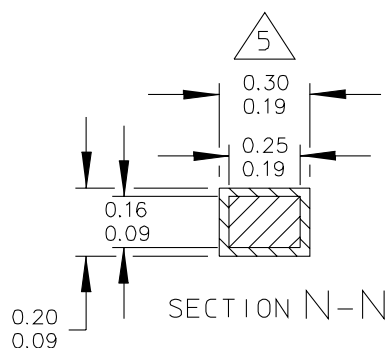

© FREESCALE SEMICONDUCTOR, INC. ALL RIGHTS RESERVED.	MECHANICAL OUTLINE	PRINT VERSION NOT TO SCALE	
TITLE:  16 LD TSSOP, PITCH 0.65MM	DOCUMENT NO: 98ASH70247A	REV: B	
	CASE NUMBER: 948F-01	19 MAY 2005	
	STANDARD: JEDEC		

**DTB SUFFIX**  
16-PIN  
PLASTIC PACKAGE  
98ASH70247A  
ISSUE B

## REVISION HISTORY

REVISION	DATE	DESCRIPTION OF CHANGES
2.0	7/2006	<ul style="list-style-type: none"><li>• Implemented Revision History page</li><li>• Converted to Freescale format and updated to the prevailing form and style</li></ul>

## **How to Reach Us:**

### **Home Page:**

[www.freescale.com](http://www.freescale.com)

### **E-mail:**

[support@freescale.com](mailto:support@freescale.com)

### **USA/Europe or Locations Not Listed:**

Freescale Semiconductor  
Technical Information Center, CH370  
1300 N. Alma School Road  
Chandler, Arizona 85224  
+1-800-521-6274 or +1-480-768-2130  
[support@freescale.com](mailto:support@freescale.com)

### **Europe, Middle East, and Africa:**

Freescale Halbleiter Deutschland GmbH  
Technical Information Center  
Schatzbogen 7  
81829 Muenchen, Germany  
+44 1296 380 456 (English)  
+46 8 52200080 (English)  
+49 89 92103 559 (German)  
+33 1 69 35 48 48 (French)  
[support@freescale.com](mailto:support@freescale.com)

### **Japan:**

Freescale Semiconductor Japan Ltd.  
Headquarters  
ARCO Tower 15F  
1-8-1, Shimo-Meguro, Meguro-ku,  
Tokyo 153-0064  
Japan  
0120 191014 or +81 3 5437 9125  
[support.japan@freescale.com](mailto:support.japan@freescale.com)

### **Asia/Pacific:**

Freescale Semiconductor Hong Kong Ltd.  
Technical Information Center  
2 Dai King Street  
Tai Po Industrial Estate  
Tai Po, N.T., Hong Kong  
+800 2666 8080  
[support.asia@freescale.com](mailto:support.asia@freescale.com)

### **For Literature Requests Only:**

Freescale Semiconductor Literature Distribution Center  
P.O. Box 5405  
Denver, Colorado 80217  
1-800-441-2447 or 303-675-2140  
Fax: 303-675-2150  
[LDCForFreescaleSemiconductor@hibbertgroup.com](mailto:LDCForFreescaleSemiconductor@hibbertgroup.com)

RoHS-compliant and/or Pb-free versions of Freescale products have the functionality and electrical characteristics of their non-RoHS-compliant and/or non-Pb-free counterparts. For further information, see <http://www.freescale.com> or contact your Freescale sales representative.

For information on Freescale's Environmental Products program, go to <http://www.freescale.com/epp>.

Information in this document is provided solely to enable system and software implementers to use Freescale Semiconductor products. There are no express or implied copyright licenses granted hereunder to design or fabricate any integrated circuits or integrated circuits based on the information in this document.

Freescale Semiconductor reserves the right to make changes without further notice to any products herein. Freescale Semiconductor makes no warranty, representation or guarantee regarding the suitability of its products for any particular purpose, nor does Freescale Semiconductor assume any liability arising out of the application or use of any product or circuit, and specifically disclaims any and all liability, including without limitation consequential or incidental damages. "Typical" parameters that may be provided in Freescale Semiconductor data sheets and/or specifications can and do vary in different applications and actual performance may vary over time. All operating parameters, including "Typicals", must be validated for each customer application by customer's technical experts. Freescale Semiconductor does not convey any license under its patent rights nor the rights of others. Freescale Semiconductor products are not designed, intended, or authorized for use as components in systems intended for surgical implant into the body, or other applications intended to support or sustain life, or for any other application in which the failure of the Freescale Semiconductor product could create a situation where personal injury or death may occur. Should Buyer purchase or use Freescale Semiconductor products for any such unintended or unauthorized application, Buyer shall indemnify and hold Freescale Semiconductor and its officers, employees, subsidiaries, affiliates, and distributors harmless against all claims, costs, damages, and expenses, and reasonable attorney fees arising out of, directly or indirectly, any claim of personal injury or death associated with such unintended or unauthorized use, even if such claim alleges that Freescale Semiconductor was negligent regarding the design or manufacture of the part.

Freescale™ and the Freescale logo are trademarks of Freescale Semiconductor, Inc. All other product or service names are the property of their respective owners.

© Freescale Semiconductor, Inc., 2006. All rights reserved.