

74CBTLV1G125

Single bus switch

Rev. 4 — 5 September 2012

Product data sheet

1. General description

The 74CBTLV1G125 provides a single high-speed line switch. The switch is disabled when the output enable (\overline{OE}) input is high.

To ensure the high-impedance OFF-state during power-up or power-down, tie \overline{OE} to the V_{CC} through a pull-up resistor. The current-sinking capability of the driver determines the minimum value of the resistor.

Schmitt trigger action at control input makes the circuit tolerant to slower input rise and fall times across the entire V_{CC} range from 2.3 V to 3.6 V.

This device is fully specified for partial power-down applications using I_{OFF} . The I_{OFF} circuitry disables the output, preventing the damaging backflow current through the device when it is powered down.

2. Features and benefits

- Supply voltage range from 2.3 V to 3.6 V
- High noise immunity
- Complies with JEDEC standard:
 - ◆ JESD8-5 (2.3 V to 2.7 V)
 - ◆ JESD8-B/JESD36 (2.7 V to 3.6 V)
- ESD protection:
 - ◆ HBM JESD22-A114F exceeds 2000 V
 - ◆ MM JESD22-A115-A exceeds 200 V
 - ◆ CDM JESD22-C101E exceeds 1000 V
- 5 Ω switch connection between two ports
- Rail to rail switching on data I/O ports
- CMOS low power consumption
- Latch-up performance meets requirements of JESD78 Class I
- I_{OFF} circuitry provides partial power-down mode operation
- Multiple package options
- Specified from $-40\text{ }^{\circ}\text{C}$ to $+85\text{ }^{\circ}\text{C}$ and $-40\text{ }^{\circ}\text{C}$ to $+125\text{ }^{\circ}\text{C}$



3. Ordering information

Table 1. Ordering information

Type number	Package			Version
	Temperature range	Name	Description	
74CBTLV1G125GW	-40 °C to +125 °C	TSSOP5	plastic thin shrink small outline package; 5 leads; body width 1.25 mm	SOT353-1
74CBTLV1G125GV	-40 °C to +125 °C	SC-74A	plastic surface-mounted package; 5 leads	SOT753
74CBTLV1G125GM	-40 °C to +125 °C	XSON6	plastic extremely thin small outline package; no leads; 6 terminals; body 1 × 1.45 × 0.5 mm	SOT886
74CBTLV1G125GF	-40 °C to +125 °C	XSON6	plastic extremely thin small outline package; no leads; 6 terminals; body 1 × 1 × 0.5 mm	SOT891
74CBTLV1G125GN	-40 °C to +125 °C	XSON6	extremely thin small outline package; no leads; 6 terminals; body 0.9 × 1.0 × 0.35 mm	SOT1115
74CBTLV1G125GS	-40 °C to +125 °C	XSON6	extremely thin small outline package; no leads; 6 terminals; body 1.0 × 1.0 × 0.35 mm	SOT1202

4. Marking

Table 2. Marking

Type number	Marking code ^[1]
74CBTLV1G125GW	bM
74CBTLV1G125GV	b25
74CBTLV1G125GM	bM
74CBTLV1G125GF	bM
74CBTLV1G125GN	bM
74CBTLV1G125GS	bM

[1] The pin 1 indicator is located on the lower left corner of the device, below the marking code.

5. Functional diagram

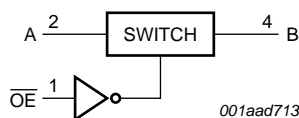

Fig 1. Logic symbol

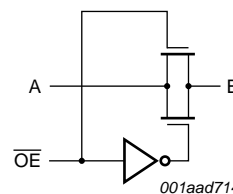
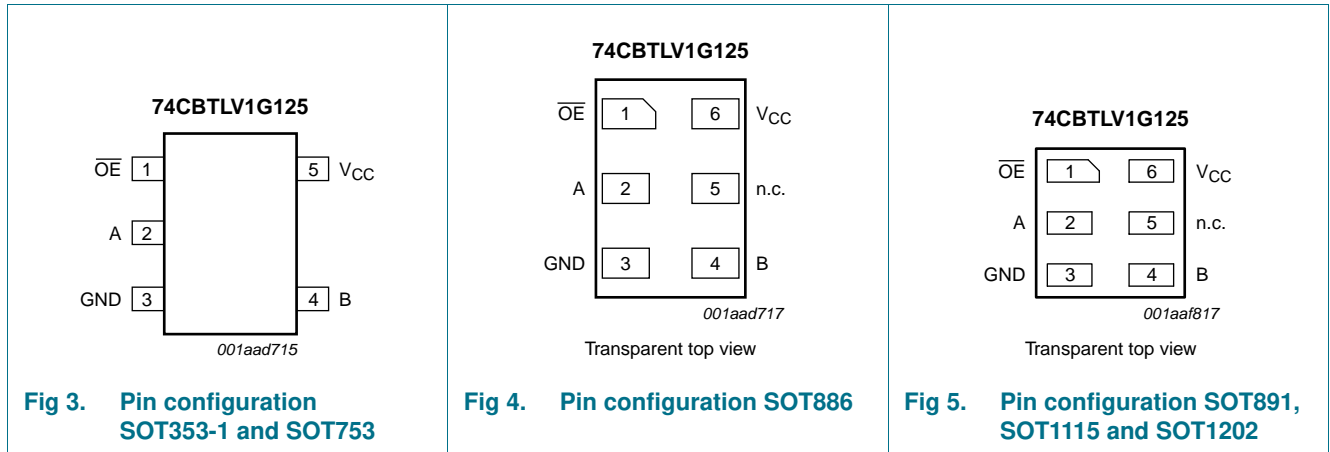

Fig 2. Logic diagram

6. Pinning information

6.1 Pinning



6.2 Pin description

Table 3. Pin description

Symbol	Pin		Description
	SOT353-1, SOT753	SOT886, SOT891, SOT1115 and SOT1202	
\overline{OE}	1	1	output enable input \overline{OE} (active LOW)
A	2	2	data input or output A
GND	3	3	ground (0 V)
B	4	4	data input or output B
n.c.	-	5	not connected
V _{CC}	5	6	supply voltage

7. Functional description

7.1 Function table

Table 4. Function table^[1]

Output enable input \overline{OE}	Function switch
L	ON-state
H	OFF-state

[1] H = HIGH voltage level; L = LOW voltage level.

8. Limiting values

Table 5. Limiting values

In accordance with the Absolute Maximum Rating System (IEC 60134). Voltages are referenced to GND (ground = 0 V).

Symbol	Parameter	Conditions	Min	Max	Unit
V_{CC}	supply voltage		-0.5	+4.6	V
V_I	input voltage		[1] -0.5	+4.6	V
V_{SW}	switch voltage	enable and disable mode	-0.5	$V_{CC} + 0.5$	V
I_{IK}	input clamping current	$V_{IO} < -0.5$ V	-50	-	mA
I_{SK}	switch clamping current	$V_I < -0.5$ V or $V_I > V_{CC} + 0.5$ V	-	± 50	mA
I_{SW}	switch current	$V_{SW} = 0$ V to V_{CC}	-	± 128	mA
I_{CC}	supply current		-	+50	mA
I_{GND}	ground current		-50	-	mA
T_{stg}	storage temperature		-65	+150	°C
P_{tot}	total power dissipation	$T_{amb} = -40$ °C to +125 °C	[2] -	250	mW

[1] The minimum input and output voltage ratings may be exceeded if the input and output current ratings are observed.

[2] For TSSOP5 and SC-74A packages: above 87.5 °C the value of P_{tot} derates linearly with 4.0 mW/K.
For XSON6 packages: above 118 °C the value of P_{tot} derates linearly with 7.8 mW/K.

9. Recommended operating conditions

Table 6. Recommended operating conditions

Symbol	Parameter	Conditions	Min	Typ	Max	Unit
V_{CC}	supply voltage		2.3	-	3.6	V
V_I	input voltage		0	-	3.6	V
V_{SW}	switch voltage	enable and disable mode	0	-	V_{CC}	V
T_{amb}	ambient temperature		-40	-	+125	°C
$\Delta t/\Delta V$	input transition rise and fall rate	$V_{CC} = 2.3$ V to 3.6 V	[1] 0	-	20	ns/V

[1] Applies to control signal levels.

10. Static characteristics

Table 7. Static characteristics

At recommended operating conditions; voltages are referenced to GND (ground = 0 V).

Symbol	Parameter	Conditions	Min	Typ ^[1]	Max	Unit
$T_{amb} = -40$ °C to +85 °C						
V_{IH}	HIGH-level input voltage	$V_{CC} = 2.3$ V to 2.7 V	1.7	-	-	V
		$V_{CC} = 2.7$ V to 3.6 V	2.0	-	-	V
V_{IL}	LOW-level input voltage	$V_{CC} = 2.3$ V to 2.7 V	-	-	0.7	V
		$V_{CC} = 2.7$ V to 3.6 V	-	-	0.8	V
I_I	input leakage current	$V_I = GND$ to V_{CC} ; $V_{CC} = 3.6$ V	-	-	± 1.0	μ A
$I_{S(OFF)}$	OFF-state leakage current	$V_I = V_{IH}$ or V_{IL} ; $V_O = V_{CC} - GND$; $V_{CC} = 3.6$ V; see Figure 6	-	± 0.1	± 5	μ A
$I_{S(ON)}$	ON-state leakage current	$V_I = V_{IH}$ or V_{IL} ; $V_{CC} = 3.6$ V; see Figure 7	-	± 0.1	± 5	μ A

Table 7. Static characteristics ...continued

At recommended operating conditions; voltages are referenced to GND (ground = 0 V).

Symbol	Parameter	Conditions	Min	Typ ^[1]	Max	Unit
I _{OFF}	power-off leakage current	V _I or V _O = 0 V to 3.6 V; V _{CC} = 0 V	-	-	±10	μA
I _{CC}	supply current	V _I = GND or V _{CC} ; I _O = 0 A; V _{CC} = 3.6 V	-	-	10	μA
ΔI _{CC}	additional supply current	control input; V _I = V _{CC} - 0.6 V; V _{CC} = 3.6 V	[2] -	-	300	μA
C _I	input capacitance	control input; V _I = 0 V or 3 V	-	2.5	-	pF
C _{sw}	switch capacitance	OFF-state	-	7.0	-	pF
		ON-state	-	10.3	-	pF

T_{amb} = -40 °C to +125 °C

V _{IH}	HIGH-level input voltage	V _{CC} = 2.3 V to 2.7 V	1.7	-	-	V
		V _{CC} = 2.7 V to 3.6 V	2.0	-	-	V
V _{IL}	LOW-level input voltage	V _{CC} = 2.3 V to 2.7 V	-	-	0.7	V
		V _{CC} = 2.7 V to 3.6 V	-	-	0.8	V
I _I	input leakage current	V _I = GND to V _{CC} ; V _{CC} = 3.6 V	-	-	±100	μA
I _{S(OFF)}	OFF-state leakage current	V _I = V _{IH} or V _{IL} ; V _O = V _{CC} - GND; V _{CC} = 3.6 V; see Figure 6	-	-	±200	μA
I _{S(ON)}	ON-state leakage current	V _I = V _{IH} or V _{IL} ; V _{CC} = 3.6 V; see Figure 7	-	-	±200	μA
I _{OFF}	power-off leakage current	V _I or V _O = 0 V to 3.6 V; V _{CC} = 0 V	-	-	±10	μA
I _{CC}	supply current	V _I = GND or V _{CC} ; I _O = 0 A; V _{CC} = 3.6 V	-	-	200	μA
ΔI _{CC}	additional supply current	control input; V _I = V _{CC} - 0.6 V; V _{CC} = 3.6 V	[2] -	-	5000	μA

[1] Typical values are measured at T_{amb} = 25 °C and at V_{CC} = 3.3 V.

[2] One input at 3 V, other inputs at V_{CC} or GND.

Table 8. Resistance R_{ON}

At recommended operating conditions; voltages are referenced to GND (ground = 0 V); see test circuit [Figure 8](#).

Symbol	Parameter	Conditions	-40 °C to +85 °C			-40 °C to +125 °C		Unit
			Min	Typ ^[1]	Max	Min	Max	
R _{ON}	ON resistance	V _{CC} = 2.3 V; see Figure 9	[2]					
		I _{SW} = 64 mA; V _I = 0 V	-	4.7	10	-	15.0	Ω
		I _{SW} = 24 mA; V _I = 0 V	-	4.5	10	-	15.0	Ω
		I _{SW} = 15 mA; V _I = 1.7 V	-	11	25	-	38.0	Ω
		V _{CC} = 3.0 V; see Figure 10						
		I _{SW} = 64 mA; V _I = 0 V	-	4.2	7	-	11.0	Ω
		I _{SW} = 24 mA; V _I = 0 V	-	4.1	7	-	11.0	Ω
I _{SW} = 15 mA; V _I = 2.4 V	-	7.3	15	-	25.5	Ω		

[1] Typical values are measured at T_{amb} = 25 °C.

[2] Measured by the voltage drop between the A and B terminals at the indicated current through the switch. ON-state resistance is determined by the lower of the voltages of the two (A or B) terminals.

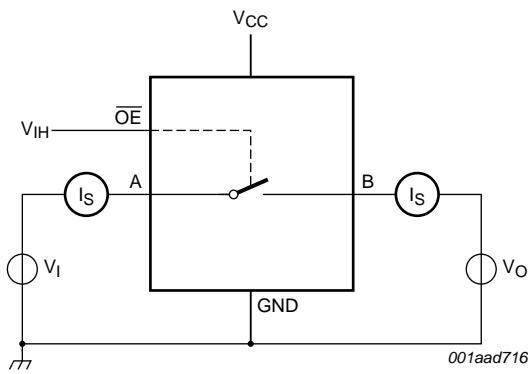

Fig 6. Test circuit for measuring OFF-state leakage current

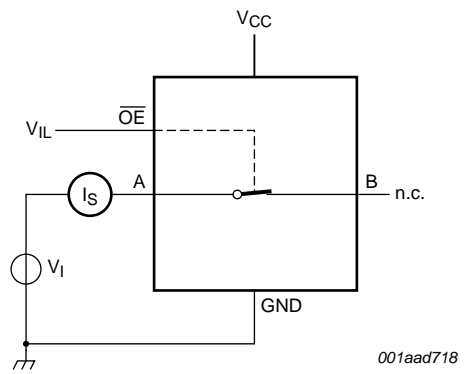
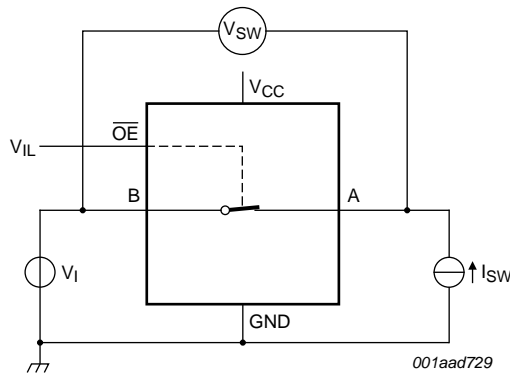
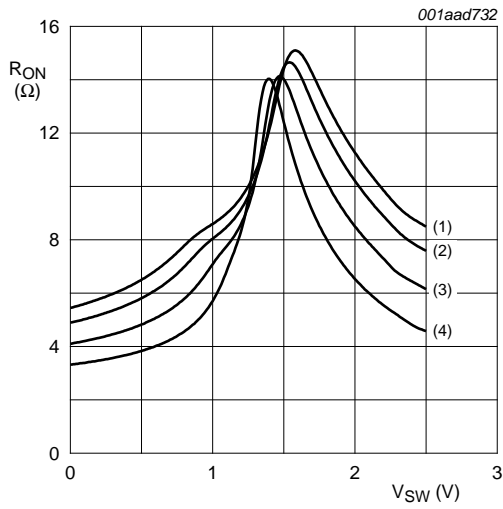

Fig 7. Test circuit for measuring ON-state leakage current



$$R_{ON} = V_{SW} / I_{SW}$$

Fig 8. Test circuit for measuring ON-resistance



- (1) $T_{amb} = 125\text{ °C}$
- (2) $T_{amb} = 85\text{ °C}$
- (3) $T_{amb} = 25\text{ °C}$
- (4) $T_{amb} = -40\text{ °C}$

a. $V_{CC} = 2.5\text{ V}; I_{SW} = 15\text{ mA}; V_{SW} = 1.7\text{ V}$

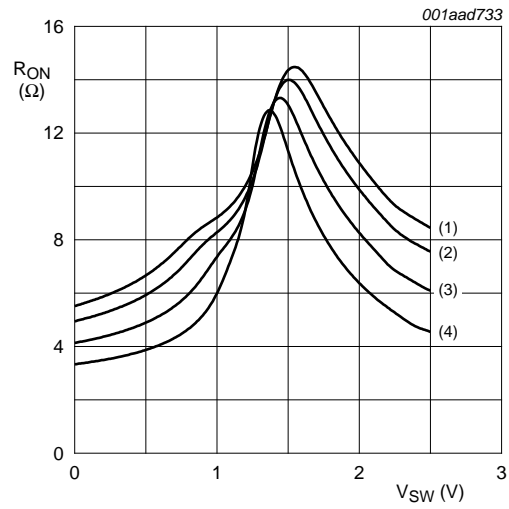

- (1) $T_{amb} = 125\text{ °C}$
- (2) $T_{amb} = 85\text{ °C}$
- (3) $T_{amb} = 25\text{ °C}$
- (4) $T_{amb} = -40\text{ °C}$

b. $V_{CC} = 2.5\text{ V}; I_{SW} = 24\text{ mA}; V_{SW} = 0\text{ V}$

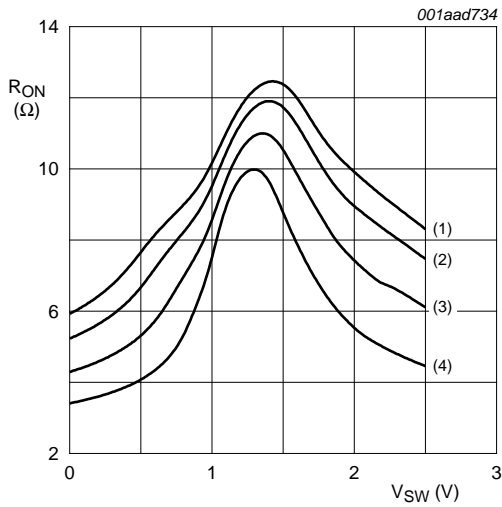

- (1) $T_{amb} = 125\text{ °C}$
- (2) $T_{amb} = 85\text{ °C}$
- (3) $T_{amb} = 25\text{ °C}$
- (4) $T_{amb} = -40\text{ °C}$

c. $V_{CC} = 2.5\text{ V}; I_{SW} = 64\text{ mA}; V_{SW} = 0\text{ V}$

Fig 9. Switch ON-resistance as a function of input voltage at $V_{CC} = 2.5\text{ V}$

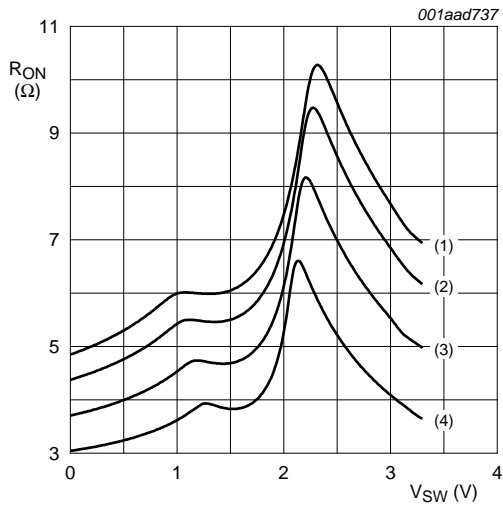

- (1) $T_{amb} = 125\text{ }^{\circ}\text{C}$
 - (2) $T_{amb} = 85\text{ }^{\circ}\text{C}$
 - (3) $T_{amb} = 25\text{ }^{\circ}\text{C}$
 - (4) $T_{amb} = -40\text{ }^{\circ}\text{C}$
- a. $V_{CC} = 3.3\text{ V}; I_{SW} = 15\text{ mA}; V_{SW} = 2.4\text{ V}$

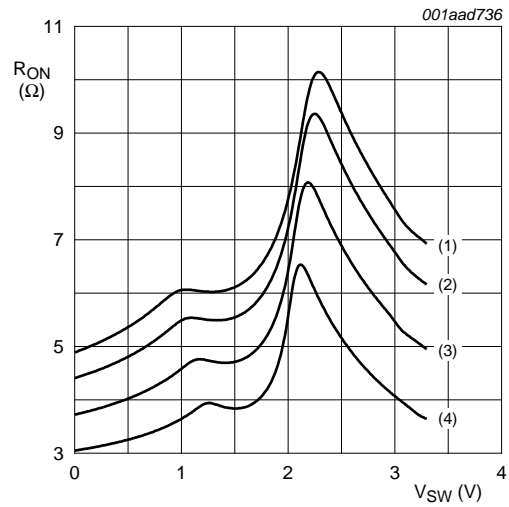

- (1) $T_{amb} = 125\text{ }^{\circ}\text{C}$
 - (2) $T_{amb} = 85\text{ }^{\circ}\text{C}$
 - (3) $T_{amb} = 25\text{ }^{\circ}\text{C}$
 - (4) $T_{amb} = -40\text{ }^{\circ}\text{C}$
- b. $V_{CC} = 3.3\text{ V}; I_{SW} = 24\text{ mA}; V_{SW} = 0\text{ V}$

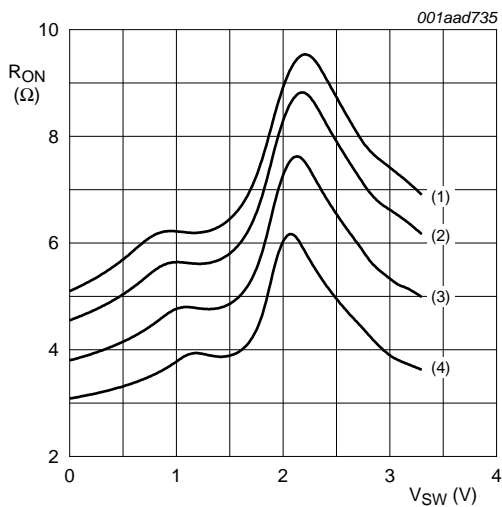

- (1) $T_{amb} = 125\text{ }^{\circ}\text{C}$
 - (2) $T_{amb} = 85\text{ }^{\circ}\text{C}$
 - (3) $T_{amb} = 25\text{ }^{\circ}\text{C}$
 - (4) $T_{amb} = -40\text{ }^{\circ}\text{C}$
- c. $V_{CC} = 3.3\text{ V}; I_{SW} = 64\text{ mA}; V_{SW} = 0\text{ V}$

Fig 10. Switch ON-resistance as a function of input voltage at $V_{CC} = 3.3\text{ V}$

11. Dynamic characteristics

Table 9. Dynamic characteristics

$GND = 0\text{ V}$; see [Figure 13](#).

Symbol	Parameter	Conditions	-40 °C to +85 °C			-40 °C to +125 °C		Unit
			Min	Typ ^[1]	Max	Min	Max	
t_{pd}	propagation delay	A to B or B to A; see Figure 11 ; $R_L = \infty\ \Omega$ [2][3]						
		$V_{CC} = 2.3\text{ V to }2.7\text{ V}$	-	-	0.21	-	0.32	ns
		$V_{CC} = 3.0\text{ V to }3.6\text{ V}$	-	0.16	0.25	-	0.39	ns
t_{en}	enable time	\overline{OE} to A or B; see Figure 12 ; $R_L = 500\ \Omega$ [4]						
		$V_{CC} = 2.3\text{ V to }2.7\text{ V}$	1.0	2.50	4.00	1.0	5.00	ns
		$V_{CC} = 3.0\text{ V to }3.6\text{ V}$	1.0	2.05	4.00	1.0	5.00	ns
t_{dis}	disable time	\overline{OE} to A or B; see Figure 12 ; $R_L = 500\ \Omega$ [5]						
		$V_{CC} = 2.3\text{ V to }2.7\text{ V}$	1.0	2.80	5.00	1.0	6.30	ns
		$V_{CC} = 3.0\text{ V to }3.6\text{ V}$	1.0	3.40	4.10	1.0	5.40	ns

- [1] All typical values are measured at $T_{amb} = 25\text{ °C}$ and at nominal V_{CC} .
- [2] The propagation delay is the calculated RC time constant of the maximum on-state resistance of the switch and the load capacitance, when driven by an ideal voltage source (zero output impedance).
- [3] t_{pd} is the same as t_{PLH} and t_{PHL} .
- [4] t_{en} is the same as t_{PZH} and t_{PZL} .
- [5] t_{dis} is the same as t_{PHZ} and t_{PLZ} .

12. Waveforms

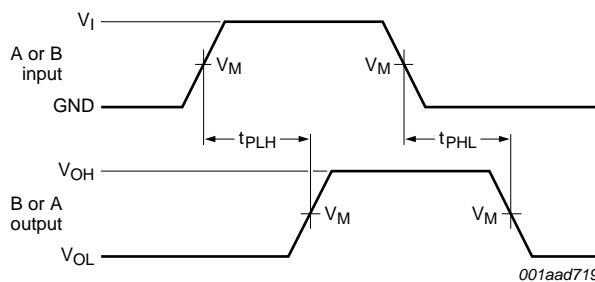

Measurement points are given in [Table 10](#).
 Logic levels: V_{OL} and V_{OH} are typical output voltage levels that occur with the output load.

Fig 11. The data input (A or B) to output (B or A) propagation delays

Table 10. Measurement points

Supply voltage	Output	Inputs		
V_{CC}	V_M	V_M	V_I	$t_r = t_f$
2.3 V to 3.6 V	$0.5 \times V_{CC}$	$0.5 \times V_{CC}$	V_{CC}	$\leq 2.0\text{ ns}$

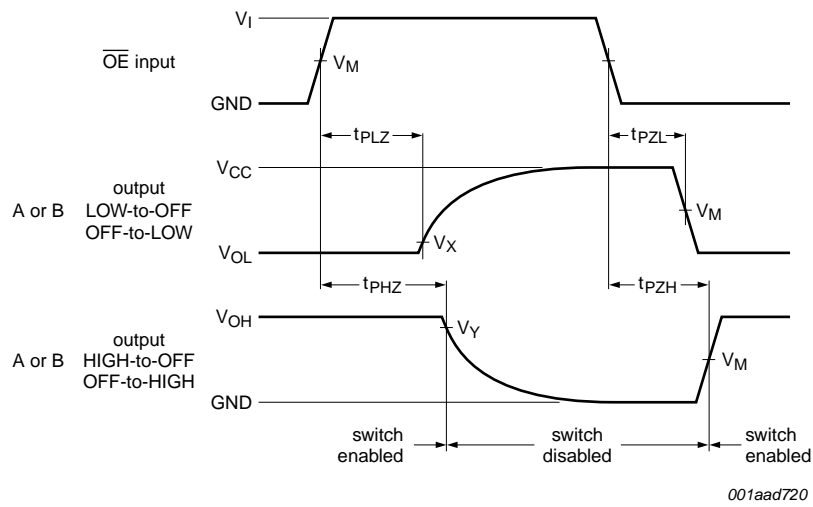

Measurement points are given in [Table 11](#).

Logic levels: V_{OL} and V_{OH} are typical output voltage levels that occur with the output load.

Fig 12. Enable and disable times

Table 11. Measurement points

Supply voltage	Input	Output		
V_{CC}	V_M	V_M	V_X	V_Y
2.3 V to 2.7 V	$0.5 \times V_{CC}$	$0.5 \times V_{CC}$	$V_{OL} + 0.15 \text{ V}$	$V_{OH} - 0.15 \text{ V}$
3.0 V to 3.6 V	$0.5 \times V_{CC}$	$0.5 \times V_{CC}$	$V_{OL} + 0.3 \text{ V}$	$V_{OH} - 0.3 \text{ V}$

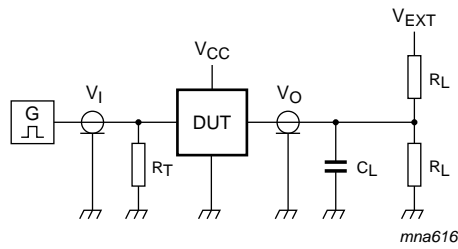

Test data is given in [Table 12](#).

Definitions for test circuit:

R_L = Load resistance.

C_L = Load capacitance including jig and probe capacitance.

R_T = Termination resistance should be equal to the output impedance Z_o of the pulse generator.

V_{EXT} = Test voltage for switching times.

Fig 13. Test circuit for measuring switching times

Table 12. Test data

Supply voltage	Load	V_{EXT}	t_{PLH} , t_{PHL}	t_{PZH} , t_{PHZ}	t_{PZL} , t_{PLZ}
V_{CC}	C_L				
2.3 V to 2.7 V	30 pF	open	open	GND	$2 \times V_{CC}$
3.0 V to 3.6 V	50 pF	open	open	GND	$2 \times V_{CC}$

13. Package outline

TSSOP5: plastic thin shrink small outline package; 5 leads; body width 1.25 mm

SOT353-1

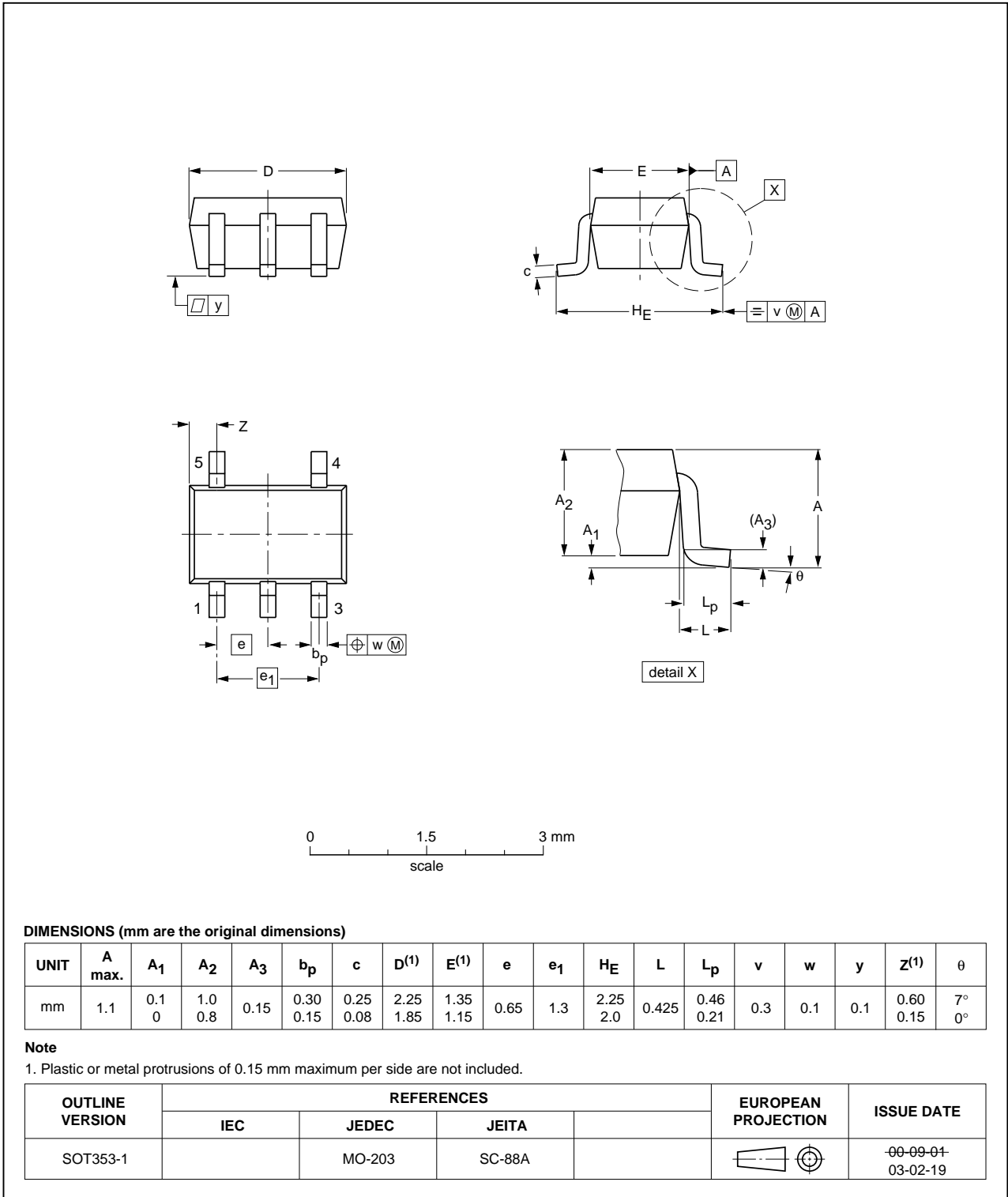

Fig 14. Package outline SOT353-1 (TSSOP5)

Plastic surface-mounted package; 5 leads

SOT753

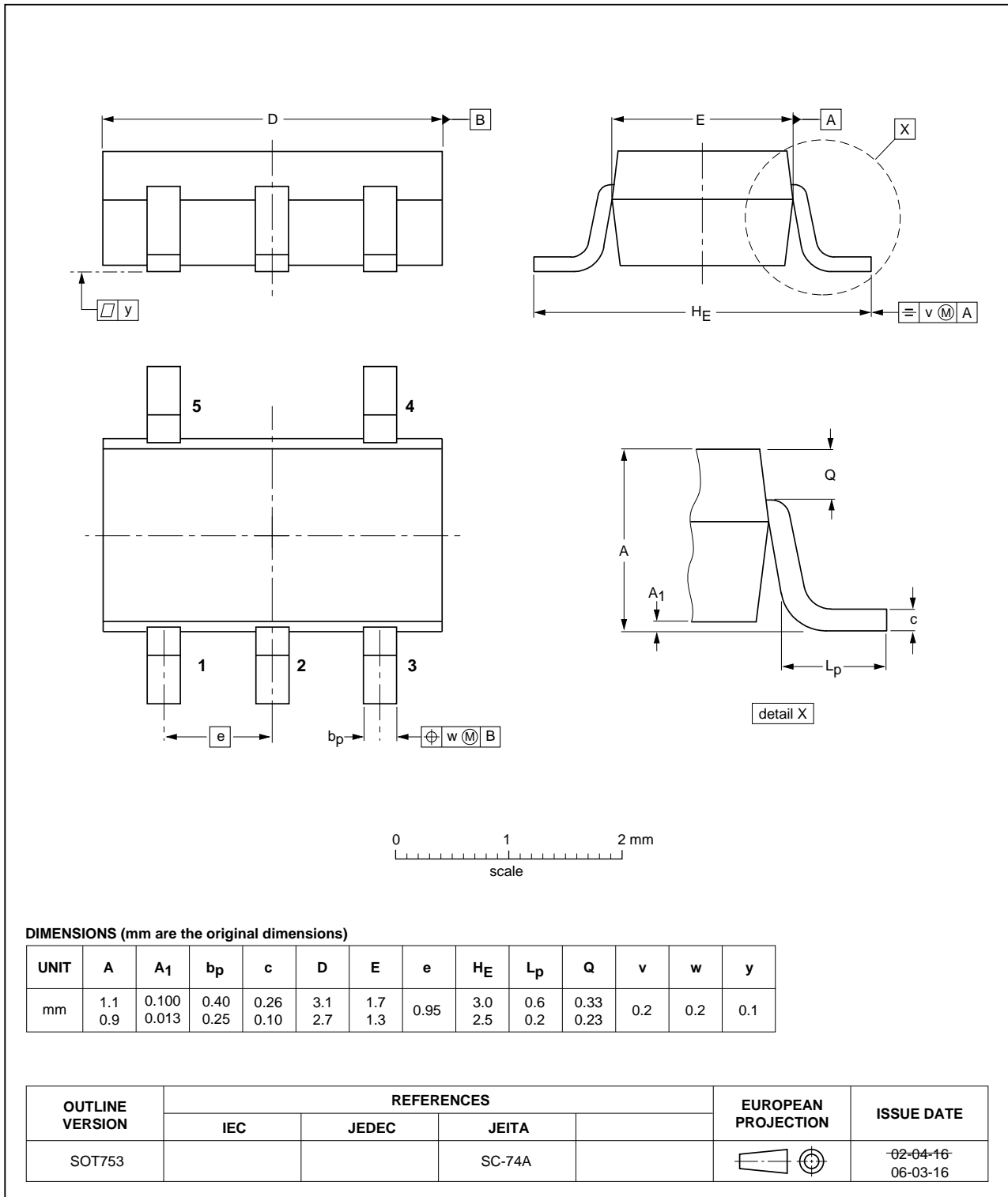

Fig 15. Package outline SOT753

XSON6: plastic extremely thin small outline package; no leads; 6 terminals; body 1 x 1.45 x 0.5 mm

SOT886

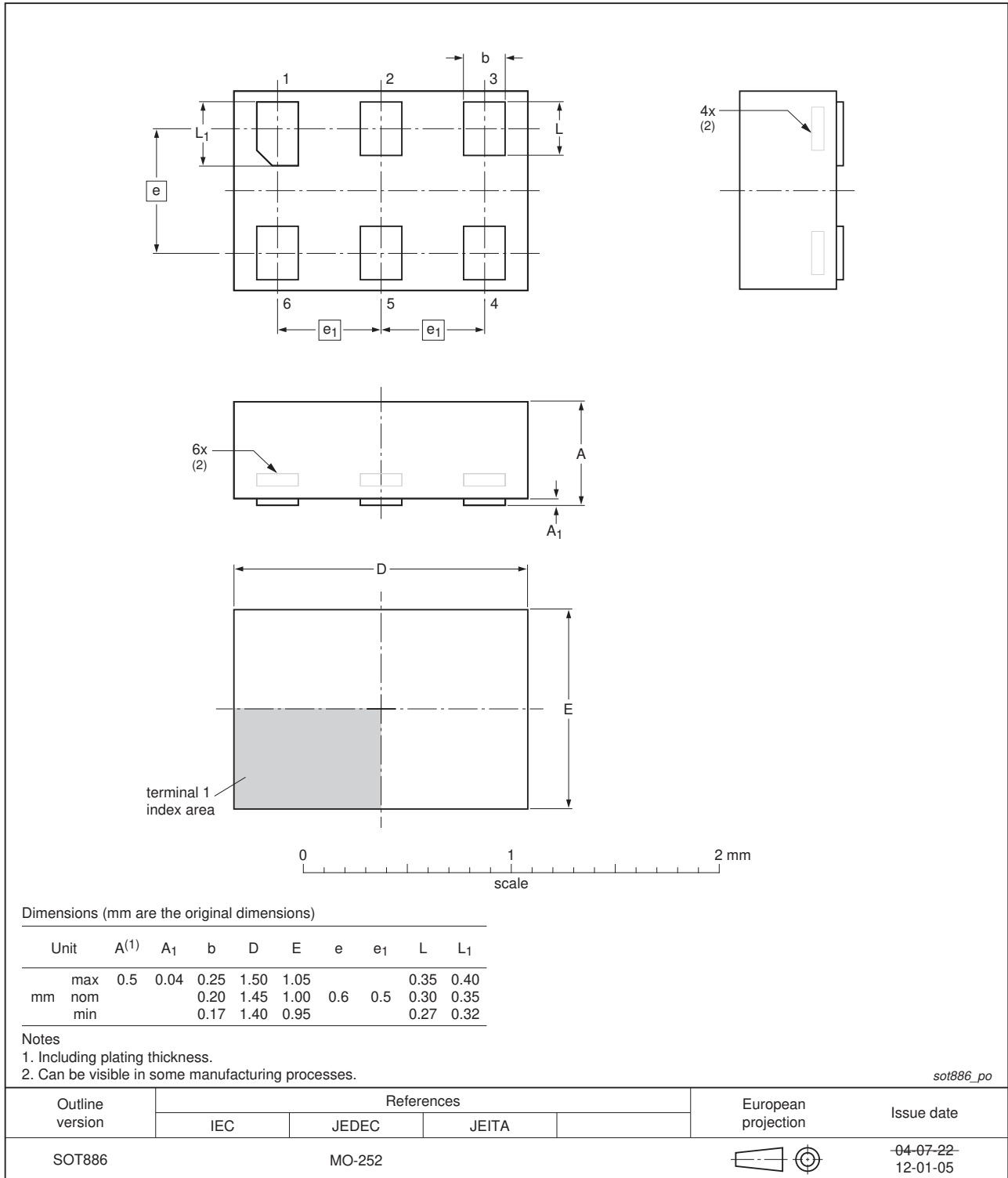

Fig 16. Package outline SOT886 (XSON6)

XSON6: plastic extremely thin small outline package; no leads; 6 terminals; body 1 x 1 x 0.5 mm

SOT891

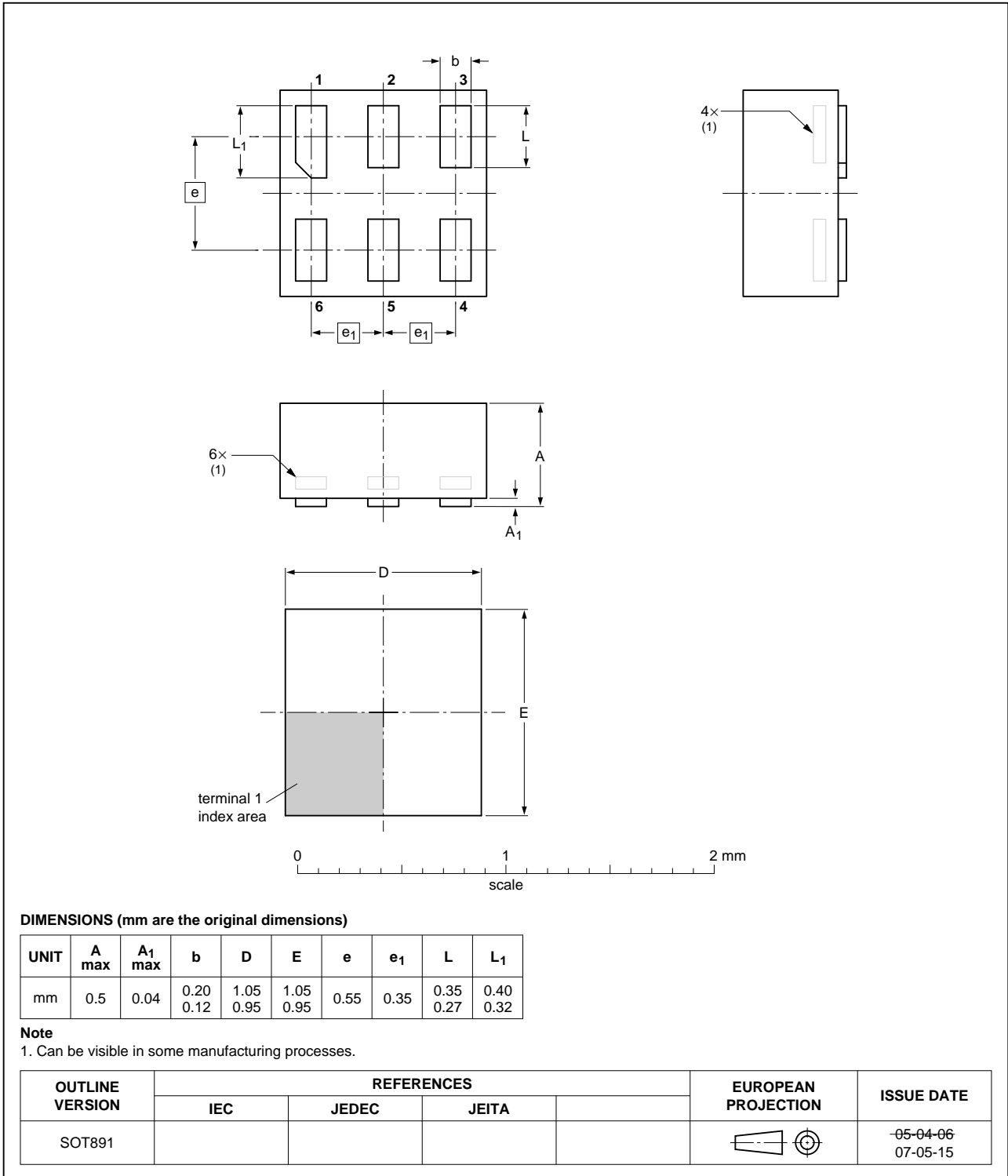

Fig 17. Package outline SOT891 (XSON6)

**XSON6: extremely thin small outline package; no leads;
6 terminals; body 0.9 x 1.0 x 0.35 mm**

SOT1115

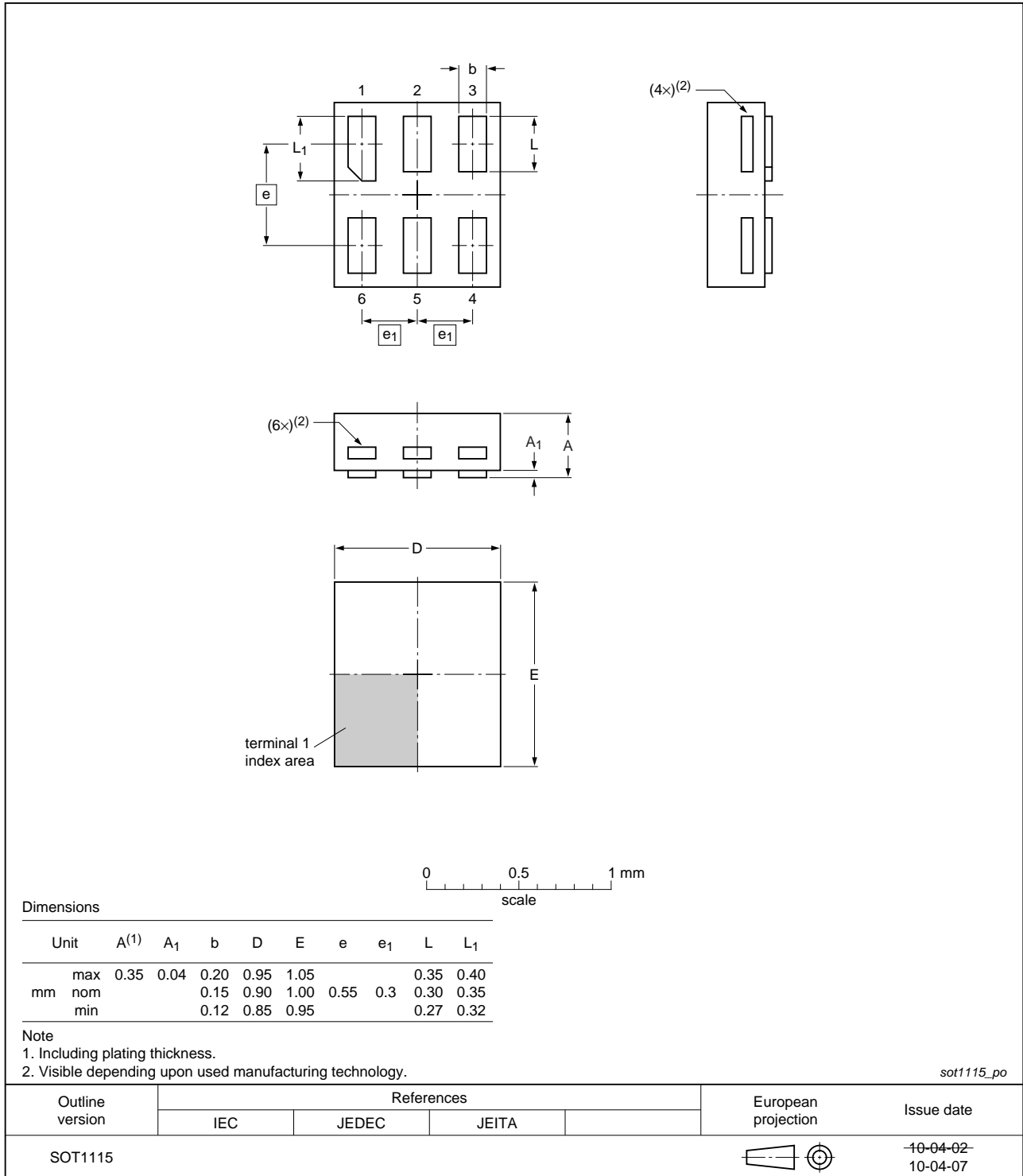

Fig 18. Package outline SOT1115 (XSON6)

**XSON6: extremely thin small outline package; no leads;
6 terminals; body 1.0 x 1.0 x 0.35 mm**

SOT1202

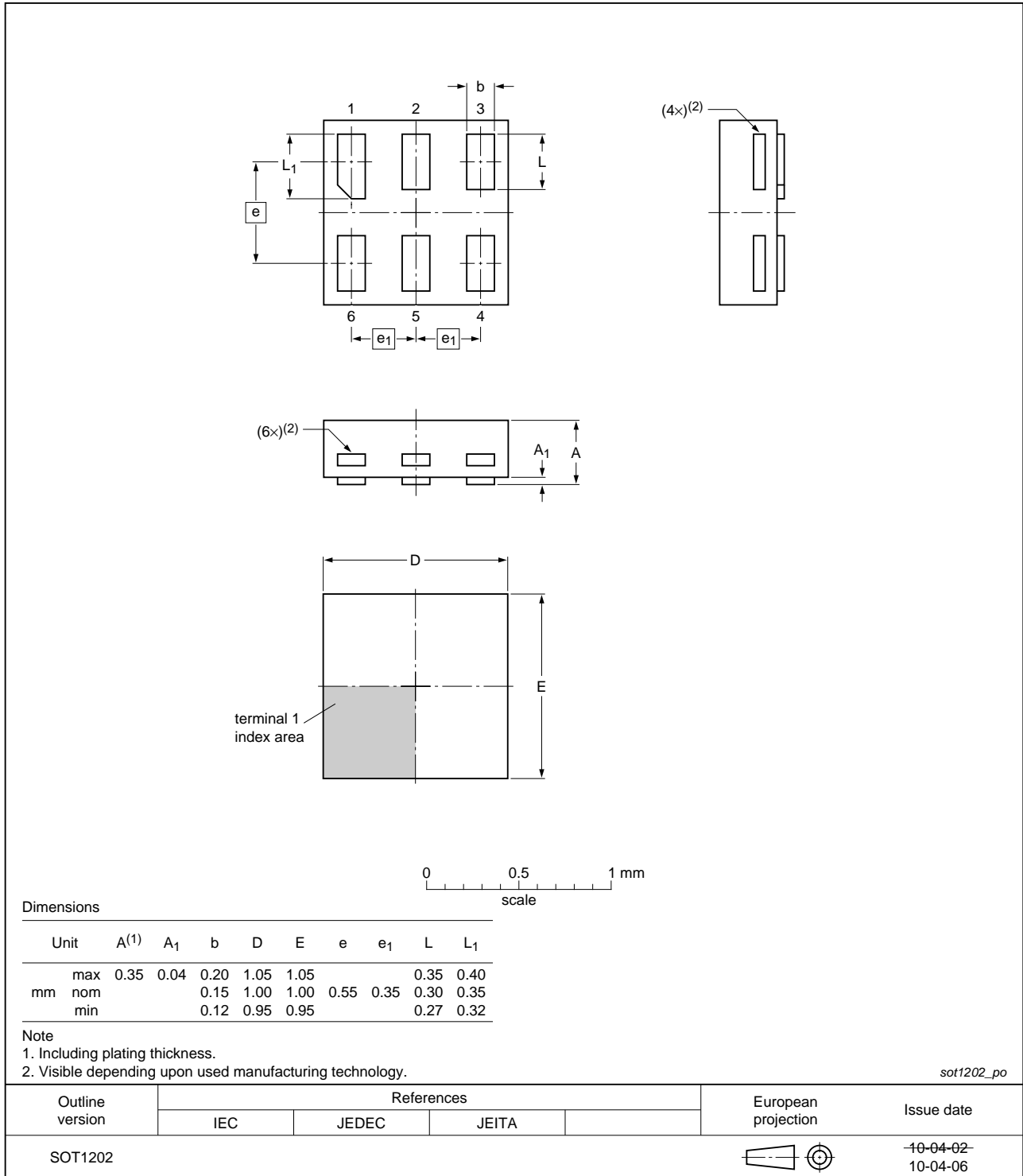

Fig 19. Package outline SOT1202 (XSON6)

14. Abbreviations

Table 13. Abbreviations

Acronym	Description
CDM	Charged Device Model
CMOS	Complementary Metal Oxide Semiconductor
DUT	Device Under Test
ESD	ElectroStatic Discharge
HBM	Human Body Model
MM	Machine Model

15. Revision history

Table 14. Revision history

Document ID	Release date	Data sheet status	Change notice	Supersedes
74CBTLV1G125 v.4	20120905	Product data sheet	-	74CBTLV1G125 v.3
Modifications:	<ul style="list-style-type: none"> Package outline drawing of SOT886 (Figure 16) modified. 			
74CBTLV1G125 v.3	20111215	Product data sheet	-	74CBTLV1G125 v.2
Modifications:	<ul style="list-style-type: none"> Legal pages updated. 			
74CBTLV1G125 v.2	20100729	Product data sheet	-	74CBTLV1G125 v.1
74CBTLV1G125 v.1	20070223	Product data sheet	-	-

16. Legal information

16.1 Data sheet status

Document status ^{[1][2]}	Product status ^[3]	Definition
Objective [short] data sheet	Development	This document contains data from the objective specification for product development.
Preliminary [short] data sheet	Qualification	This document contains data from the preliminary specification.
Product [short] data sheet	Production	This document contains the product specification.

[1] Please consult the most recently issued document before initiating or completing a design.

[2] The term 'short data sheet' is explained in section "Definitions".

[3] The product status of device(s) described in this document may have changed since this document was published and may differ in case of multiple devices. The latest product status information is available on the Internet at URL <http://www.nxp.com>.

16.2 Definitions

Draft — The document is a draft version only. The content is still under internal review and subject to formal approval, which may result in modifications or additions. NXP Semiconductors does not give any representations or warranties as to the accuracy or completeness of information included herein and shall have no liability for the consequences of use of such information.

Short data sheet — A short data sheet is an extract from a full data sheet with the same product type number(s) and title. A short data sheet is intended for quick reference only and should not be relied upon to contain detailed and full information. For detailed and full information see the relevant full data sheet, which is available on request via the local NXP Semiconductors sales office. In case of any inconsistency or conflict with the short data sheet, the full data sheet shall prevail.

Product specification — The information and data provided in a Product data sheet shall define the specification of the product as agreed between NXP Semiconductors and its customer, unless NXP Semiconductors and customer have explicitly agreed otherwise in writing. In no event however, shall an agreement be valid in which the NXP Semiconductors product is deemed to offer functions and qualities beyond those described in the Product data sheet.

16.3 Disclaimers

Limited warranty and liability — Information in this document is believed to be accurate and reliable. However, NXP Semiconductors does not give any representations or warranties, expressed or implied, as to the accuracy or completeness of such information and shall have no liability for the consequences of use of such information. NXP Semiconductors takes no responsibility for the content in this document if provided by an information source outside of NXP Semiconductors.

In no event shall NXP Semiconductors be liable for any indirect, incidental, punitive, special or consequential damages (including - without limitation - lost profits, lost savings, business interruption, costs related to the removal or replacement of any products or rework charges) whether or not such damages are based on tort (including negligence), warranty, breach of contract or any other legal theory.

Notwithstanding any damages that customer might incur for any reason whatsoever, NXP Semiconductors' aggregate and cumulative liability towards customer for the products described herein shall be limited in accordance with the *Terms and conditions of commercial sale* of NXP Semiconductors.

Right to make changes — NXP Semiconductors reserves the right to make changes to information published in this document, including without limitation specifications and product descriptions, at any time and without notice. This document supersedes and replaces all information supplied prior to the publication hereof.

Suitability for use — NXP Semiconductors products are not designed, authorized or warranted to be suitable for use in life support, life-critical or safety-critical systems or equipment, nor in applications where failure or malfunction of an NXP Semiconductors product can reasonably be expected to result in personal injury, death or severe property or environmental damage. NXP Semiconductors and its suppliers accept no liability for inclusion and/or use of NXP Semiconductors products in such equipment or applications and therefore such inclusion and/or use is at the customer's own risk.

Applications — Applications that are described herein for any of these products are for illustrative purposes only. NXP Semiconductors makes no representation or warranty that such applications will be suitable for the specified use without further testing or modification.

Customers are responsible for the design and operation of their applications and products using NXP Semiconductors products, and NXP Semiconductors accepts no liability for any assistance with applications or customer product design. It is customer's sole responsibility to determine whether the NXP Semiconductors product is suitable and fit for the customer's applications and products planned, as well as for the planned application and use of customer's third party customer(s). Customers should provide appropriate design and operating safeguards to minimize the risks associated with their applications and products.

NXP Semiconductors does not accept any liability related to any default, damage, costs or problem which is based on any weakness or default in the customer's applications or products, or the application or use by customer's third party customer(s). Customer is responsible for doing all necessary testing for the customer's applications and products using NXP Semiconductors products in order to avoid a default of the applications and the products or of the application or use by customer's third party customer(s). NXP does not accept any liability in this respect.

Limiting values — Stress above one or more limiting values (as defined in the Absolute Maximum Ratings System of IEC 60134) will cause permanent damage to the device. Limiting values are stress ratings only and (proper) operation of the device at these or any other conditions above those given in the Recommended operating conditions section (if present) or the Characteristics sections of this document is not warranted. Constant or repeated exposure to limiting values will permanently and irreversibly affect the quality and reliability of the device.

Terms and conditions of commercial sale — NXP Semiconductors products are sold subject to the general terms and conditions of commercial sale, as published at <http://www.nxp.com/profile/terms>, unless otherwise agreed in a valid written individual agreement. In case an individual agreement is concluded only the terms and conditions of the respective agreement shall apply. NXP Semiconductors hereby expressly objects to applying the customer's general terms and conditions with regard to the purchase of NXP Semiconductors products by customer.

No offer to sell or license — Nothing in this document may be interpreted or construed as an offer to sell products that is open for acceptance or the grant, conveyance or implication of any license under any copyrights, patents or other industrial or intellectual property rights.

Export control — This document as well as the item(s) described herein may be subject to export control regulations. Export might require a prior authorization from competent authorities.

Non-automotive qualified products — Unless this data sheet expressly states that this specific NXP Semiconductors product is automotive qualified, the product is not suitable for automotive use. It is neither qualified nor tested in accordance with automotive testing or application requirements. NXP Semiconductors accepts no liability for inclusion and/or use of non-automotive qualified products in automotive equipment or applications.

In the event that customer uses the product for design-in and use in automotive applications to automotive specifications and standards, customer (a) shall use the product without NXP Semiconductors' warranty of the product for such automotive applications, use and specifications, and (b) whenever customer uses the product for automotive applications beyond

NXP Semiconductors' specifications such use shall be solely at customer's own risk, and (c) customer fully indemnifies NXP Semiconductors for any liability, damages or failed product claims resulting from customer design and use of the product for automotive applications beyond NXP Semiconductors' standard warranty and NXP Semiconductors' product specifications.

Translations — A non-English (translated) version of a document is for reference only. The English version shall prevail in case of any discrepancy between the translated and English versions.

16.4 Trademarks

Notice: All referenced brands, product names, service names and trademarks are the property of their respective owners.

17. Contact information

For more information, please visit: <http://www.nxp.com>

For sales office addresses, please send an email to: salesaddresses@nxp.com

18. Contents

1	General description	1
2	Features and benefits	1
3	Ordering information	2
4	Marking	2
5	Functional diagram	2
6	Pinning information	3
6.1	Pinning	3
6.2	Pin description	3
7	Functional description	3
7.1	Function table	3
8	Limiting values	4
9	Recommended operating conditions	4
10	Static characteristics	4
11	Dynamic characteristics	9
12	Waveforms	9
13	Package outline	12
14	Abbreviations	18
15	Revision history	18
16	Legal information	19
16.1	Data sheet status	19
16.2	Definitions	19
16.3	Disclaimers	19
16.4	Trademarks	20
17	Contact information	20
18	Contents	21

Please be aware that important notices concerning this document and the product(s) described herein, have been included in section 'Legal information'.

© NXP B.V. 2012.

All rights reserved.

For more information, please visit: <http://www.nxp.com>

For sales office addresses, please send an email to: salesaddresses@nxp.com

Date of release: 5 September 2012

Document identifier: 74CBTLV1G125