

FP-LDSB

Large Flat Panel Digital Signage Mount

Product Features:

Holds most 42" – 90" flat panels in portrait or landscape

Maximum mounting hole pattern – 810mm x 530mm
(810mm x 810mm with extensions)

Adjustable tilt -5° to +15° lockable at 5° increments

Sectional wall plate can be integrated with multiple FP-LDSB's to create a video wall using DS-BP

Distance from wall to back of the flat panel – 2.5"
(2.6" w/ extensions)

Load capacity – 180 lbs

Black powder coat finish

Product Specifications: *(for Architects & Engineers)*

The wall flush with tilt mount for large digital signage flat panels shall be the Video Mount Products (VMP) FP-LDSB. The mount shall be designed to attach to at least 2 studs up to 16" apart or other suitable support surface. The mount shall be designed with a section wall plate that can have additional sections (VMP model DS-BP) added to extend the length. The mount shall be constructed primarily of formed steel. The mount shall be capable of tilting from -5° to +15° and the tilt shall be lockable at 5° increments. The adjustable mounting rails shall be capable of accommodating a maximum hole pattern of 810 mm wide and 530 mm tall without extensions and with the rail extensions included with the unit capable of reach a maximum hole pattern height of 810 mm tall. The mount shall be capable of adjusting to accommodate a wide variety of flat panels ranging in size from 42" to 90" and not necessarily be model specific. The load capacity shall be 180 lbs.

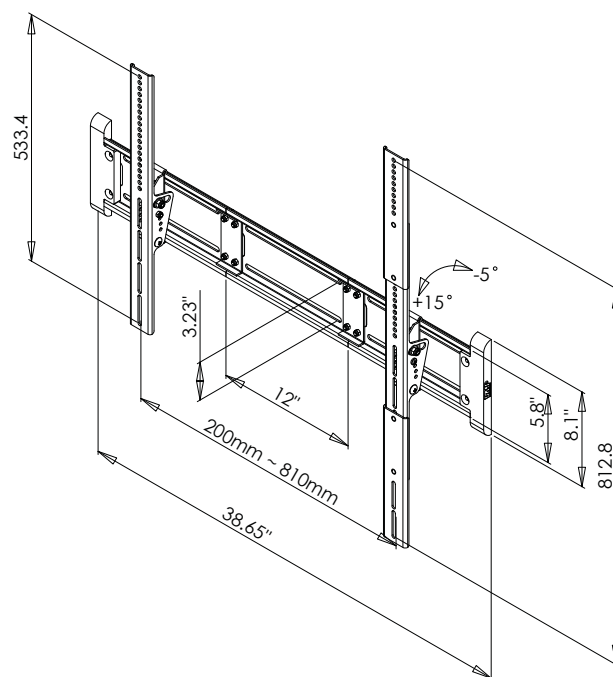

Video Mount Products

345 Log Canoe Circle Stevensville, MD 21666
Toll Free: 877.281.2169 Telephone: 410.643.6390
Facsimile: 410.643.6615 www.videomount.com

