

Demonstration System EPC9127 Quick Start Guide

*6.78 MHz, ZVS Class-D, 10 W Class 2
Wireless Power System*

Revision 1.0



DESCRIPTION

The EPC9127 wireless power demonstration system is a high efficiency, AirFuel™ Alliance compatible, Zero Voltage Switching (ZVS), Voltage Mode class-D wireless power transfer demonstration kit capable of delivering up to 10 W into a DC load while operating at 6.78 MHz (Lowest ISM band). The purpose of this demonstration system is to simplify the evaluation process of wireless power technology using eGaN® FETs.

The EPC9127 wireless power system comprises the three boards (shown in figure 1) namely:

- 1) A Source Board (Transmitter or Power Amplifier) EPC9510
- 2) A Class 2 AirFuel Alliance compliant Source Coil (Transmit Coil)
- 3) A Category 3 AirFuel Alliance compliant Receive Device EPC9513

The amplifier board features the enhancement-mode half-bridge field effect transistor (FET), the 100 V rated EPC2107 eGaN FET with integrated synchronous bootstrap FET. The amplifier is configured for single ended operation and includes the gate driver(s), oscillator, and feedback controller for the pre-regulator that ensures operation for wireless power control based on the AirFuel Alliance standard. This allows for testing compliant to the AirFuel class 2 standard over the entire load range of $\pm 35j \Omega$. The pre-regulator features the 100 V rated 65 m Ω EPC2036 as the main switching device for a SEPIC converter.

The amplifier is equipped with a pre-regulator controller that adjusts the voltage supplied to the ZVS class D amplifier based on the limits of 3 parameters; coil current, DC power delivered and maximum voltage. The coil current has the lowest priority followed by the power delivered with the amplifier supply voltage having the highest priority. Changes in the device load power demand, physical placement of the device on the source coil and other factors such as metal objects in proximity to the source coil all contribute to variations in coil current, DC power and amplifier voltage requirements. Under any conditions, the controller will ensure the correct operating conditions for the ZVS class D amplifier based on the AirFuel Alliance standard.

The pre-regulator can be bypassed to allow testing with custom control hardware. The board further allows easy access to critical measurement nodes that allow accurate power measurement instrumentation hookup. A simplified diagram of the amplifier board is given in figure 2.

The Source and Device Coils are AirFuel Alliance compliant and have been pre-tuned to operate at 6.78 MHz with the EPC9510 amplifier. The source coil is Class 2 and the device coil is Category 3 compliant.

The EPC9513 device board includes a high frequency schottky diode based full bridge rectifier, DC smoothing capacitor and 5 V regulator. The regulator is based on a SEPIC converter that features a 200 V EPC2019 eGaN FET. The power circuit is attached to the back side of the coil which is provided with a ferrite shield that prevents the circuit from shunting the coil's magnetic field.

For more information on the EPC2107, EPC2036, and EPC2019 eGaN FETs and ICs please refer to the datasheets available from EPC at www.epc-co.com. The datasheets should be read in conjunction with this quick start guide.

MECHANICAL ASSEMBLY

The assembly of the EPC9127 Wireless Demonstration kit is simple and shown in figure 1. The source coil and amplifier have been equipped with SMA connectors. The source coil is simply connected to the amplifier. The device board does not need to be mechanically attached to the source coil.

DETAILED DESCRIPTION

The Amplifier Board (EPC9510)

Figure 2 shows the system block diagram of the EPC9510 ZVS class-D amplifier with pre-regulator and figure 3 shows the details of the ZVS class-D amplifier section. The pre-regulator is used to control the ZVS class-D wireless power amplifier based on three feedback parameters 1) the magnitude of the coil current indicated by the **green LED**, 2) the DC power drawn by the amplifier indicated by the **yellow LED** and 3) a maximum supply voltage to the amplifier indicated by the **red LED**. Only one parameter at any time is used to control the pre-regulator with the highest priority being the maximum voltage supplied to the amplifier followed by the power delivered to the amplifier and lastly the magnitude of the coil current. The maximum amplifier supply voltage is pre-set to 66 V and the maximum power drawn by the amplifier is pre-set to 10 W. The coil current magnitude is pre-set to 580 mARMS, but can be made adjustable using P25. The pre-regulator comprises a SEPIC converter that can operate at full power from 17 V through 24 V.

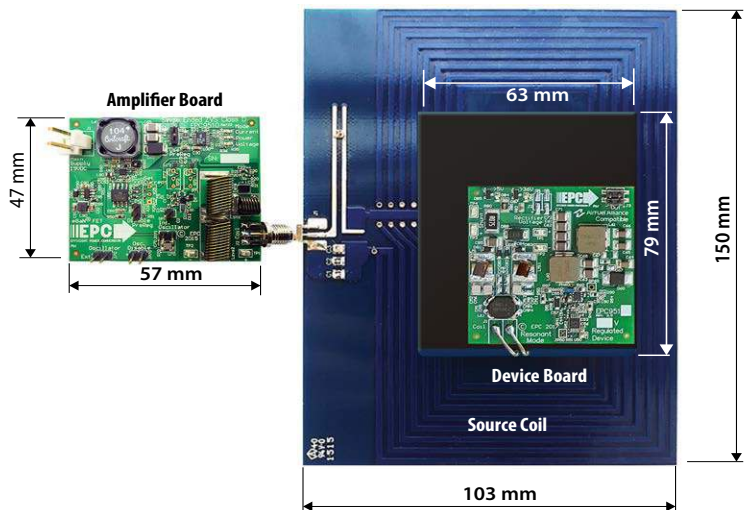

Figure 1: EPC9127 Demonstration System

Table 1: Performance Summary (T_A = 25°C) EPC9510

Symbol	Parameter	Conditions	Min	Max	Units
V _{IN}	Bus Input Voltage Range – Pre-Regulator Mode	Also used in bypass mode for logic supply	17	24	V
V _{IN}	Amp Input Voltage Range – Bypass Mode		0	80	V
V _{OUT}	Switch Node Output Voltage			66	V
I _{OUT}	Switch Node Output Current (each)			0.8*	A
V _{extosc}	External Oscillator Input Threshold	Input 'Low'	-0.3	0.8	V
		Input 'High'	2.4	5	V
V _{Pre_Disable}	Pre-regulator Disable Voltage Range	Floating	-0.3	5.5	V
I _{Pre_Disable}	Pre-regulator Disable Current	Floating	-10	10	mA
V _{Osc_Disable}	Oscillator Disable Voltage Range	Open Drain/Collector	-0.3	5	V
I _{Osc_Disable}	Oscillator Disable Current	Open Drain/Collector	-25	25	mA
V _{SgnDiff}	Differential or Single Select Voltage	Open Drain/Collector	-0.3	5.5	V
I _{SgnDiff}	Differential or Single Select Current	Open Drain/Collector	-1	1	mA

*Maximum current depends on die temperature – actual maximum current will be subject to switching frequency, bus voltage and thermals.

Table 2: Performance Summary (T_A = 25°C) Category 3 Device Board

Symbol	Parameter	Conditions	Min	Max	Units
V _{Unreg}	Un-regulated output voltage			38	V
I _{Unreg}	Un-regulated output current			1.5#	A
V _{Unreg_UV-LOR}	UVLO Enable	Un-regulated voltage rising		10.96	V
V _{Unreg_UV-LOF}	UVLO Disable	Un-regulated voltage falling	5.96		V
V _{OUT}	Output Voltage Range	V _{Unreg_min} = 8.3 V	4.8	5.1	V
I _{OUT}	Output Current Range	V _{Unreg_min} = 8.3 V	0	1#	A

Actual maximum current subject to operating temperature limits

The pre-regulator can be bypassed by connecting the positive supply directly to the ZVS class-D amplifier supply after removing the jumper at location JP1 and connecting the main positive supply to the bottom pin. JP1 can also be removed and replaced with a DC ammeter to directly measure the current drawn by the amplifier. When doing this, observe a low impedance connection to ensure continued stable operation of the controller. Together with the Kelvin voltage probes (TP1 and TP2) connected to the amplifier supply, an accurate measurement of the power drawn by the amplifier can be made.

The EPC9510 is also provided with a miniature high efficiency switch-mode 5 V supply to power the logic circuits on board such as the gate drivers and oscillator.

The amplifier comes with its own low supply current oscillator that is pre-programmed to 6.78 MHz ± 678 Hz. It can be disabled by placing a jumper into JP70 or can be externally shutdown using an externally controlled open collector / drain transistor on the terminals of JP70

(note which is the ground connection). The switch needs to be capable of sinking at least 25 mA. An external oscillator can be used instead of the internal oscillator when connected to J70 (note which is the ground connection) and the jumper (JP71) is removed.

The pre-regulator can also be disabled in a similar manner as the oscillator using JP50. However, note that this connection is floating with respect to the ground so removing the jumper for external connection requires a floating switch to correctly control this function. Refer to the datasheet of the controller IC and the schematic in this QSG for specific details.

The EPC9510 is provided with 3 LED's that indicate the mode of operation of the system. If the system is operating in coil current limit mode, then the **green LED** will illuminate. For power limit mode, the **yellow LED** will illuminate. Finally, when the pre-regulator reaches maximum output voltage the **red LED** will illuminate indicating that the system is no longer AirFuel compliant as the load impedance is too high for the amplifier to drive. When the load impedance is too high to reach power limit or voltage limit mode, then the current limit LED will illuminate incorrectly indicating current limit mode. This mode also falls outside the AirFuel standard and by measuring the amplifier supply voltage across TP1 and TP2 will show that it has nearly reached the maximum value limit.

ZVS Timing Adjustment

Setting the correct time to establish ZVS transitions is critical to achieving high efficiency with the EPC9510 amplifier. This can be done by selecting the values for R71 and R72 or P71 and P72 respectively. This procedure is best performed using a potentiometer installed at the appropriate locations that is used to determine the fixed resistor values. The timing MUST initially be set WITHOUT the source coil connected to the amplifier. The timing diagrams are given in figure 10 and should be referenced when following this procedure. Only perform these steps if changes have been made to the board as it is shipped preset. The steps are:

1. With power off, remove the jumper in JP1 and install it into JP50 to place the EPC9510 amplifier into Bypass mode. Connect the main input power supply (+) to JP1 (bottom pin – for bypass mode) with ground connected to J1 ground (-) connection.
2. With power off, connect the control input power supply bus (19V) to (+) connector J1. Note the polarity of the supply connector.
3. Connect a LOW capacitance oscilloscope probe to the probe-hole and ground post indicated in figure 9.
4. Turn on the control supply – make sure the supply is approximately 19V.
5. Turn on the main supply voltage starting at 0 V and increasing to the required predominant operating value (such as 24 V but NEVER exceed the absolute maximum voltage of 66 V).
6. While observing the oscilloscope adjust the applicable potentiometers to so achieve the green waveform of figure 10.
7. Replace the potentiometers with fixed value resistors if required. Remove the jumper from JP50 and install it back into JP1 to revert the EPC9510 back to pre-regulator mode.

Determining component values for L_{ZVS}

The ZVS tank circuit is not operated at resonance, and only provides the necessary negative device current for self-commutation of the output voltage at turn off. The capacitor C_{ZVS1} is chosen to have a very small ripple voltage component and is typically around 1 μF. The amplifier supply voltage, switch-node transition time will determine the value of inductances for L_{ZVS1} and L_{ZVS2} which needs to be sufficient to maintain ZVS operation over the DC device load resistance range and coupling between the device and source coil range and can be calculated using the following equation:

$$L_{ZVS} = \frac{\Delta t_{vt}}{8 \cdot f_{sw} \cdot (C_{OSSQ} + C_{well})} \quad (1)$$

Where:

- Δt_{vt} = Voltage transition time [s]
- f_{sw} = Operating frequency [Hz]
- C_{OSSQ} = Charge equivalent device output capacitance [F].
- C_{well} = Gate driver well capacitance [F]. Use 20 pF for the LM5113

NOTE. the amplifier supply voltage V_{AMP} is absent from the equation as it is accounted for by the voltage transition time. The C_{OSS} of the EPC2107 eGaN FETs is very low and lower than the gate driver well capacitance C_{well} which as a result must be now be included in the ZVS timing calculation. The charge equivalent capacitance can be determined using the following equation:

$$C_{OSSQ} = \frac{1}{V_{AMP}} \cdot \int_0^{V_{AMP}} C_{OSS}(v) \cdot dv \quad (2)$$

To add additional immunity margin for shifts in coil impedance, the value of L_{ZVS} can be decreased to increase the current at turn off of the devices (which will increase device losses). Typical voltage transition times range from 2 ns through 12 ns.

The Source Coil

Figure 4 shows the schematic for the source coil which is Class 2 AirFuel compliant. The matching network includes both series and shunt tuning. The matching network series tuning is differential to allow balanced connection and voltage reduction for the capacitors.

The Device Board - EPC9513

Figure 5 shows the basic schematic diagram of the EPC9513 device board which comprises a tuning circuit for the device coil with a common-mode choke for EMI suppression, a high frequency rectifier and SEPIC converter based output regulator. The EPC9513 is powered using a Category 3 AirFuel Alliance compliant device coil and by default is tuned to 6.78 MHz for the specific coil provided with it. The tuning circuit comprises both parallel and series tuning which is also differential to allow balanced connection and voltage reduction for the capacitors.

Two LEDs have been provided to indicate that the board is receiving power with an un-regulated voltage greater than 4 V (**green LED**) and the **red LED** will illuminate when the un-regulated voltage exceeds 36 V.

The EPC9513 has limited over-voltage protection using a TVS diode that clamps the un-regulated voltage to 38 V. This can occur when the receive coil is placed above a high power transmitter with insufficient distance to the transmit coil and there is little or no load connected. During an over-voltage event, the TVS diode will dissipate a large amount of power and the **red LED** will illuminate indicating an over-voltage. The receiver should removed from the transmitter as soon as possible to prevent the TVS diode from over-heating.

The EPC9513 can be operated with or without the regulator. The regulator can be disabled by inserting a jumper into position JP50 and connecting the load to the unregulated output terminals. In regulated mode, the design of the EPC9513 controller will ensure stable operation in a wireless power system. The regulator operates at 280 kHz and the controller features over current protection that limits the load current to 1 A.

The EPC9513 device boards come equipped with kelvin connections for easy and accurate measurement of the un-regulated and regulated output voltages. The rectified voltage current can also be measured using the included shunt resistor. In addition, the EPC9513 has been provided with a switch-node measurement connection for low inductance connection to an oscilloscope probe that yields reliable waveforms.

The EPC9513 is designed to operate in conjunction with EPC9127 (10 W EPC9510), EPC9128 (16 W EPC9509), EPC9120 (33 W EPC9512) and EPC9121 (10 W EPC9511) transmitter units.

QUICK START PROCEDURE

The EPC9127 demonstration system is easy to set up and evaluate the performance of the eGaN FET in a wireless power transfer application. Refer to figure 1 to assemble the system and figures 6 through 8 for proper connection and measurement setup before following the testing procedures.

The EPC9510 can be operated using any one of two alternative methods:

- a. Using the pre-regulator.
- b. By-passing the pre-regulator.

a. Operation using the pre-regulator

The pre-regulator is used to supply power to the amplifier in this mode and will limit the coil current, power delivered or maximum supply voltage to the amplifier based on the pre-determined settings.

The main 19 V supply must be capable of delivering 2 A_{DC}. DO NOT turn up the voltage of this supply when instructed to power up the board, instead simply turn on the supply. The EPC9510 board includes a pre-regulator to ensure proper operation of the board including start up.

1. Make sure the entire system is fully assembled prior to making electrical connections and make sure jumper JP1 is installed. Also make sure the source coil and device coil with load are connected.
2. With power off, connect the main input power supply bus to J1 as shown in figure 6. Note the polarity of the supply connector.
3. Make sure all instrumentation is connected to the system.
4. Turn on the main supply voltage to the required value (19 V).
5. Once operation has been confirmed, observe the output voltage, efficiency and other parameters on both the amplifier and device boards.
6. For shutdown, please follow steps in the reverse order.

b. Operation bypassing the pre-regulator

In this mode, the pre-regulator is bypassed and the main power is connected directly to the amplifier. This allows the amplifier to be operated using an external regulator. In this mode there is no protection for ensuring the correct operating conditions for the eGaN FETs.

1. Make sure the entire system is fully assembled prior to making electrical connections and make sure jumper JP1 has been removed and installed in JP50 to disable the pre-regulator and place the EPC9510 in bypass mode. Also make sure the source coil and device coil with load are connected.
2. With power off, connect the main input power supply bus to the bottom pin of JP1 and the ground to the ground connection of J1 as shown in figure 6.
3. With power off, connect the control input power supply bus to J1. Note the polarity of the supply connector. This is used to power the gate drivers and logic circuits.
4. Make sure all instrumentation is connected to the system.
5. Turn on the control supply – make sure the supply is 19 V range.
6. Turn on the main supply voltage to the required value (it is recommended to start at 0 V and do not exceed the absolute maximum voltage of 80 V).
7. Once operation has been confirmed, adjust the main supply voltage within the operating range and observe the output voltage, efficiency and other parameters on both the amplifier and device boards.
8. For shutdown, please follow steps in the reverse order. Start by reducing the main supply voltage to 0 V followed by steps 6 through 2.

NOTE.

1. When measuring the high frequency content switch-node (Source Coil Voltage), care must be taken to avoid long ground leads. An oscilloscope probe connection (preferred method) has been built into the board to simplify the measurement of the Source Coil voltage (shown in figure 9).
2. AVOID using a Lab Benchtop programmable DC as the load for the category 3 device when connected to the unregulated output. These loads have low control bandwidth and will cause the EPC9127 system to oscillate at a low frequency and may lead to failure. It is recommended to use a fixed low inductance resistor as an initial load.

THERMAL CONSIDERATIONS

The EPC9127 demonstration system showcases the EPC2107, EPC2037 and EPC2019 eGaN FETs and ICs in a wireless energy transfer application. Although the electrical performance surpasses that of traditional silicon devices, their relatively smaller size does magnify the thermal management requirements. The operator must observe the temperature of the gate driver and eGaN FETs to ensure that both are operating within the thermal limits as per the datasheets.

NOTE. The EPC9127 demonstration system has limited current protection only when operating off the Pre-Regulator. When bypassing the pre-regulator there is no current protection on board and care must be exercised not to over-current or over-temperature the devices. Excessively wide coil coupling and load range variations can lead to increased losses in the devices.

Pre-Cautions

The EPC9127 demonstration system has no enhanced protection systems and therefore should be operated with caution. Some specific precautions are:

1. Never operate the EPC9127 system with a device board that is AirFuel Alliance **compliant** as this system does not communicate with the device to correctly setup the required operating conditions and doing so can lead to failure of the device board. Contact EPC should operating the system with an AirFuel compliant device is required to obtain instructions on how to do this. Please contact EPC at info@epc-co.com should the tuning of the coil be required to change to suit specific conditions so that it can be correctly adjusted for use with the ZVS class-D amplifier.
2. There is no heat-sink on the devices and during experimental evaluation it is possible present conditions to the amplifier that may cause the devices to overheat. Always check operating conditions and monitor the temperature of the EPC devices using an IR camera.
3. Never connect the EPC9510 amplifier board into your VNA in an attempt to measure the output impedance of the amplifier. Doing so will severely damage the VNA.

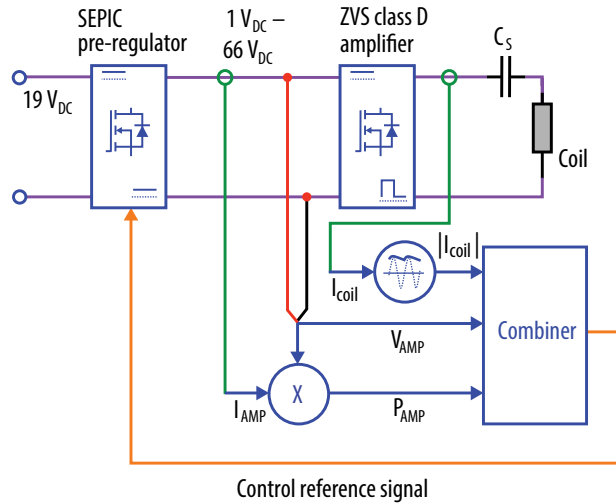

Figure 2: Block diagram of the EPC9510 wireless power amplifier

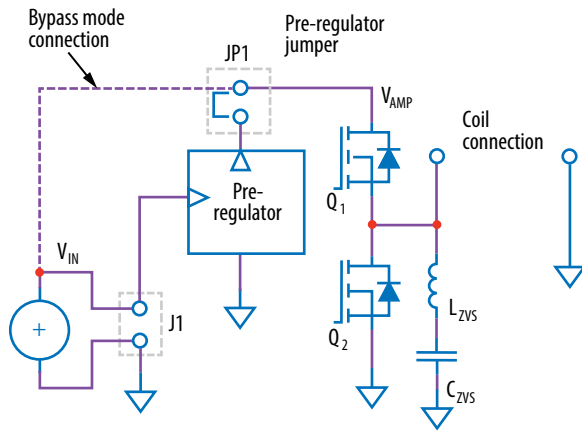

Figure 3: Diagram of EPC9510 amplifier circuit

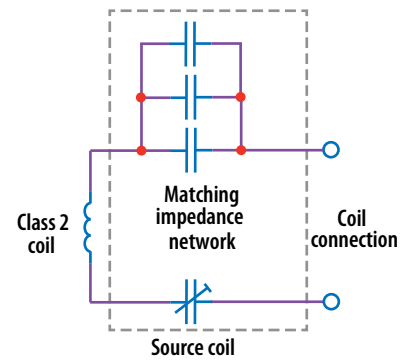

Figure 4: Basic schematic of the AirFuel Alliance Class 2 source coil

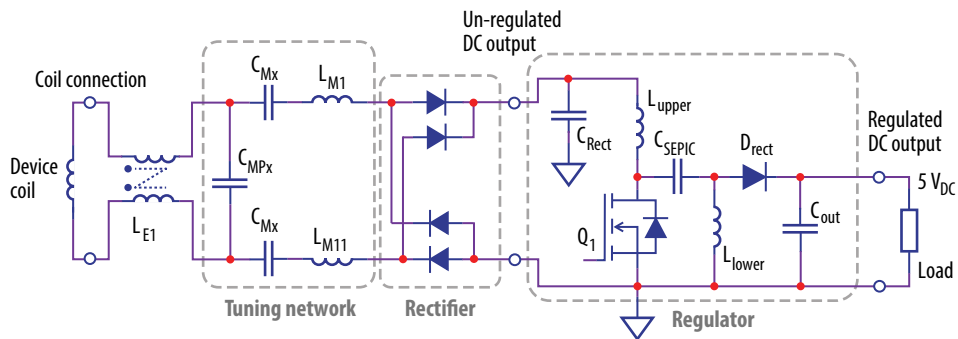

Figure 5: Schematic diagram of the EPC9513, AirFuel Alliance Category 3 device board

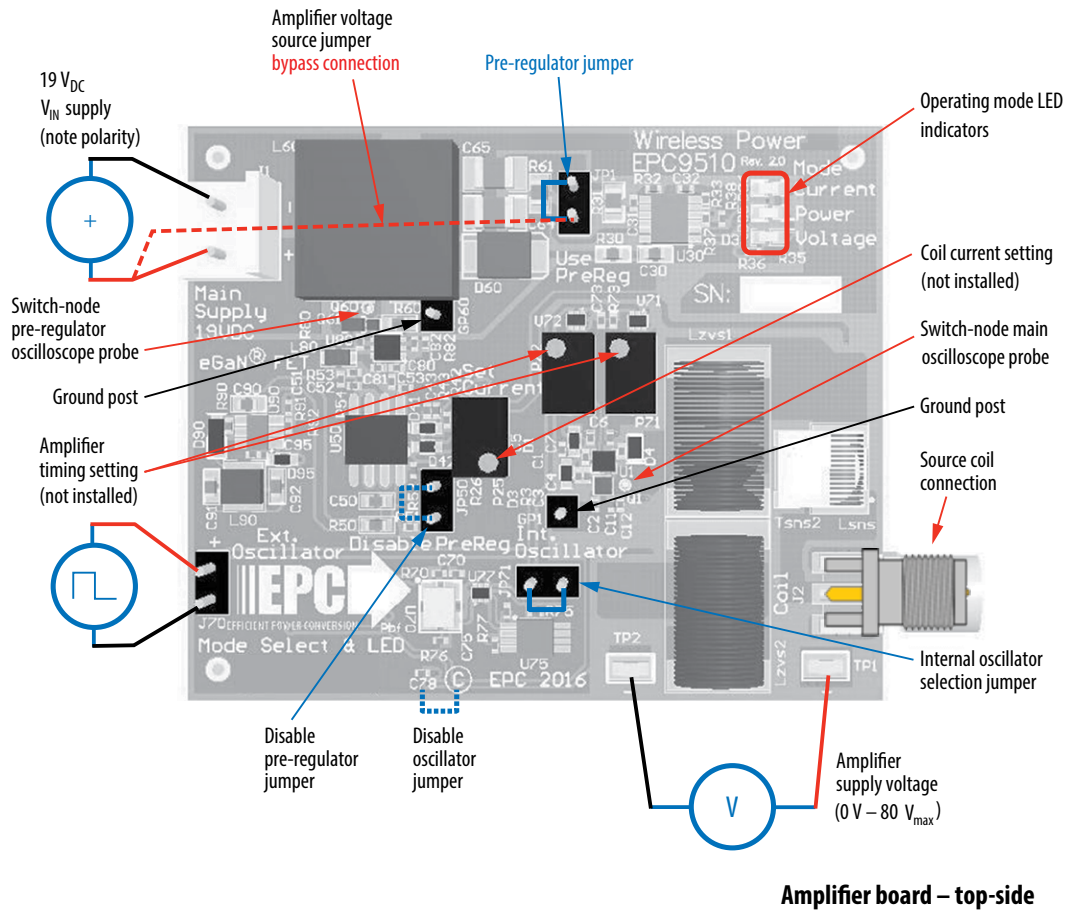

Figure 6: Proper connection and measurement setup for the amplifier board

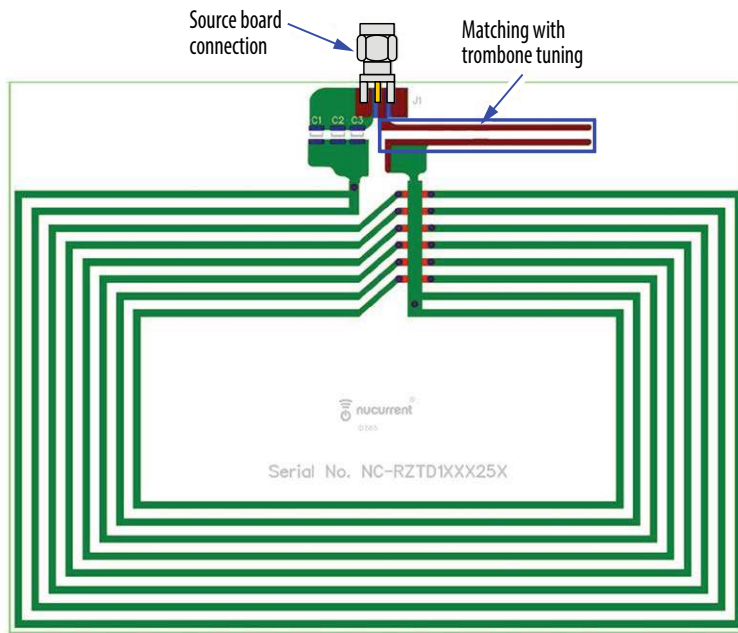

Figure 7: Proper connection for the source coil

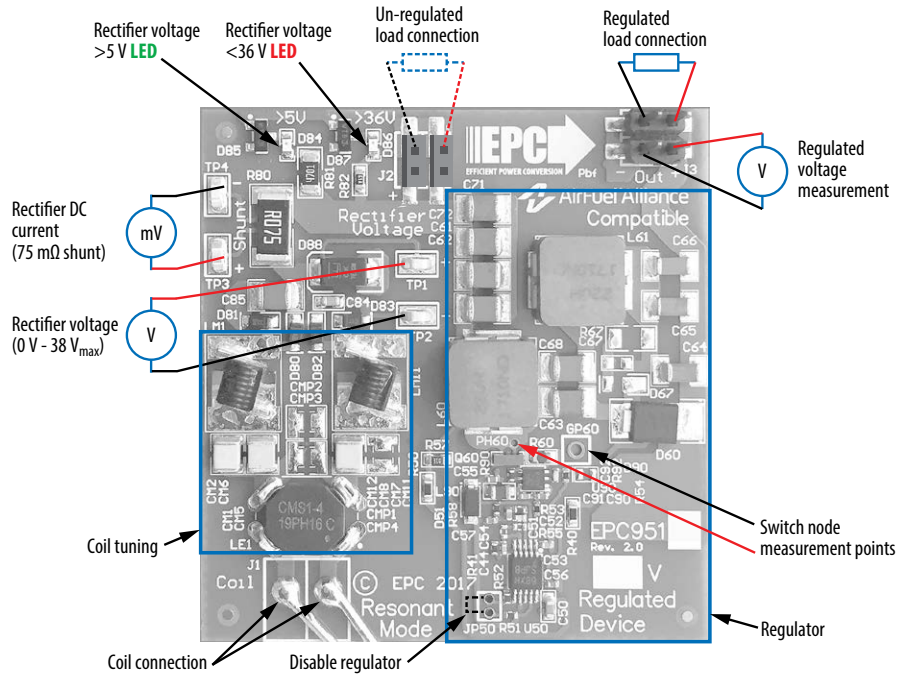

Figure 8: Proper connection and measurement setup for the receiver board

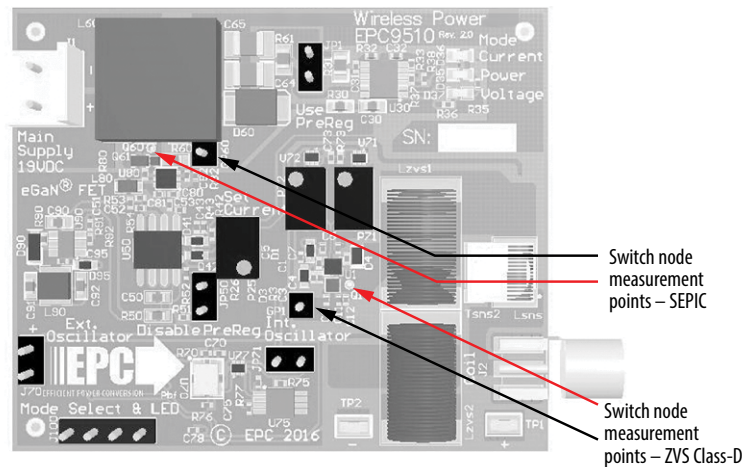

Figure 9: Proper measurement of the switch nodes using the hole and ground post

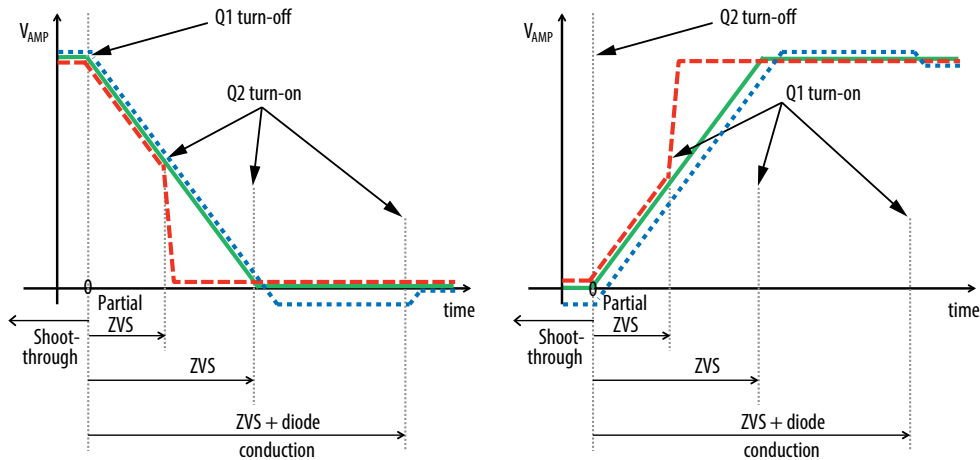

Figure 10: ZVS timing diagrams

Bill of Materials - EPC9127 Kit Includes: EPC9510 Amplifier Board, Class 2 Source Coil, EPC9513 Category 3 Receive Device.

Table 3: Bill of Materials - EPC9510 Amplifier Board

Item	Qty	Reference	Part Description	Manufacturer	Part #
1	2	C1, C80	1 μ F, 10 V	Würth	885012105012
2	14	C2, C4, C5, C51, C70, C71, C72, C77, C78, C81, C101, C130, C200, C210	100 nF, 25 V	Würth	885012105018
3	3	C3, C95, C220	22 nF, 25 V, 22 nF, 25 V, 100 nF, 16 V	Würth	885012205037
4	5	C6, C7, C31, C44, C82	22 pF, 50 V	Würth	885012005057
5	2	C11, C12	10 nF, 100 V	TDK	C1005X7S2A103K050BB
6	3	C15, C64, C65	2.2 μ F 100 V	Taiyo Yuden	HMK325B7225KN-T
7	9	C20, C27, C46, C75, C100, C135, R27, R75, R100	DNP	N/A	
8	6	C21, C45, C73, C133, C223, R45	DNP	N/A	
9	2	C22, C131	1 nF, 50 V	Würth	885012205061
10	2	C30, C50	100 nF, 100 V	Murata	GRM188R72A104KA35D
11	1	C32	47 nF, 25 V	Würth	885012205054
12	2	C43, C53	10 nF, 50 V	Würth	885012205067
13	1	C52	100 pF	Würth	885012005061
14	2	C61, C62	4.7 μ F, 50 V	Würth	885012209048
15	1	C63	10 μ F, 35 V	Taiyo Yuden	GMK325BJ106KN-T
16	3	C90, C91, C92	1 μ F, 25 V	Murata	GRM188R61E105KA12D
17	1	C221	1 nF, 50 V	Murata	GRM1555C1H102JA01D
18	1	Czvs1	1 μ F, 50 V	Würth	885012207103
19	2	D1, D95	40 V, 300 mA	ST	BAT54KFILM
20	10	D2, D3, D21, D40, D41, D42, D47, D49, D71, D72	40 V, 30 mA	Diodes Inc.	SDM03U40-7
21	1	D4	5 V1, 150 mW	Bournes	CD0603-Z5V1
22	1	D20	25 V, 11 A	Littelfuse	SMAJ22A
23	1	D35	LED 0603 Yellow	Würth	150060YS75000
24	1	D36	LED 0603 Green	Würth	150060VS75000
25	1	D37	LED 0603 Red	Würth	150060RS75000
26	1	D48	DNP	N/A	N/A
27	1	D60	100 V, 1A	On-Semi	MBRS1100T3G
28	1	D90	40 V, 1A	Diodes Inc.	PD3S140-7
29	2	D100, D101	DNP	N/A	N/A
30	2	D203, D221	3 V9, 150 mW	Bournes	CD0603-Z3V9
31	2	GP1, GP60	.1" Male Vert.	Würth	61300111121
32	1	J1	.156" Male Vert.	Molex	26614020
33	1	J2	SMA Board Edge	Linx	CONSUMA003.062
34	4	J70, JP1, JP50, JP71	.1" Male Vert.	Würth	61300211121
35	1	J100	DNP	N/A	N/A
36	2	JP10, JP72	Jumper 100	Würth	60900213421
37	1	L60	100 μ H, 2.2 A	CoilCraft	MSD1260-104ML
38	1	L80	10 μ H, 150 mA	Würth	74479778310
39	1	L90	47 μ H, 250 mA	Würth	7440329470
40	1	Lsns	DNP	N/A	N/A
41	2	Lzvs1, Lzvs2	390 nH	CoilCraft	2929SQ-391JE
42	3	P25, P71, P72	DNP	N/A	N/A
43	1	Q1	100 V, 220 m Ω with SB	EPC	EPC2107
44	4	Q2, Q20, Q46, Q135	DNP	N/A	N/A
45	2	Q3, Q60	100 V, 65 m Ω	EPC	EPC2036
46	1	Q61	DNP	N/A	N/A
47	2	R2, R82	20 Ω	Panasonic	ERJ-2RKF20R0X
48	1	R3	27 k Ω , 1%	Panasonic	ERJ-2RKF2702X
49	1	R4	4.7 Ω , 1%	Stackpole	RMCF0402FT4R70
50	1	R21	51 Ω 1/2 W	Panasonic	ERJ-P06J510V
51	1	R25	4.3 k Ω , 1%	Panasonic	ERJ-2RKF4301X
52	1	R26	22 k Ω , 1%	Panasonic	ERJ-2RKF2202X
53	2	R30, R103	100 Ω	Panasonic	ERJ-3EKF1000V
54	1	R31	71.5 k Ω , 1%	Panasonic	ERJ-6ENF7152V
55	1	R32	8.2 k Ω , 1%	Panasonic	ERJ-2RKF8201X
56	1	R33	75 k Ω , 1%	Panasonic	ERJ-2RKF7502X
57	2	R35, R36	634 Ω , 1%	Panasonic	ERJ-2RKF6340X
58	1	R37	150 k Ω , 1%	Panasonic	ERJ-2RKF1503X
59	2	R38, R91	49.9 k Ω , 1%	Panasonic	ERJ-2RKF4992X
60	4	R40, R130, R202, R203	261 k Ω , 1%	Panasonic	ERJ-3EKF2613V
61	4	R41, R49, R131, R221	6.04 k Ω , 1%	Panasonic	ERJ-2RKF6041X

Table 3: Bill of Materials - EPC9510 Amplifier Board

Item	Qty	Reference	Part Description	Manufacturer	Part #
62	1	R42	36.5 kΩ, 1%	Panasonic	ERJ-2RKF3652X
63	2	R43, R48	15.4 kΩ, 1%	Panasonic	ERJ-2RKF1542X
64	2	R44, R90	100 kΩ, 1%	Panasonic	ERJ-2RKF1003X
65	3	R46, R54, R135	0 Ω	Panasonic	ERJ-2GE0R00X
66	1	R50	10 Ω	Panasonic	ERJ-3EKF10R0V
67	1	R51	124 kΩ, 1%	Panasonic	ERJ-2RKF1243X
68	1	R52	71.5 kΩ, 1%	Panasonic	ERJ-2RKF7152X
69	1	R53	1 kΩ, 1%	Panasonic	ERJ-2RKF1001X
70	1	R60	80 mΩ 0.4 W	Vishay Dale	WSLP0603R0800FEB
71	1	R61	220 mΩ 0.333 W	Susumu	RL1220S-R22-F
72	1	R70	47 kΩ, 1%	Panasonic	ERJ-2RKF4702X
73	1	R71	430 Ω	Panasonic	ERJ-2RKF4300X
74	1	R72	180 Ω	Panasonic	ERJ-2RKF1800X
75	4	R73, R76, R77, R101	10 kΩ, 1%	Panasonic	ERJ-2RKF1002X
76	1	R80	2.2 Ω, 1%	Stackpole	RMCF0402FT2R20
77	1	R92	9.53 kΩ, 1%	Panasonic	ERJ-2RKF9531X
78	2	R102, R104	DNP	N/A	N/A
79	3	R132, R200, R222	18 kΩ, 1%	Panasonic	ERJ-2RKF1802X
80	1	R133	6.81 kΩ, 1%	Panasonic	ERJ-2RKF6811X
81	1	R134	470 kΩ, 1%	Panasonic	ERJ-2RKF4703X
82	1	R201	4.53 kΩ, 1%	Panasonic	ERJ-2RKF4531X
83	1	R220	71.5 kΩ, 1%	Panasonic	ERJ-3EKF7152V
84	1	R223	6.8 kΩ, 1%	Panasonic	ERJ-2RKF6801X
85	1	R224	330 kΩ, 1%	Panasonic	ERJ-2RKF3303X
86	2	TP1, TP2	SMD Probe Loop	Keystone	5015
87	1	Tsns1	DNP	N/A	N/A
88	1	Tsns2	1:20 Current Xmr	CoilCraft	CST7030-020LB
89	1	U1	100 V eGaN Driver	National Semiconductor	LM5113TM
90	1	U30	Power & Current Monitor	Linear	LT2940IMS#PBF
91	1	U50	Boost Controller	Texas Instruments	LM3478MAX/NOPB
92	1	U70	Pgm Osc.	EPSON	SG-8002CE-PHB-6.780MHz
93	1	U71	2 In NAND	Fairchild	NC7SZ00L6X
94	1	U72	2 In AND	Fairchild	NC7SZ08L6X
95	1	U75	DNP	N/A	N/A
96	1	U77	MMX	Fairchild	NC7SZ157L6X
97	1	U78	Reconfig Logic 57	Fairchild	NC7SZ57L6X
98	1	U80	Gate Driver with LDO	Texas Instruments	UCC27611DRV
99	1	U90	1.4 MHz, 24 V, 0.5A Buck	MPS	MP2357DJ-LF
100	3	U130, U200, U220	Comparator	Texas Instruments	TLV3201AIDBVR
101	1	U210	+Edge-trig D-Flop with Clr & Rst	Fairchild	NC7SZ74L8X

Table 4: Bill of Materials - Source Coil

Item	Qty	Reference	Part Description	Manufacturer	Part #
1	1	Ctrombone	470 pF, 300 V	Vishay	VJ1111D471KXLAT
2	1	C1	3.3 pF, 1500 V	Vishay	VJ1111D3R3CXRAJ
3	1	C2	3.3 pF, 1500 V	Vishay	VJ1111D3R3CXRAJ
4	1	C3	390 pF, 630 V	Vishay	VJ1111D391KXLAT
5	1	PCB1	Class 2 Coil Former	NuCurrent	R42DMTxD1
6	1	J1	SMA PCB Edge	Linx	CONREVSMA003.031

Table 5: Bill of Materials - EPC9513 Device Board

Item	Qty	Reference	Part Description	Manufacturer	Part #
1	1	C44	Capacitor, 100 pF, 25 V, X7R	Würth	885012205038
2	1	C50	Capacitor, 100 nF, 100 V	Murata	GRM188R72A104KA35D
3	1	C51	Capacitor, 4.7 μF, 100 V	Murata	GRM155R60J475ME47D
4	1	C52	Capacitor, 100 pF	Murata	GRM1555C1H101JA01D
5	1	C53	Capacitor, 220 pF, 50 V	Murata	GRM155R71H221KA01D
6	2	C55, C90	Capacitor, 1 μF, 16 V	TDK	C1005X5R1E105M050BC
7	3	C56, C57, C91	Capacitor, 100 nF, 16 V	Würth	885012205037
8	7	C61, C62, C63, C68, C71, C72, C85	Capacitor, 10 μF, 50 V	Taiyo Yuden	UMK325BJ106MM-T
9	3	C64, C65, C66	Capacitor, 22 μF, 35 V	TDK	C3216JB1V226M160AC
10	1	C84	Capacitor, 100 nF, 50 V	Murata	GRM188R71H104KA93D
11	1	C92	Capacitor, 22 pF, 50 V	Würth	885012005057

Table 5: Bill of Materials - EPC9513 Device Board (continued)

Item	Qty	Reference	Part Description	Manufacturer	Part #
12	1	CM1	Capacitor, 560 pF	Vishay	VJ1111D561KXDAT
13	1	CM2	Capacitor, 20 pF	Vishay	VJ1111D200JXRAJ
14	1	CM12	Capacitor, 680 pF	Vishay	VJ1111D681KXDAT
15	1	D51	Schottky Diode, 30 V, 500 mA	ST	STPS0530Z
16	1	D60	Schottky Diode, 100 V, 3 A	ST	STPS3H100UF
17	4	D80, D81, D82, D83	Schottky Diode, 40 V, 1 A	Diodes Inc.	PD3S140-7
18	1	D84	LED 0603 Green	Lite-On	LTST-C193KGKT-5A
19	1	D85	Zener Diode, 2.7 V, 250 mW	NXP	BZX84-C2V7,215
20	1	D86	LED 0603 Red	Lite-On	LTST-C193KRKT-5A
21	1	D87	Zener Diode, 33 V, 250 mW	NXP	BZX84-C33,215
22	1	D88	TVS Diode, 35 V, 8.2 A	Littelfuse	SMAJ30A
23	3	FD1, FD2, FD3	Fiducial	N/A	N/A
24	1	J1	Category 3 Coil	NuCurrent	NC20-R070L03E-079-063-0R71
25	1	J3	.1" Male Vert.	Amphenol FCI	95278-101A04LF
26	2	L60, L61	Inductor, 22 µH, 4.3 A	Vishay Dale	IHLP3232DZER220M11
27	1	L90	Inductor, 10 µH, 150 mA	Taiyo Yuden	LBR2012T100K
28	1	LE1	Inductor, 18 µH, 3.8 mA	Eaton	CMS1-4-R
29	2	LM1, LM11	Inductor, 32 nH	Würth	744912182
30	1	Q60	eGaN FET, 200 V, 9 A, 43 mΩ	EPC	EPC2019
31	1	R40	Resistor, 17.8 k Ω 1%, 1/10W	Panasonic	ERJ-3EKF1782V
32	1	R41	Resistor, 6.04 k Ω 1%, 1/10W	Panasonic	ERJ-2RKF6041X
33	1	R50	Resistor, 10 Ω 1%, 1/10W	Panasonic	ERJ-3EKF10R0V
34	1	R51	Resistor, 124 k Ω 1%, 1/10W	Panasonic	ERJ-2RKF1243X
35	1	R52	Resistor, 62 k Ω 1%, 1/10W	Panasonic	ERJ-2RKF6202X
36	1	R53	Resistor, 12 Ω 1%, 1/10W	Panasonic	ERJ-2RKF12R0X
37	1	R54	Resistor, 0 Ω JUMPER, 1/16W	Yageo	RC0402JR-070RL
38	1	R57	Resistor, 1 mΩ 1% 1/10W	Panasonic	ERJ-3EKF1004V
39	1	R58	Resistor, 150 k Ω 1%, 1/10W	Panasonic	ERJ-2RKF1503X
40	1	R60	Resistor, 40 mΩ 1%, 0.4W	Vishay Dale	WSP0603R0400FEB
41	1	R80	Resistor, 75 mΩ 1%, 2W	Stackpole	CSRN2512FK75L0
42	1	R81	Resistor, 4.7 k Ω 1%, 1/4W	Stackpole	RMCF1206FT4K70
43	1	R82	Resistor, 422 Ω 1%, 1/10W	Yageo	RMCF0603FT422R
44	1	R90	Resistor, 2.2 Ω 5%, 1/16W	Yageo	RC0402JR-072R2L
45	1	R92	Resistor, 20 Ω 5%, 1/16W	Stackpole	RMCF0402JT20R0
46	4	TP1, TP2, TP3, TP4	SMD Probe Loop, Keystone 5015	Keystone	36-5015TR-ND
47	1	U50	IC, Boost Controller	Texas Instruments	LM3481MM/NOPB
48	1	U90	IC, Gate Driver with LDO	Texas Instruments	UCC27611DRV

Table 6: Optional Components

Item	Qty	Reference	Part Description	Manufacturer	Part #
1	2	C54, R55	Capacitor, 0.022 µF, 50 V, X7R Resistor, 23.2 k Ω 1%, 1/10 W	Murata, Panasonic	GRM155R71H223KA12D, ERJ-2RKF2322X
2	1	C67	Capacitor, 10000 pF, 100 V, X7R	TDK	C1608X7R2A103K080AA
3	6	CM5, CM6, CM7, CM8, CMP3, CMP4	Optional Capacitor	TBD	
4	3	CM11, CMP1, CMP2	Optional Capacitor	TBD	
5	1	D67	Schottky Diode, 200 V	Diodes Inc.	DFLS1200
6	1	D90	Zener Diode, 5.1 V, 150 mW	Comchip Technology	CZRU52C5V1
7	1	GP60	CONN HEADER 1 POS 2.54	Würth	61300111121
8	1	J2	Connector	Amphenol FCI	
9	1	JP50	Connector		
10	1	PH60			
11	1	R67	Resistor, 10 k Ω 5%, 2/3W	Panasonic	ERJ-P08J103V

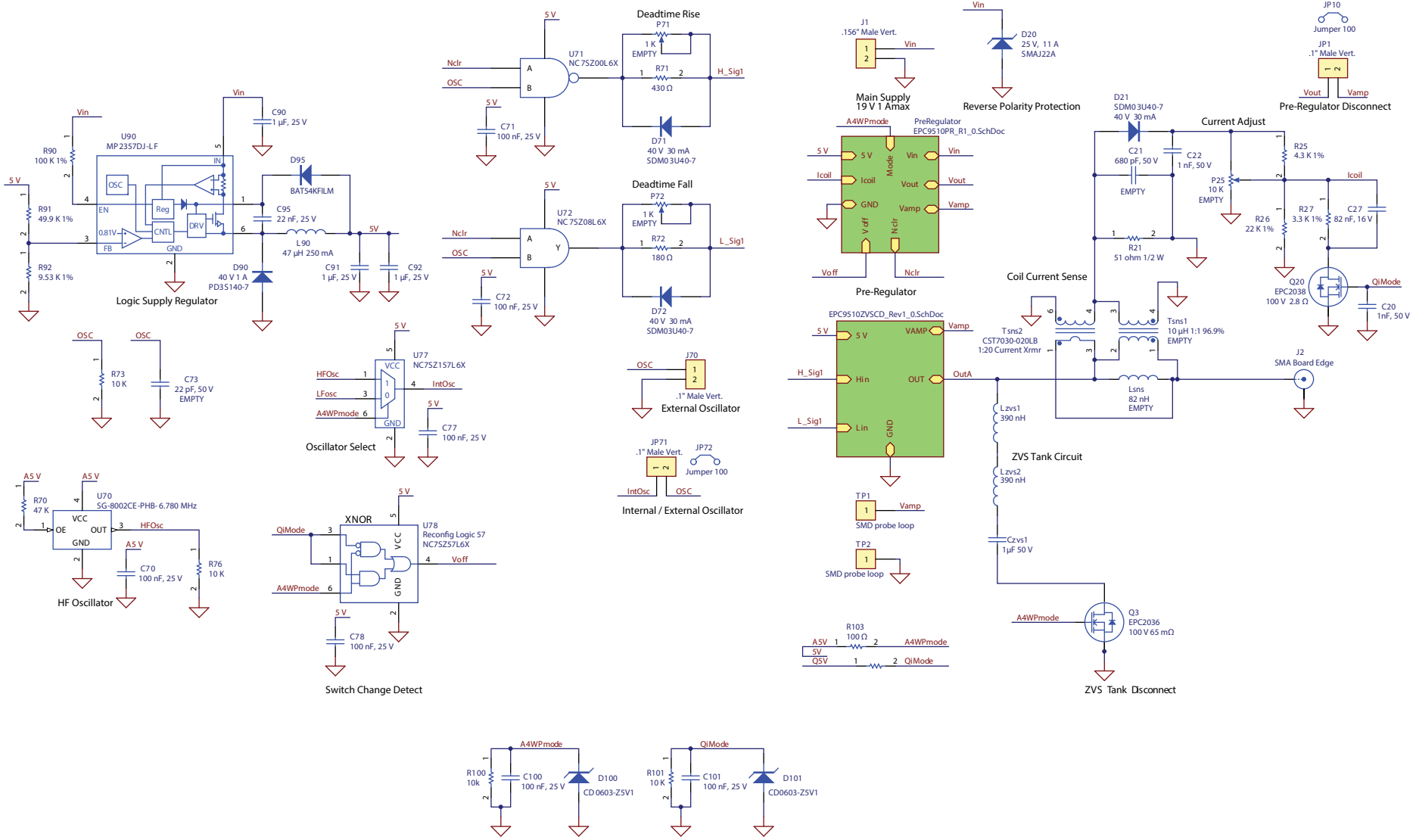

Figure 11: EPC9510-ZVS class-D schematic Rev 3.0

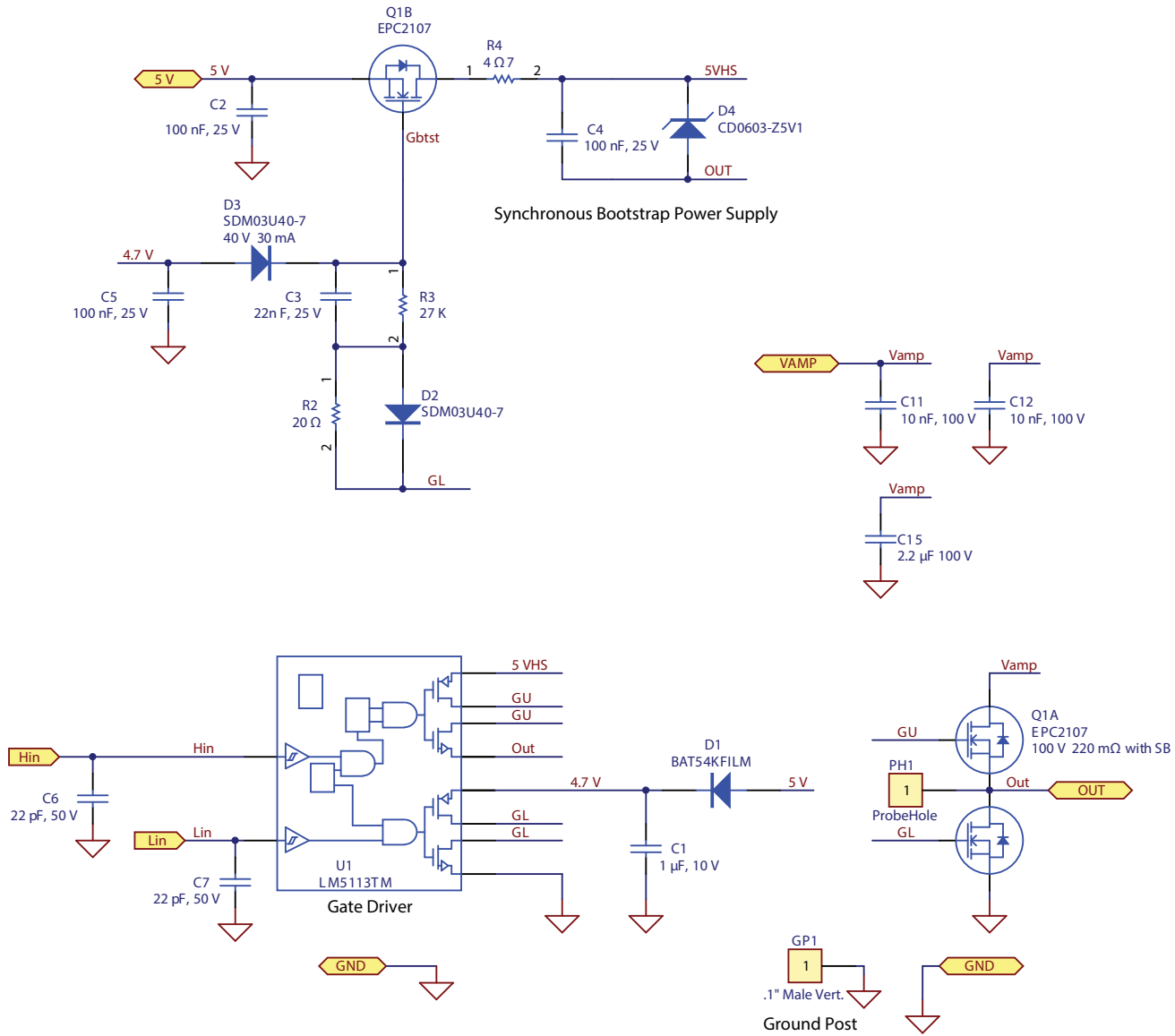

Figure 12: EPC9510- Gate driver and power devices schematic

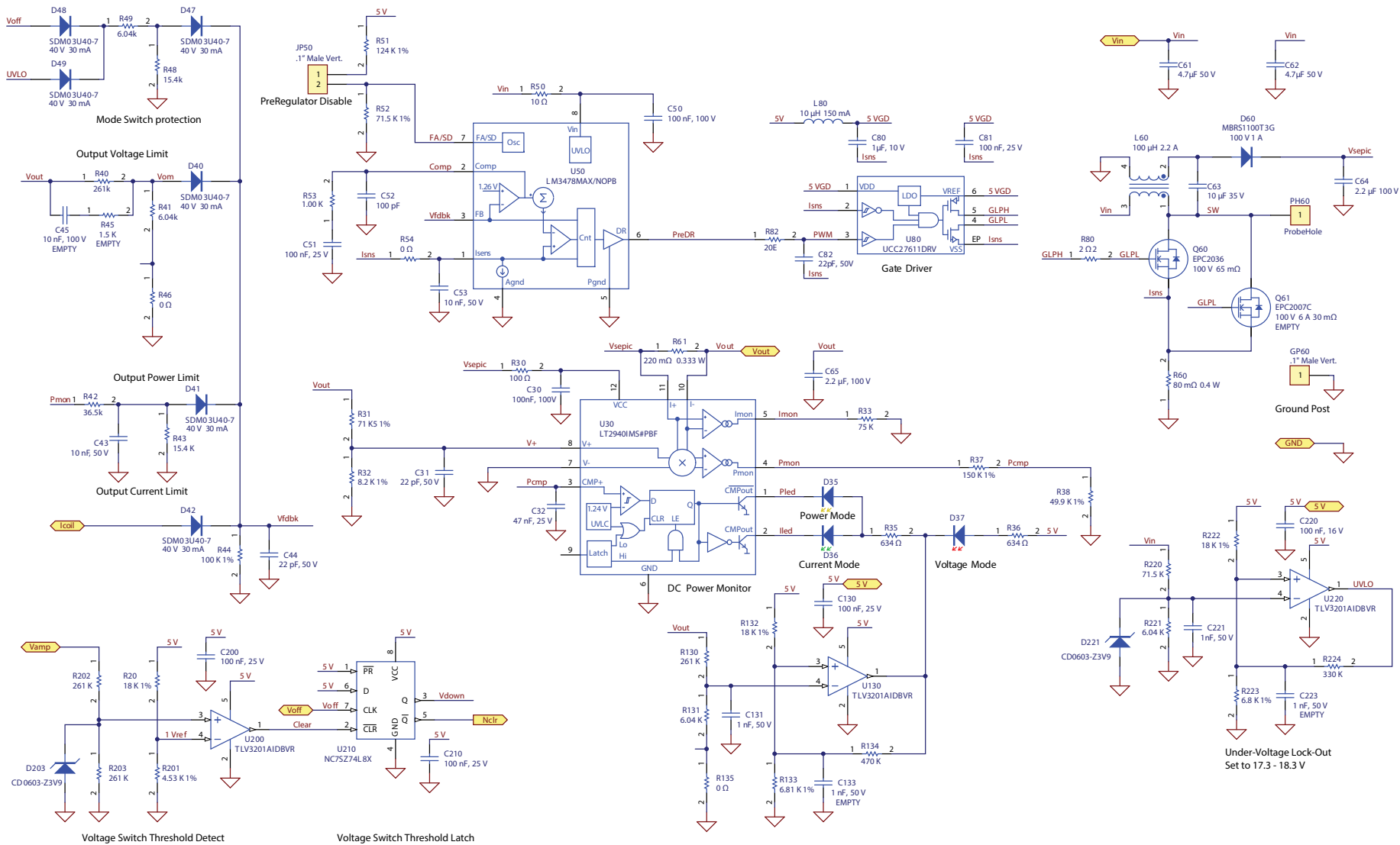

Figure 13: Pre-regulator schematic

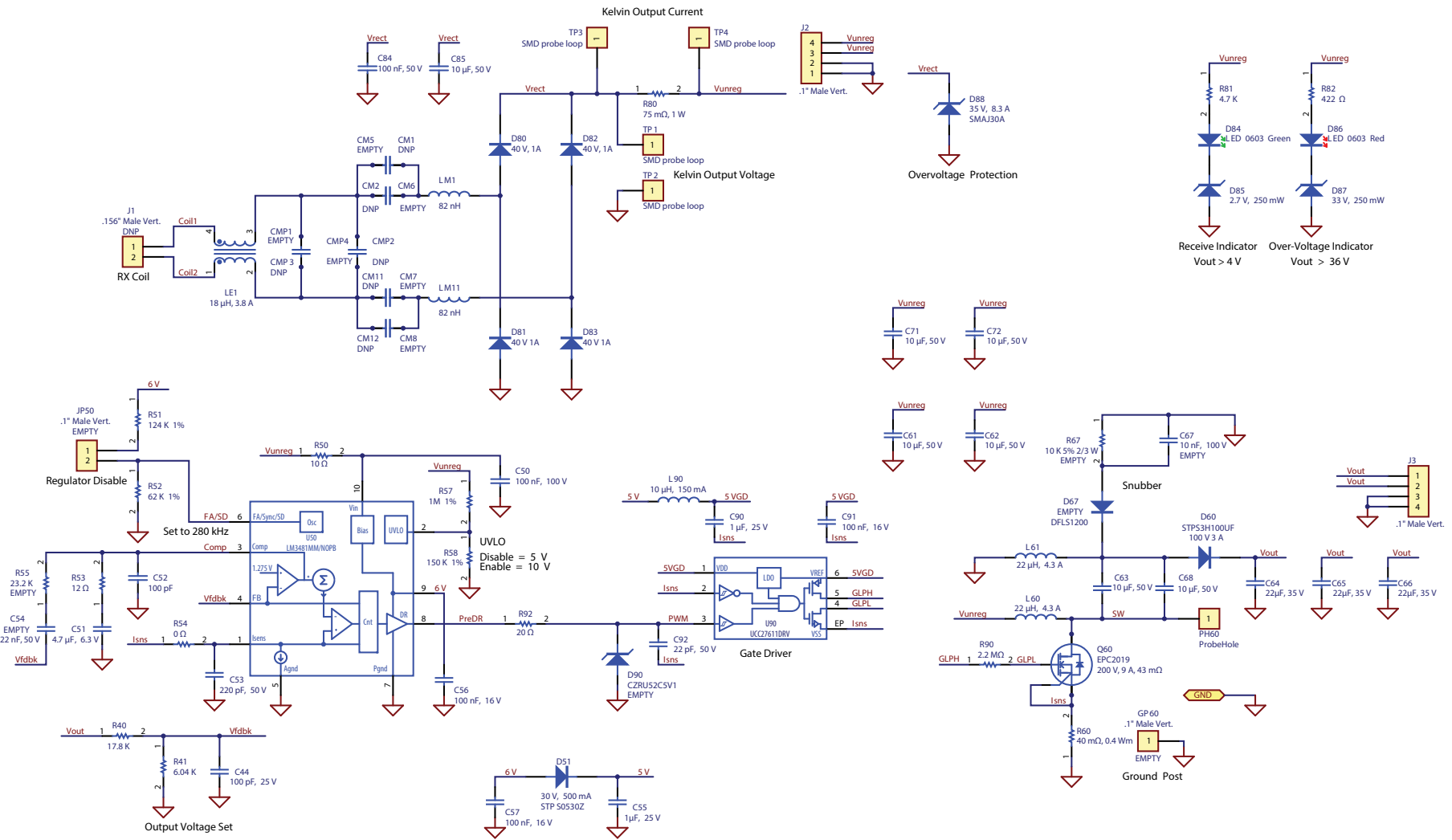

Figure 14: Category 3 device board schematic

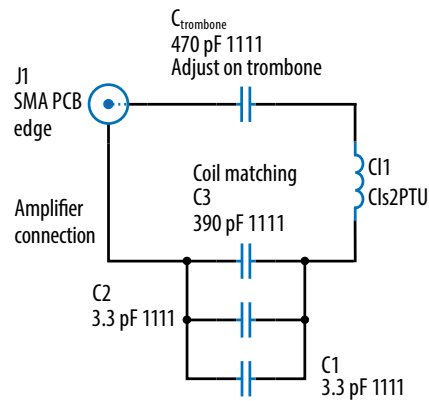

Figure 15: Class 2 Source Board Schematic



EPC would like to acknowledge Würth Elektronik (www.we-online.com) for their support of this project.

Würth Elektronik is a premier manufacturer of electronic and electromechanical passive components. EPC has partnered up with Würth Elektronik for a variety of passive component requirements due to the performance, quality and range of products available. The EPC9127 demonstration system features various Würth Elektronik product lines including capacitors, LEDs and connectors.

Also featured on the board are numerous Würth Elektronik power inductor technologies including WE-AIR air core inductors. The inductors were chosen for their balance between size, efficiency, current handling capability, reliability, and lowest DCR losses.

Learn more at www.we-online.com.



EPC would like to acknowledge NuCurrent (www.NuCurrent.com) for their support of this project.

NuCurrent is a leading developer of high-efficiency antennas for wireless power applications. Compliant across AirFuel Alliance and Wireless Power Consortium (Qi) standards, NuCurrent works closely with electronic device OEMs and integrators to custom-design, rapid-prototype and integrate the optimal antenna for a broad range of applications. NuCurrent's patented designs, structures and manufacturing techniques mitigate typical high frequency effects, offering higher efficiency, smaller sizes, higher durability and lower cost with wireless power application development.

For more information, visit www.nucurrent.com

For More Information:

Please contact info@epc-co.com
or your local sales representative

Visit our website:
www.epc-co.com

Sign-up to receive
EPC updates at
bit.ly/EPCupdates
or text "EPC" to 22828



EPC Products are distributed through Digi-Key.
www.digikey.com

Demonstration Board Notification

The EPC9127 board is intended for product evaluation purposes only and is not intended for commercial use. Replace components on the Evaluation Board only with those parts shown on the parts list (or Bill of Materials) in the Quick Start Guide. Contact an authorized EPC representative with any questions.

This board is intended to be used by certified professionals, in a lab environment, following proper safety procedures. Use at your own risk.

As an evaluation tool, this board is not designed for compliance with the European Union directive on electromagnetic compatibility or any other such directives or regulations. As board builds are at times subject to product availability, it is possible that boards may contain components or assembly materials that are not RoHS compliant. Efficient Power Conversion Corporation (EPC) makes no guarantee that the purchased board is 100% RoHS compliant.

The Evaluation board (or kit) is for demonstration purposes only and neither the Board nor this Quick Start Guide constitute a sales contract or create any kind of warranty, whether express or implied, as to the applications or products involved.

Disclaimer: EPC reserves the right at any time, without notice, to make changes to any products described herein to improve reliability, function, or design. EPC does not assume any liability arising out of the application or use of any product or circuit described herein; neither does it convey any license under its patent rights, or other intellectual property whatsoever, nor the rights of others.