

G1225 series

LOW NOISE

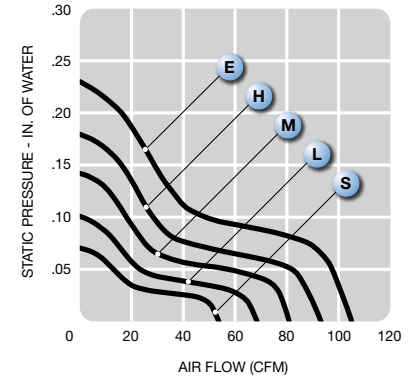
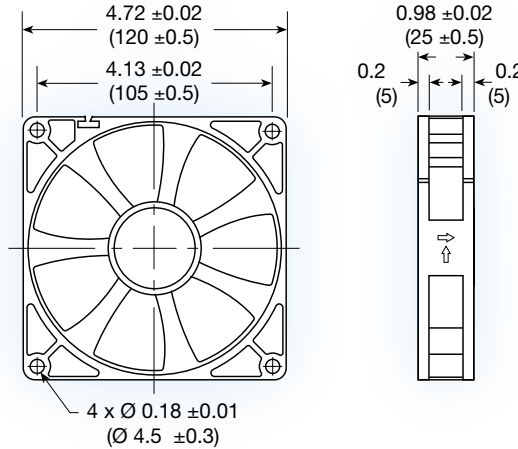

(120 x120 x 25 mm)
4.72 x4.72 x 0.98 inches

Construction:	UL94V-0 PBT impeller & frame
Bearing option:	ball bearing
Connection:	AWG 24, UL1007 lead wires
Frame:	flanged
Protection:	thermal
Options:	tachometer output or locked rotor alarm signal; thermistor control; encapsulated motor; PWM speed control

Model No.	Rated Voltage V	Current mA			Speed RPM	Air Volume		Max. Static Pressure (H ₂ O)		Sound Noise dbA	Weight g
		5	12	24		M ³ /Min.	CFM	MM	INCH		
G1225S	5/12/24	400	130	70	1,500	1.52	54	1.90	0.07	26	197
G1225L	5/12/24	620	230	120	1,800	1.87	66	2.60	0.10	29	197
G1225M	12/24	-	350	190	2,100	2.20	78	3.70	0.15	33	197
G1225H	12/24	-	480	270	2,400	2.46	87	4.50	0.18	38	197
G1225E	12/24	-	720	380	2,700	2.79	99	5.50	0.22	42	197

