



TERABEE

3Dcam 80x60

The compact and affordable
3D Time-of-Flight camera
for depth sensing applications

Build depth applications

Enable the third dimension with an 80x60 pixel resolution and 74° x 57° Field of View. The 3D Time-of-Flight camera benefits from a robust aluminium casing while still offering a compact (83 grams) and discreet design. It is easy to set up and to stream depth data via USB on Windows or Linux OS. An SDK and OpenNI code library is available to kick-start your application development.



Object & people
counting



Occupancy
monitoring



Fall detection



Hand gesture
recognition



Stock level
monitoring



Object
classification

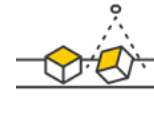

Object position
detection



Robotics
navigation

Key features

- Time-of-Flight technology
- 80 x 60 pixels depth image
- Large detection area (74° x 57°)
- Compact & lightweight design, only 83 grams with aluminum casing
- Comes with an SDK supporting Windows and Linux OS
- Compatible with OpenNI, C/C++, Python, ROS
- Privacy protected, non-intrusive data collection

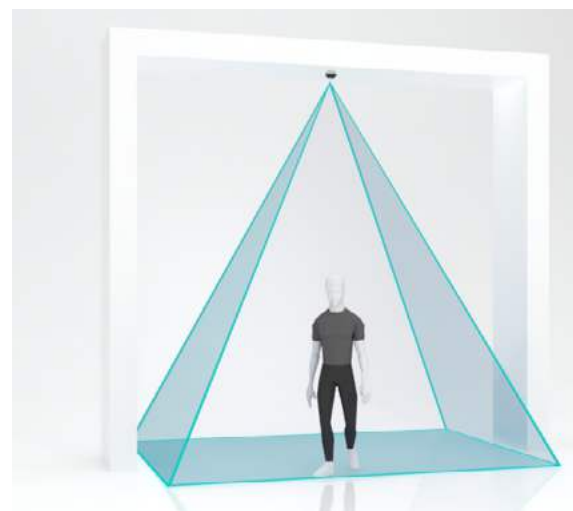

Technical specifications

Part Number	TB-3DCAM-8060-USB
Technology	Infrared Time-of-Flight
Resolution	80 x 60 pixels
Range	Close range mode: 0.2m to 1.2m; Standard mode: 1m to 4m
Field-of-View (H x V)	74° x 57°
Frame Rate	30 fps
Depth Resolution	1% of distance
Supply Voltage	5V DC (USB powered)
Power Consumption	4W
Operating Temperature	0°C to 40°C
Storage Temperature	-20°C to 60°C
Interfaces	USB 2.0 Micro-B
Weight	83g
Dimensions	54 x 53 x 24 mm
Use Environment	Indoors
Supporting OS	Windows, Linux
Software	Terabee SDK (OpenNI 1.5/2.2 based), C/C++ samples, Python samples, ROS package
Conformity	CE; RoHS

Back panel mounting
for discreet installations



Front panel mounting
for rapid prototyping projects

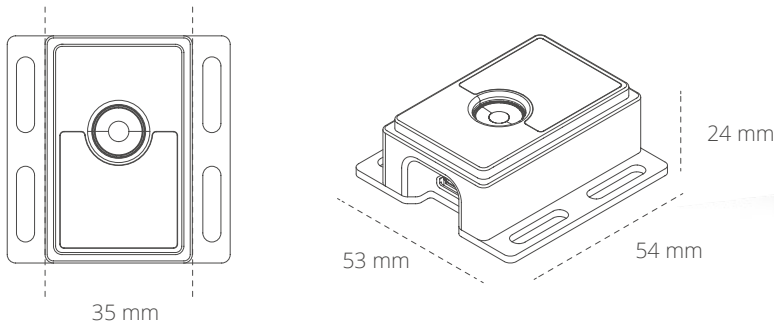

Time-of-Flight advantages

By using active Time-of-Flight technology to sense depth, the 3D camera collects non-intrusive depth image data, meaning that personal identity can never be captured. And, since the camera does not require ambient illumination for optimal performance, it is suitable for applications in low light or complete darkness.

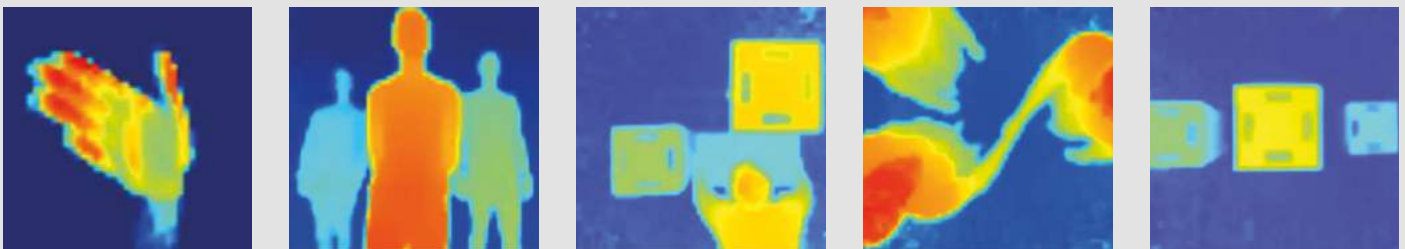

Address

Terabee, 90 Rue Henri Fabre
01630, St Genis-Pouilly, France
(next to CERN)

Contact

+33 7 50 15 16 64
teraranger@terabee.com
www.terabee.com