

THIS DRAWING IS UNPUBLISHED.
 DIFFUSION RESTREINTE
 © COPYRIGHT 20 BY -
 RELEASED FOR PUBLICATION
 LIBRE A LA DIFFUSION
 20
 ALL RIGHTS RESERVED.
 TOUS DROITS RESERVES

REVISIONS					
P	LTR	DESCRIPTION MODIFICATIONS	DATE	DWN DESS.	APVD APP.
	F2	PLATING NOTES CORRECTED	02AUG2016	KJK	PS

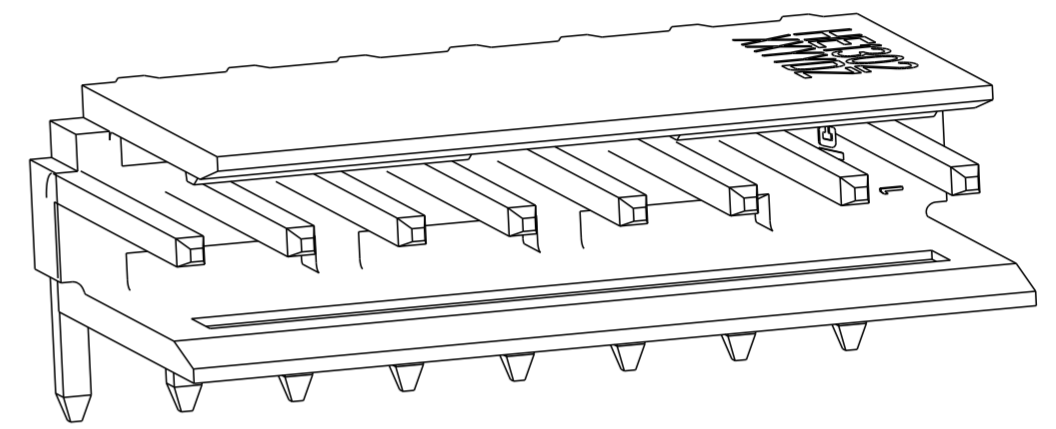

SCALE 6:1

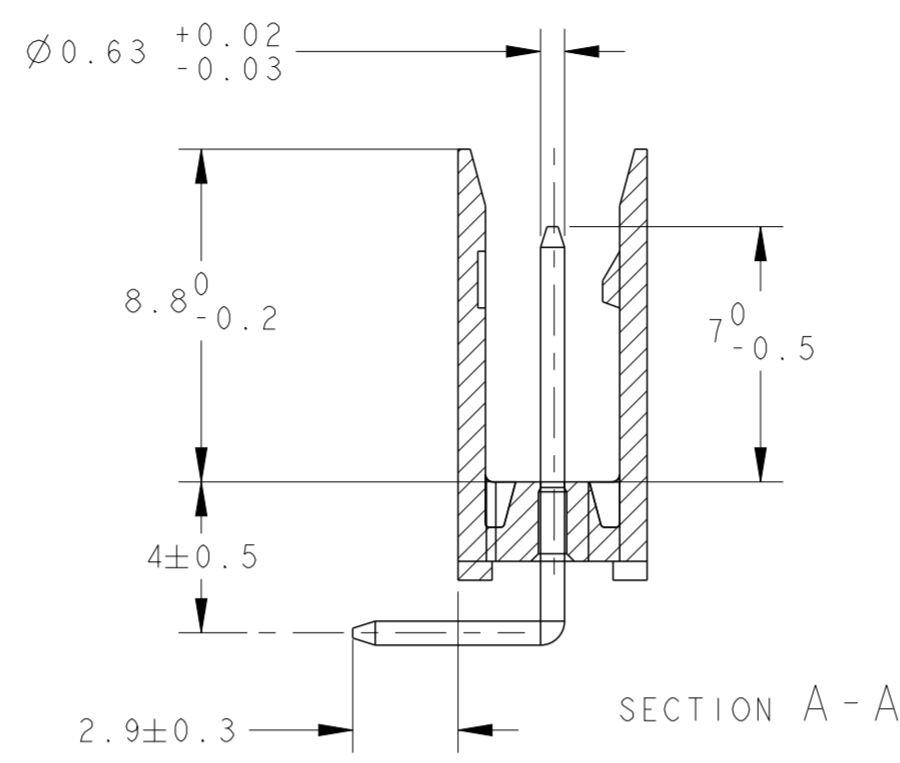
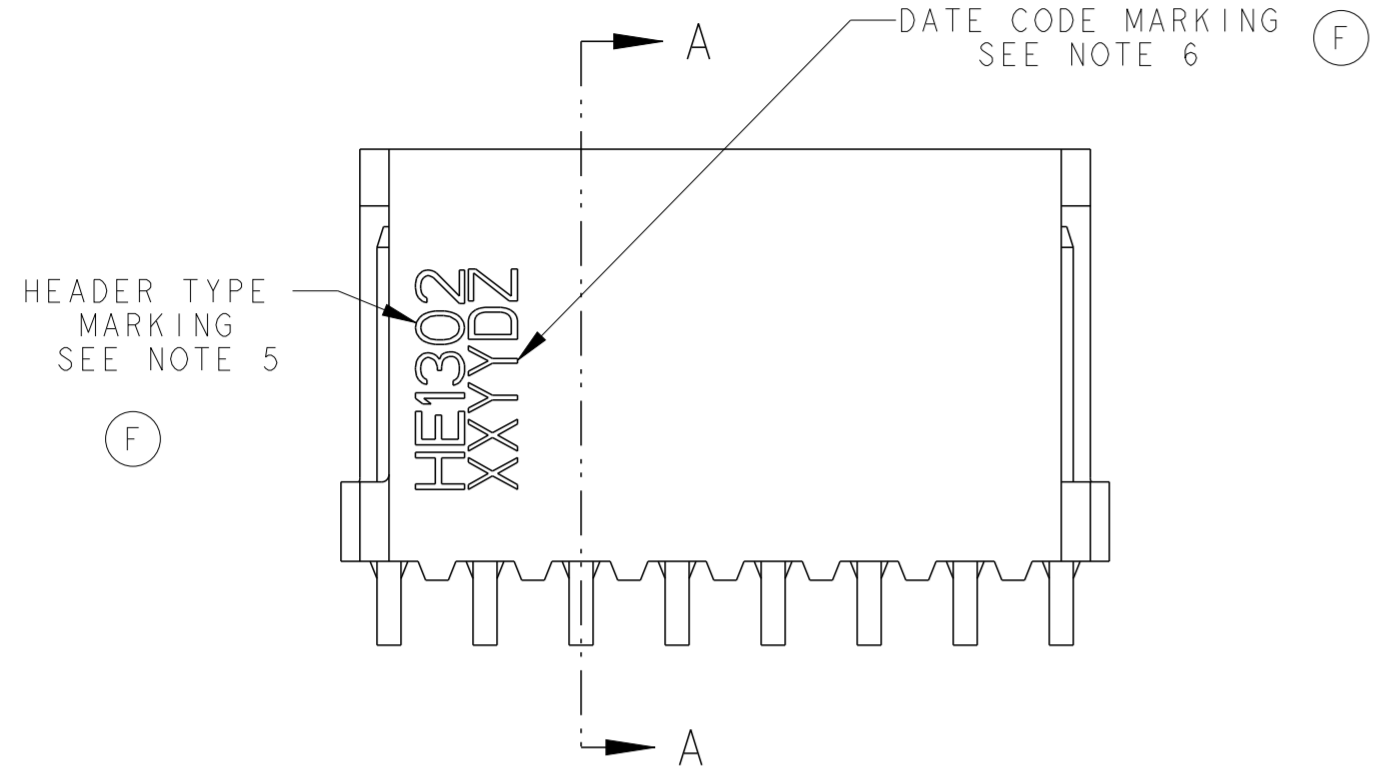
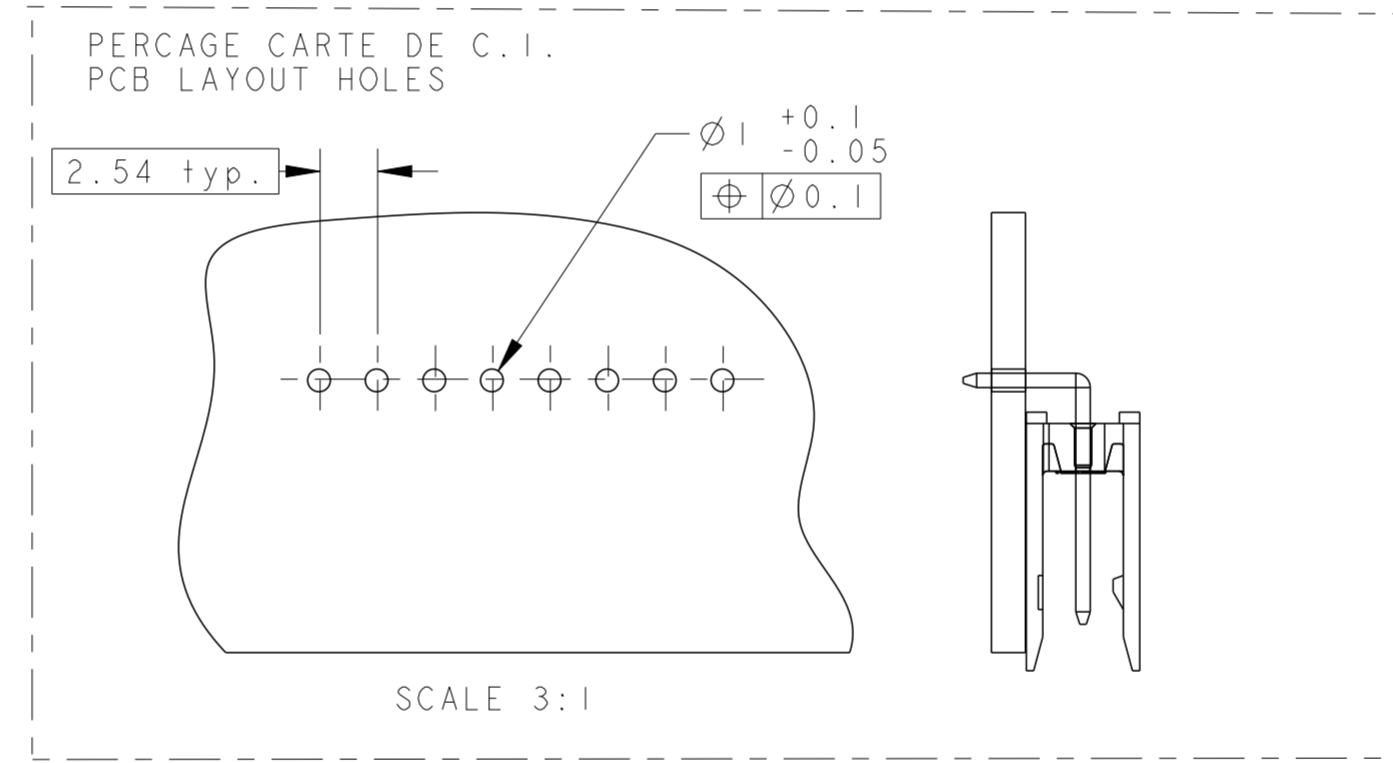
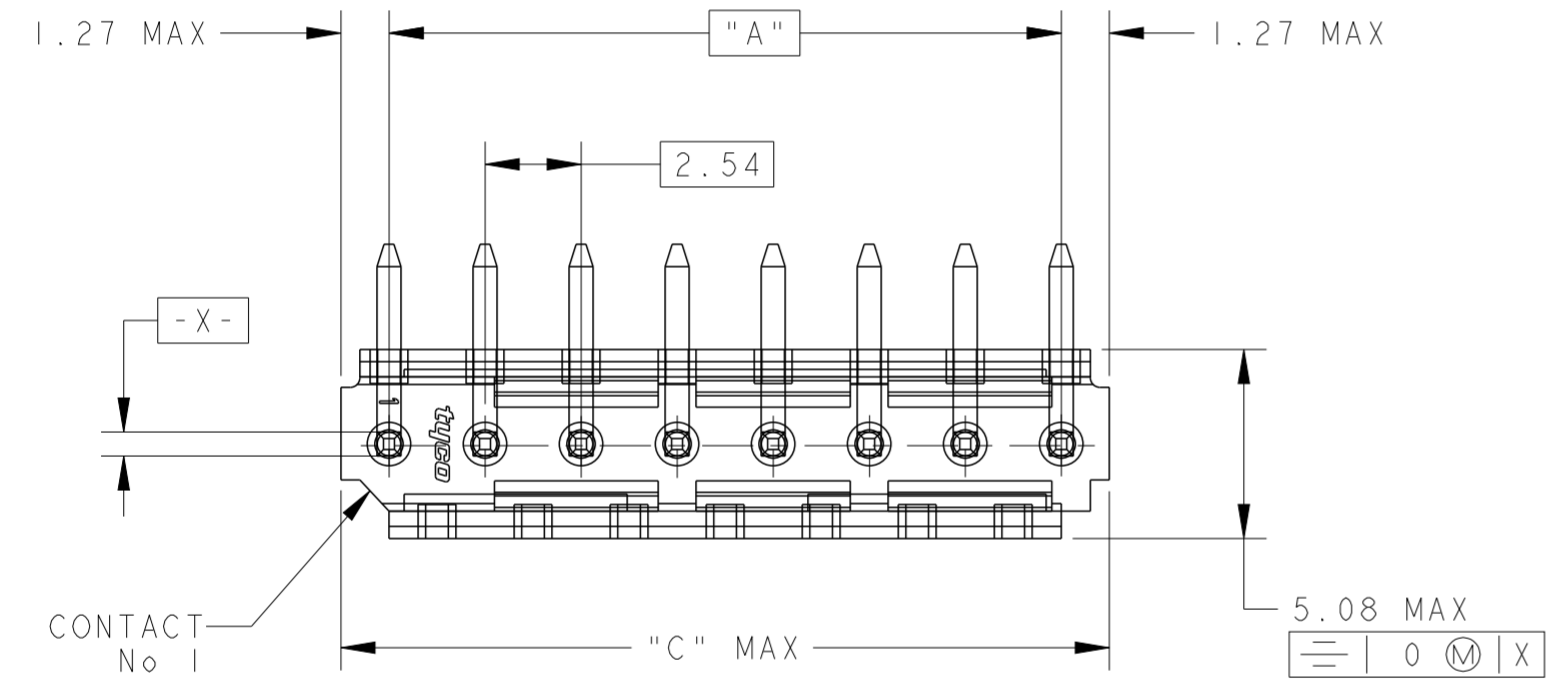

SCALE 3:1

7 OBSOLETE	45.72	43.18	18	1-281699-8 *
	43.18	40.64	17	1-281699-7
	38.10	35.56	15	1-281699-5 *
	30.48	27.94	12	1-281699-2 *
	25.40	22.86	10	1-281699-0 *
7 OBSOLETE	20.32	17.78	8	0-281699-8 *
	17.78	15.24	7	0-281699-7
	15.24	12.70	6	0-281699-6 *
	12.70	10.16	5	0-281699-5 *
	10.16	7.62	4	0-281699-4 *
	7.62	5.08	3	0-281699-3 *
	5.08	2.54	2	0-281699-2
	C	A	Nb DE POS	PART NUMBER
	DIMENSIONS			

- NOTES:
1. THESE HEADERS ARE DESIGNED TO BE MATED WITH "HE1302" RECEPTACLES SINGLE ROW
 2. THE PART NUMBERS FOLLOWED BY * ARE COVERED BY THE INTERNATIONAL STANDARD IEC 603-8
 3. CONTACTS PLATING: MATING AREA SELECTIVE GOLD MIN. 0.4µm OVER MIN. 1.27µm NICKEL
SOLDER AREA MIN. 2.5µm TIN OVER MIN. 1.27µm NICKEL
 4. PLASTIC MATERIAL: HIGH TEMPERATURE THERMOPLASTIC, UL-94V-0, BLUE COLOR
CONTACT MATERIAL: PHOSPHOR BRONZE
 5. TYPE MARKING (HE1302) WITH BLACK INK
 6. DATE CODE MARKING WITH BLACK INK

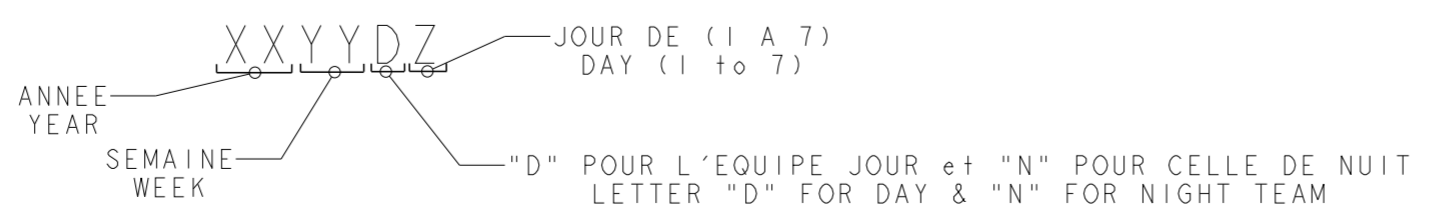

7 OBSOLETE PARTS: OBSOLETE CIS STREAMLINING PER D.RENAUD/D.SINISI

THIS DRAWING IS A CONTROLLED DOCUMENT. CE PLAN EST UN DOCUMENT CONTROLE PAR AMP INCORPORATED. IL EST SUSCEPTIBLE D'ETRE REVISE. CONTACTER LE SERVICE TECHNIQUE D'AMP DE FRANCE POUR OBTENIR LA DERNIERE REVISION.		DWN/DESSINE 22NOV2000 C. COMBEDOUZON CHK/VERIFIE 22NOV2000 T. CORRIOLU APVD/APPROUVE 22NOV2000 Y. PETRONIN		NAME TE Connectivity	
DIMENSIONS: mm		TOLERANCES UNLESS OTHERWISE SPECIFIED: TOLERANCES NON SPECIFIEES (SUIV NB DE DECIMALES) 0 PLC/DEC: ± 1 PLC/DEC: ±0.3 2 PLC/DEC: ± 3 PLC/DEC: ± 4 PLC/DEC: ± ANGLES ±5°		PRODUCT SPEC SPEC. PRODUIT 108-15053	
MATERIAL/MATIERE SEE/VOIR NOTE 4		FINISH/FINITION SEE/VOIR NOTE 3		APPLICATION SPEC SPEC. APPLICATION	
WEIGHT MASSE APPROX. -		SIZE FORMAT A2		CAGE CODE No PLAN C-281699	
CUSTOMER DRAWING /PLAN CLIENT		UNIQUEMENT POUR REFERENCE		SCALE ECHELLE 5:1	
SHEET FEUILLE 1		OF DE 1		REV F2	