



# Precision, 4-Channel/Dual 2-Channel, Low-Voltage, CMOS Analog Multiplexers

## General Description

The MAX4518/MAX4519 precision, monolithic, CMOS analog multiplexers (muxes) offer low on-resistance (less than  $100\Omega$ ), which is matched to within  $4\Omega$  between channels and remains flat over the specified analog signal range ( $10\Omega$  max). They also offer low leakage over temperature (NO-off leakage current less than  $2nA$  at  $+85^\circ C$ ) and fast switching speeds (transition time less than  $250ns$ ). The MAX4518 is a 4-channel device, and the MAX4519 is a dual 2-channel device.

The MAX4518/MAX4519 are fabricated with Maxim's low-voltage silicon-gate process. Design improvements yield extremely low charge injection (less than  $5pC$ ) and guarantee electrostatic discharge protection greater than  $2000V$ .

These muxes operate with a single  $+2.7V$  to  $+15V$  supply or with bipolar  $\pm 2.7V$  to  $\pm 8V$  supplies, while retaining CMOS-logic input compatibility and fast switching. CMOS inputs provide reduced input loading.

## Applications

Sample-and-Hold Circuits  
Automatic Test Equipment  
Heads-Up Displays  
Guidance and Control Systems  
Military Radios  
Communications Systems  
Battery-Operated Systems  
PBX, PABX  
Audio Signal Routing  
Low-Voltage Data-Acquisition Systems

## Features

- ♦ Guaranteed On-Resistance Match Between Channels ( $<4\Omega$ )
- ♦ Low On-Resistance ( $<100\Omega$ )
- ♦ Guaranteed Flat On-Resistance over Signal Range ( $<10\Omega$ )
- ♦ Guaranteed Low Charge Injection ( $<5pC$ )
- ♦ NO-Off Leakage Current  $<2nA$  at  $+85^\circ C$
- ♦ COM-Off Leakage Current  $<5nA$  at  $+85^\circ C$
- ♦ Electrostatic Discharge Protection  $>2000V$
- ♦ Single-Supply Operation ( $+2.7V$  to  $+15V$ )  
Bipolar-Supply Operation ( $\pm 2.7V$  to  $\pm 8V$ )
- ♦ Low Power Consumption ( $<300\mu W$ )
- ♦ Rail-to-Rail Signal Handling
- ♦ TTL/CMOS-Logic Compatible

## Ordering Information

PART	TEMP. RANGE	PIN-PACKAGE
MAX4518CPD	$0^\circ C$ to $+70^\circ C$	14 Plastic DIP
MAX4518CSD	$0^\circ C$ to $+70^\circ C$	14 SO
MAX4518CEE	$0^\circ C$ to $+70^\circ C$	16 QSOP
MAX4518C/D	$0^\circ C$ to $+70^\circ C$	Dice*
MAX4518EPD	$0^\circ C$ to $+70^\circ C$	14 Plastic DIP
MAX4518ESD	$-40^\circ C$ to $+85^\circ C$	14 SO
MAX4518EEE	$-40^\circ C$ to $+85^\circ C$	16 QSOP
MAX4518MJD	$-55^\circ C$ to $+125^\circ C$	14 CERDIP**

Ordering Information continued at end of data sheet.

\* Contact factory for dice specifications.

\*\* Contact factory for package availability.

## Pin Configurations

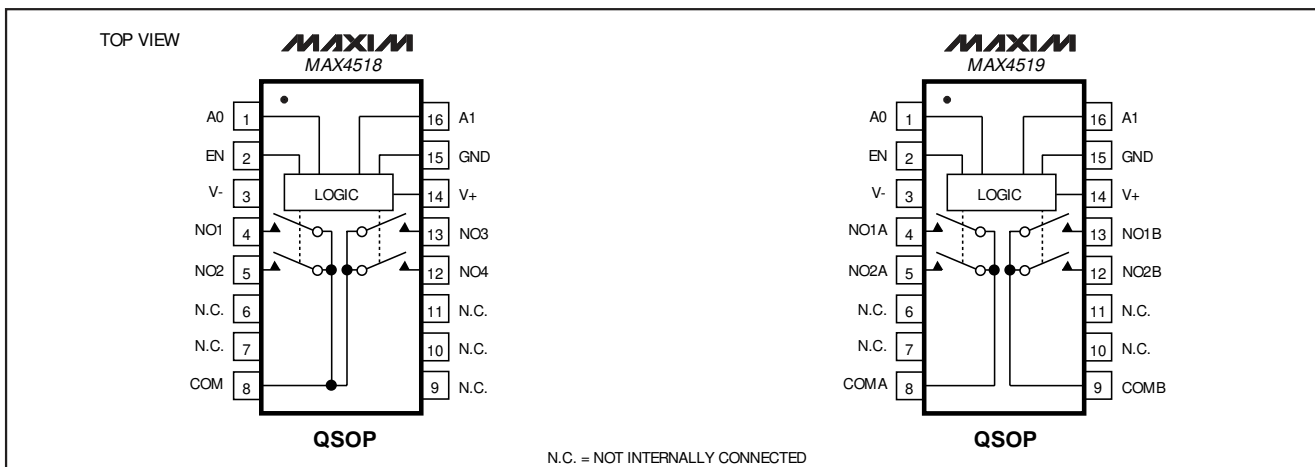

# Precision, 4-Channel/Dual 2-Channel, Low-Voltage, CMOS Analog Multiplexers

## ABSOLUTE MAXIMUM RATINGS

(Voltage Referenced to GND)

V+	.....-0.3V to +17V
V-	.....+0.3V to -17V
V+ to V-	.....-0.3V to +17V
Voltage into NO_, NC_ (Note 1)	.....(V- - 0.3V) to (V+ + 0.3V) or 30mA (whichever occurs first)
Voltage into EN, A0, A1 (Note 1)	.....(V- - 0.3V) to (V- + 17V)
Current into Any Terminal	.....30mA
Peak Current, Any Terminal (pulsed at 1ms, 10% duty cycle max)	.....40mA

Continuous Power Dissipation (T <sub>A</sub> = +70°C)	
Plastic DIP (derate 10.0mW/°C above +70°C)	.....800mW
Narrow SO (derate 8.0mW/°C above +70°C)	.....640mW
QSOP (derate 9.52mW/°C above +70°C)	.....762mW
CERDIP (derate 9.09mW/°C above +70°C)	.....727mW
Operating Temperature Ranges	
MAX4518C_/MAX4519C_	.....0°C to +70°C
MAX4518E_/MAX4519E_	.....-40°C to +85°C
MAX4518MJD/MAX4519MJD	.....-55°C to +125°C
Storage Temperature Range	.....-65°C to +150°C
Lead Temperature (soldering, 10sec)	.....+300°C

**Note 1:** Signals on any terminal exceeding V+ or V- are clamped by internal diodes. Limit forward current to maximum current ratings.

Stresses beyond those listed under "Absolute Maximum Ratings" may cause permanent damage to the device. These are stress ratings only, and functional operation of the device at these or any other conditions beyond those indicated in the operational sections of the specifications is not implied. Exposure to absolute maximum rating conditions for extended periods may affect device reliability.

## ELECTRICAL CHARACTERISTICS—Dual Supplies

(V+ = +4.5V to +5.5V, V- = -4.5V to -5.5V, GND = 0V, V<sub>AH</sub> = V<sub>ENH</sub> = 2.4V, V<sub>AL</sub> = V<sub>ENL</sub> = 0.8V, T<sub>A</sub> = T<sub>MIN</sub> to T<sub>MAX</sub>, unless otherwise noted.)

PARAMETER	SYMBOL	CONDITIONS		MIN	TYP (Note 2)	MAX	UNITS	
<b>SWITCH</b>								
Analog Signal Range	V <sub>COM</sub> , V <sub>NO</sub>	(Note 3)		V-		V+	V	
Channel On-Resistance	R <sub>ON</sub>	I <sub>NO</sub> = 1mA, V <sub>COM</sub> = ±3V	T <sub>A</sub> = +25°C		60	100	Ω	
			T <sub>A</sub> = T <sub>MIN</sub> to T <sub>MAX</sub>			125		
On-Resistance Matching Between Channels (Note 4)	ΔR <sub>ON</sub>	I <sub>NO</sub> = 1mA, V <sub>COM</sub> = ±3.5V, V+ = 5V, V- = -5V	T <sub>A</sub> = +25°C			4	Ω	
			T <sub>A</sub> = T <sub>MIN</sub> to T <sub>MAX</sub>			6		
On-Resistance Flatness (Note 5)	R <sub>FLAT(ON)</sub>	I <sub>NO</sub> = 1mA; V <sub>COM</sub> = ±3V, 0V; V+ = 5V; V- = -5V	T <sub>A</sub> = +25°C			10	Ω	
			T <sub>A</sub> = T <sub>MIN</sub> to T <sub>MAX</sub>			13		
NO-Off Leakage Current (Note 6)	I <sub>NO(OFF)</sub>	V <sub>NO</sub> = ±4.5V, V <sub>COM</sub> = ±4.5V, V+ = 5.5V, V- = -5.5V	T <sub>A</sub> = +25°C		-0.1	0.1	nA	
			T <sub>A</sub> = T <sub>MIN</sub> to T <sub>MAX</sub>	C, E	-2	2		
				M	-20	20		
COM-Off Leakage Current (Note 6)	I <sub>COM(OFF)</sub>	V <sub>COM</sub> = ±4.5V, V <sub>NO</sub> = ±4.5V, V+ = 5.5V, V- = -5.5V	MAX4518	T <sub>A</sub> = +25°C		-0.2	0.2	nA
				T <sub>A</sub> = T <sub>MIN</sub> to T <sub>MAX</sub>	C, E	-5	5	
				M	-40	40		
			MAX4519	T <sub>A</sub> = +25°C		-0.1	0.1	
				T <sub>A</sub> = T <sub>MIN</sub> to T <sub>MAX</sub>	C, E	-3	3	
				M	-20	20		
COM-On Leakage Current (Note 6)	I <sub>COM(ON)</sub>	V <sub>COM</sub> = ±4.5V, V <sub>NO</sub> = ±4.5V,	MAX4518	T <sub>A</sub> = +25°C		-0.4	0.4	nA
				T <sub>A</sub> = T <sub>MIN</sub> to T <sub>MAX</sub>	C, E	-10	10	
				M	-100	100		
			MAX4519	T <sub>A</sub> = +25°C		-0.2	0.2	
				T <sub>A</sub> = T <sub>MIN</sub> to T <sub>MAX</sub>	C, E	-5	5	
				M	-50	50		

# Precision, 4-Channel/Dual 2-Channel, Low-Voltage, CMOS Analog Multiplexers

MAX4518/MAX4519

## ELECTRICAL CHARACTERISTICS—Dual Supplies (continued)

(V<sub>+</sub> = +4.5V to +5.5V, V<sub>-</sub> = -4.5V to -5.5V, GND = 0V, V<sub>AH</sub> = V<sub>ENH</sub> = 2.4V, V<sub>AL</sub> = V<sub>ENL</sub> = 0.8V, T<sub>A</sub> = T<sub>MIN</sub> to T<sub>MAX</sub>, unless otherwise noted.)

PARAMETER	SYMBOL	CONDITIONS	MIN	TYP (Note 2)	MAX	UNITS
<b>DIGITAL LOGIC INPUT</b>						
Logic High Input Voltage	V <sub>AH</sub> , V <sub>ENH</sub>		T <sub>A</sub> = T <sub>MIN</sub> to T <sub>MAX</sub>		2.4	V <sub>+</sub> V
Logic Low Input Voltage	V <sub>AL</sub> , V <sub>ENL</sub>		T <sub>A</sub> = T <sub>MIN</sub> to T <sub>MAX</sub>		0	0.8 V
Input Current with Input Voltage High	I <sub>AH</sub> , I <sub>ENH</sub>	V <sub>A</sub> = V <sub>EN</sub> = 2.4V			-0.1	0.1 μA
Input Current with Input Voltage Low	I <sub>AL</sub> , I <sub>ENL</sub>	V <sub>A</sub> = V <sub>EN</sub> = 0.8V			-0.1	0.1 μA
<b>SUPPLY</b>						
Power-Supply Range	V <sub>+</sub> , V <sub>-</sub>				±2.7	±8 V
Positive Supply Current	I <sub>+</sub>	V <sub>EN</sub> = V <sub>A</sub> = 0V/V <sub>+</sub> , V <sub>+</sub> = 5.5V, V <sub>-</sub> = -5.5V	T <sub>A</sub> = +25°C		-1	1 μA
			T <sub>A</sub> = T <sub>MIN</sub> to T <sub>MAX</sub>		-10	10
Negative Supply Current	I <sub>-</sub>	V <sub>EN</sub> = V <sub>A</sub> = 0V/V <sub>+</sub> , V <sub>+</sub> = 5.5V, V <sub>-</sub> = -5.5V	T <sub>A</sub> = +25°C		-1	1 μA
			T <sub>A</sub> = T <sub>MIN</sub> to T <sub>MAX</sub>		-10	10
Ground Current	I <sub>GND</sub>	V <sub>EN</sub> = V <sub>A</sub> = 0V/V <sub>+</sub> , V <sub>+</sub> = 5.5V, V <sub>-</sub> = -5.5V	T <sub>A</sub> = +25°C		-1	1 μA
			T <sub>A</sub> = T <sub>MIN</sub> to T <sub>MAX</sub>		-10	10
<b>DYNAMIC</b>						
Transition Time	t <sub>TRANS</sub>	Figure 2	T <sub>A</sub> = +25°C			150 ns
			T <sub>A</sub> = T <sub>MIN</sub> to T <sub>MAX</sub>			250
Break-Before-Make Interval	t <sub>OPEN</sub>	Figure 4	T <sub>A</sub> = +25°C		0	40 ns
Enable Turn-On Time	t <sub>ON(EN)</sub>	Figure 3	T <sub>A</sub> = +25°C		60	150 ns
			T <sub>A</sub> = T <sub>MIN</sub> to T <sub>MAX</sub>			250
Enable Turn-Off Time	t <sub>OFF(EN)</sub>	Figure 3	T <sub>A</sub> = +25°C		40	150 ns
			T <sub>A</sub> = T <sub>MIN</sub> to T <sub>MAX</sub>			200
Charge Injection (Note 3)	Q	Figure 5, C <sub>L</sub> = 1.0nF, V <sub>S</sub> = 0V, R <sub>S</sub> = 0Ω	T <sub>A</sub> = +25°C		0	5 pC
Off Isolation (Note 7)	V <sub>ISO</sub>	Figure 6, V <sub>EN</sub> = 0V, R <sub>L</sub> = 1kΩ, f = 100kHz	T <sub>A</sub> = +25°C			-75 dB
Crosstalk Between Channels	V <sub>CT</sub>	Figure 6, V <sub>EN</sub> = 2.4V, f = 100kHz, V <sub>GEN</sub> = 1Vp-p, R <sub>L</sub> = 1kΩ	T <sub>A</sub> = +25°C			-92 dB
Logic Input Capacitance	C <sub>IN</sub>	f = 1MHz	T <sub>A</sub> = +25°C			8 pF
NO-Off Capacitance	C <sub>NO(OFF)</sub>	f = 1MHz, V <sub>EN</sub> = V <sub>D</sub> = 0V	T <sub>A</sub> = +25°C			5 pF
COM-Off Capacitance	C <sub>COM(OFF)</sub>	f = 1MHz, V <sub>EN</sub> = V <sub>D</sub> = 0V	T <sub>A</sub> = +25°C	MAX4518	16	pF
				MAX4519	10	
COM-On Capacitance	C <sub>COM(ON)</sub>	f = 1MHz, V <sub>EN</sub> = V <sub>D</sub> = 0V	T <sub>A</sub> = +25°C	MAX4518	27	pF
				MAX4519	17	

# Precision, 4-Channel/Dual 2-Channel, Low-Voltage, CMOS Analog Multiplexers

## ELECTRICAL CHARACTERISTICS—Single +5V Supply

(V<sub>+</sub> = +4.5V to +5.5V, V<sub>-</sub> = 0V, GND = 0V, V<sub>AH</sub> = V<sub>ENH</sub> = 2.4V, V<sub>AL</sub> = V<sub>ENL</sub> = 0.8V, T<sub>A</sub> = T<sub>MIN</sub> to T<sub>MAX</sub>, unless otherwise noted.)

PARAMETER	SYMBOL	CONDITIONS		MIN	TYP (Note 2)	MAX	UNITS	
<b>SWITCH</b>								
Analog Signal Range	V <sub>COM</sub> , V <sub>NO</sub>	(Note 3)		V <sub>-</sub>		V <sub>+</sub>	V	
On-Resistance	R <sub>ON</sub>	I <sub>NO</sub> = 1mA, V <sub>COM</sub> = 3.5V, V <sub>+</sub> = 4.5V	T <sub>A</sub> = +25°C		150	225	Ω	
			T <sub>A</sub> = T <sub>MIN</sub> to T <sub>MAX</sub>			280		
On-Resistance Matching Between Channels (Note 4)	ΔR <sub>ON</sub>	I <sub>NO</sub> = 1mA, V <sub>COM</sub> = 3V, V <sub>+</sub> = 4.5V	T <sub>A</sub> = +25°C			10	Ω	
			T <sub>A</sub> = T <sub>MIN</sub> to T <sub>MAX</sub>			12		
On-Resistance Flatness	R <sub>FLAT</sub>	I <sub>NO</sub> = 1mA; V <sub>COM</sub> = 3V, 2V, 1V; V <sub>+</sub> = 5V	T <sub>A</sub> = +25°C		10	19	Ω	
			T <sub>A</sub> = T <sub>MIN</sub> to T <sub>MAX</sub>		15	23		
NO-Off Leakage Current (Note 8)	I <sub>NO(OFF)</sub>	V <sub>NO</sub> = 4.5V, V <sub>COM</sub> = 0V, V <sub>+</sub> = 5.5V	T <sub>A</sub> = +25°C		-0.1	0.1	nA	
			T <sub>A</sub> = T <sub>MIN</sub> to T <sub>MAX</sub>	C, E	-1.0	1.0		
				M	-10	10		
COM-Off Leakage Current (Note 8)	I <sub>COM(OFF)</sub>	V <sub>COM</sub> = 4.5V, V <sub>NO</sub> = 0V, V <sub>+</sub> = 5.5V	MAX4518	T <sub>A</sub> = +25°C		-0.2	0.2	nA
				T <sub>A</sub> = T <sub>MIN</sub> to T <sub>MAX</sub>	C, E	-2.5	2.5	
				M	-20	20		
			MAX4519	T <sub>A</sub> = +25°C		-0.2	0.2	
				T <sub>A</sub> = T <sub>MIN</sub> to T <sub>MAX</sub>	C, E	-1.5	1.5	
				M	-10	10		
COM-On Leakage Current (Note 8)	I <sub>COM(ON)</sub>	V <sub>COM</sub> = 4.5V, V <sub>NO</sub> = 4.5V, V <sub>+</sub> = 5.5V	MAX4518	T <sub>A</sub> = +25°C		-0.4	0.4	nA
				T <sub>A</sub> = T <sub>MIN</sub> to T <sub>MAX</sub>	C, E	-5	5	
				M	-40	40		
			MAX4519	T <sub>A</sub> = +25°C		-0.2	0.2	
				T <sub>A</sub> = T <sub>MIN</sub> to T <sub>MAX</sub>	C, E	-2.5	2.5	
				M	-20	20		
<b>DIGITAL LOGIC INPUT</b>								
Logic High Input Voltage	V <sub>AH</sub> , V <sub>ENH</sub>		T <sub>A</sub> = T <sub>MIN</sub> to T <sub>MAX</sub>	2.4		V <sub>+</sub>	V	
Logic Low Input Voltage	V <sub>AL</sub> , V <sub>ENL</sub>		T <sub>A</sub> = T <sub>MIN</sub> to T <sub>MAX</sub>	0		0.8	V	
Input Current with Input Voltage High	I <sub>AH</sub> , I <sub>ENH</sub>	V <sub>A</sub> = V <sub>EN</sub> = 2.4V		-0.1		0.1	μA	
Input Current with Input Voltage Low	I <sub>AL</sub> , I <sub>ENL</sub>	V <sub>A</sub> = V <sub>EN</sub> = 0.8V		-0.1		0.1	μA	
<b>SUPPLY</b>								
Power-Supply Range	V <sub>+</sub>			2.7		15	V	
Positive Supply Current	I <sub>+</sub>	V <sub>EN</sub> = V <sub>A</sub> = 0V, V <sub>+</sub> ; V <sub>+</sub> = 5.5V; V <sub>-</sub> = 0V		-10		10	μA	
Negative Supply Current	I <sub>-</sub>	V <sub>EN</sub> = V <sub>A</sub> = 0V, V <sub>+</sub> ; V <sub>+</sub> = 5.5V; V <sub>-</sub> = 0V		-10		10	μA	
I <sub>GND</sub> Supply Current	I <sub>GND</sub>	V <sub>EN</sub> = V <sub>+</sub> , 0V; V <sub>A</sub> = 0V; V <sub>+</sub> = 5.5V; V <sub>-</sub> = 0V	T <sub>A</sub> = +25°C		-1.0	1.0	μA	
			T <sub>A</sub> = T <sub>MIN</sub> to T <sub>MAX</sub>		-10	10		

# Precision, 4-Channel/Dual 2-Channel, Low-Voltage, CMOS Analog Multiplexers

MAX4518/MAX4519

## ELECTRICAL CHARACTERISTICS—Single +5V Supply (continued)

(V<sub>+</sub> = +4.5V to +5.5V, V<sub>-</sub> = 0V, GND = 0V, V<sub>AH</sub> = V<sub>ENH</sub> = 2.4V, V<sub>AL</sub> = V<sub>ENL</sub> = 0.8V, T<sub>A</sub> = T<sub>MIN</sub> to T<sub>MAX</sub>, unless otherwise noted.)

PARAMETER	SYMBOL	CONDITIONS	MIN	TYP (Note 2)	MAX	UNITS
<b>DYNAMIC</b>						
Transition Time	t <sub>TRANS</sub>	V <sub>NO</sub> = 3V		90	245	ns
Break-Before-Make Interval	t <sub>OPEN</sub>		T <sub>A</sub> = +25°C	10	40	ns
Enable Turn-On Time	t <sub>ON(EN)</sub>		T <sub>A</sub> = +25°C	90	200	ns
			T <sub>A</sub> = T <sub>MIN</sub> to T <sub>MAX</sub>		275	
Enable Turn-Off Time	t <sub>OFF(EN)</sub>		T <sub>A</sub> = +25°C	50	125	ns
			T <sub>A</sub> = T <sub>MIN</sub> to T <sub>MAX</sub>		200	
Charge Injection (Note 3)	Q	C <sub>L</sub> = 1.0nF, V <sub>S</sub> = 0V, R <sub>S</sub> = 0Ω	T <sub>A</sub> = +25°C	0	5	pC

## ELECTRICAL CHARACTERISTICS—Single +3V Supply

(V<sub>+</sub> = +2.7V to +3.3V, V<sub>-</sub> = 0V, GND = 0V, V<sub>AH</sub> = V<sub>ENH</sub> = 2.4V, V<sub>AL</sub> = V<sub>ENL</sub> = 0.8V, T<sub>A</sub> = T<sub>MIN</sub> to T<sub>MAX</sub>, unless otherwise noted.)

PARAMETER	SYMBOL	CONDITIONS	MIN	TYP (Note 2)	MAX	UNITS
<b>SWITCH</b>						
Analog Signal Range	V <sub>ANALOG</sub>	(Note 3)	V <sub>-</sub>		V <sub>+</sub>	V
On-Resistance	R <sub>ON</sub>	I <sub>NO</sub> = 0.1mA, V <sub>COM</sub> = 1.5V, V <sub>+</sub> = 3V	T <sub>A</sub> = +25°C	230	375	Ω
			T <sub>A</sub> = T <sub>MIN</sub> to T <sub>MAX</sub>		425	
<b>DYNAMIC</b>						
Transition Time (Note 3)	t <sub>TRANS</sub>	Figure 1, V <sub>IN</sub> = 2.4V, V <sub>INL</sub> = 0V, V <sub>N01</sub> = 1.5V	T <sub>A</sub> = +25°C	230	575	ns
Enable Turn-On Time (Note 3)	t <sub>ON(EN)</sub>	Figure 3, V <sub>INH</sub> = 2.4V, V <sub>INL</sub> = 0V, V <sub>N01</sub> = 1.5V	T <sub>A</sub> = +25°C	200	500	ns
Enable Turn-Off Time (Note 3)	t <sub>OFF(EN)</sub>	Figure 3, V <sub>INH</sub> = 2.4V, V <sub>INL</sub> = 0V, V <sub>N01</sub> = 1.5V	T <sub>A</sub> = +25°C	75	400	ns
Charge Injection (Note 3)	Q	Figure 5, C <sub>L</sub> = 1.0nF, V <sub>S</sub> = 0V, R <sub>S</sub> = 0Ω	T <sub>A</sub> = +25°C	0	5	pC

**Note 2:** The algebraic convention, where the most negative value is a minimum and the most positive value a maximum, is used in this data sheet.

**Note 3:** Guaranteed by design.

**Note 4:** ΔR<sub>ON</sub> = R<sub>ON(max)</sub> - R<sub>ON(min)</sub>.

**Note 5:** Flatness is defined as the difference between the maximum and minimum value of on-resistance as measured over the specified analog signal ranges; i.e., V<sub>NO</sub> = 3V to 0V and 0V to -3V.

**Note 6:** Leakage parameters are 100% tested at maximum rated hot operating temperature, and guaranteed by correlation at +25°C.

**Note 7:** Worst-case isolation is on channel 4 because of its proximity to the COM pin. Off isolation = 20log V<sub>COM</sub>/V<sub>NO</sub>, V<sub>COM</sub> = output, V<sub>NO</sub> = input to off switch.

**Note 8:** Leakage testing at single supply is guaranteed by correlation testing with dual supplies.

# Precision, 4-Channel/Dual 2-Channel, Low-Voltage, CMOS Analog Multiplexers

## Typical Operating Characteristics

( $T_A = +25^\circ\text{C}$ , unless otherwise noted.)

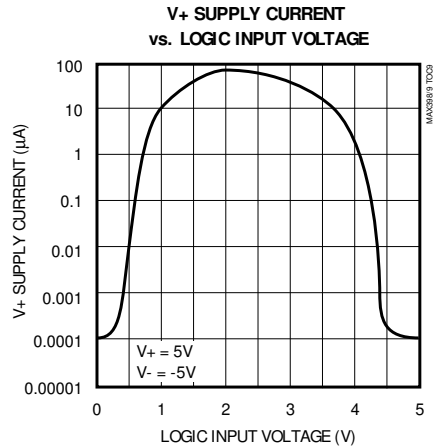
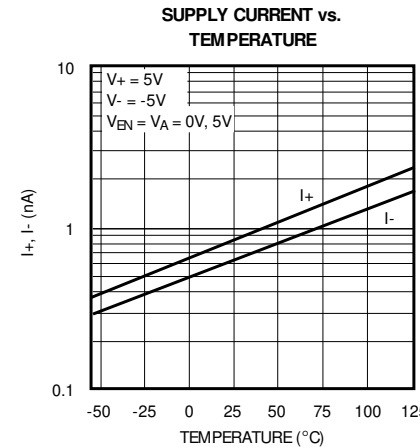
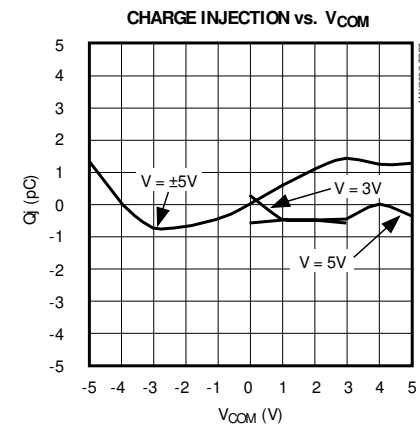
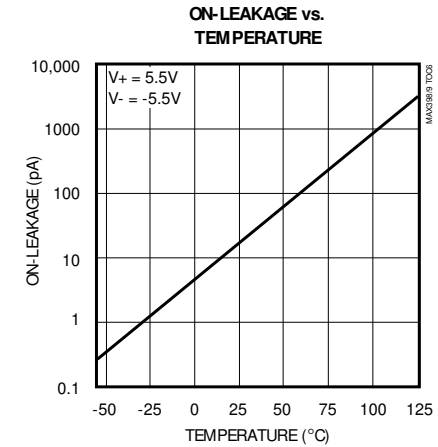
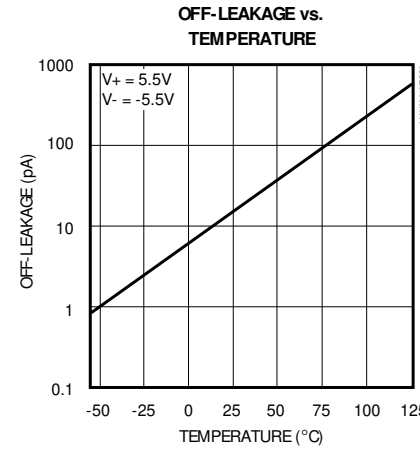
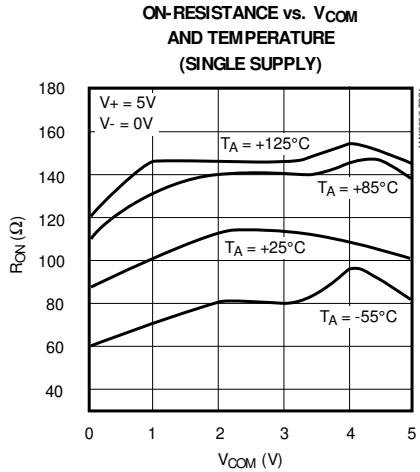
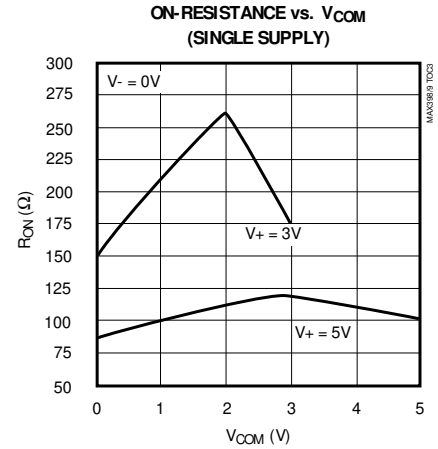
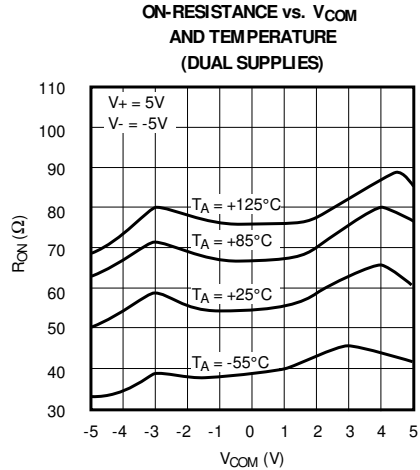
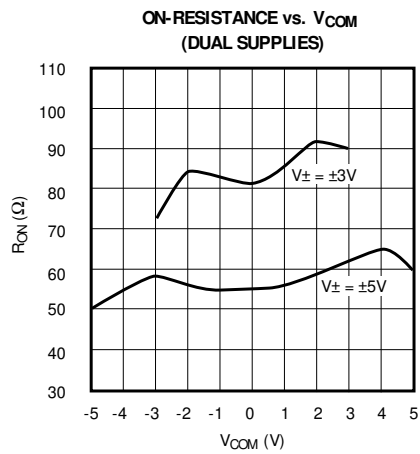

# Precision, 4-Channel/Dual 2-Channel, Low-Voltage, CMOS Analog Multiplexers

## Pin Description

MAX4518/MAX4519

PIN				NAME	FUNCTION
MAX4518		MAX4519			
DIP/SO	QSOP	DIP/SO	QSOP		
1	1	1	1	A0	Address 0 Logic Input
2	2	2	2	EN	Enable Logic Input
3	3	3	3	V-	Negative Supply Voltage Input. Connect to GND for single-supply operation.
4	4	—	—	NO1	Analog Signal Normally Open number 1
5	5	—	—	NO2	Analog Signal Normally Open number 2
—	—	4	4	NO1A	Analog Signal Normally Open number 1 -A switch
—	—	5	5	NO2A	Analog Signal Normally Open number 2 -A switch
—	—	6	8	COMA	Analog Signal Common -A switch
6	8	—	—	COM	Analog Signal Common
7, 8, 9	6, 7, 9, 10, 11	7, 8	6, 7, 10, 11	N.C.	Not internally connected
—	—	9	9	COMB	Analog Signal Common -B switch
—	—	10	12	NO2B	Analog Signal Normally Open number 2 -B switch
—	—	11	13	NO1B	Analog Signal Normally Open number 1 -B switch
10	12	—	—	NO4	Analog Signal Normally Open number 4
11	13	—	—	NO3	Analog Signal Normally Open number 3
12	14	12	14	V+	Positive Supply Voltage Input
13	15	13	15	GND	Logic Ground Input
14	16	14	16	A1	Address 1 Logic Input

# Precision, 4-Channel/Dual 2-Channel, Low-Voltage, CMOS Analog Multiplexers

## Applications Information

### Operation with Supply Voltages Other than $\pm 5V$

Using supply voltages less than  $\pm 5V$  reduces the analog signal range. The MAX4518/MAX4519 muxes operate with  $\pm 2.7V$  to  $\pm 8V$  bipolar supplies or with a  $+2.7V$  to  $+15V$  single supply. Connect  $V^-$  to GND when operating with a single supply. Both device types can also operate with unbalanced supplies, such as  $+10V$  and  $-5V$ . The *Typical Operating Characteristics* graphs show typical on-resistance with  $\pm 3V$ ,  $\pm 5V$ ,  $+3V$  and  $+5V$  supplies. (Switching times increase by a factor of two or more for operation at  $5V$ .)

### Overvoltage Protection

Proper power-supply sequencing is recommended for all CMOS devices. Do not exceed the absolute maximum ratings, because stresses beyond the listed ratings can cause permanent damage to the devices. Always sequence  $V^+$  on first, then  $V^-$ , followed by the logic inputs, NO, or COM. If power-supply sequencing is not possible, add two small signal diodes ( $D1$ ,  $D2$ ) in series with supply pins for overvoltage protection (Figure 1). Adding diodes reduces the analog signal range to one diode drop below  $V^+$  and one diode drop

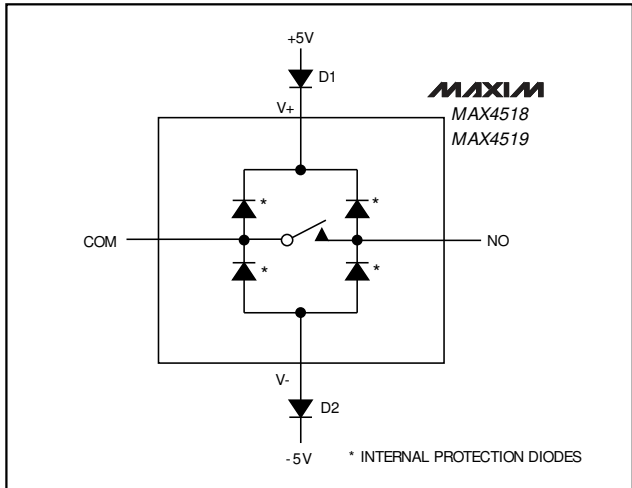

Figure 1. Overvoltage Protection Using External Blocking Diodes

above  $V^-$ , but does not affect the devices' low switch resistance and low leakage characteristics. Device operation is unchanged, and the difference between  $V^+$  and  $V^-$  should not exceed  $17V$ . These protection diodes are not recommended when using a single supply.

## Test Circuits/Timing Diagrams

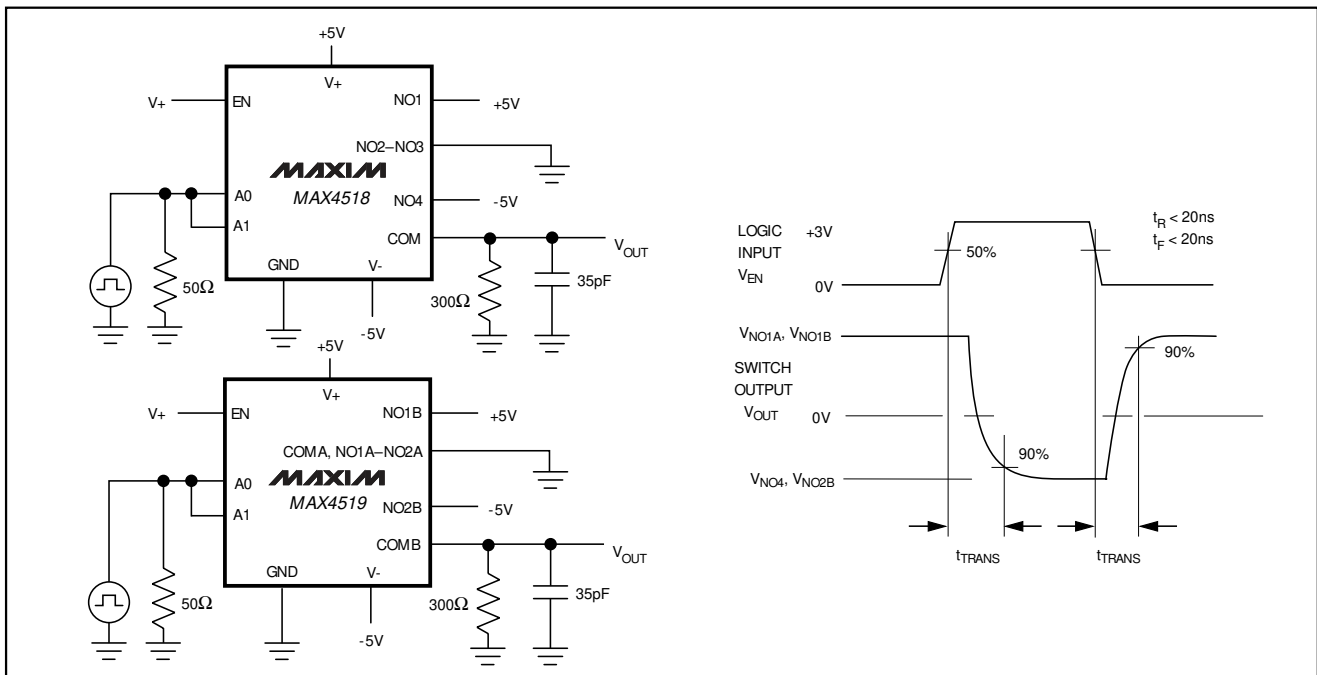

Figure 2. Transition Time



# Precision, 4-Channel/Dual 2-Channel, Low-Voltage, CMOS Analog Multiplexers

## Test Circuits/Timing Diagrams (continued)

MAX4518/MAX4519

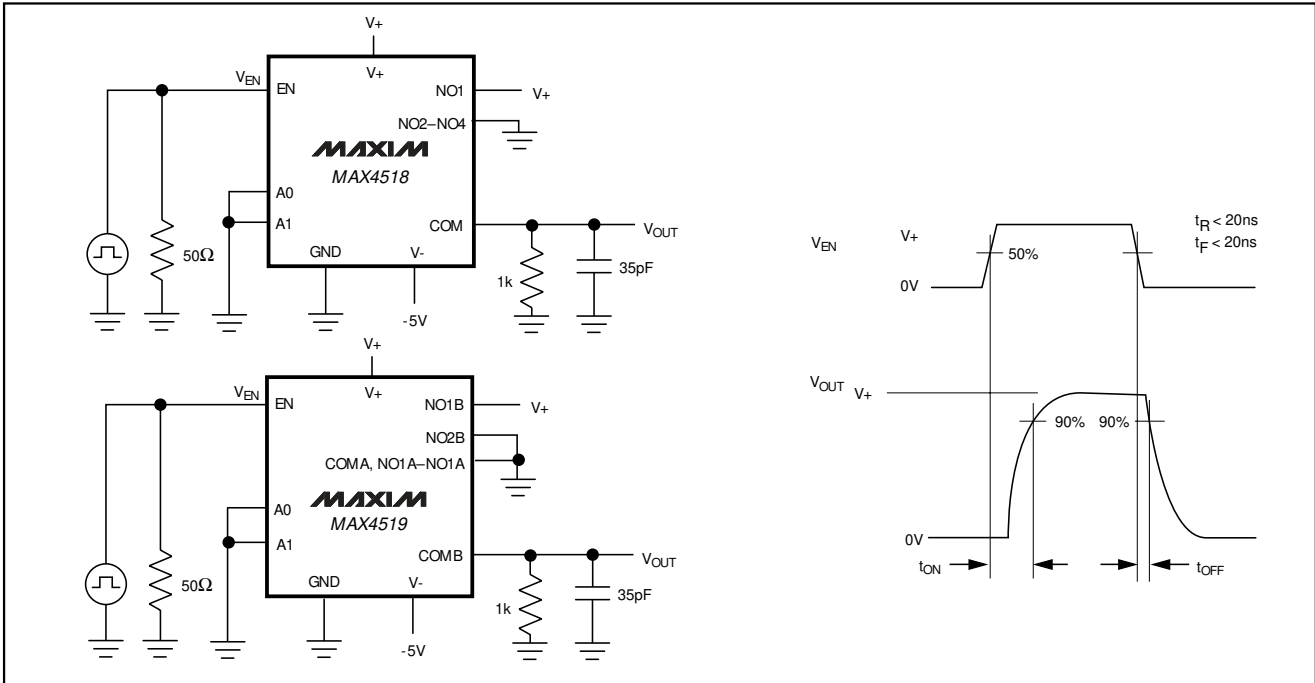

Figure 3. Enable Switching Time

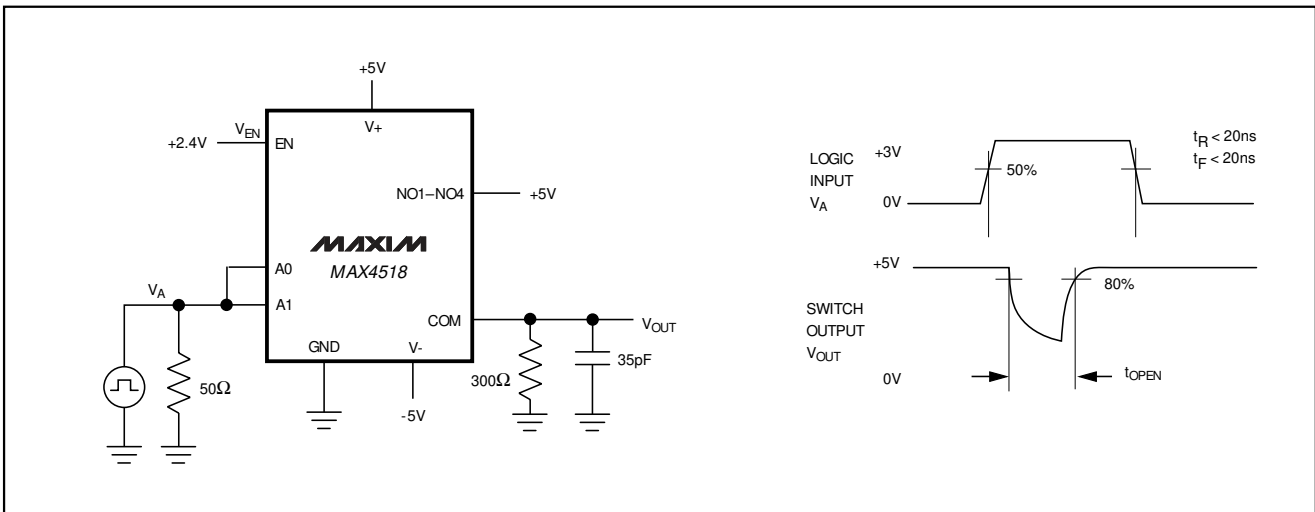

Figure 4. Break-Before-Make Interval

# Precision, 4-Channel/Dual 2-Channel, Low-Voltage, CMOS Analog Multiplexers

## Test Circuits/Timing Diagrams (continued)

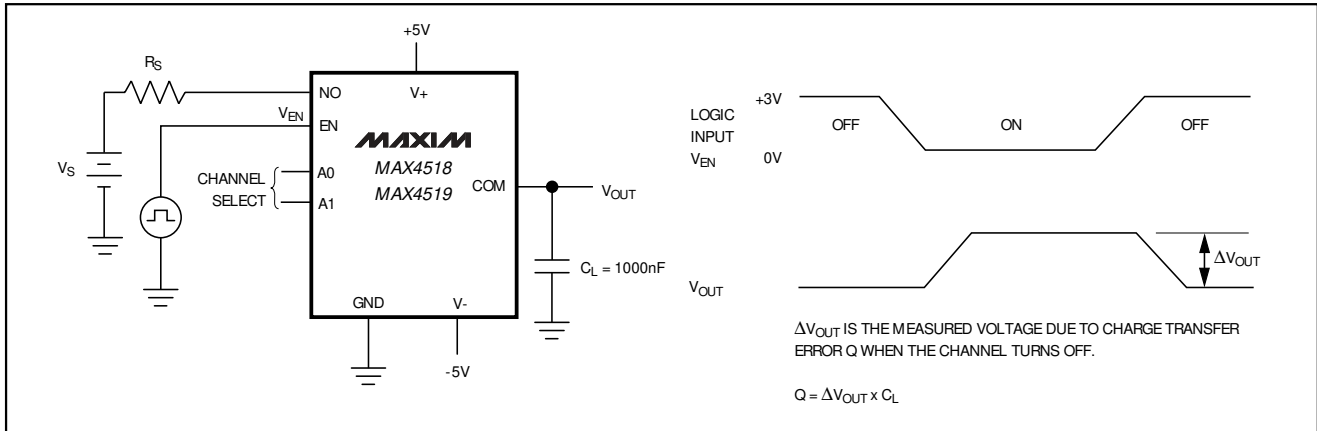

Figure 5. Charge Injection

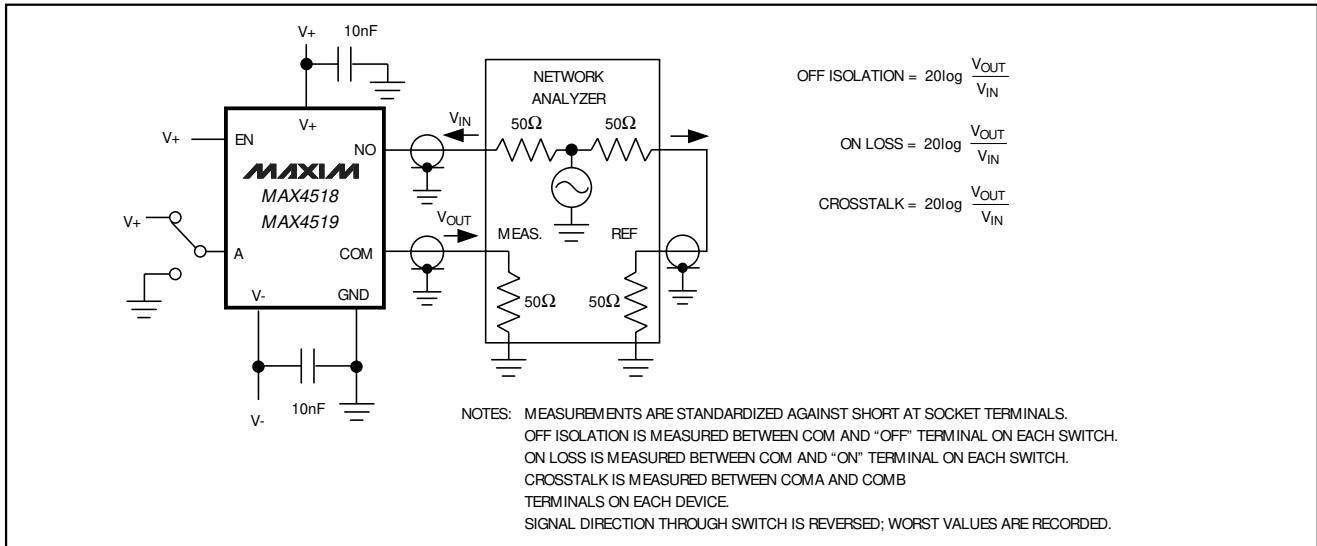

Figure 6. Off Isolation, On Loss, Crosstalk

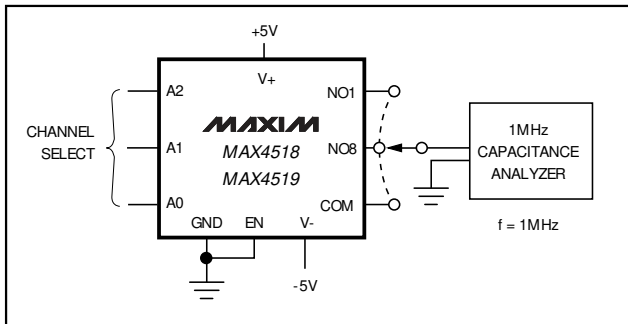

Figure 7. NO/COM Capacitance

# Precision, 4-Channel/Dual 2-Channel, Low-Voltage, CMOS Analog Multiplexers

## Functional Diagrams/Truth Tables

MAX4518/MAX4519

**MAX4518**

MAX4518			
A1	A0	EN	ON SWITCH
X	X	0	NONE
0	0	1	NO1
0	1	1	NO2
1	0	1	NO3
1	1	1	NO4

**MAX4519**

MAX4519			
A1	A0	EN	ON SWITCH
X	X	0	NONE
0	0	1	NO1A, NO1B
0	1	1	NO2A, NO1B
1	0	1	NO1A, NO2B
1	1	1	NO2A, NO2B

LOGIC "0"  $V_{AL} \leq +0.8\text{ V}$ , LOGIC "1"  $V_{AH} \geq +2.4\text{ V}$

## Pin Configurations (continued)

TOP VIEW

**MAX4518**

DIP/SO

**MAX4519**

DIP/SO

N.C. = NOT INTERNALLY CONNECTED

# Precision, 4-Channel/Dual 2-Channel, Low-Voltage, CMOS Analog Multiplexers

## \_ Ordering Information (continued)

PART	TEMP. RANGE	PIN-PACKAGE
MAX4519CPD	0°C to +70°C	14 Plastic DIP
MAX4519CSD	0°C to +70°C	14 SO
MAX4519CEE	0°C to +70°C	16 QSOP
MAX4519C/D	0°C to +70°C	Dice*
MAX4519EPD	0°C to +70°C	14 Plastic DIP
MAX4519ESD	-40°C to +85°C	14 SO
MAX4519EEE	-40°C to +85°C	16 QSOP
MAX4519MJD	-55°C to +125°C	14 CERDIP**

\* Contact factory for dice specifications.

\*\* Contact factory for package availability.

## Chip Topographies

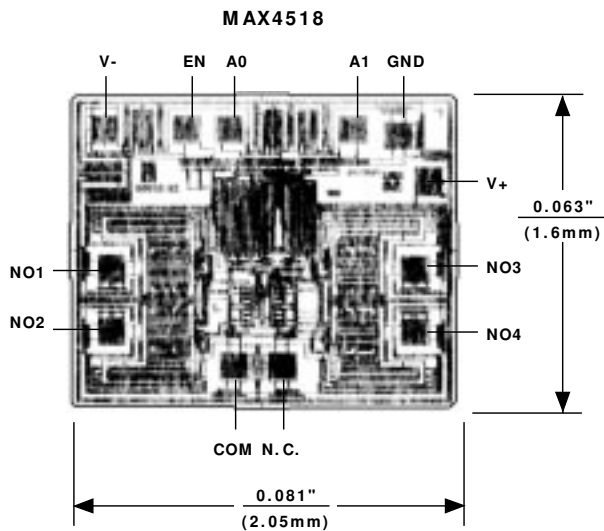

TRANSISTOR COUNT: 86  
SUBSTRATE CONNECTED TO V+

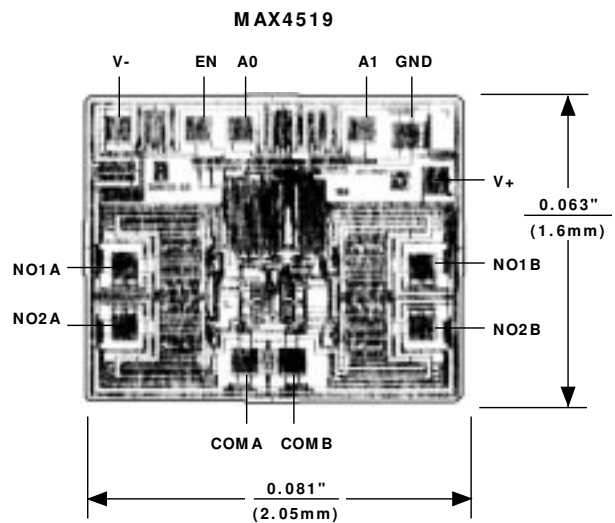

TRANSISTOR COUNT: 86  
SUBSTRATE CONNECTED TO V+

Maxim cannot assume responsibility for use of any circuitry other than circuitry entirely embodied in a Maxim product. No circuit patent licenses are implied. Maxim reserves the right to change the circuitry and specifications without notice at any time.

12 \_\_\_\_\_ Maxim Integrated Products, 120 San Gabriel Drive, Sunnyvale, CA 94086 408-737-7600