

FCI CONFIDENTIAL

FCI

FCIconnect.com

This document is the property of and embodies CONFIDENTIAL and PROPRIETARY information of FCI. No part of the information shown on this document may be used in any way or disclosed to others without the written consent of FCI.  
Copyright FCI.

PRODUCT No.  
10079074-001LF

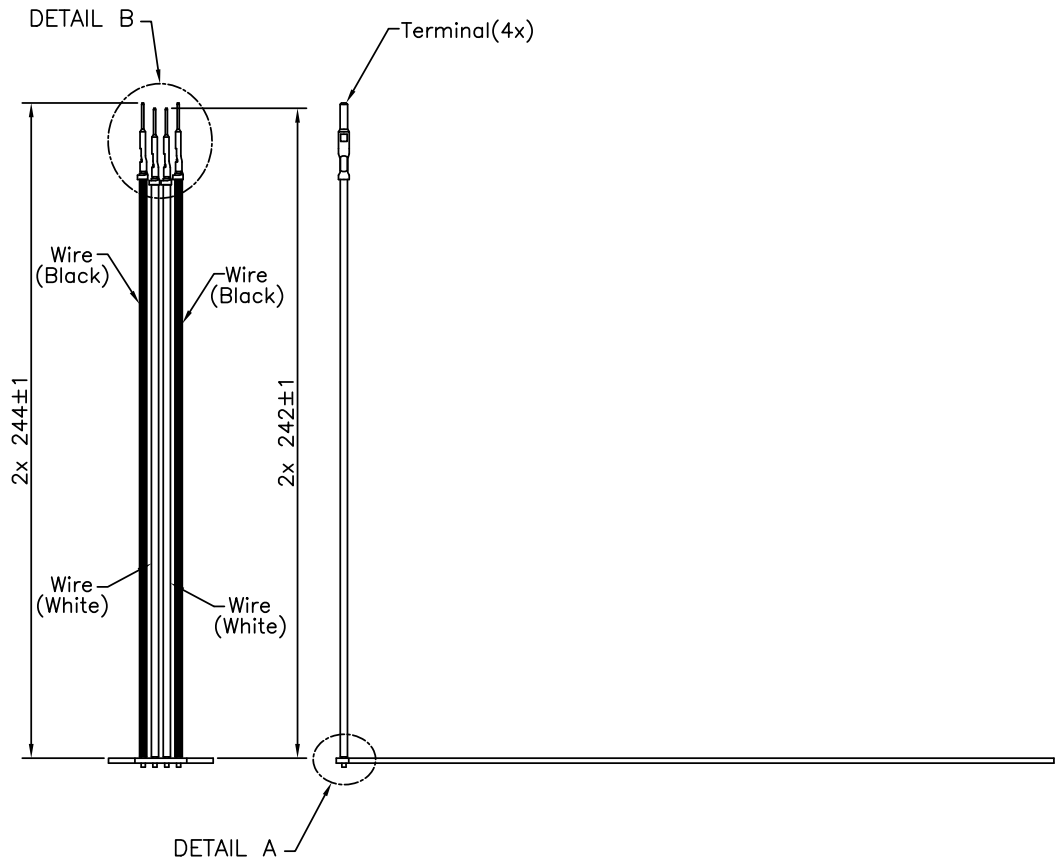

- NOTES:
- 100% CONTINUITY TEST FOR OPEN,SHORTING,ETC..
  - WIRES SOLDERED DIRECTLY TO PCB.
  - MAKE SURE THE CONTACT ORIENTATION, SEE DETAIL B.
  - OUTER CABLES HAVE TO BE 2MM LONGER THAN INNER CABLES.
  - PCB THICKNESS 1.8MM(REF).
  - ROHS COMPLIANCE.

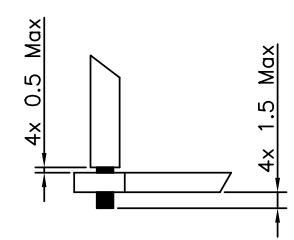

DETAIL A  $\triangle 2$   
SCALE 4:1

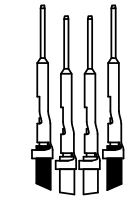

DETAIL B  $\triangle 3$   
SCALE 2:1

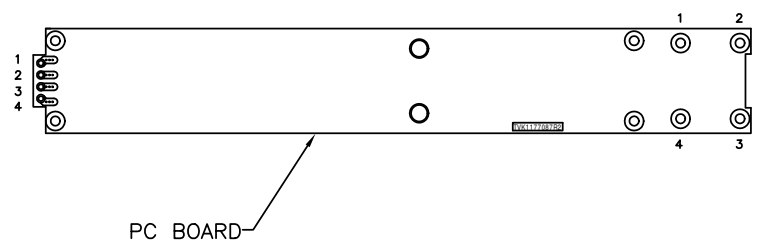

|                |              |
|----------------|--------------|
| FCI P/N        | ERICSSON P/N |
| 10079074-001LF | SXK1115156/1 |

|                   |               |                                       |         |                   |  |            |  |                          |  |
|-------------------|---------------|---------------------------------------|---------|-------------------|--|------------|--|--------------------------|--|
| mat'l. code       |               | surface                               |         | tolerance         |  | projection |  | product family           |  |
|                   |               | ISO 1302                              |         | ISO 406 ISO 1101  |  |            |  | ERICSSON Power PBA       |  |
| tr ecn no dr date |               | tolerances unless otherwise specified |         | title             |  |            |  |                          |  |
| A                 | N07-0207      | ST                                    | 8/30/07 | angles            |  | linear     |  | MM                       |  |
| B                 | 00-01-11-03-1 | ST                                    | 4/8/13  | ±2'               |  | ±1.0       |  | scale                    |  |
|                   |               |                                       |         | dr Sunny Tsai     |  | 10JUL07    |  | dwg no sheet 1 of 1 size |  |
|                   |               |                                       |         | engr Sunny Tsai   |  | 10JUL07    |  | 10079074 A4              |  |
|                   |               |                                       |         | chr Jackson Wang  |  | 10JUL07    |  | type CUSTOMER Drawing    |  |
|                   |               |                                       |         | appd Jackson Wang |  | 10JUL07    |  |                          |  |
| sheet index       | revision      | B                                     |         |                   |  |            |  |                          |  |
|                   | sheet         | 1                                     |         |                   |  |            |  |                          |  |