

FEATURES

- 400 MSPS internal DDS clock speed
- 48-bit frequency tuning word
- 14-bit programmable phase offset
- Integrated 14-bit DAC
 - Excellent dynamic performance
 - Phase noise ≤ 135 dBc/Hz @ 1 KHz offset
 - 80 dB SFDR @ 160 MHz (± 100 KHz offset I_{OUT})
- 25 Mb/s write-speed serial I/O control
- 200 MHz phase frequency detector inputs
- 655 MHz programmable input dividers for the phase frequency detector ($\div M, \div N$) { $M, N = 1..16$ } (bypassable)
- Programmable RF divider ($\div R$) { $R = 1, 2, 4, 8$ } (bypassable)
- 8 phase/frequency profiles
- 1.8 V supply for device operation

- 3.3 V supply for I/O and charge pump
- Software controlled power-down
- 48-lead LFCSP package
- Automatic linear frequency sweeping capability (in DDS)
- Programmable charge pump current (up to 4 mA)
- Phase modulation capability
- Multichip synchronization
- Dual-mode PLL lock detect
- 655 MHz CML-mode PECL-compliant driver

APPLICATIONS

- Agile LO frequency synthesis
- FM chirp source for radar and scanning systems
- Automotive radars
- Test and measurement equipment
- Acousto-optic device drivers

FUNCTIONAL BLOCK DIAGRAM

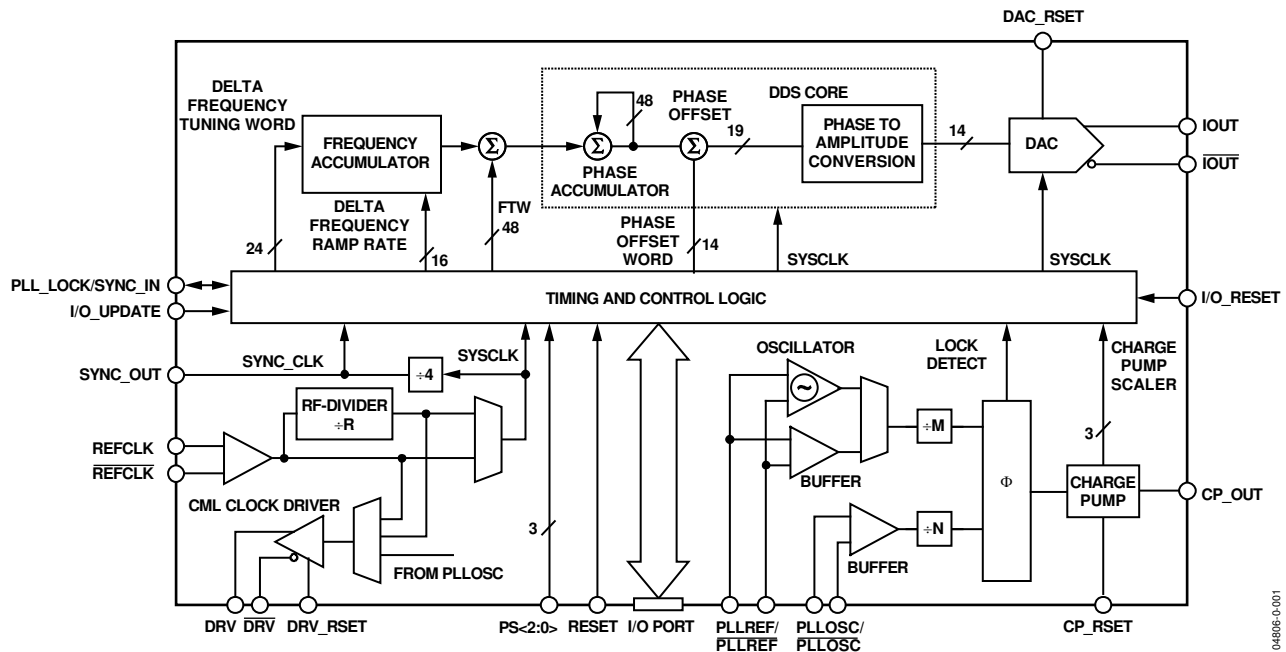

Figure 1.

Rev. B

Information furnished by Analog Devices is believed to be accurate and reliable. However, no responsibility is assumed by Analog Devices for its use, nor for any infringements of patents or other rights of third parties that may result from its use. Specifications subject to change without notice. No license is granted by implication or otherwise under any patent or patent rights of Analog Devices. Trademarks and registered trademarks are the property of their respective owners.

TABLE OF CONTENTS

Product Overview.....	3	CML Driver.....	19
Specifications	4	Modes of Operation.....	20
Loop Measurement Conditions	9	DDS Modes of Operation	20
Absolute Maximum Ratings	10	Synchronization Modes for Multiple Devices	20
ESD Caution.....	10	Serial Port Operation.....	22
Pin Configuration and Function Descriptions	11	Instruction Byte.....	23
Typical Performance Characteristics.....	13	Serial Interface Port Pin Description	23
Typical Application Circuits.....	16	MSB/LSB Transfers.....	23
Application Circuit Explanations	17	Register Map and Description.....	24
General Description.....	18	Control Function Register Descriptions.....	27
DDS Core	18	Outline Dimensions.....	32
PLL Circuitry	18	Ordering Guide	32

REVISION HISTORY

8/2020—Rev. A to Rev. B

Changes to Figure 3.....	11
Updated Outline Dimensions.....	32
Changes to Ordering Guide.....	32

9/2004—Rev. 0 to Rev. A

Changes to the Pin Configuration	11
Changes to the Pin Function Descriptions.....	12
Changes to Table 5	24
Changes to CFR2<15:12> PLLREF Divider Control Bits (÷N)	31
Changes to CFR2<11:8> PLLREF Divider Control Bits (÷M).....	31
Changes to Ordering Guide.....	32

7/2004—Revision: Initial Version

PRODUCT OVERVIEW

The AD9956 is Analog Devices' newest *AgileRF* synthesizer. The device is comprised of DDS and PLL circuitry. The DDS features a 14-bit DAC operating at up to 400 MSPS and a 48-bit frequency tuning word (FTW). The PLL circuitry includes a phase frequency detector with scaleable 200 MHz inputs (divider inputs operate up to 655 MHz) and digital control over the charge pump current. The device also includes a 655 MHz CML-mode PECL-compliant driver with programmable slew rates. The AD9956 uses advanced DDS technology, an internal high speed, high performance DAC, and an advanced phase frequency detector/charge pump combination, which, when used with an external VCO, enables the synthesis of digitally programmable, frequency-agile analog output sinusoidal waveforms up to 2.7 GHz. The AD9956 is designed to provide fast frequency hopping and fine tuning resolution (48-bit frequency tuning word). Information is loaded into the AD9956 via a serial I/O port that has a device write-speed of 25 Mb/s. The AD9956 DDS block also supports a user-defined linear sweep mode of operation.

The AD9956 is specified to operate over the extended automotive range of -40°C to $+125^{\circ}\text{C}$.

SPECIFICATIONS

AVDD = DVDD = 1.8 V ± 5%; DVDD_I/O = CP_VDD = 3.3 V ± 5% (@ T_A = 25°C) DAC_RSET = 3.92 kΩ, CP_RSET = 3.09 kΩ, DRV_RSET = 4.02 kΩ, unless otherwise noted.

Table 1.

Parameter	Min	Typ	Max	Unit	Test Conditions/Comments
RF DIVIDER (REFCLK) INPUT SECTION (÷R)					
RF Divider Input Range	1		2700	MHz	DDS SYSClk not to exceed 400 MSPS Single-ended, into a 50 Ω load ¹
Input Capacitance (DC)		3		pF	
Input Impedance (DC)		1500		Ω	
Input Duty Cycle	42	50	58	%	
Input Power/Sensitivity	-10		+4	dBm	
Input Voltage Level	350		1000	mV p-p	
PHASE FREQUENCY DETECTOR/CHARGE PUMP					
PLLREF Input					
Input Frequency ²					
÷M Set to Divide by at Least 4			655	MHz	
÷M Bypassed			200	MHz	
Input Voltage Levels	200	450	600	mV p-p	
Input Capacitance			10	pF	
Input Resistance		1500		Ω	
PLLOSC Input					
Input Frequency					
÷N Set to Divide by at Least 4			655	MHz	
÷N Bypassed			200	MHz	
Input Voltage Levels	200	450	600	mV p-p	
Input Capacitance			10	pF	
Input Resistance		1500		Ω	
Charge Pump Source/Sink Maximum Current			4	mA	
Charge Pump Source/Sink Accuracy	-15		+5	%	
Charge Pump Source/Sink Matching	-5		+5	%	
Charge Pump Output Compliance Range ³	0.5		CP_VDD - 0.5	V	
PLL_LOCK Drive Strength		2		mA	
PHASE FREQUENCY DETECTOR NOISE FLOOR					
@ 50 kHz PFD Frequency		149		dBc/Hz	
@ 2 MHz PFD Frequency		133		dBc/Hz	
@ 100 MHz PFD Frequency		116		dBc/Hz	
@ 200 MHz PFD Frequency		113		dBc/Hz	
CML OUTPUT DRIVER (DRV)					
Differential Output Voltage Swing ⁴		720		mV	50 Ω load to supply, both lines
Maximum Toggle Rate	655			MHz	
Common-Mode Output Voltage		1.75		V	
Output Duty Cycle	42	50	58	%	
Output Current					
Continuous ⁵		7.2		mA	
Rising Edge Surge		20.9		mA	
Falling Edge Surge		13.5		mA	
Output Rise Time		250		ps	100 Ω terminated, 5 pF load

Parameter	Min	Typ	Max	Unit	Test Conditions/Comments
LOGIC INPUTS (SDI/O, I/O_RESET, RESET, I/O_UPDATE, PS0 to PS2, SYNC_IN)					
V _{IH} , Input High Voltage	2.0			V	
V _{IL} , Input Low Voltage			0.8	V	
I _{INH} , I _{INL} Input Current		±1	±5	μA	
C _{IN} , Maximum Input Capacitance		3		pF	
LOGIC OUTPUTS (SDO, SYNC_OUT, PLL_LOCK) ⁶					
V _{OH} , Output High Voltage	2.7			V	
V _{OL} , Output Low Voltage			0.4	V	
I _{OH}	100			μA	
I _{OL}	100			μA	
POWER CONSUMPTION					
Total Power Consumed, All Functions On			400	mW	
I _{AVDD}			85	mA	
I _{DVDD}			45	mA	
I _{DVDD_I/O}			20	mA	
I _{CP_VDD}			15	mA	
Power-Down Mode		80		mW	
WAKE-UP TIME (from Power-Down Mode)					
Digital Power-Down (CFR1<7>)		12		ns	
DAC Power-Down (CFR2<39>)		7		μs	
RF Divider Power-Down (CFR2<23>)		400		ns	
Clock Driver Power-Down (CFR2<20>)		6		μs	
Charge Pump Full Power-Down (CFR2<4>)		10		μs	
Charge Pump Quick Power-Down (CFR2<3>)		150		ns	
DAC OUTPUT CHARACTERISTICS					
Resolution		14		Bits	
Full-Scale Output Current		10	15	mA	
Gain Error	-10		+10	% FS	
Output Offset			0.6	μA	
Output Capacitance		5		pF	
Voltage Compliance Range	AVDD - 0.50		AVDD + 0.50	V	
Wideband SFDR (DC to Nyquist)					
10 MHz Analog Out		-64		dBc	
40 MHz Analog Out		-62		dBc	
80 MHz Analog Out		-60		dBc	
120 MHz Analog Out		-55		dBc	
160 MHz Analog Out		-55		dBc	
Narrowband SFDR					
10 MHz Analog Out (±1 MHz)		-89		dBc	
10 MHz Analog Out (±250 kHz)		-91		dBc	
10 MHz Analog Out (±50 kHz)		-93		dBc	
40 MHz Analog Out (±1 MHz)		-87		dBc	
40 MHz Analog Out (±250 kHz)		-89		dBc	
40 MHz Analog Out (±50 kHz)		-91		dBc	
80 MHz Analog Out (±1 MHz)		-85		dBc	
80 MHz Analog Out (±250 kHz)		-87		dBc	
80 MHz Analog Out (±50 kHz)		-89		dBc	
120 MHz Analog Out (±1 MHz)		-83		dBc	
120 MHz Analog Out (±250 kHz)		-85		dBc	
120 MHz Analog Out (±50 kHz)		-87		dBc	

AD9956

Parameter	Min	Typ	Max	Unit	Test Conditions/Comments
160 MHz Analog Out (± 1 MHz)		-81		dBc	
160 MHz Analog Out (± 250 kHz)		-83		dBc	
160 MHz Analog Out (± 50 kHz)		-85		dBc	
DAC Residual Phase Noise					
19.7 MHz F _{OUT}					
@ 10 Hz Offset		125		dBc/Hz	
@ 100 Hz Offset		135		dBc/Hz	
@ 1 kHz Offset		143		dBc/Hz	
@ 10 kHz Offset		152		dBc/Hz	
@ 100 kHz Offset		158		dBc/Hz	
>1 MHz Offset		163		dBc/Hz	
51.84 MHz F _{OUT}					
@ 10 Hz Offset		119		dBc/Hz	
@ 100 Hz Offset		125		dBc/Hz	
@ 1 kHz Offset		132		dBc/Hz	
@ 10 kHz Offset		142		dBc/Hz	
@ 100 kHz Offset		150		dBc/Hz	
>1 MHz Offset		155		dBc/Hz	
105.3 MHz Analog Out					
@ 10 Hz Offset		105		dBc/Hz	
@ 100 Hz Offset		115		dBc/Hz	
@ 1 kHz Offset		122		dBc/Hz	
@ 10 kHz Offset		131		dBc/Hz	
@ 100 kHz Offset		139		dBc/Hz	
>1 MHz Offset		142		dBc/Hz	
155.52 MHz Analog Out					
@ 10 Hz Offset		105		dBc/Hz	
@ 100 Hz Offset		110		dBc/Hz	
@ 1 kHz Offset		119		dBc/Hz	
@ 10 kHz Offset		127		dBc/Hz	
@ 100 kHz Offset		135		dBc/Hz	
>1 MHz Offset		142		dBc/Hz	
CRYSTAL OSCILLATOR (ON PLLREF INPUT)					
Operating Range	20	25	30	MHz	
Residual Phase Noise (@ 25 MHz)					
@ 10 Hz Offset		95		dBc/Hz	
@ 100 Hz Offset		120		dBc/Hz	
@ 1 kHz Offset		137		dBc/Hz	
@ 10 kHz Offset		156		dBc/Hz	
@ 100 kHz Offset		164		dBc/Hz	
>1 MHz Offset		170		dBc/Hz	
DIGITAL TIMING SPECIFICATIONS					
\overline{CS} to SCLK Setup Time TPRE	6			ns	
Period of SCLK (Write Speed) TSCLKW	40			ns	
Period of SCLK (Read Speed) TSCLKR		400		ns	
Serial Data Setup Time TDSU	6.5			ns	
Serial Data Hold Time TDHLD	0			ns	
TDV Data Valid Time TDV	40			ns	
I/O Update to SYNC_CLK Setup Time TUD	7			ns	
PS<2:0> to SYNC_CLK Setup Time TPS	7			ns	

Parameter	Min	Typ	Max	Unit	Test Conditions/Comments
Latencies/Pipeline Delays ⁷					
I/O Update to DAC Frequency Change		33		SYSCLK Cycles	
I/O Update to DAC Phase Change		33		SYSCLK Cycles	
PS<2:0> to DAC Frequency Change		29		SYSCLK Cycles	
PS<2:0> to DAC Phase Change		29		SYSCLK Cycles	
I/O Update to CP_OUT Scaler Change		4		SYSCLK Cycles	
I/O Update to Frequency Accumulator Step Size Change		4		SYSCLK Cycles	
I/O Update to Frequency Accumulator Ramp Rate Change		4		SYSCLK Cycles	
RF DIVIDER/CML DRIVER EQUIVALENT INTRINSIC TIME JITTER					
$F_{IN} = 414.72 \text{ MHz}$, $F_{OUT} = 51.84 \text{ MHz}$ BW = 12 kHz → 400 kHz		136		f_s rms	OC1, RF Divider R = 8
$F_{IN} = 1244.16 \text{ MHz}$, $F_{OUT} = 155.52 \text{ MHz}$ BW = 12 kHz → 1.3 MHz		101		f_s rms	OC3, RF Divider R = 8
$F_{IN} = 2488.32 \text{ MHz}$, $F_{OUT} = 622.08 \text{ MHz}$ BW = 12 kHz → 5 MHz		108		f_s rms	OC12, RF Divider R = 4
RF DIVIDER/CML DRIVER RESIDUAL PHASE NOISE					
$F_{IN} = 157.6 \text{ MHz}$, $F_{OUT} = 19.7 \text{ MHz}$					RF Divider R = 8
@ 10 Hz		-115		dBc/Hz	
@ 100 Hz		-126		dBc/Hz	
@ 1 kHz		-134		dBc/Hz	
@ 10 kHz		-143		dBc/Hz	
@ 100 kHz		-150		dBc/Hz	
> 1 MHz		-151		dBc/Hz	
$F_{IN} = 1240 \text{ MHz}$, $F_{OUT} = 155 \text{ MHz}$					RF Divider R = 8
@ 10 Hz		-111		dBc/Hz	
@ 100 Hz		-122		dBc/Hz	
@ 1 kHz		-129		dBc/Hz	
@ 10 kHz		-138		dBc/Hz	
@ 100 kHz		-146		dBc/Hz	
@ 1 MHz		-150		dBc/Hz	
>3 MHz		-153		dBc/Hz	
$F_{IN} = 2488 \text{ MHz}$, $F_{OUT} = 622 \text{ MHz}$					RF Divider R = 4
@ 10 Hz		-97		dBc/Hz	
@ 100 Hz		-110		dBc/Hz	
@ 1 kHz		-120		dBc/Hz	
@ 10 kHz		-126		dBc/Hz	
@ 100 kHz		-136		dBc/Hz	
@ 1 MHz		-141		dBc/Hz	
>3 MHz		-144		dBc/Hz	
TOTAL SYSTEM TIME JITTER FOR 622 MHz CLOCK					See the Loop Measurement Conditions section
12 kHz to 5 MHz Bandwidth		0.7		ps rms	

AD9956

Parameter	Min	Typ	Max	Unit	Test Conditions/Comments
TOTAL SYSTEM JITTER AND PHASE NOISE FOR 105.33 MHz ADC CLOCK GENERATION CIRCUIT					See the Loop Measurement Conditions section
Converter Limiting Jitter		0.53		ps rms	
Resultant SNR		67		dB	
Phase Noise of Fundamental					
@ 10 Hz Offset		-75		dBc/Hz	
@ 100 Hz Offset		-87		dBc/Hz	
@ 1 kHz Offset		-93		dBc/Hz	
@ 10 kHz Offset		-105		dBc/Hz	
@ 100 kHz Offset		-145		dBc/Hz	
@ ≥1 MHz Offset		-152		dBc/Hz	

¹ The input impedance of the REFCLK input is 1500 Ω. However, in order to provide matching on the clock line, an external 50 Ω load is used.

² Driving the PLLREF input buffer, the crystal oscillator section of this input stage performs up to only 30 MHz.

³ The charge pump output compliance range is functionally 0.2 V to (CP_VDD – 0.2 V). The value listed here is the compliance range for 5% matching.

⁴ Measured as peak-to-peak from DRV to $\overline{\text{DRV}}$.

⁵ For a 4.02 kΩ resistor from DRV_RSET to GND.

⁶ Assumes a 1 mA load.

⁷ I/O_UPDATE/PS<2:0> are detected by the AD9956 synchronous to the rising edge of SYNC_CLK. Each latency measurement is from the first SYNC_CLK rising edge after the I/O_UPDATE/PS<2:0> state change.

LOOP MEASUREMENT CONDITIONS**622 MHz OC-12 Clock**

VCO = Sirenza 190-640T

Reference = Wenzel 500-10116 (30.3 MHz)

Loop Filter = 10 kHz BW, 60° Phase Margin

C1 = 170 nF, R1 = 14.4 Ω , C2 = 5.11 μ F, R2 = 89.3 Ω ,
C3 OmittedCP_OUT = 4 mA (Scaler = $\times 8$) $\div R = 2$, $\div M = 1$, $\div N = 1$ **105 MHz Converter Clock**

VCO = Sirenza 190-845T

Reference = Wenzel 500-10116 (30.3 MHz)

Loop Filter = 10 kHz BW, 45° Phase Margin

C1 = 117 nF, R1 = 28 Ω , C2 = 1.6 μ F, R2 = 57.1 Ω , C3 = 53.4 nFCP_OUT = 4 mA (Scaler = $\times 8$) $\div R = 8$, $\div M = 1$, $\div N = 1$ 

Figure 2. Generic Loop Filter

0480E-0-033

ABSOLUTE MAXIMUM RATINGS

Table 2.

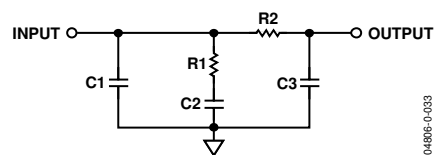
Parameter	Rating
Analog Supply Voltage (AVDD)	2 V
Digital Supply Voltage (DVDD)	2 V
Digital I/O Supply Voltage (DVDD_I/O)	3.6 V
Charge Pump Supply Voltage (CPVDD)	3.6 V
Maximum Digital Input Voltage	-0.5 V to DVDD_I/O + 0.5 V
Storage Temperature	-65°C to +150°C
Operating Temperature Range	-40°C to +125°C
Lead Temperature Range (Soldering 10 sec)	300°C
Junction Temperature	150°C
Thermal Resistance (θ_{JA})	26°C/W

Stresses above those listed under Absolute Maximum Ratings may cause permanent damage to the device. This is a stress rating only; functional operation of the device at these or any other conditions above those indicated in the operational section of this specification is not implied. Exposure to absolute maximum rating conditions for extended periods may affect device reliability.

ESD CAUTION

ESD (electrostatic discharge) sensitive device. Electrostatic charges as high as 4000 V readily accumulate on the human body and test equipment and can discharge without detection. Although this product features proprietary ESD protection circuitry, permanent damage may occur on devices subjected to high energy electrostatic discharges. Therefore, proper ESD precautions are recommended to avoid performance degradation or loss of functionality.



PIN CONFIGURATION AND FUNCTION DESCRIPTIONS

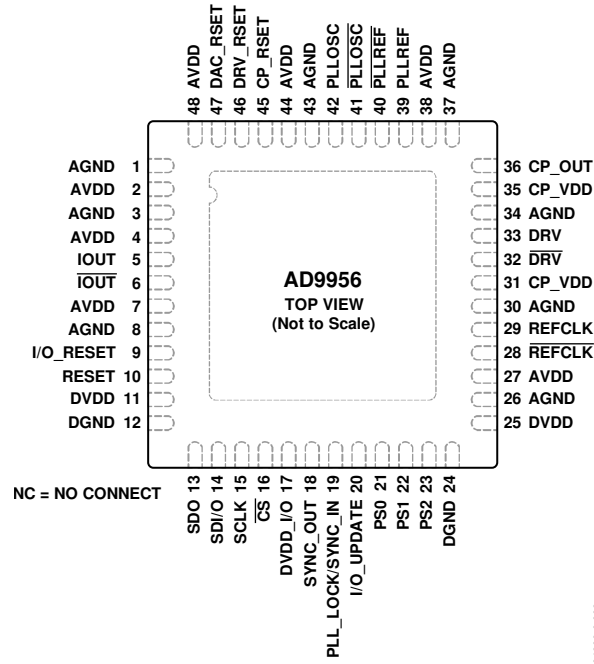

Figure 3. 48-Lead LFCSP Pin Configuration

Note that the exposed paddle on this package is an electrical connection (Pin 49) as well as a thermal enhancement. For the device to function properly, the paddle **MUST** be attached to analog ground.

Table 3. 48-Lead LFCSP Pin Function Description

Pin No.	Mnemonic	Description
1, 3, 8, 26, 30, 34, 37, 43, 49	AGND	Analog Ground.
2, 4, 7, 27, 38, 44, 48	AVDD	Analog Core Supply (1.8 V).
5	IOUT	DAC Analog Output.
6	$\overline{\text{IOUT}}$	DAC Analog Complementary Output.
9	I/O_RESET	Resets the serial port when synchronization is lost in communications but does not reset the device itself (ACTIVE HIGH). When not being used, this pin should be forced low, because it floats to the threshold value.
10	RESET	Master RESET. Clears all accumulators and returns all registers to their default values (ACTIVE HIGH).
11, 25	DVDD	Digital Core Supply (1.8 V).
12, 24	DGND	Digital Ground.
13	SDO	Serial Data Output. Used only when device is programmed for 3-wire serial data mode.
14	SDI/O	Serial Data I/O. When the part is programmed for 3-wire serial data mode, this is input only; in 2-wire mode, it serves as both the input and output.
15	SCLK	Serial Data Clock. Provides the clock signal for the serial data port.
16	$\overline{\text{CS}}$	Active Low Signal That Enables Shared Serial Busses. When brought high, the serial port ignores the serial data clocks.
17	DVDD_I/O	Digital Interface Supply (3.3 V).
18	SYNC_OUT	Synchronization Clock Output.
19	PLL_LOCK/SYNC_IN	Bidirectional Dual Function Pin. Depending on device programming, it is either the DDS' synchronization input (allows alignment of multiple subclocks) or the PLL lock detect output signal.
20	I/O_UPDATE	This input pin, when set high, transfers the data from the I/O buffers to the internal registers on the rising edge of the internal SYNC_CLK, which can be observed on SYNC_OUT.
21 to 23	PS0 to PS2	Profile Select Pins. Specify one of eight frequency tuning word/phase offset word profiles. In linear sweep mode, PS0 determines the state of the sweep. In linear sweep no dwell mode, PS0 is a trigger that initiates the sweep. PS1 and PS2 have no function during linear sweep mode or linear sweep no dwell mode.
28	REFCLK	RF Divider and DDS REFCLK Complementary Input.
29	REFCLK	RF Divider and DDS REFCLK Input.
32	$\overline{\text{DRV}}$	CML Driver Complementary Output.
33	DRV	CML Driver Output.
31, 35	CP_VDD	Charge Pump Supply Pin (3.3 V). To minimize noise on the charge pump, isolate this supply from DVDD_I/O.
36	CP_OUT	Charge Pump Output.
39	PLLREF	Phase Frequency Detector Reference Input.
40	$\overline{\text{PLLREF}}$	Phase Frequency Detector Reference Complementary Input.
41	$\overline{\text{PLLOSC}}$	Phase Frequency Detector Oscillator (Feedback) Complementary Input.
42	PLLOSC	Phase Frequency Detector Oscillator (Feedback) Input.
45	CP_RSET	Charge Pump Current Set (Program Charge Pump Current with a Resistor to AGND).
46	DRV_RSET	CML Driver Output Current Set (Program CML Output Current with a Resistor to AGND).
47	DAC_RSET	DAC Output Current Set (Program DAC Output Current with a Resistor to AGND).

Note that the exposed paddle on this package is an electrical connection (Pin 49) as well as a thermal enhancement. In order for the device to function properly, the paddle MUST be attached to analog ground.

TYPICAL PERFORMANCE CHARACTERISTICS

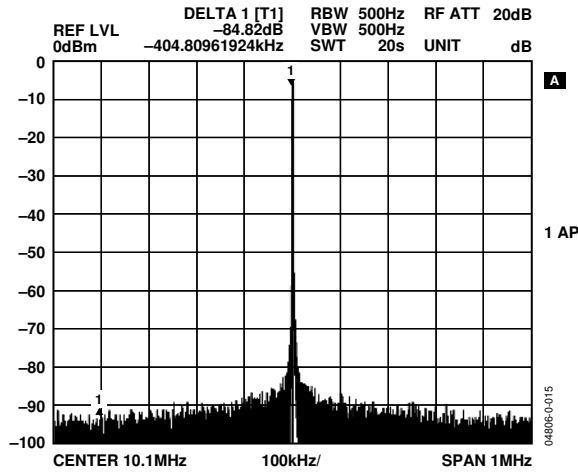

Figure 4. AD9956 DAC Performance: 400 MSPS Clock, 10 MHz F_{OUT} , 1 MHz Span

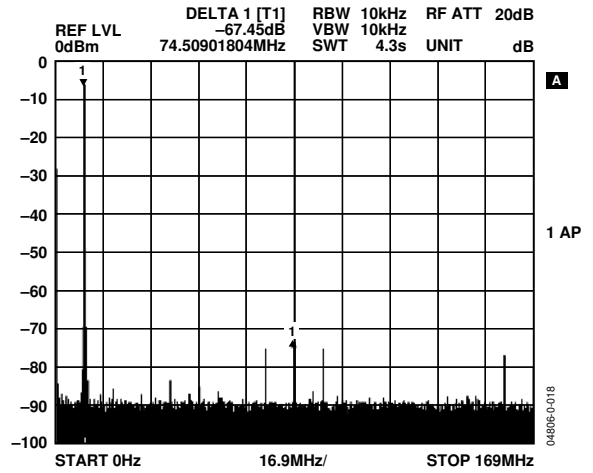

Figure 7. AD9956 DAC Performance: 400 MSPS Clock, 10 MHz F_{OUT} , 200 MHz Span

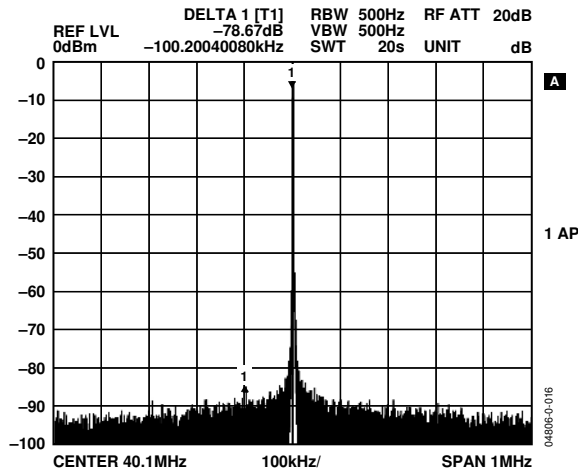

Figure 5. AD9956 DAC Performance: 400 MSPS Clock, 40 MHz F_{OUT} , 1 MHz Span

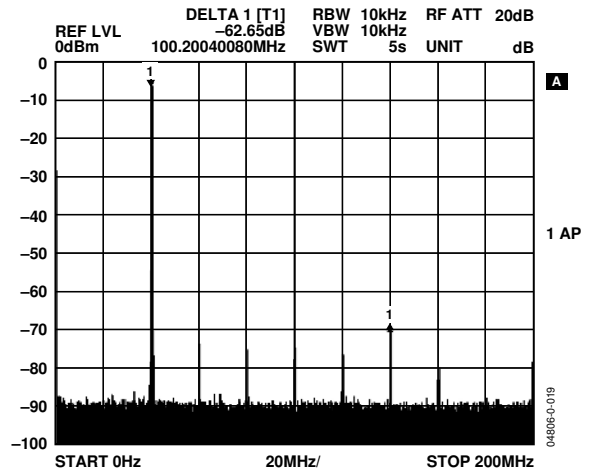

Figure 8. AD9956 DAC Performance: 400 MSPS Clock, 40 MHz F_{OUT} , 200 MHz Span

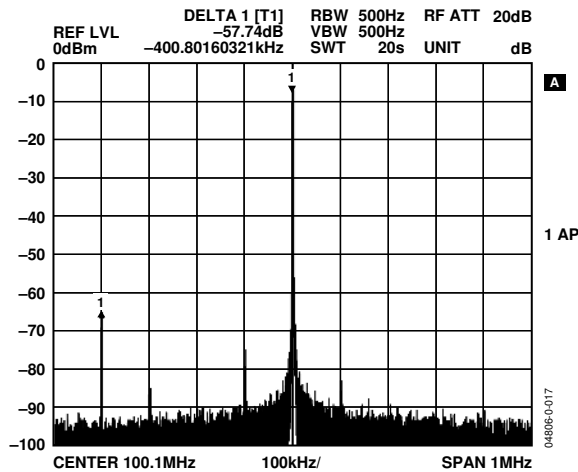

Figure 6. AD9956 DAC Performance: 400 MSPS Clock, 100 MHz F_{OUT} , 1 MHz Span

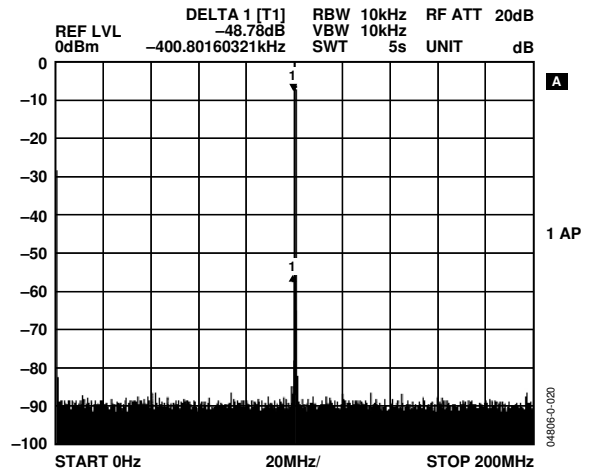

Figure 9. AD9956 DAC Performance: 400 MSPS Clock, 100 MHz F_{OUT} , 200 MHz Span

AD9956

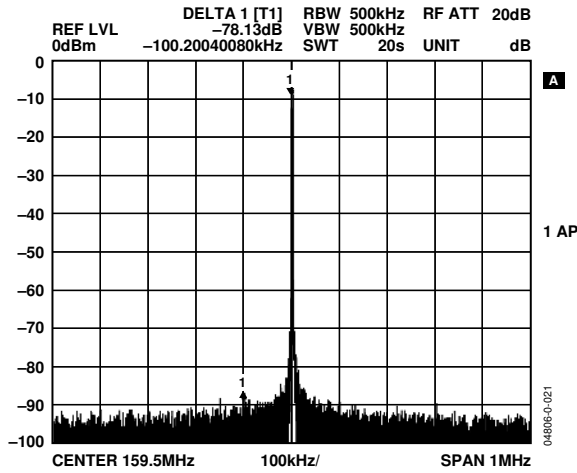

Figure 10. AD9956 DAC Performance: 400 MSPS Clock, 160 MHz F_{OUT} , 1 MHz Span

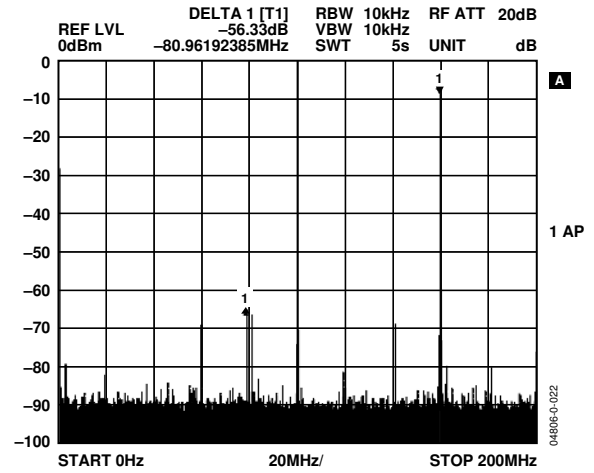

Figure 13. AD9956 DAC Performance: 400 MSPS Clock, 160 MHz F_{OUT} , 200 MHz Span

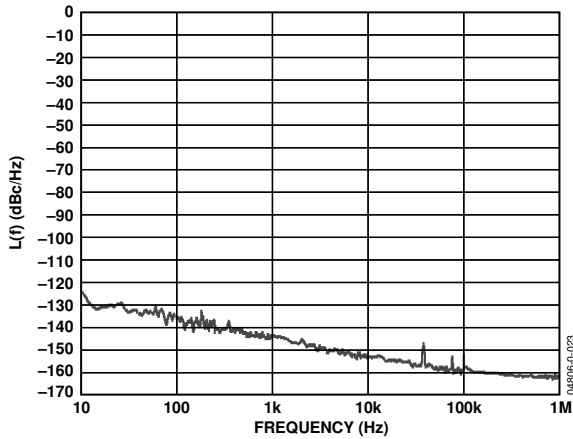

Figure 11. AD9956 DDS/DAC Residual Phase Noise 400 MHz Clock, 10 MHz Output

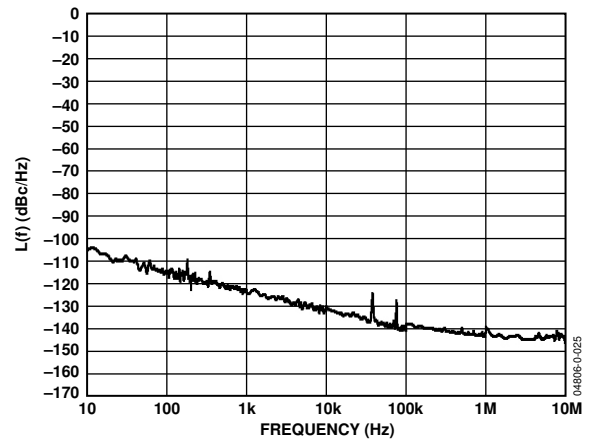

Figure 14. AD9956 DDS/DAC Residual Phase Noise 400 MHz Clock, 103 MHz Output

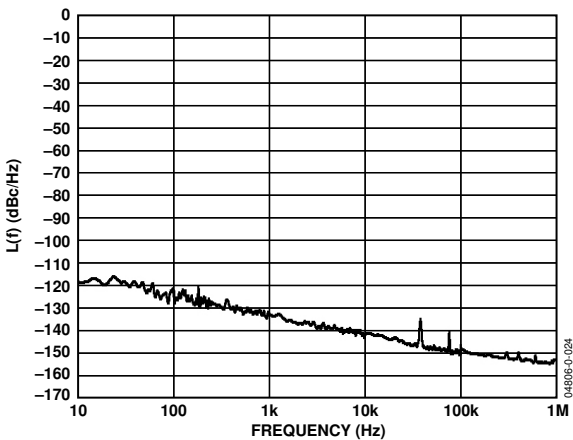

Figure 12. AD9956 DDS/DAC Residual Phase Noise 400 MHz Clock, 40 MHz Output

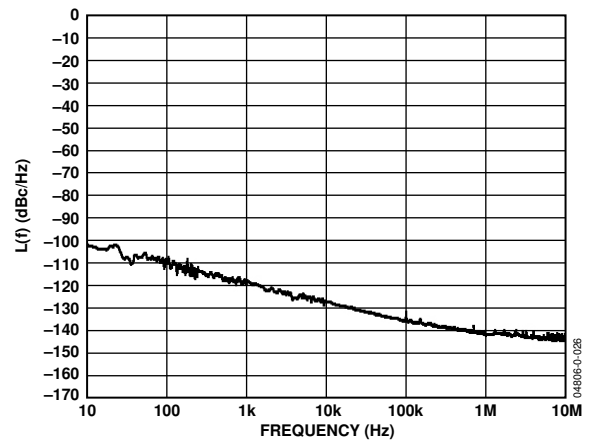

Figure 15. AD9956 DDS/DAC Residual Phase Noise 400 MHz Clock, 159 MHz Output

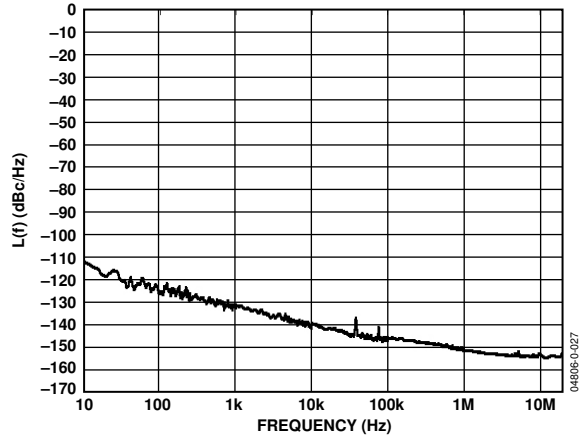

Figure 16. RF Divider and CML Driver Residual Phase Noise (840 MHz In, 105 MHz Out)

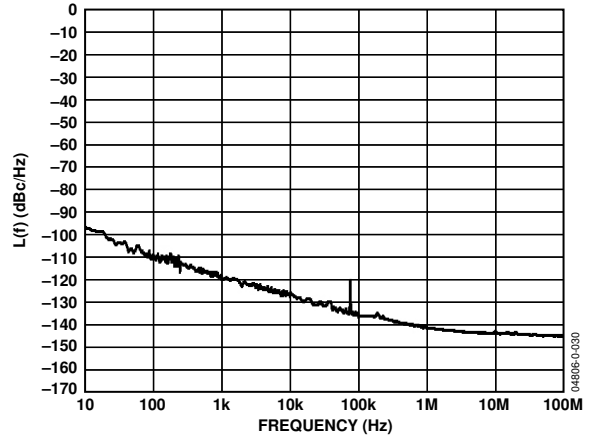

Figure 19. RF Divider and CML Driver Residual Phase Noise (2488 MHz In, 622 MHz Out)

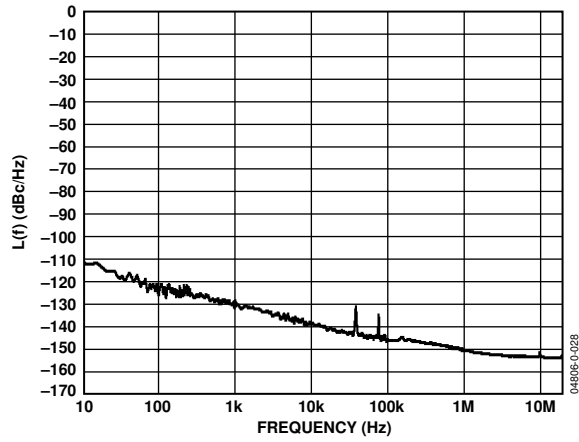

Figure 17. RF Divider and CML Driver Residual Phase Noise (1240 MHz In, 155 MHz Out)

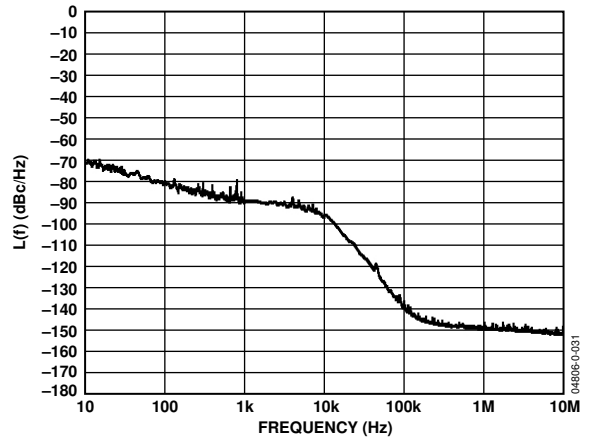

Figure 20. Total System Phase Noise for 105 MHz Converter Clock

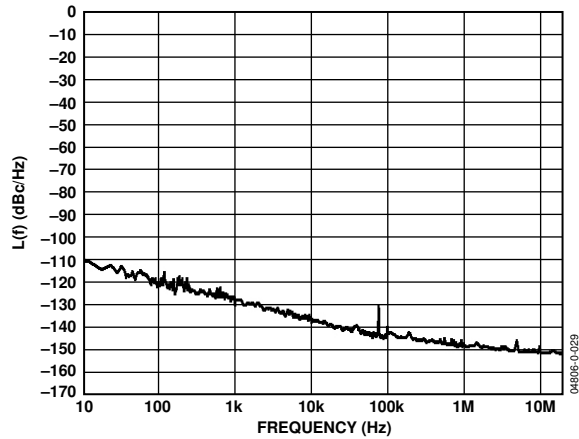

Figure 18. RF Divider and CML Driver Residual Phase Noise (1680 MHz In, 210 MHz Out)

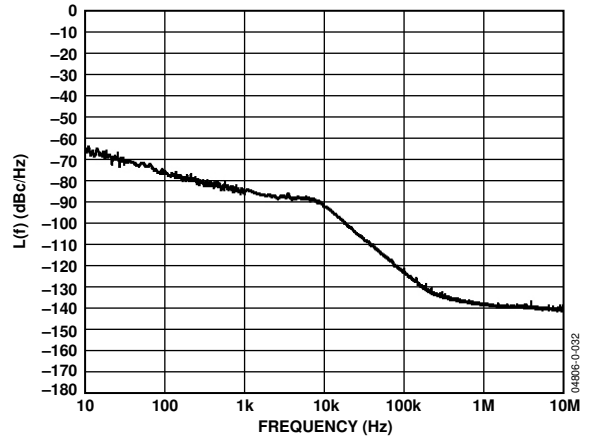

Figure 21. Total System Phase Noise for 622 MHz OC-12 Clock

TYPICAL APPLICATION CIRCUITS

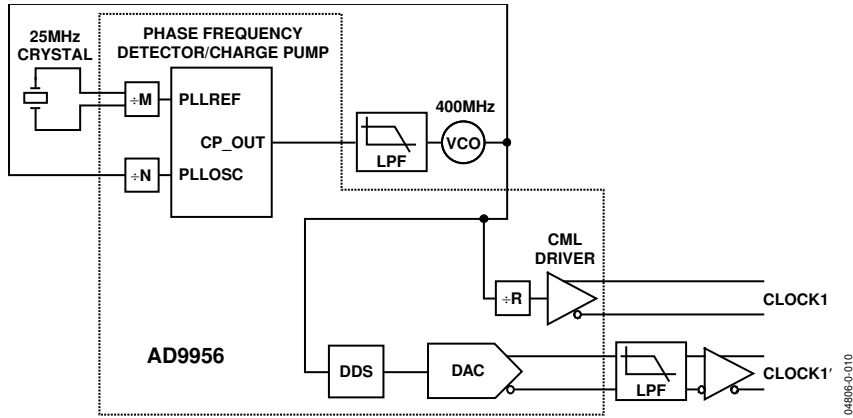

Figure 22. Dual-Clock Configuration

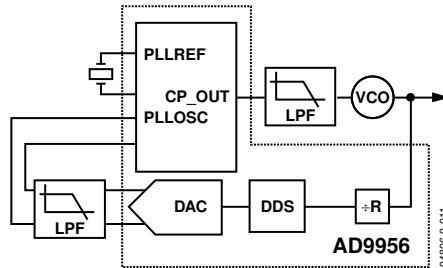

Figure 23. Fractional-Divider Loop

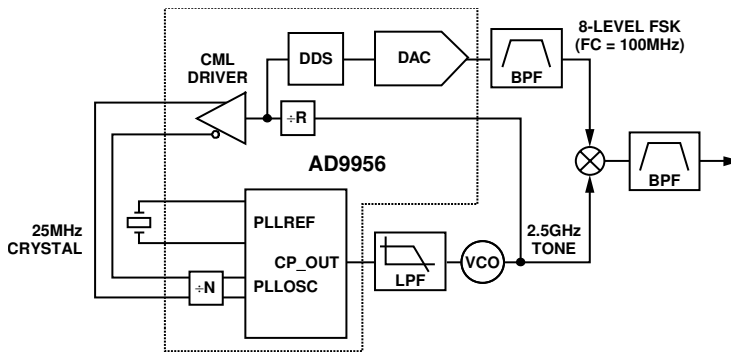

Figure 24. LO and Baseband Modulation Generation

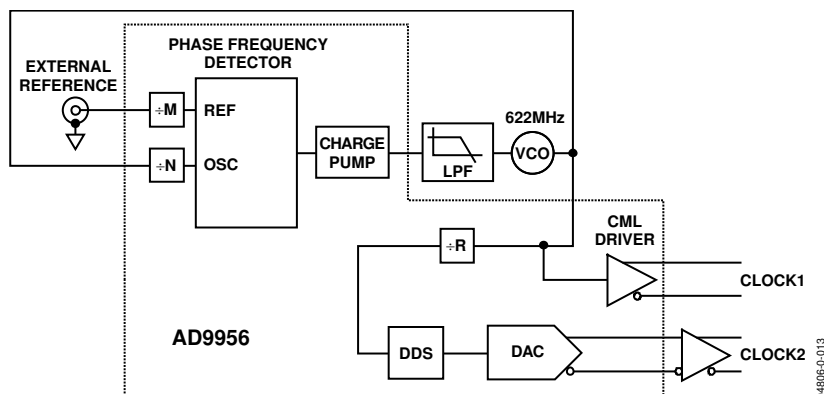

Figure 25. Optical Networking Clock

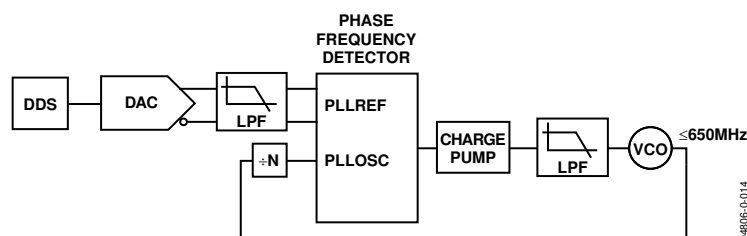

Figure 26. Direct Upconversion

APPLICATION CIRCUIT EXPLANATIONS

Dual-Clock Configuration

In this loop, $M = 1$, $N = 16$, and $R = 4$. The DDS tuning word is also equal to $\frac{1}{4}$ so that the frequency of CLOCK 1' equals the frequency of CLOCK 1. Phase adjustments in the DDS provide a 14-bit programmable rising edge skew capability of CLOCK 1' with respect to CLOCK 1 (see Figure 22).

Fractional-Divider Loop

This loop offers the precise frequency division (48-bit) of the DDS in the feedback path as well as the frequency sweeping capability of the DDS. Programming the DDS to sweep from 24 MHz to 25 MHz sweeps the output of the VCO from 2.7 GHz to 2.6 GHz. The reference in this case is a simple crystal (see Figure 23).

LO and Baseband Modulation Generation

Using the AD9956's PLL section to generate an LO and the DDS portion to generate a modulated baseband, this circuit uses an external mixer to perform some simple modulation at RF frequencies (see Figure 24).

Optical Networking Clock

This is the AD9956 configured as an optical networking clock. The loop can be used to generate a 622 MHz clock for OC12. The DDS can be programmed to output 8 kHz to serve as a base reference for other circuits in the subsystem (see Figure 25).

Direct Upconversion

The AD9956 is configured to use the DDS as a precision reference to the PLL loop. Since the VCO is < 655 MHz, it can be fed straight into the phase frequency detector feedback input (with the divider enabled), as seen in Figure 26.

GENERAL DESCRIPTION

DDS CORE

The DDS can create digital phase relationships by clocking a 48-bit accumulator. The incremental value loaded into the accumulator, known as the frequency tuning word, controls the overflow rate of the accumulator. Similar to a sine wave completing a 2π radian revolution, the overflow of the accumulator is cyclical in nature and generates a base frequency according to the following equation.

$$f_o = \frac{FTW \times (f_s)}{2^{48}} \quad \{0 \leq FTW \leq 2^{47}\}$$

The instantaneous phase of the sine wave is, therefore, the output of the phase accumulator block. This signal can be phase-offset by programming an additive digital phase added to each and every phase sample coming out of the accumulator.

These instantaneous phase values are then piped through a phase-to-amplitude conversion (sometimes called an angle-to-amplitude conversion or AAC) block. This algorithm follows a $\text{COS}(x)$ relationship where x is the phase coming out of the phase offset block, normalized to 2π .

Finally, the amplitude words are piped to a 14-bit DAC. Because the DAC is a sampled data system, the output is a reconstructed sine wave that needs to be filtered to take high frequency images out of the spectrum. The DAC is a current-steering DAC that is AVDD referenced. To get a measurable voltage output, the DAC outputs must terminate through a load resistor to AVDD, typically 50Ω . At positive full scale, IOUT sinks no current and the voltage drop across the load resistor is zero. However, the $\overline{\text{IOUT}}$ output sinks the DAC's programmed full-scale output current, causing the maximum output voltage to drop across the load resistor. At negative full-scale, the situation is reversed and IOUT sinks the full-scale current (and generates the maximum drop across the load resistor). At the same time, $\overline{\text{IOUT}}$ sinks no current (and generates no voltage drop). At midscale, the outputs sink equal amounts of current, generating equal voltage drops.

PLL CIRCUITRY

The AD9956 includes an RF divider (divide-by-R), a phase frequency detector, and a programmable output current charge pump. Incorporating these blocks together, users can generate many useful circuits for frequency synthesis. A few simple examples are shown in the Typical Application Circuits.

The RF divider accepts differential or single-ended signals up to 2.7 GHz. The RF divider also supplies the SYSCLK input to the DDS. Because the DDS operates up to only 400 MSPS, device function requires that for any RF input signal $> 400 \text{ MHz}$, the RF divider be engaged. The RF divider can be programmed to take values of 1, 2, 4, or 8. The ratio for the divider is programmed in the control register. The output of the divider can be routed to the input of the on-chip CML driver. For lower frequency input signals, it is possible to use the divider to divide the input signal to the CML driver and use the undivided input of the divider as the SYSCLK input to the DDS, or vice versa. In all cases, the clock to the DDS should not exceed 400 MSPS.

The on-chip phase frequency detector has two differential inputs, PLLREF (the reference input) and PLLOSC (the feedback or oscillator input). These differential inputs can be driven by single-ended signals; however, when doing so, tie the unused input through a 100 pF capacitor to the analog supply (AVDD). The maximum speed of the phase frequency detector inputs is 200 MHz. Each of the inputs has a buffer and a divider ($\div M$ on PLLREF and $\div N$ on PLLOSC) that operates at up to 655 MHz. If the signal exceeds 200 MHz, however, the divider must be used. The dividers are programmed through the control registers and take any integer value between 1 and 16.

The PLLREF input also has the option of engaging an in-line oscillator circuit. Engaging this circuit means that the PLLREF input can be driven with a crystal in the of $20 \text{ MHz} \leq \text{PLLREF} \leq 30 \text{ MHz}$ range.

The charge pump outputs a current in response to an error signal generated in the phase frequency detector. The output current is programmed through by placing a resistor (CP_RSET) from the CP_RSET pin to ground. The value is dictated by the following equation:

$$\text{CP_OUT} = \frac{1.55}{\text{CP_RSET}}$$

This sets the charge pump's reference output current. Also, a programmable scaler multiplies this base value by any integer from 1 to 8, programmable through the CP current scale bits in the Control Function Register 2, $\text{CFR2}\langle 2:0 \rangle$.

CML DRIVER

For clocking applications, an on-chip current mode logic (CML) driver is included. This CML driver generates very low jitter clock edges. The outputs of the CML driver are current outputs and drives PECL levels when terminated into a $100\ \Omega$ load. The base output current of the driver is programmed by attaching a resistor from the DRV_RSET pin to ground (nominally $4.02\ \text{k}\Omega$ for a continuous current of $7.2\ \text{mA}$). An optional on-chip current programming resistor is enabled by setting a bit in the control register. The rising edge and falling edge slew rates are independently programmable to help control overshoot and ringing through the application of surge current during rising edge transitions and falling edge transitions (see Figure 27). There is a default surge current of $7.6\ \text{mA}$ on the rising edge and $4.05\ \text{mA}$ on the falling edge. Bits in the control register enable additional rising edge and falling edge surge current, as well as disable the default surge current (see the Control Function Register Descriptions section for details). The CML driver can be driven by the

- RF divider input
- RF divider output
- PLLOSC input

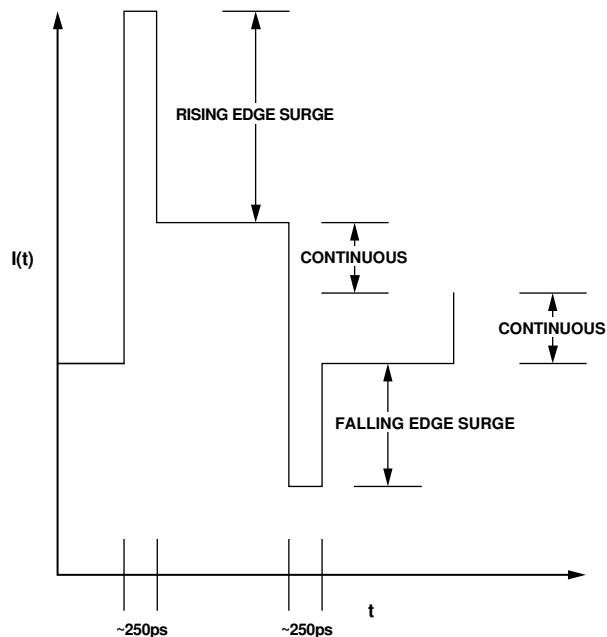

Figure 27. Rising Edge and Falling Edge Surge Current Output of the CML Clock Driver, as Opposed to the Steady State Continuous Current

MODES OF OPERATION

DDS MODES OF OPERATION

Single-Tone Mode

This is the default mode of operation for the DDS core. The phase accumulator runs at a fixed frequency, as per the active profile's tuning word. Likewise, any phase offset applied to the signal is a static value, which comes from the phase offset word of the active profile. The device has eight different phase/frequency profiles, each with its own 48-bit frequency tuning word and 14-bit phase offset word. Profiles are selected by applying their digital value on the profile-select pins (PS2, PS1, and PS0). It is impossible to use the phase offset of one profile and the frequency tuning word of another.

Linear Sweep Mode

This mode is entered by setting the linear sweep enable bit in the control register ($CFR1<17> = 1$) but leaving the linear sweep no dwell bit clear ($CFR1<16> = 0$). When the part is in linear sweep mode, the frequency accumulator ramps the output frequency of the device from a programmed lower frequency to a programmed upper frequency or from the upper frequency to the lower frequency. The lower frequency is set by the frequency tuning word stored in Profile 0, and the upper frequency is set by the frequency tuning word stored in Profile 1.

The combinational logic within the frequency accumulator requires that the value stored at FTW0 must always be less than the value stored in FTW1. The direction of the sweep (sweep up to FTW1, sweep down to FTW0) is controlled by the PS0 pin. A high state on this pin tells the part to sweep up to FTW1. A low state on this pin tells the part to sweep down to FTW0. The frequency accumulator requires four values, which are stored in the register map. First, it requires an incremental frequency value that tells the frequency accumulator how big of a frequency step to take each time it takes a step when ramping up. This value is stored in the rising delta frequency tuning word (RDFTW). The second value required is the rate at which the frequency accumulator should increment, that is, how often it should take a step. This value is stored in the rising sweep ramp rate word (RSRR). The RSRR value specifies the number of SYNC_CLK cycles the frequency accumulator should count between steps. The third and fourth values are the falling ramp equivalents, the falling delta frequency tuning word (FDFTW) and the falling sweep ramp rate (FSRR).

When operating in the linear sweep default mode, combinational logic ensures that the part never ramps up past FTW1, even if the next RDFTW increments the frequency past FTW1. Once it reaches FTW1, as long as the PS0 pin stays high, the frequency remains at FTW1. Likewise, the internal logic ensures that the part never ramps down past FTW0, even if the next RDFTW increments the frequency past FTW0. During a sweep down ($PS0 = 0$), once the part reaches FTW0, as long as the PS0 pin stays low, the frequency remains at FTW0.

If a sweep is interrupted and the state of the PS0 pin is changed during the midst of a sweep, the part begins sweeping in the new direction at the rate dictated by the relevant delta frequency tuning word and sweep ramp rate word. For example, if the part is programmed to sweep from 100 MHz to 140 MHz and to take 1 kHz steps every 1000 sync clock cycles (rising and falling sweep words are the same), it would take four seconds to complete a sweep. If the PS0 has been low for a very long time (more than four seconds), changing the PS0 pin to high starts a sweep up to 140 MHz. If after two seconds (not enough time for a full sweep in this example) the PS0 pin is brought low again, the part begins sweeping down from the current value, roughly 120 MHz.

Linear Sweep No Dwell Mode

This mode is entered by setting the linear sweep enable bit and the linear sweep no dwell bit in the control register ($CFR<17:16> = 1$). When the part is in linear sweep no dwell mode, the frequency accumulator ramps the output frequency of the device from a programmed lower frequency to a programmed upper frequency. Upon reaching the upper frequency, the accumulator returns to the lower frequency directly, without ramping back down. Unlike the default mode of the linear sweep, this mode uses only the rising delta frequency tuning word (RDFTW) and the rising sweep ramp rate (RSRR). The operation is still controlled by the PS0 pin. In this mode, however, it acts as a trigger for the sweep, not a direction bit. Once a PS0 low-to-high transition is detected, the part completes the entire sweep, regardless of whether or not the PS0 pin is changed back to low during the sweep. After the sweep is completed, another sweep may be initiated by applying another rising edge on the PS0 pin. This means that the PS0 pin needs to be brought low prior to the next sweep.

SYNCHRONIZATION MODES FOR MULTIPLE DEVICES

In a DDS system, the SYNC_CLK is derived internally off the master system clock, SYSCLK, with a $\div 4$ divider. Because the divider does not power up to a known state, it is possible for multiple devices in a system to have staggered clock-phase relationships. This is because each device could potentially generate the SYNC_CLK rising edge from any one of four rising edges of SYSCLK. This ambiguity can be resolved by employing digital synchronization logic to control the phase relationships of the derived clocks among different devices in the system. It is important to note that the synchronization functions included on the AD9956 control only the timing relationships among different digital clocks. They do not compensate for the analog timing skew on the system clock due to mismatched phase relationships on the input clock, REFCLK. Figure 28 illustrates this concept.

Automatic Synchronization

In automatic synchronization mode, the device is placed into slave mode and automatically aligns the internal SYNC_CLK to a master SYNC_CLK signal, supplied on the SYNC_IN input. When this bit is enabled, the PLL_LOCK is not available as an output, however, an out-of-lock condition can be detected by reading Control Function Register 1 and checking the status of the PLL_LOCK_ERROR bit, CFR1<24>. The automatic synchronization function is enabled by setting the Control Function Register 1 automatic synchronization bit, CFR1<3>. To employ this function at higher clock rates (SYNC_CLK > 62.5 MHz and SYSCLK > 250 MHz), the high speed sync enable bit (CFR1<0>) should be set as well.

Manual Synchronization, Hardware Controlled

In this mode, the user controls the timing relationship of the SYNC_CLK with respect to SYSCLK. When hardware manual synchronization is enabled, the PLL_LOCK/ SYNC_IN pin becomes a digital input. For each and every rising edge detected on the SYNC_IN input, the device advances the SYNC_IN rising edge by one SYSCLK period. When this bit is enabled, the PLL_LOCK is not available as an output. However, an out-of-lock condition can be detected by reading Control Function Register 1 and checking the status of the PLL Lock Error bit, CFR1<24>. This synchronization function is enabled by setting the hardware manual synchronization enable bit, CFR1<1>.

Manual Synchronization, Software Controlled

In this mode, the user controls the timing relationship between SYNC_CLK and SYSCLK through software programming. When the software manual synchronization bit (CFR1<2>) is set high, the SYNC_CLK is advanced by one SYSCLK cycle. Once this operation is complete, the bit is cleared. The user can set this bit repeatedly to advance the SYNC_CLK rising edge multiple times. Because the operation does not use the PLL_LOCK/ SYNC_IN pin as a SYNC_IN input, the PLL_LOCK signal can be monitored on the PLL_LOCK pin during this operation.

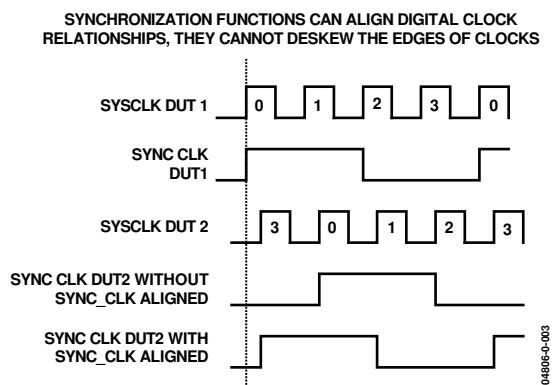

Figure 28. Synchronization Functions: Capabilities and Limitations

SERIAL PORT OPERATION

An AD9956 serial data-port communication cycle has two phases. Phase 1 is the instruction cycle, which is the writing of an instruction byte to the AD9956, coincident with the first eight SCLK rising edges. The instruction byte provides the AD9956 serial port controller with information regarding the data transfer cycle, which is Phase 2 of the communication cycle. The Phase 1 instruction byte defines whether the upcoming data transfer is read or write and the serial address of the register being accessed.

The first eight SCLK rising edges of each communication cycle are used to write the instruction byte into the AD9956. The remaining SCLK edges are for Phase 2 of the communication cycle. Phase 2 is the actual data transfer between the AD9956 and the system controller. The number of bytes transferred during Phase 2 of the communication cycle is a function of the

register being accessed. For example, when accessing Control Function Register 2, which is four bytes wide, Phase 2 requires that four bytes be transferred. If accessing a frequency tuning word, which is six bytes wide, Phase 2 requires that six bytes be transferred. After transferring all data bytes per the instruction, the communication cycle is completed.

At the completion of any communication cycle, the AD9956 serial port controller expects the next eight rising SCLK edges to be the instruction byte of the next communication cycle. All data input to the AD9956 is registered on the rising edge of SCLK. All data is driven out of the AD9956 on the falling edge of SCLK. Figure 29 through Figure 32 are useful in understanding the general operation of the AD9956 serial port.

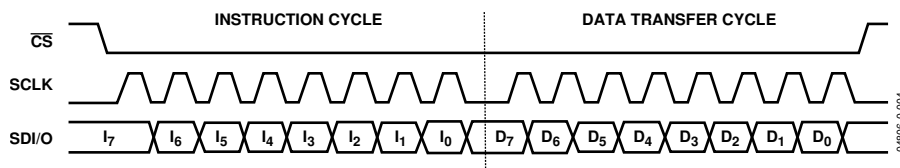

Figure 29. Serial Port Write Timing—Clock Stall Low

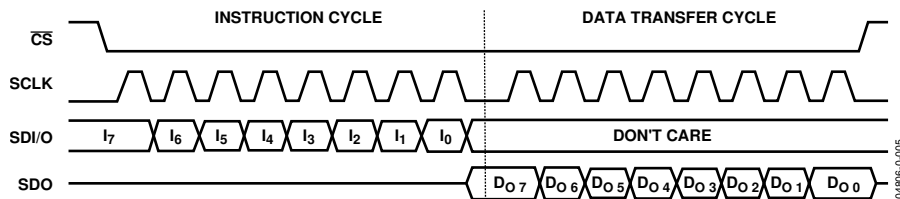

Figure 30. 3-Wire Serial Port Read Timing—Clock Stall Low

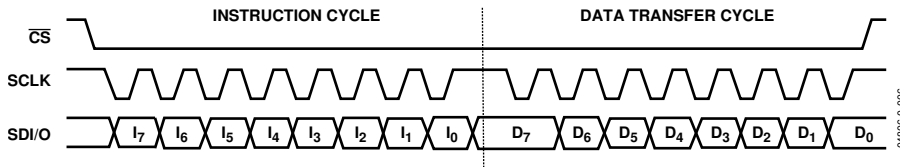

Figure 31. Serial Port Write Timing—Clock Stall High

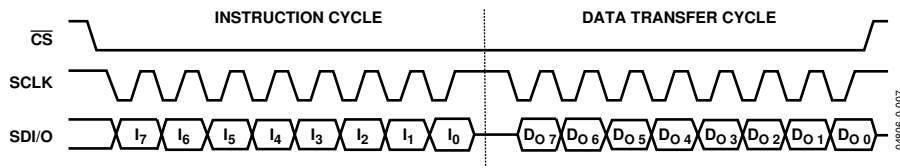

Figure 32. 2-Wire Serial Port Read Timing—Clock Stall High

INSTRUCTION BYTE

The instruction byte contains the following information:

Table 4.

D7	D6	D5	D4	D3	D2	D1	D0
R/Wb	X	X	A4	A3	A2	A1	A0

R/Wb—Bit 7 of the instruction byte determines whether a read or write data transfer occurs after the instruction byte write. Logic 1 indicates a read operation. Logic 0 indicates a write operation.

X, X—Bits 6 and 5 of the instruction byte are Don't Care.

A4 to A0—Bits 4 to 0 of the instruction byte determine which register is accessed during the data transfer portion of the communications cycle.

SERIAL INTERFACE PORT PIN DESCRIPTION

SCLK—Serial Clock. The serial clock pin is used to synchronize data to and from the AD9956 and to run the internal state machines. The SCLK maximum frequency is 25 MHz.

\overline{CS} —Chip Select Bar. \overline{CS} is an active low input that allows more than one device on the same serial communications line. The SDO and SDI/O pins go to a high impedance state when this input is high. If driven high during any communications cycle, that cycle is suspended until \overline{CS} is reactivated low. Chip select can be tied low in systems that maintain control of SCLK.

SDI/O—Serial Data Input/Output. Data is always written to the AD9956 on this pin. However, this pin can be used as a bidirectional data line. CFR1<7> controls the configuration of this pin. The default value (0) configures the SDI/O pin as bidirectional.

SDO—Serial Data Out. Data is read from this pin for protocols that use separate lines for transmitting and receiving data. When the AD9956 operates in a single bidirectional I/O mode, this pin does not output data and is set to a high impedance state.

I/O_RESET—A high signal on this pin resets the I/O port state machines without affecting the addressable registers' contents. An active high input on the I/O_RESET pin causes the current communication cycle to abort. After I/O_RESET returns low (0), another communication cycle can begin, starting with the instruction byte write. Note that when not in use, this pin should be forced low, because it floats to the threshold value.

MSB/LSB TRANSFERS

The AD9956 serial port can support both most significant bit (MSB) first or least significant bit (LSB) first data formats. This functionality is controlled by the LSB first bit in Control Register 1 (CFR1<15>). The default value of this bit is low (MSB first). When CFR1 <15> is set high, the AD9956 serial port is in LSB first format. The instruction byte must be written in the format indicated by CFR1 <15>. If the AD9956 is in LSB first mode, the instruction byte must be written from least significant bit to most significant bit. However, the instruction byte phase of the communications cycle still precedes the data transfer cycle.

For MSB first operation, all data written to (read from) the AD9956 are in MSB first order. If the LSB mode is active, all data written to (read from) the AD9956 are in LSB first order.

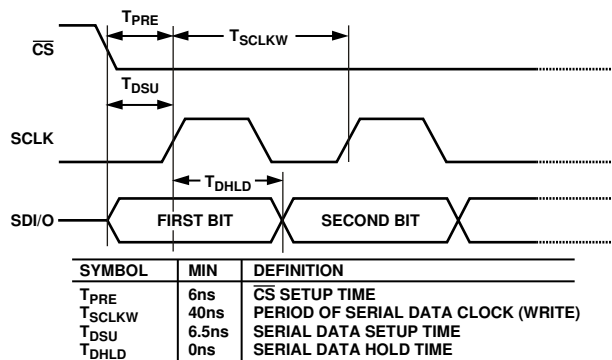

Figure 33. Timing Diagram for Data Write to AD9956

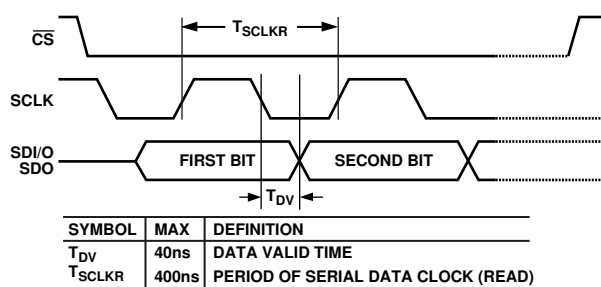

Figure 34. Timing Diagram for Data Read to AD9956

REGISTER MAP AND DESCRIPTION

Table 5.

Register Name (Serial Address)	Bit Range	(MSB) Bit 7	Bit 6	Bit 5	Bit 4	Bit 3	Bit 2	Bit 1	Bit 0 (LSB)	Default Value/ Profile
Control Function Register 1 (CFR1) (0x00)	<31:24>	Open ¹	Open ¹	Open ¹	Open ¹	Open ¹	Open ¹	Open ¹	PLL Lock Error	0x00
	<23:16>	LOAD SRR @ I/O_UPDATE	Auto-Clr Frequency Accum.	Auto-Clr Phase Accum.	Enable Sine Output	Clear Frequency Accum.	Clear Phase Accum.	Linear Sweep Enable	Linear Sweep No Dwell	0x00
	<15:8>	LSB First	SDI/O Input Only	Open ¹	Open ¹	Open ¹	Open ¹	Open ¹	Open ¹	0x00
	<7:0>	Digital Power-Down	PFD Input Power-Down	PLLREF Crystal Enable	SYNC_CLK Disable	Auto Sync Multiple AD9956s	Software Manual Sync	Hardware Manual Sync	High Speed Sync Enable	0x00
Control Function Register 2 (CFR2) (0x01)	<39:32>	DAC Power-Down	Open ¹	Open ¹	Open ¹	Open ¹	Open ¹	Internal Band Gap Power-Down	Internal CML Driver DRV_RSET	0x00
	<31:24>	Clock Driver Rising Edge <31:29>			Clock Driver Falling Edge Control <28:26>			PLL Lock Detect Enable	PLL Lock Detect Mode	0x00
	<23:16>	RF Divider Power-Down	RF Divider Ratio <22:21>	Clock Driver Power-Down	Clock Driver Input Select <19:18>		Slew Rate Control	RF Div REFCLK Mux Bit	0x78	
	<15:8>	Divider N Control <15:12>				Divider M Control <11:8>				0x00
	<7:0>	Open ¹	Open ¹	CP Polarity	CP Full PD	CP Quick PD	CP Current Scale <2:0>			0x07
Rising Delta Frequency Tuning Word (RDFTW) (0x02)	<23:16>	Rising Delta Frequency Tuning Word <23:16>								0x00
	<15:8>	Rising Delta Frequency Tuning Word <15:8>								0x00
	<7:0>	Rising Delta Frequency Tuning Word <7:0>								0x00
Falling Delta Frequency Tuning Word (FDFTW) (0x03)	<23:16>	Falling Delta Frequency Tuning Word <23:16>								0x00
	<15:8>	Falling Delta Frequency Tuning Word <15:8>								0x00
	<7:0>	Falling Delta Frequency Tuning Word <7:0>								0x00
Rising Sweep Ramp Rate (RSRR) (0x04)	<15:8>	Rising Sweep Ramp Rate <15:8>								0x00
	<7:0>	Rising Sweep Ramp Rate <7:0>								0x00
Falling Sweep Ramp Rate (FSRR) (0x05)	<15:8>	Rising Sweep Ramp Rate <15:8>								0x00
	<7:0>	Rising Sweep Ramp Rate <7:0>								0x00

¹ In all cases, open bits must be written to 0.

Register Name (Serial Address)	Bit Range	(MSB) Bit 7	Bit 6	Bit 5	Bit 4	Bit 3	Bit 2	Bit 1	Bit 0 (LSB)	Default Value/ Profile
Profile Control Register No. 0 (PCR0) (0x06)	<63:56>	Open ¹		Phase Offset Word 0 (POW0) <13:8>						0x00
	<55:48>	Phase Offset Word 0 (POW0) <7:0>						0x00		
	<47:40>	Frequency Tuning Word 0 (FTW0) <47:40>						0x00		
	<39:32>	Frequency Tuning Word 0 (FTW0) <39:32>						0x00		
	<31:24>	Frequency Tuning Word 0 (FTW0) <31:24>						0x00		
	<23:16>	Frequency Tuning Word 0 (FTW0) <23:16>						0x00		
	<15:8>	Frequency Tuning Word 0 (FTW0) <15:8>						0x00		
	<7:0>	Frequency Tuning Word 0 (FTW0) <7:0>						0x00		
Profile Control Register No. 1 (PCR1) (0x07)	<63:56>	Open ¹		Phase Offset Word 1 (POW1) <13:8>						0x00
	<55:48>	Phase Offset Word 1 (POW1) <7:0>						0x00		
	<47:40>	Frequency Tuning Word 1 (FTW1) <47:40>						0x00		
	<39:32>	Frequency Tuning Word 1 (FTW1) <39:32>						0x00		
	<31:24>	Frequency Tuning Word 1 (FTW1) <31:24>						0x00		
	<23:16>	Frequency Tuning Word 1 (FTW1) <23:16>						0x00		
	<15:8>	Frequency Tuning Word 1 (FTW1) <15:8>						0x00		
	<7:0>	Frequency Tuning Word 1 (FTW1) <7:0>						0x00		
Profile Control Register No. 2 (PCR2) (0x08)	<63:56>	Open ¹		Phase Offset Word 2 (POW2) <13:8>						0x00
	<55:48>	Phase Offset Word 2 (POW2) <7:0>						0x00		
	<47:40>	Frequency Tuning Word 2 (FTW2) <47:40>						0x00		
	<39:32>	Frequency Tuning Word 2 (FTW2) <39:32>						0x00		
	<31:24>	Frequency Tuning Word 2 (FTW2) <31:24>						0x00		
	<23:16>	Frequency Tuning Word 2 (FTW2) <23:16>						0x00		
	<15:8>	Frequency Tuning Word 2 (FTW2) <15:8>						0x00		
	<7:0>	Frequency Tuning Word 2 (FTW2) <7:0>						0x00		
Profile Control Register No. 3 (PCR3) (0x09)	<63:56>	Open ¹		Phase Offset Word 3 (POW3) <13:8>						0x00
	<55:48>	Phase Offset Word 3 (POW3) <7:0>						0x00		
	<47:40>	Frequency Tuning Word 3 (FTW3) <47:40>						0x00		
	<39:32>	Frequency Tuning Word 3 (FTW3) <39:32>						0x00		
	<31:24>	Frequency Tuning Word 3 (FTW3) <31:24>						0x00		
	<23:16>	Frequency Tuning Word 3 (FTW3) <23:16>						0x00		
	<15:8>	Frequency Tuning Word 3 (FTW3) <15:8>						0x00		
	<7:0>	Frequency Tuning Word 3 (FTW3) <7:0>						0x00		

¹ In all cases, open bits must be written to 0.

AD9956

Register Name (Serial Address)	Bit Range	(MSB) Bit 7	Bit 6	Bit 5	Bit 4	Bit 3	Bit 2	Bit 1	Bit 0 (LSB)	Default Value/ Profile
Profile Control Register No. 4 (PCR4) (0x0A)	<63:56>	Open ¹		Phase Offset Word 4 (POW4) <13:8>						0x00
	<55:48>	Phase Offset Word 4 (POW4) <7:0>								0x00
	<47:40>	Frequency Tuning Word 4 (FTW4) <47:40>								0x00
	<39:32>	Frequency Tuning Word 4 (FTW4) <39:32>								0x00
	<31:24>	Frequency Tuning Word 4 (FTW4) <31:24>								0x00
	<23:16>	Frequency Tuning Word 4 (FTW4) <23:16>								0x00
	<15:8>	Frequency Tuning Word 4 (FTW4) <15:8>								0x00
	<7:0>	Frequency Tuning Word 4 (FTW4) <7:0>								0x00
Profile Control Register No. 5 (PCR5) (0x0B)	<63:56>	Open ¹		Phase Offset Word 5 (POW5) <13:8>						0x00
	<55:48>	Phase Offset Word 5 (POW5) <7:0>								0x00
	<47:40>	Frequency Tuning Word 5 (FTW5) <47:40>								0x00
	<39:32>	Frequency Tuning Word 5 (FTW5) <39:32>								0x00
	<31:24>	Frequency Tuning Word 5 (FTW5) <31:24>								0x00
	<23:16>	Frequency Tuning Word 5 (FTW5) <23:16>								0x00
	<15:8>	Frequency Tuning Word 5 (FTW5) <15:8>								0x00
	<7:0>	Frequency Tuning Word 5 (FTW5) <7:0>								0x00
Profile Control Register No. 6 (PCR6) (0x0C)	<63:56>	Open ¹		Phase Offset Word 6 (POW6) <13:8>						0x00
	<55:48>	Phase Offset Word 6 (POW6) <7:0>								0x00
	<47:40>	Frequency Tuning Word 6 (FTW6) <47:40>								0x00
	<39:32>	Frequency Tuning Word 6 (FTW6) <39:32>								0x00
	<31:24>	Frequency Tuning Word 6 (FTW6) <31:24>								0x00
	<23:16>	Frequency Tuning Word 6 (FTW6) <23:16>								0x00
	<15:8>	Frequency Tuning Word 6 (FTW6) <15:8>								0x00
	<7:0>	Frequency Tuning Word 6 (FTW6) <7:0>								0x00
Profile Control Register No. 7 (PCR7) (0x0D)	<63:56>	Open ¹		Phase Offset Word 7 (POW7) <13:8>						0x00
	<55:48>	Phase Offset Word 7 (POW7) <7:0>								0x00
	<47:40>	Frequency Tuning Word 7 (FTW7) <47:40>								0x00
	<39:32>	Frequency Tuning Word 7 (FTW7) <39:32>								0x00
	<31:24>	Frequency Tuning Word 7 (FTW7) <31:24>								0x00
	<23:16>	Frequency Tuning Word 7 (FTW7) <23:16>								0x00
	<15:8>	Frequency Tuning Word 7 (FTW7) <15:8>								0x00
	<7:0>	Frequency Tuning Word 7 (FTW7) <7:0>								0x00

¹ In all cases, open bits must be written to 0.

CONTROL FUNCTION REGISTER DESCRIPTIONS

Control Function Register 1 (CFR1)

This control register is comprised of four bytes, all of which must be written during a write operation involving CFR1. CFR1 is used to control various functions, features, and operating modes of the AD9956. The functionality of each bit(s) is described below. In general, the bit is named for the function it serves when the bit is set.

CFR1<31:25> Open. Unused locations. Write a Logic 0

CFR1<24> PLL Lock Error (Read-Only)

When the device is operating in automatic synchronization mode or hardware manual synchronization mode (see below), the PLL_LOCK/ SYNC_IN pin behaves as the SYNC_IN. To determine whether or not the PLL has become unlocked while in synchronization mode, this bit serves as a flag to indicate that an unlocked condition has occurred within the phase frequency detector. Once set, the flag stays high until it is cleared by a readback of the value even though the loop might have relocked. Readback of the CFR1 register clears this bit.

CFR1<24> = 0 indicates that the loop has maintained lock since the last readback.

CFR1<24> = 1 indicates that the loop became unlocked at some point since the last readback of this bit.

CFR1<23> Load Sweep Ramp Rate at I/O_UPDATE, also known as Load SRR @ I/O_UPDATE

The sweep ramp rate is set by entering a value to a down counter that is clocked by the SYNC_CLK. Each time a new step is taken in the linear sweep algorithm, the ramp rate value is passed from the linear sweep ramp rate register to this down counter. When set, CFR1<23>, enables the user to force the part to restart the countdown sequence for the current linear sweep step by toggling the I/O_UPDATE pin.

CFR1<23> = 0 (default). The linear sweep ramp rate countdown value is loaded only upon completion of a countdown sequence.

CFR1<23> = 1. The linear sweep ramp rate countdown value is reloaded, if an I/O_UPDATE signal is sent to the part during a sweep.

CFR1<22> Auto-Clear Frequency Accumulator

This bit enables the auto-clear function for the frequency accumulator. The auto-clear function serves as a clear and release function for the frequency accumulator (which performs the linear sweep operation), which then begins sweeping from a known value of FTW0.

CFR1 <22> = 0 (default). Issuing an I/O_UPDATE has no effect on the current state of the frequency accumulator.

CFR1 <22> = 1. Issuing an I/O_UPDATE signal to the part clears the current contents of the frequency accumulator for one sync-clock period.

CFR1 <21> Auto-Clear Phase Accumulator

This bit enables the auto-clear function for the phase accumulator. The auto-clear function serves as a reset function for the phase accumulator, which then begins accumulating from a known phase value of 0.

CFR1<21> = 0 (default). Issuing an I/O_UPDATE has no effect on the current state of the phase accumulator.

CFR1<21> = 1. Issuing an I/O_UPDATE clears the current contents of the phase accumulator for one SYNC_CLK period.

CFR1 <20> Enable Sine Output

Two different trigonometric functions can be used to convert the phase angle to an amplitude value, cosine or sine. This bit selects the function used.

CFR1<20> = 0 (default). The phase-to-amplitude conversion block uses a cosine function.

CFR1<20> = 1. The phase-to-amplitude conversion block uses a sine function.

CFR1 <19> Clear Frequency Accumulator

This bit serves as a static-clear or a clear-and-hold bit for the frequency accumulator. It prevents the frequency accumulator from incrementing the value as long as it is set.

CFR1 <19> = 0 (default). The frequency accumulator operates normally.

CFR1 <19> = 1. The frequency accumulator is cleared and held at a value of 0.

CFR1 <18> Clear Phase Accumulator

This bit serves as a static-clear or a clear-and-hold it for the phase accumulator. It prevents the phase accumulator from incrementing the value as long as it is set.

CFR1 <18> = 0 (default). The phase accumulator operates normally.

CFR1 <18> = 1. The phase accumulator is cleared and held at a value of 0.

CFR1 <17> Linear Sweep Enable

This bit turns on the frequency accumulator, which enables the DDS to perform linear sweeping.

CFR1<17> = 0 (default). The DDS generates frequencies in single-tone mode.

CFR1<17> = 1. The DDS uses the frequency accumulator to sweep the frequency tuning word being sent to the phase accumulator according to the values set in the delta frequency tuning word and delta frequency ramp rate registers. For a detailed explanation of this mode, see the linear sweep mode of operation section.

CFR1 <16> Linear Sweep No Dwell

This bit dictates the behavior of the DDS core upon completion of a linear sweep.

CFR1<16> = 0 (default). Upon reaching the upper value of the sweep (FTW1), the DDS holds at the frequency value stored in FTW1.

CFR1<16> = 1. Upon reaching the upper value of the sweep (FTW1), the DDS returns to the initial value in the sweep (FTW0) and continues to output that frequency until a new sweep is initiated (by bringing PS0 low and then high).

CFR1 <15> LSB First Serial Data Mode

The serial data transfer to the device can be either MSB first or LSB first. This bit controls that operation.

CFR1<15> = 0 (default). Serial data transfer to the device is in MSB first mode.

CFR1<15> = 1. Serial data transfer to the device is in LSB first mode.

CFR1<14> SDI/O Input Only (3-Wire Serial Data Mode)

The serial port on the AD9956 can act in 2-wire mode (SCLK and SDI/O) or 3-wire mode (SCLK, SDI/O, and SDO). This bit toggles the serial port between these two modes.

CFR1<14> = 0 (default). Serial data transfer to the device is in 2-wire mode. The SDI/O pin is bidirectional.

CFR1<14> = 1. Serial data transfer to the device is in 3-wire mode. The SDI/O pin is input only.

CFR1<13:8> Open

Unused locations. Write a Logic 0.

CFR1<7> Digital Power-Down

This bit powers down the digital circuitry not directly related to the I/O port. The I/O port functionality is not suspended, regardless of the state of this bit.

CFR1<7> = 0 (default). Digital logic operating as normal.

CFR1<7> = 1. All digital logic not directly related to the I/O port is powered down. Internal digital clocks are suspended.

CFR1<6> Phase Frequency Detector Input Power-Down

This bit controls the input buffers on the phase frequency detector. It provides a way to gate external signals from the phase frequency detector itself.

CFR1<6> = 0 (default). Phase frequency detector input buffers are functioning normally.

CFR1<6> = 1. Phase frequency detector input buffers are powered down, isolating the phase frequency detector from the outside world.

CFR1<5> PLLREF Crystal Enable

The AD9956 phase frequency detector has an on-chip oscillator circuit. When enabled, the reference input to the phase frequency detector (PLLREF/PLLREF) can be driven by a crystal.

CFR1<5> = 0 (default). Phase frequency detector reference input operates as a standard analog input.

CFR1<5> = 1. Reference input oscillator circuit is enabled, allowing the use of a crystal for the reference of the phase frequency detector.

CFR1<4> SYNC_CLK Disable

If synchronization of multiple devices is not required, the spectral energy resulting from this signal can be reduced by gating the output buffer off. This function gates the internal clock reference SYNC_CLK (SYSCLK/4) off of the SYNC_OUT pin.

CFR1<4> = 0 (default). SYNC_CLK signal is present on the SYNC_OUT pin and is ready to be ported to other devices.

CFR1<4> = 1. SYNC_CLK signal is gated off, putting the SYNC_OUT pin into a high impedance state.

CFR1<3> Automatic Synchronization

One of the synchronization modes of the AD9956 forces the DDS core to derive the internal reference from an external reference supplied on the SYNC_IN pin. For details on synchronization modes for the DDS core, see the Synchronization Modes for Multiple Devices section.

CFR1<3> = 0 (default). The automatic synchronization function of the DDS core is disabled.

CFR1<3> = 1. The automatic synchronization function is on. The device is slaved to an external reference and adjusts the internal SYNC_CLK to match the external reference, which is supplied on the SYNC_IN input.

CFR1<2> Software Manual Synchronization

Rather than relying on the part to automatically synchronize the internal clocks, the user can program the part to advance the internal SYNC_CLK one system clock cycle. This bit is self-clearing and can be set multiple times.

CFR1<2> = 0 (default). The SYNC_CLK stays in the current timing relationship to SYSCLK.

CFR1<2> = 1. The SYNC_CLK advances the rising and falling edges by one SYSCLK cycle. This bit is then self-cleared.

CFR1<1> Hardware Manual Synchronization

Similar to the software manual synchronization (CFR1<2>), this function enables the user to advance the SYNC_CLK rising edge by one system clock period. This bit enables the PLL_LOCK/SYNC_IN pin as a digital input. Once enabled, every rising edge on the SYNC_IN input advances the SYNC_CLK by one SYSCLK period. While enabled, the PLL_LOCK signal is not available on an external pin. However, loop out-of-lock events trigger a flag in the control register (CFR1<24>).

CFR1<1> = 0 (default). The hardware manual synchronization function is disabled. Either the part is outputting the PLL_LOCK (CFR1<3> = 0), or it is using the SYNC_IN to slave the SYNC_CLK signal to an external reference provided on SYNC_IN (CFR1<3> = 1).

CFR1<1> = 1. PLL_LOCK/SYNC_IN is set as a digital input. Each subsequent rising edge on this pin advances the SYNC_CLK rising edge by one SYSCLK period.

CFR1<0> High Speed Synchronization Enable Bit

This bit enables extra functionality in the auto synchronization algorithm, which enables the device to synchronize high speed clocks (SYNC_CLK > 62.5 MHz).

CFR1<0> = 0 (default). High speed synchronization is disabled.

CFR1<0> = 1. High speed synchronization is enabled.

Control Function Register 2 (CFR2)

This control register is comprised of five bytes, which must be written during a write operation involving CFR2. With some minor exceptions, the CFR2 primarily controls analog and timing functions on the AD9956.

CFR2<39> DAC Power-Down Bit

This bit powers down the DAC portion of the AD9956 and puts it into the lowest power dissipation state.

CFR2<39> = 0 (default). DAC is powered on and operating.

CFR2<39> = 1. DAC is powered down and the output is in a high impedance state.

CFR2<38> to CFR2<34> Open

Unused locations. Write a Logic 0.

CFR2<33> Internal Band Gap Power-Down

To shut off all internal quiescent current, the band gap needs to be powered down. This is normally not done because it takes a long time (~10 ms) for the band gap to power up and settle to its final value.

CFR2<33> = 0. Even when all other sections are powered down, the band gap is powered up and is providing a regulated voltage.

CFR2<33> = 1. The band gap is powered down.

CFR2<32> Internal CML Driver DRV_RSET

To program the CML driver's output current, a resistor must be placed between the DRV_RSET pin and ground. This bit enables an internal resistor to program the output current of the driver.

CFR2<32> = 0 (default). The DRV_RSET pin is enabled, and an external resistor must be attached to the CP_RSET pin to program the output current.

CFR2<32> = 1. The CML current is programmed by the internal resistor and ignores the resistor on the DRV_REST pin.

CFR2<31:29> Clock Driver Rising Edge

These bits control the slew rate of the CML clock driver output's rising edge. When these bits are on, additional current is sent to the output driver to increase the rising edge slew rate capability; the contributions of each bit are cumulative. Table 6 describes how the bits increase the current. Note that the additional current is on only during the rising edge of the waveform for approximately 250 ps, but not on during the entire transition.

Table 6. CML Clock Driver Rising Edge Slew Rate Control Bits and Associated Surge Current

CFR2<31> = 1	7.6 mA
CFR2<30> = 1	3.8 mA
CFR2<29> = 1	1.9 mA

CFR2<28:26> Clock Driver Falling Edge Control

These bits control the slew rate of the CML clock driver output's falling edge. When these bits are on, additional current is sent to the output driver to increase the rising edge slew rate capability. Table 7 describes how the bits increase the current; the contributions of each bit are cumulative. Note that the additional current is on only during the rising edge of the waveform, for approximately 250 ps, but not on during the entire transition.

Table 7. CML Clock Drive Falling Edge Slew Rate Control Bits and Associated Surge Current

CFR2<28> = 1	5.4 mA
CFR2<30> = 1	2.7 mA
CFR2<29> = 1	1.35 mA

CFR2<25> PLL_LOCK_DETECT Enable

This bit enables the PLL_LOCK/SYNC_IN pin as a lock detect output for the PLL.

CFR2<25> = 0 (default). The PLL_LOCK_DETECT signal is disabled.

CFR2<25> = 1. The PLL_LOCK_DETECT signal is enabled.

CFR2<24> PLL_LOCK_DETECT Mode

This bit toggles the modes of the PLL_LOCK_DETECT function. The lock detect can either be a status indicator (locked or unlocked), or it can indicate a lead-lag relationship between the two phase frequency detector inputs.

CFR2<24> = 0 (default). The lock detect acts as a status indicator (PLL is locked 0 or unlocked 1).

CFR2<24> = 1. The lock detect acts as a lead/lag indicator. A 1 on the PLL_LOCK pin means that the PLLOSC pin lags the reference. A 0 means that the PLLOSC pin leads the reference.

CFR2<23> RF Divider Power-Down

This bit powers the RF divider down to save power when not in used.

CFR2<23> = 0 (default). RF divider is on.

CFR2<23> = 1. RF divider is powered down and an alternate path between the REFCLK inputs and SYSCLK is enabled.

CFR2<22:21> RF Divider Ratio

These two bits control the RF divider ratio ($\div R$).

CFR2<22:21> = 11 (default). RF Divider R = 8.

CFR2<22:21> = 10. RF Divider R = 4.

CFR2<22:21> = 01. RF Divider R = 2.

CFR2<22:21> = 00. RF Divider R = 1. Note that this is not the same as bypassing the RF divider.

CFR2<20> Clock Driver Power-Down

This bit powers down the CML clock driver circuit.

CFR2<20> = 1 (default). CML clock driver circuit is powered down.

CFR2<20> = 0. CML clock driver is powered up.

CFR2<19:18> Clock Driver Input Select

These bits control the mux on the input for the CML clock driver.

CFR2<19:18> = 00. The CML clock driver is disconnected from all inputs (and does not toggle).

CFR2<19:18> = 01. The CML clock driver is driven by the PLLOSC input pin.

CFR2<19:18> = 10 (default). The CML clock driver is driven by the output of the RF divider.

CFR2<19:18> = 11. The CML clock driver is driven by the input of the RF divider

CFR2<17> Slew Rate Control Bit

Even without the additional surge current supplied by the rising edge slew rate control bits and the falling edge slew rate control bits, the device applies a default 7.6 mA surge current to the rising edge and a 4.05 mA surge current to the falling edge. This bit disables all slew rate enhancement surge current, including the default values.

CFR2<17> = 0 (default). The CML driver applies default surge current to rising and falling edges.

CFR2<17> = 1. Driver applies no surge current during transitions. The only current is the continuous current.

CFR2<16> RF Divider SYSCLK Mux Bit

This bit toggles the mux to control whether the RF divider output or input is supplying SYSCLK to the device.

CFR2<16> = 0 (default). The RF divider output supplies the DDS SYSCLK.

CFR2<16> = 1. The RF divider input supplies the DDS SYSCLK (bypass the divider). Note that regardless of the condition of the configuration of the clock input, the DDS SYSCLK must not exceed the maximum rated clock speed.

CFR2<15:12> PLLREF Divider Control Bits ($\div N$)

These 4 bits set the PLLREF divider ($\div N$) ratio where N is a value equal to 1 to 16. CFR2<15:12> = 0000 means that $N = 1$ and CFR2<15:12> = 1111 means that $N = 16$, or simply, $N = \text{CFR2<15:12>} + 1$.

CFR2<15:12> =	N =	CFR2<15:12> =	N =
0000	1	1000	9
0001	2	1001	10
0010	3	1010	11
0011	4	1011	12
0100	5	1100	13
0101	6	1101	14
0110	7	1110	15
0111	8	1111	16

CFR2<11:8> PLLREF Divider Control Bits ($\div M$)

These 4 bits set the PLLOSC divider ($\div M$) ratio where M is a value equal to 1 to 16. CFR2<11:8> = 0000 means that $M = 1$ and CFR2<11:8> = 1111 means that $M = 16$, or $M = \text{CFR2<11:8>} + 1$.

CFR2<11:8> =	M =	CFR2<11:8> =	M =
0000	1	1000	9
0001	2	1001	10
0010	3	1010	11
0011	4	1011	12
0100	5	1100	13
0101	6	1101	14
0110	7	1110	15
0111	8	1111	16

CFR2<7:6> Open

Unused locations. Write a Logic 0.

CFR2<5> CP Polarity

This bit sets the polarity of the charge pump, in response to a ground referenced or a supply referenced VCO.

CFR2<5> = 0 (default). The charge pump is configured to operate with a supply referenced VCO. If PLLOSC lags PLLREF, the charge pump will attempt to drive the VCO control node voltage higher. If PLLOSC leads PLLREF, the charge pump will attempt to drive the VCO control node voltage lower.

CFR2<5> = 1. The charge pump is configured to operate with a ground referenced VCO. If PLLOSC lags PLLREF, the charge pump will attempt to drive the VCO control node voltage lower. If PLLOSC leads PLLREF, the charge pump will attempt to drive the VCO control node voltage higher.

CFR2<4> Charge Pump Full Power-Down

This bit, when set, will put the charge pump into a full power-down mode.

CFR2<4> = 0 (default). The charge pump is powered on and operating normally.

CFR2<4> = 1. The charge pump is completely powered down.

CFR2<3> Charge Pump Quick Power-Down

Rather than power down the charge pump, which can take a long time to recover from, a quick power-down mode, which powers down only the charge pump output buffer, is included. While this doesn't reduce the power consumption significantly, it does shut off the output to the charge pump and allows it to come back on in a rapidly.

CFR2<3> = 0 (default). The charge pump is powered on and operating normally.

CFR2<3> = 1. The charge pump is on and running, but the output buffer is powered down.

CFR2<2:0> Charge Pump Current Scale.

A base output current from the charge pump is determined by a resistor connected from the CP_RSET pin to ground (see the PLL Circuitry section). However, it is possible to multiply the charge pump output current by a value from 1:8 by programming these bits. The charge pump output current is scaled by CFR2<2:0> + 1.

CFR2<2:0> = 000 (default). Scale factor = 1 to CFR2<2:0> = 111 (8).

CFR2<2:0>	Scale Factor
000	1
001	2
010	3
011	4
100	5
101	6
110	7
111	8

OUTLINE DIMENSIONS

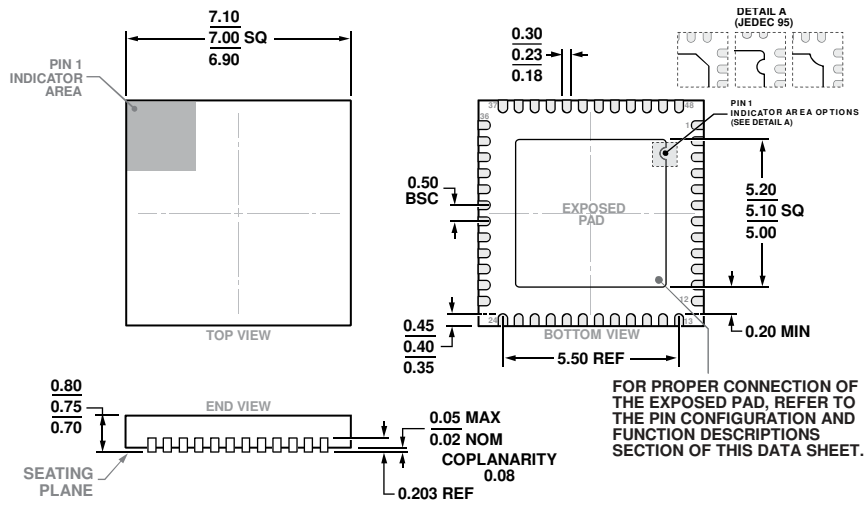

COMPLIANT TO JEDEC STANDARDS MO-220-WKKD-4

Figure 35. 48-Lead Lead Frame Chip Scale Package [LFCSP]
7 mm × 7 mm Body and 0.75 mm Package Height (CP-48-4)
Dimensions shown in millimeters

ORDERING GUIDE

Model	Temperature Range	Package Description	Package Option
AD9956YCPZ ¹	-40°C to +125°C	48-Lead Lead Frame Chip Scale Package (LFCSP)	CP-48-4
AD9956YCPZ-REEL ¹	-40°C to +125°C	48-Lead Lead Frame Chip Scale Package (LFCSP), Tape and Reel	CP-48-4
AD9956/PCB		Evaluation Board with No VCO and Charge Pump Filter	
AD9956-VCO/PCB		Evaluation Board with 2.4 GHz VCO and Charge Pump Filter	

¹ Z = Pb-free part.