

# WM15



## Power analyzer for three-phase systems



### Description

WM15 is a power analyzer for single-, two- and three-phase systems.

Depending on the model, WM15 is equipped with a static output (pulse or alarm), with a static output and a Modbus RTU communication port or with a static output and a M-Bus port.

The self-powered version can be installed on systems up to 415 V L-L (400 V L-L for MID models), while the version with auxiliary power supply can be installed on systems up to 600 V L-L.

### Applications

WM15 can be installed in any switchboard to control energy consumption, main electrical variables and harmonic distortion.

In panel boards, where typically three analogical ammeters are installed to give a visual feedback of the system status, WM15 provides the same information on the matrix display by means of the bar graphs.

When used to monitor a single machine, WM15 relates the energy consumption with the operating hours to schedule maintenance and detect faults. Moreover, the reset of partial counters allows to monitor each machine cycle.

Thanks to the MID certification, it can also be used for fiscal metrology.

### Main functions

- Measure main electrical variables and voltage and current harmonic distortions
- Measure active and reactive energy

### Benefits

- **Enhanced readability.** The backlit graphical display allows the size of the digits to be adapted to the displayed variable. The instantaneous values of the current are also shown by a bar graph to have the plant situation at a glance.
- **Easy navigation.** The setup and navigation of the pages are very intuitive thanks to the user interface with 4 mechanical push buttons. In addition, the slideshow function automatically displays the desired measurements in sequence without having to use the keypad.
- **Quick setup.** Wizard and wiring correction on first startup, UCS mobile app for setup via OptoProg and optical port are some of the advantages allowing a quick, guided and errorless installations and commissioning. UCS software is available for free download.
- **Accurate measurement.** It is compliant with the international accuracy standard IEC/EN62053-21, and the IEC/EN61557-12 performance requirements (active power and active energy). Optional high accuracy version: class 0.5S kWh according to IEC/EN62053-22.
- **Fiscal metrology.** WM15 configuration access can be locked and terminals can be sealed in case of a MID certified model for fiscal metering.
- **Installation flexibility.** WM15 is suitable for single-phase, two-phase, three-phase and wild-leg systems with different voltage levels and grid frequencies used worldwide.
- **Multi-language.** Chinese and Korean versions are available as alternative to the standard English user interface.

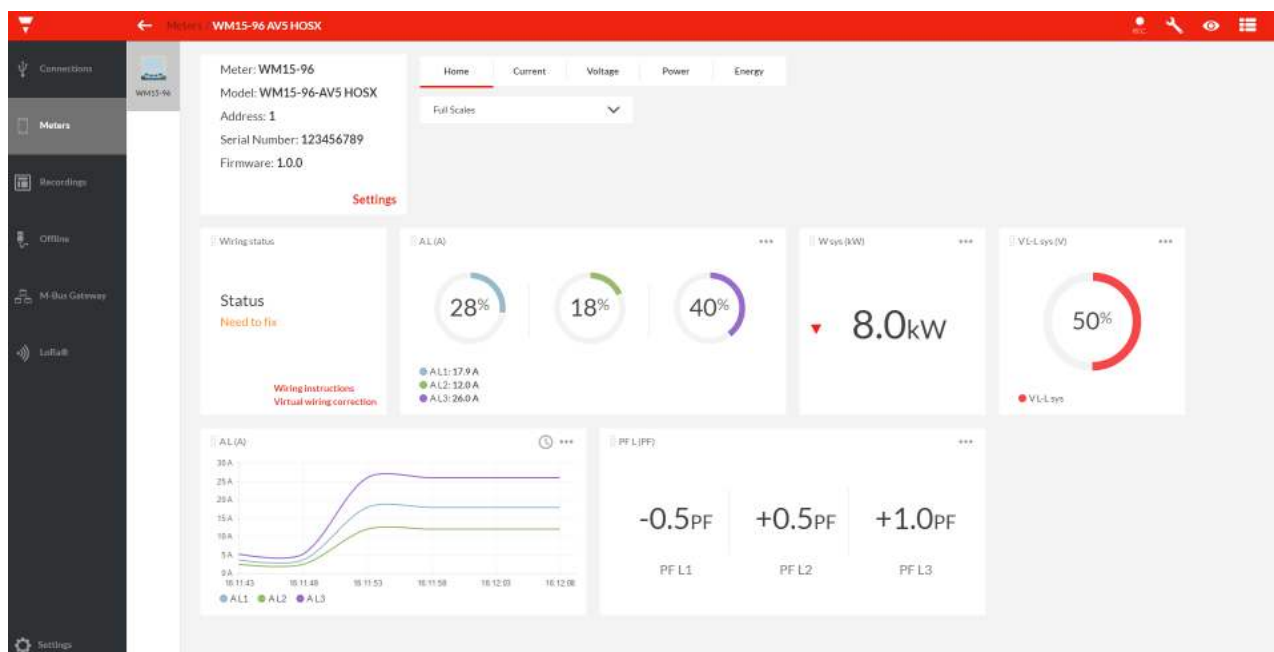
- Measure apparent energy
- Measure load operating hours
- Transmit data to other systems via Modbus RTU or M-Bus
- Manage a digital output for pulses or alarm transmission
- Visualize measured variables on display
- Visualize current consumption via bar graph

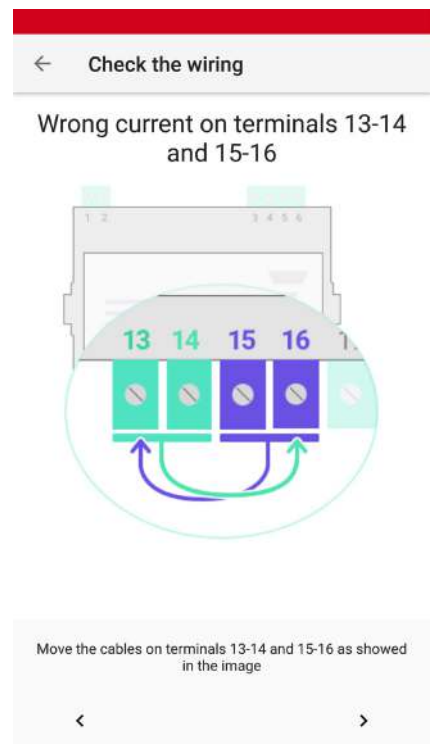
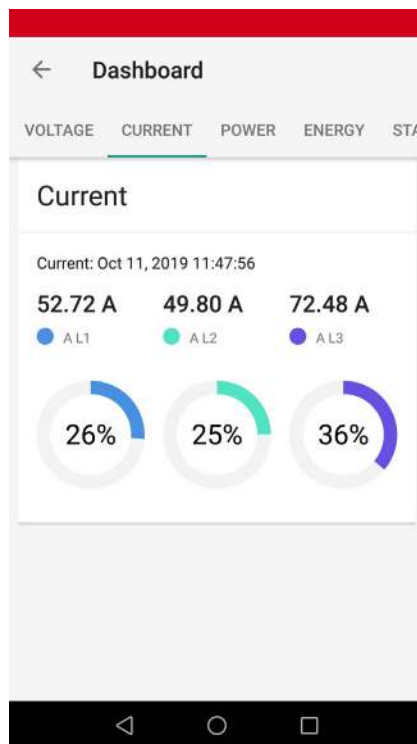
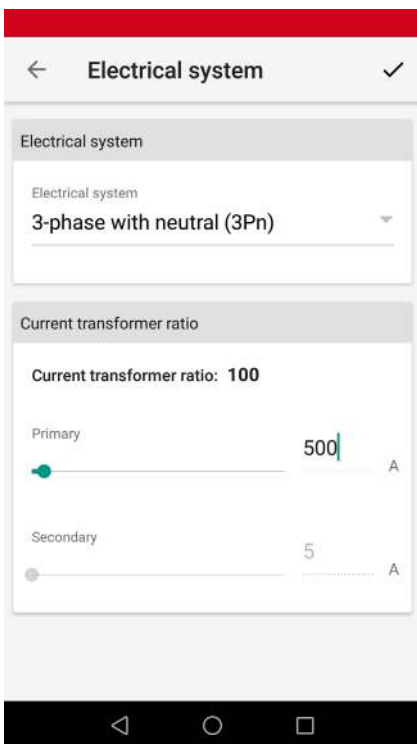
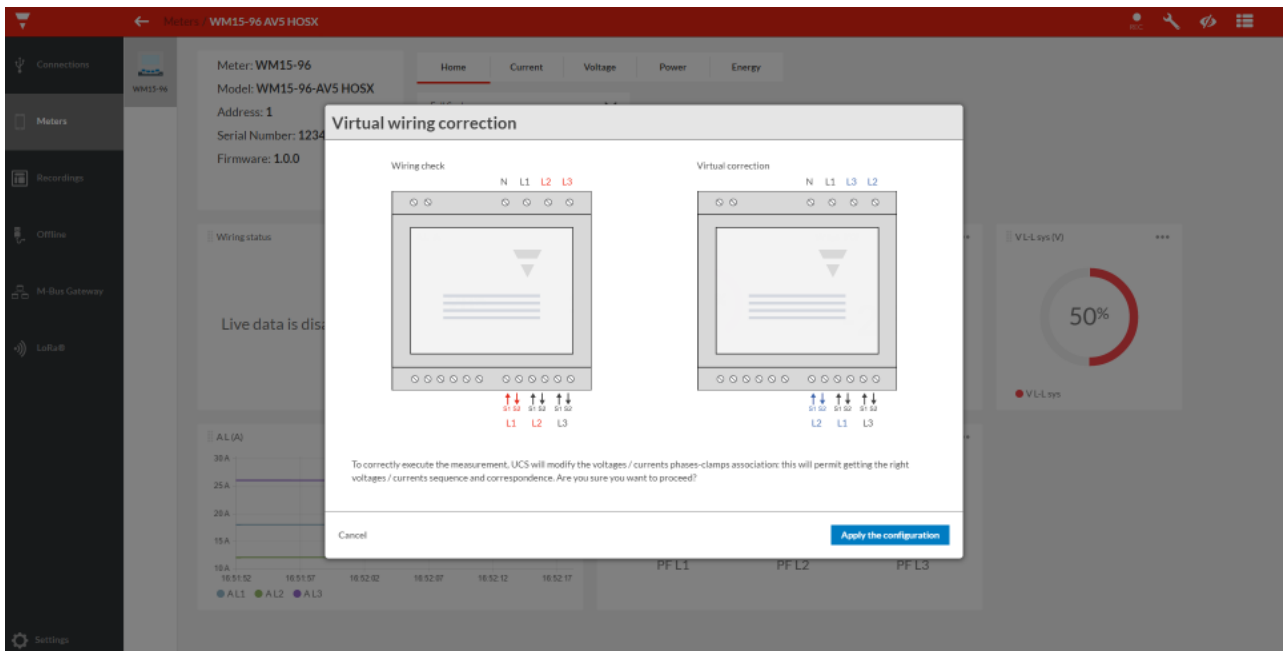
## Main features

- System and phase variables (V L-L, V L-N, A, W/var, VA, PF, Hz)
- Current and power (kW/kVA) demand calculation
- Simplified 4 push buttons user interface
- Optical port for easy configuration and diagnostic via OptoProg
- Digital output for pulse transmission or alarm
- Optional RS485 Modbus RTU or M-Bus (100 ms data refresh)
- Continuous sampling of each voltage and current
- Backlit matrix LCD display
- MID certified version
- cULus approved (UL 61010)
- Compliant with IEC/EN61557-12 performance requirements (active power and active energy)

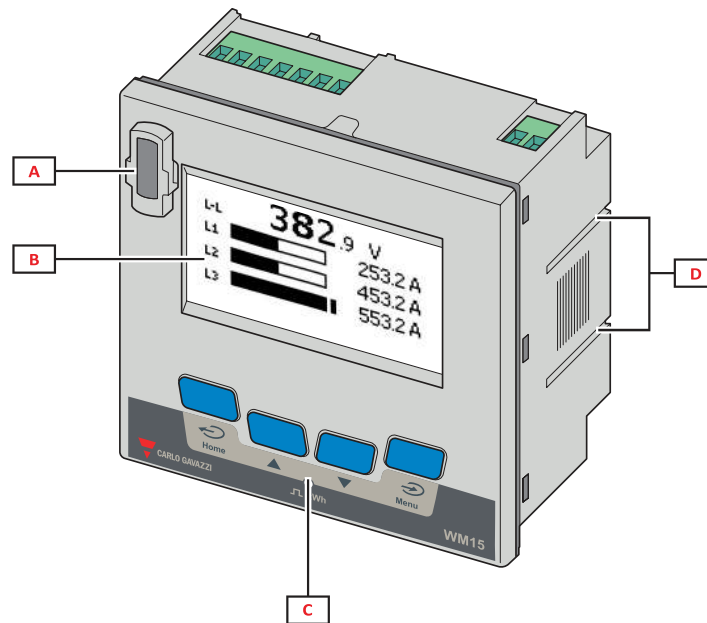
## UCS software and UCS Mobile application

- Free download: UCS desktop from Carlo Gavazzi website, UCS Mobile from Google Play Store
- Configuration via OptoProg (via Bluetooth) or RS485 from PC (via UCS desktop) or Android mobile device (via UCS Mobile)
- Setups can be saved offline for serial programming with a single command
- Real time data view for testing and diagnostics
- Notification of possible wiring errors and display of the corrective steps, reassignment of the correct association of the phases or the direction of the currents via software control.





## Structure



**Fig. 1 Front**

Area	Description
A	Optical port for easy programming and diagnostic via Optoprog
B	Matrix LCD display
C	Mechanical push buttons
D	Grooves for lateral brackets

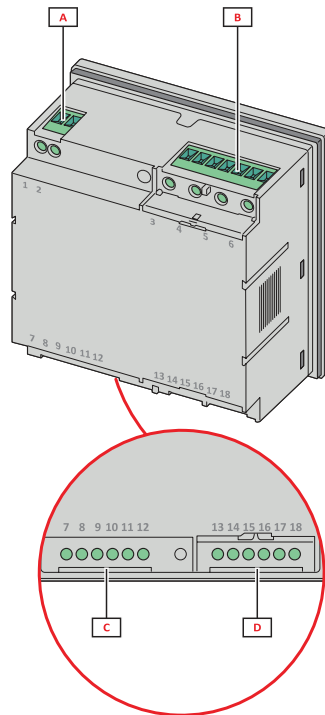


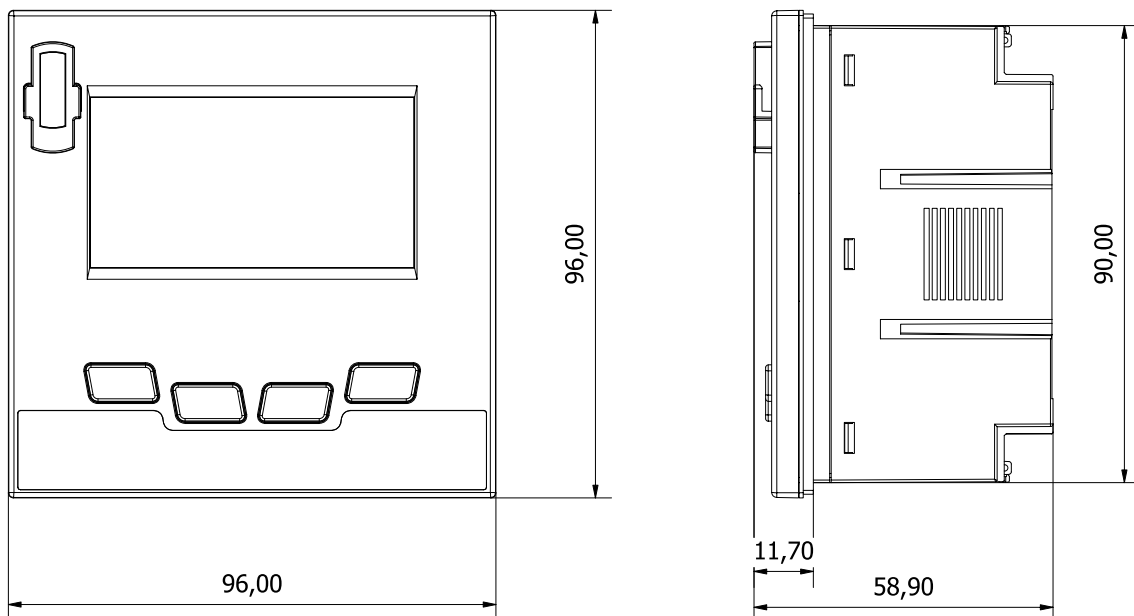
Fig. 2 Back

Area	Description
A	Power supply: auxiliary version (non-MID models only)
B	3-phase voltage input
C	RS485 or M-Bus port + digital output
D	3-phase current inputs

## Features

### General

<b>Material</b>	Housing: PC/ABS (UL94 V1) Transparent cover: PC (UL94 V2)
<b>Protection degree</b>	Front: IP51 Terminals: IP20
<b>Terminals</b>	Screw fixed terminal block, min:0.05; max: 2.5 mm <sup>2</sup>
<b>Overvoltage category</b>	Cat. III
<b>Pollution degree</b>	2
<b>Mounting</b>	Panel 96 x 96
<b>Weight</b>	280 g



### Environmental specifications

<b>Operating temperature</b>	From -25 to +55 °C/from -13 to +131 °F
<b>Storage temperature</b>	From -25 to +70 °C/from -13 to 158 °F
<b>Electromechanical environmental class</b>	E2
<b>Mechanical environmental class</b>	M2




NOTE: R.H. < 90 % non-condensing @ 40 °C / 104 °F.

## Input and output insulation

Type	Power supply (AV5 3H) [kV]	Measurement inputs [kV]	Digital output [kV]	RS485 serial port/M-Bus [kV]
Power supply (AV5 3H)	-	Base	Double/Reinforced	Double/Reinforced
Measurement inputs	Base	-	Double/Reinforced	Double/Reinforced
Digital output	Double/Reinforced	Double/Reinforced	-	Functional (100 V ac/dc)
RS485 serial port/M-Bus	Double/Reinforced	Double/Reinforced	Functional (100 V ac/dc)	-

According to: EN 61010-1, EN 50470-1 (MID). Overvoltage category III. Pollution degree 2.

## Compatibility and conformity

Directives	2014/32/EU (MID) 2014/35/EU (LVT - Low Voltage) 2014/30/EU (EMC - Electro Magnetic Compatibility) 2011/65/EU (Electric-electronic equipment hazardous substances)
Standards	Electromagnetic compatibility (EMC) - emissions and immunity: EN 62052-11; EN 50470-1 (MID) Electrical safety: EN 61010-1, EN 50470-1 (MID) Metrology: EN62053-21, EN62053-23, IEC61557-12, EN 50470-3 (MID), IEC/EN61557-12 (active power and active energy, MID models only) Pulse output: IEC 62053-31
Approvals	  

## Electrical specifications

Electrical system	
Managed electrical system	Single-phase (2-wire) Two-phase (3-wire) Three-phase with neutral (4-wire) Three-phase without neutral (3-wire) Wild leg system (three-phase, four-wire delta)
MID managed electrical system	Three-phase with neutral (4-wire) Three-phase without neutral (3-wire) (ARON)
Voltage inputs - MID	
Voltage connection	Direct
Rated voltage L-N	230 V
Rated voltage L-L	400 V
Voltage tolerance	From 0.8 to 1.15 Un
Overload	Continuous: 1.5 Un max
Input impedance	Refer to "Power supply"
Frequency	50 Hz

Voltage inputs Non MID models		
	AV5 3X	AV5 3H
<b>Voltage connection</b>	Direct	
<b>Rated voltage L-N (from Un min to Un max)</b>	120 to 240 V	120 to 347 V
<b>Rated voltage L-L (from Un min to Un max)</b>	208 to 415 V	208 to 600 V
<b>Voltage tolerance</b>	From 0.8 to 1.15 Un	
<b>Overload</b>	Continuous: 1.5 Un max	
<b>Input impedance</b>	Refer to "Power supply"	>1600 k $\Omega$
<b>Frequency</b>	From 45 to 65 Hz	

**Note:** for MID versions the voltage range is limited to 3x230 (400) V, frequency to 50Hz.

NOTE: WM15 can also be installed in a wild leg system (three phases, four delta wires), where one of the phase-neutral voltages is higher than the other two.

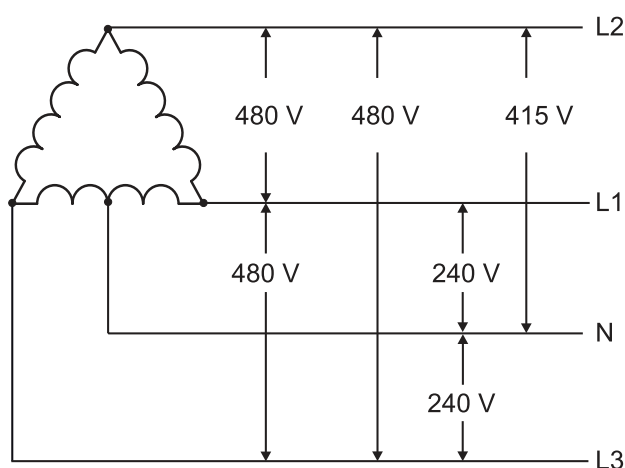


Fig. 3 AV5 3H

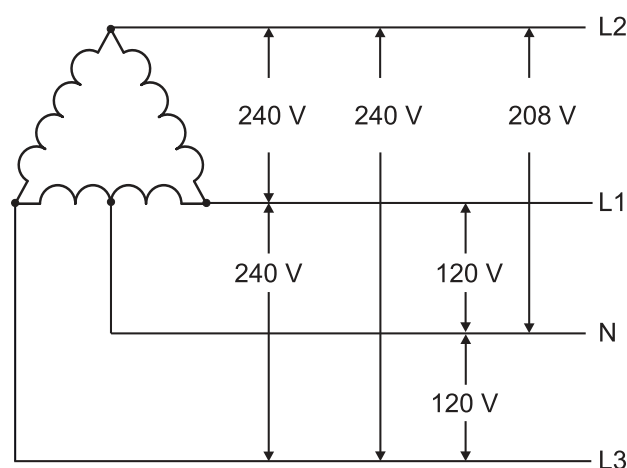


Fig. 4 AV5 3X, AV5 3H

Current inputs	
<b>Current connection</b>	Via CT
<b>CT transformation ratio</b>	2000 max
<b>Rated current (In)</b>	5 A
<b>Minimum current (Imin)</b>	0.05 A
<b>Maximum current (Imax)</b>	6 A
<b>Start-up current (Ist)</b>	10 mA
<b>Overload</b>	For 500 ms: 20 Imax (120 A)
<b>Input impedance</b>	< 0.2 VA
<b>Crest factor</b>	3
<b>Measurement type</b>	by means of internal shunts non mutually insulated (AV5 3X) by means of internal CT (AV5 3H)

## Power supply

	AV5 3X	AV5 3H
<b>Type</b>	Self power supply	Auxiliary power supply from 120 to 240 V ac/dc
<b>Frequency</b>	50/60 Hz	



## Measurements

Method	TRMS measurements of distorted waveforms
--------	--

## Available measurements

Active energy	Unit	System	Phase
Imported (+) Total	kWh+	●	●
Imported (+) partial	kWh+	●	-
Exported (-) Total	kWh-	●	-
Exported (-) partial	kWh-	●	-

Reactive energy	Unit	System	Phase
Imported (+) Total	kvarh+	●	-
Imported (+) partial	kvarh+	●	-
Exported (-) Total	kvarh-	●	-
Exported (-) partial	kvarh-	●	-

Apparent energy	Unit	System	Phase
Total	kVAh	●	-
Partial	kVAh	●	-

Run hour meter	Unit	System	Phase
Total (kWh+)	hh:mm	●	-
Partial (kWh+)	hh:mm	●	-
Total (kWh-)	hh:mm -	●	-
Partial (kWh-)	hh:mm -	●	-

Electrical variable	Unit	System	Phase
Voltage L-N	V	●	●
Voltage L-L	V	●	●
Current	A	●	●
DMD	A	-	●
DMD MAX	A	-	●
Active power	kW	●	●
DMD	kW	●	-
DMD MAX	kW	●	-
Apparent power	kVA	●	●
DMD	kVA	●	-
DMD MAX	kVA	●	-
Reactive power	kvar	●	●
Power factor	PF	●	●
Frequency	Hz	●	-
THD Current*	THD A %	-	●
THD Voltage L-N*	THD L-N %	-	●
THD Voltage L-L*	THD L-L %	-	●

\* Up to 15<sup>th</sup> harmonic

NOTE: the available variables depend on the type of system set.

Total imported active energy (kWh TOT) is the only MID certified meter. Apparent energy, reactive energy and exported active energy are not MID certified. Partial meters are not MID certified.

All the variables calculated by the meter are referred to the primary current of the current transformer.

## Energy metering

For every measuring interval time, the energies of the single phases are summed; according to the sign of the result, the positive (kWh+) or negative totalizer (kWh-) is increased.

Example:

P L1= +2 kW, P L2= +2 kW, P L3= -3 kW

Integration time = 1 hour

+kWh=(+2+2-3)x1h=(+1)x1h=1 kWh

-kWh=0 kWh

## Measurement accuracy

Current	Standard	05 option
From 0.05 In to I <sub>max</sub>	± 0.5% rdg	± 0.3% rdg
From 0.01 In to 0.05 In	± 1% rdg	± 0.6% rdg

Phase-phase voltage	Standard	05 option
From Un min -20% to Un max +15%	± 0.5% rdg	± 0.2% rdg

Phase-neutral voltage	Standard	05 option
From Un min -20% to Un max +15%	± 0.5% rdg	± 0.2% rdg

Active and apparent power	Standard	05 option
From 0.05 In to I <sub>max</sub> (PF=1)	± 1% rdg	± 0.5% rdg
From 0.05 In to I <sub>max</sub> (PF=0.5L - 0.8C)	± 1% rdg	-
From 0.01 In to 0.05 In (PF=1)	± 1.5% rdg	± 1% rdg
From 0.1 In to I <sub>max</sub> (PF=0.5L - 0.8C)	-	± 0.6% rdg
From 0.02 In to 0.1 In (PF=0.5L - 0.8C)	-	± 1% rdg

Reactive power	Standard	05 option
From 0.1 In to I <sub>max</sub> (sinφ=0.5L - 0.5C)	± 2% rdg	± 2% rdg
From 0.05 In to I <sub>max</sub> (sinφ=1)		
From 0.05 In to 0.1 In (sinφ=0.5L - 0.5C)	± 2.5% rdg	± 2.5% rdg
From 0.02 In to 0.05 In (PF=1)		
Active energy	Class 1 EN62053-21, Class B EN50470-3 (MID)	Class 0.5S 62053-22
Reactive energy	Class 2 (EN62053-23)	Class 2 (EN62053-23)

Frequency	Standard	05 option
From 45 to 65 Hz	± 0.1% rdg	± 0.1% rdg

Measurement accuracy according to IEC/EN61557-12 (MID models)	
Active power	Performance class 1
Active energy	Performance class 2

## Measurement resolution

Variable	Display resolution	Resolution by Modbus RTU	Resolution by M-Bus
Energy	0.01 kWh/kvarh/kVAh	0.001 kWh/kvarh/kVAh	0.001 kWh/0.1 kvarh
Power	0.1 kW/kvar/kVA	0.1 W/var/VA	
Current*	0.1 A	0.001 A	
Voltage	0.1 V		
Frequency	0.1 Hz	0.001 Hz	
THD	0.01 %		
Power factor	0.01		

\*Note: value referred to CT ratio =1

## Display

Type	Matrix 128x64 dots
Refresh time	500 ms
Description	Backlit LCD
Variable readout	Instantaneous: 5+1 dgt Power factor: 1+2 dgt Energy: 8+2 dgt

## LED

Front	Red. Pulse weight: proportional to energy consumption and depending on the CT ratio (16 Hz maximum frequency):	
	<b>Weight (kWh per pulse)</b>	<b>CT ratio</b>
	0.001	≤ 7
	0.01	From 7.1 to 70
	0.1	From 70.1 to 700
1	From 700.1 to 2000	

## Digital outputs

### Digital output

<b>Connection type</b>	Screw terminals
<b>Maximum number of outputs</b>	1
<b>Type</b>	Opto-mosfet
<b>Function</b>	Pulse output or alarm output
<b>Features</b>	$V_{ON}$ 2.5 V ac/dc, max 100 mA $V_{OFF}$ 42 V ac/dc
<b>Configuration parameters</b>	Output function (pulse/alarm) Pulse weight (from 0.001 to 10 kWh per pulse) Pulse duration (30 or 100 ms) Output normal status (NO or NC)
<b>Configuration mode</b>	Via keypad or UCS software

## Communication ports

### RS485 port

<b>Protocol</b>	Modbus RTU
<b>Devices on the same bus</b>	Max 160 (1/5 unit load)
<b>Communication type</b>	Multidrop, bidirectional
<b>Connection type</b>	2 wires
<b>Configuration parameters</b>	Modbus address (from 1 to 247) Baud rate (9.6 / 19.2 / 38.4 / 115.2 kbps) Parity (None/ Odd/ Even)
<b>Refresh time</b>	≤ 100 ms
<b>Configuration mode</b>	Via keypad or UCS software

### Optical port

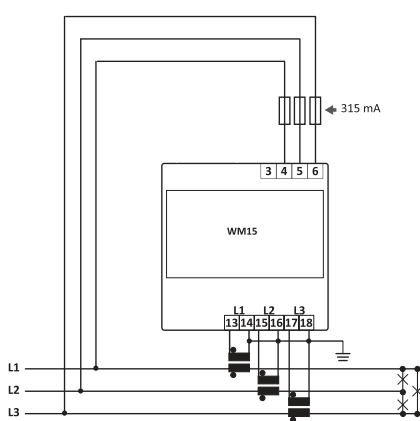
<b>Compatible accessories</b>	OptoProg
<b>Function</b>	Configuration and diagnostic via UCS Mobile app or UCS software

### M-Bus

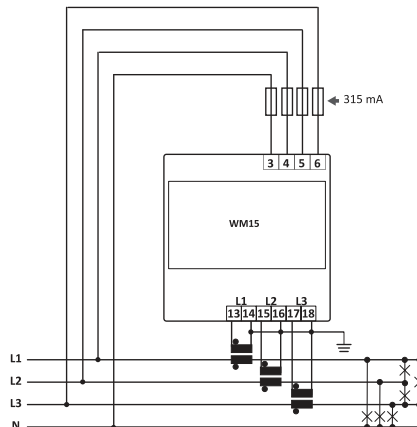
<b>Protocol</b>	M-Bus according to EN13757-3:2013
<b>Devices on the same bus</b>	Max 250 (1 unit load)
<b>Connection type</b>	2 wires
<b>Configuration parameters</b>	Primary address (1 to 250) Baud rate (0.3/ 2.4 / 9.6 kbps)
<b>Refresh time</b>	≤ 100 ms
<b>Configuration mode</b>	Via keypad or UCS software

# Connection Diagrams

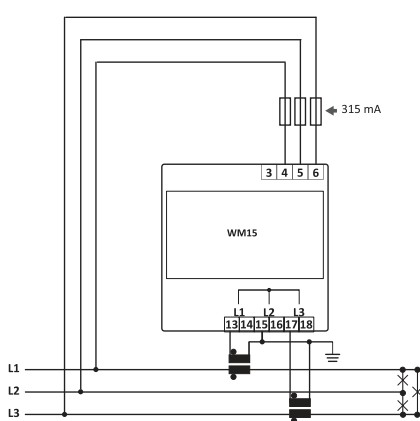
## Non MID models



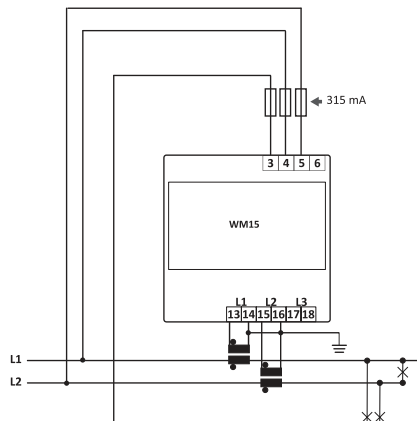
**Fig. 5** Three-phase without neutral (3-wire)



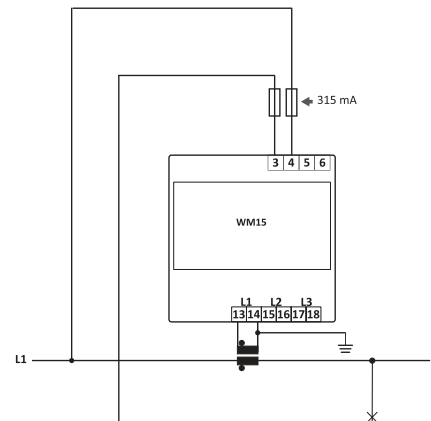
**Fig. 6** Three-phase with neutral (4-wire)



**Fig. 7** Three-phase without neutral (3-wire)



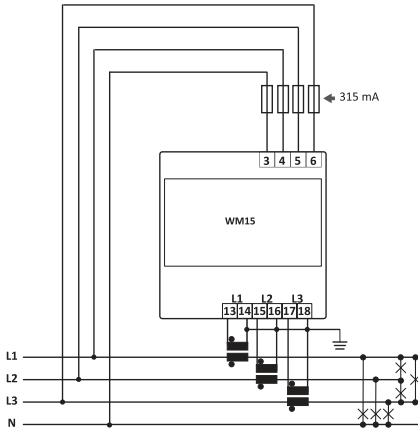
**Fig. 8** Two-phase system with neutral (3-wire)



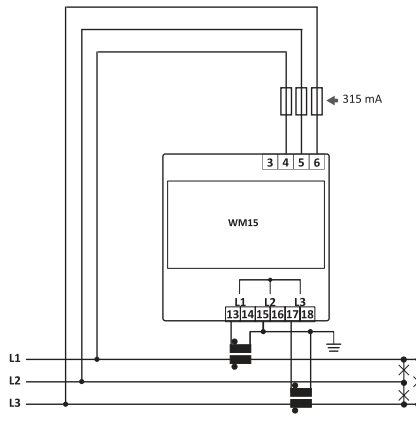
**Fig. 9** Single-phase (2-wire)

Note: current transformers must be grounded or not according to national regulations.

## MID models



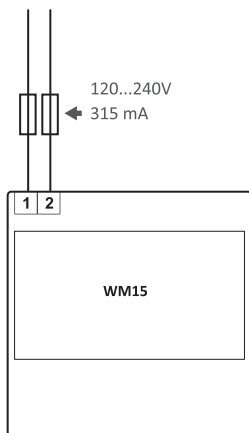
**Fig. 10** Three-phase with neutral (4-wire)



**Fig. 11** Three-phase without neutral (3-wire) - ARON

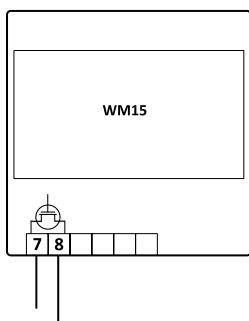
Note: current transformers must be grounded or not according to national regulations.

## Power supply (non MID models)



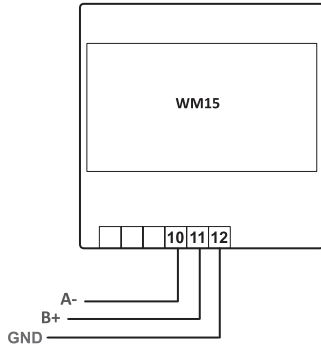
**Fig. 12** Auxiliary power supply (H)

## Output

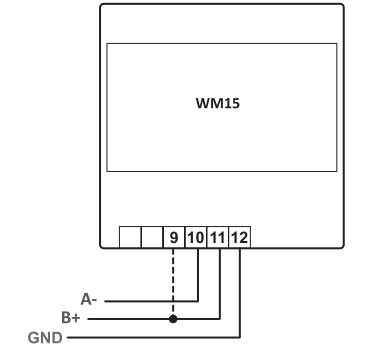


**Fig. 13** Digital output

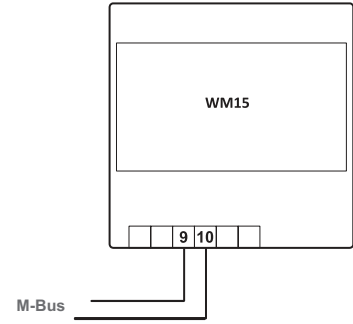
## Communication



**Fig. 14** RS485 port



**Fig. 15** Last device on RS485



**Fig. 16** M-Bus

## References

Order code



WM15 96 AV5 3 X OX

### Self power supply, static output

Enter the code option instead of

Code	Options	Description
W	-	-
M	-	-
1	-	-
5	-	-
9	-	-
6	-	-
A	-	-
V	-	-
5	-	-
3	-	-
X	-	Self power supply. Voltage inputs 415 V LL
OX	-	Digital output only
<input type="checkbox"/>	X	Non MID, accuracy class 1 kWh
	PFB	MID (3P and 3P.n), accuracy class B kWh
	X05	MID (3P and 3P.n), accuracy class 0.5 S kWh

- PFB: only the total positive totalizer (kWh+) is certified according to MID. The negative energy totalizer is available but not certified according to MID.




 WM15 96 AV5 3 X OM  

### Self power supply, static output, M-Bus port

 Enter the code option instead of 

Code	Options	Description
W	-	-
M	-	-
1	-	-
5	-	-
9	-	-
6	-	-
A	-	-
V	-	-
5	-	-
3	-	-
X	-	Self power supply. Voltage inputs 415 V LL
OM	-	Digital output and M-Bus
<input type="checkbox"/>	X	Non MID, accuracy class 1 kWh
	PFB	MID (3P and 3P.n), accuracy class B kWh

- PFB: only the total positive totalizer (kWh+) is certified according to MID. The negative energy totalizer is available but not certified according to MID.

WM15 96 AV5 3 X OS  **Self power supply, static output, RS485 Modbus RTU**Enter the code option instead of 

Code	Options	Description
W	-	-
M	-	-
1	-	-
5	-	-
9	-	-
6	-	-
A	-	-
V	-	-
5	-	-
3	-	-
X	-	Self power supply. Voltage inputs 415 V LL
OS	-	Digital output and RS485
<input type="checkbox"/>	X	Non MID, accuracy class 1 kWh
	PFB	MID (3P and 3P.n), accuracy class B kWh
	X05	Non MID, accuracy class 0.5S kWh
	XCN	Non MID, accuracy class 1 kWh, Chinese user interface
	XKR	Non MID, accuracy class 1 kWh, Korean user interface
	XCN05	Non MID, accuracy class 0.5S kWh, Chinese user interface
	XKR05	Non MID, accuracy class 0.5S kWh, Korean user interface

- PFB: only the total positive totalizer (kWh+) is certified according to MID. The negative energy totalizer is available but not certified according to MID.

WM15 96 AV5 3 H OS 

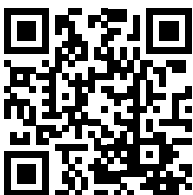
### Auxiliary power supply, static output, RS485 Modbus RTU

Enter the code option instead of

Code	Options	Description
W	-	-
M	-	-
1	-	-
5	-	-
9	-	-
6	-	-
A	-	-
V	-	-
5	-	-
3	-	-
H	-	Auxiliary power supply, from 120 to 240 V ac/dc. Voltage inputs 600 V LL
OS	-	Digital output and RS485
<input type="checkbox"/>	X	Non MID, accuracy class 1 kWh
	XCN	Non MID, accuracy class 1 kWh, Chinese user interface

### CARLO GAVAZZI compatible components

Purpose	Component name/part number	NOTES
Quickly configure several analyzers via optical interface	OptoProg	See relevant datasheet
Configure analyzer via desktop application	UCS software	Available for free download at: <a href="http://www.productselection.net">www.productselection.net</a>
Configure analyzer via Android application	UCS Mobile	Available for free download at: <a href="https://play.google.com/store">https://play.google.com/store</a>
Aggregate, store and transmit data to other systems	UWP 3.0	See relevant datasheet



COPYRIGHT ©2022  
Content subject to change. Download the PDF: [www.productselection.net](http://www.productselection.net)