



GainAMP 2 click

PID: MIKROE-2859

Weight: 28 g

GainAMP 2 click is a 6-channel programmable gain amplifier, used to amplify signals on any of the 6 non-inverting input channels up to 32x, in eight discrete steps. The gain can be set via the SPI communication interface. The click has a high signal to noise ratio, a good bandwidth, and very low gain error. These features make it an ideal solution for amplifying sensitive low signals from various sources.

Due to its low noise compared to most of the ADCs, it can be used to adjust the dynamic range of the ADC input signal. The GainAMP 2 can also be used to expand the analog input capacity of the MCU with the additional gain control for each source. This click can be easily daisy-chained if more than six inputs are needed - or to achieve other gain ratios, not possible with a single device.

How it works

GainAMP 2 click uses the MCP6S21, a rail-to-rail I/O, low noise programmable gain amplifier (PGA) from Microchip. This integrated circuit features six multiplexed non-inverting inputs, with a gain that can be programmed via the SPI interface for each input individually. The channels CH0 to CH5 are the six input channels, connected to the external signal sources. The internal multiplexer selects the channel that is gained and sent to the output pin. The gain stage of the MCP6S21 has eight different discrete steps of gain: 1, 2, 4, 5, 8, 10, 16 and 32V/V.

The rail-to-rail inputs and outputs accept voltage levels up to VCC with no distortions or phase shifting. The output voltage is offset by the resistor ladder network on the output stage and the voltage on the voltage reference pin.

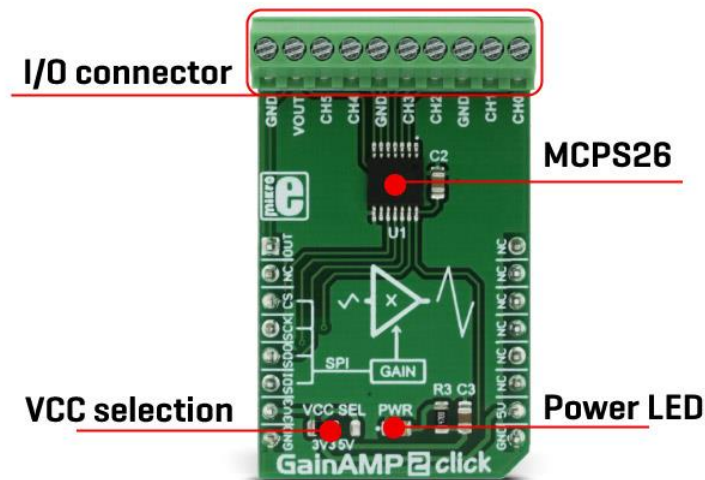

Besides the VOUT pin on the 10 pole I/O connector, the MCP6S21 output pin is also routed to the AN pin of the mikroBUS™ so it can be used as the input signal for the ADC. This allows the amplified signal to be easily digitalized and processed by the MCU. Using the click board in this configuration effectively turns the GainAMP 2 click into an analog port expander with the selectable gain on its inputs.

The MCP6S21 device can be put in a shutdown mode by setting the appropriate bits of the internal register via the SPI interface. While in shutdown mode, the power consumption is minimal. The device stays in the shutdown mode until a valid command is received via the SPI. While in the shutdown mode, device remembers states of the internal registers, so when its awoken, it will resume working as before. The internal registers can be easily accessed by using MikroElektronika library functions. More information about the registers and their settings can be found in the MCP6S21 datasheet.

GainAMP 2 click can work with both 3.3V and 5V, which can be selected by the onboard SMD jumper. GainAMP 2 click has a 10 pole I/O connector, so the connection of the external signals can be easily done.

Specifications

Type	Amplifier
Applications	Used for low and sensitive signal amplification, such as the signals from various sensors, can be used as an analog input expander for a MCU or as an input amplifying stage of the ADC.
On-board modules	MCP6S26 - rail-to-rail I/O, low noise programmable gain amplifier
Key Features	Six multiplexed non-inverting analog input channels, with programmable gain, rail-to-rail inputs and outputs with no phase shifting and very good bandwidth, low THD, and great SNR
Interface	Analog,SPI
Input Voltage	3.3V or 5V
Click board size	M (42.9 x 25.4 mm)

Pinout diagram

This table shows how the pinout on **GainAMP 2 click** corresponds to the pinout on the mikroBUS™ socket (the latter shown in the two middle columns).

Notes	Pin					Pin	Notes
Signal Output	VOUT	1	AN	PWM	16	NC	
	NC	2	RST	INT	15	NC	
SPI Chip Select	CS	3	CS	RX	14	NC	
SPI Clock	SCK	4	SCK	TX	13	NC	
SPI Slave Data Out	SDO	5	MISO	SCL	12	NC	
SPI Slave Data In	SDI	6	MOSI	SDA	11	NC	
Power Supply	+3.3V	7	3.3V	5V	10	+5V	Power supply

Ground	GND	8	GND	GND	9	GND	Ground
--------	------------	---	-----	-----	---	------------	--------

GainAMP 2 click electrical specifications

Description	Min	Typ	Max	Unit
Input voltage range	-0.3		VCC+0.3	V
Frequency response (-3dB)	2		12	MHz
Total harmonic distortion (THD)	0.0015		0.036	%
Maximum SPI SCK frequency			10	MHz

Onboard settings and indicators

Label	Name	Default	Description
LD1	PWR	-	Power LED indicator
JP1	VCC SEL	3V3	Power supply voltage selection: Left position 3V3, right position 5V
CN1	CN1	-	I/O connector

PINS on 10 pole I/O terminal

Label	Name
PIN1	Input channel 0
PIN2	Input channel 1
PIN4	Input channel 2
PIN5	Input channel 3
PIN7	Input channel 4
PIN8	Input channel 5
PIN9	Output
PIN3, PIN6, PIN10	GND

Software Support

We provide a library for GainAMP 2 click on our LibStock page, as well as a demo application (example), developed using MikroElektronika compilers. The demo can run on all the main MikroElektronika development boards.

Library Description

The library carries a single function which allows complete control over GainAMP 2 click.

Key functions

gainamp2_writeCommand- Writes desired command data

Examples Description

The demo application shows the simplicity of usage.
The application is composed of two sections :

- System Initialization - Initializes CS pin as output and SPI module
- Application Initialization - Setups GainAMP 2 click channel 4 to amplify the signal 4 times

```
applicationInit()  
{  
    gainamp2_spiDriverInit( (T_GAINAMP2_P)&_MIKROBUS1_GPIO,  
(T_GAINAMP2_P)&_MIKROBUS1_SPI );  
  
    // SETUP GAIN +4 on CHANNEL  
    gainamp2_writeCommand( _GAINAMP2_WRITE_INS | _GAINAMP2_CH, _GAINAMP2_CH4  
);  
    gainamp2_writeCommand( _GAINAMP2_WRITE_INS | _GAINAMP2_GAIN,  
_GAINAMP2_GAIN_4X );  
  
    mikrobus_logWrite( "Channel 4 - amplified 4x", _LOG_LINE );  
}
```

The full application code, and ready to use projects can be found on our LibStock page.

Additional notes and information

Depending on the development board you are using, you may need USB UART click, USB UART 2 click or RS232 click to connect to your PC, for development systems with no UART to USB interface available on the board. The terminal available in all MikroElektronika compilers, or any other terminal application of your choice, can be used to read the message.

mikroSDK

This click board is supported with mikroSDK, the MikroElektronika Software Development Kit. To download mikroSDK visit LibStock. For more information about SDK, visit the official page.

Downloads

LibStock: GainAMP 2 click

mikroBUS™ standard specifications

MCP6S26 datasheet

GainAMP 2 click schematic

