

DO NOT
SCALE FROM
THIS PRINT

DESIGNED & DIMENSIONED
IN INCHES[MILLIMETERS]

PRF06-P-C-EP-284-SS

SERIES
-06: NTPE

GENDER
-P: PLUG

TYPE
-C: CABLE

TERMINATION
-S: SOLDER CLAMP

ORIENTATION
-S: STRAIGHT

CABLE TYPE
-284: MICRO-COAX UFB311A

FINISH
-EP: 50µ" EXTRA HEAVY GOLD
CENTER CONTACT, PASSIVATED
OUTER CONTACT

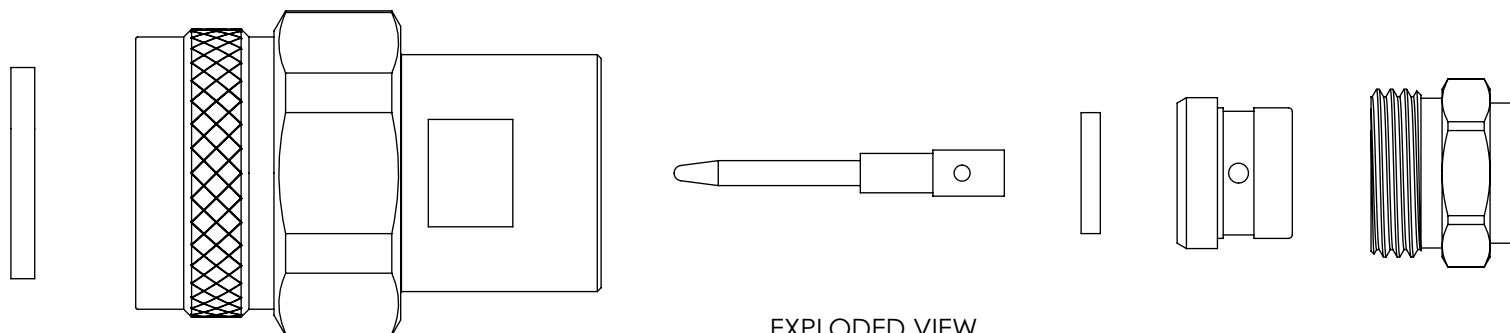
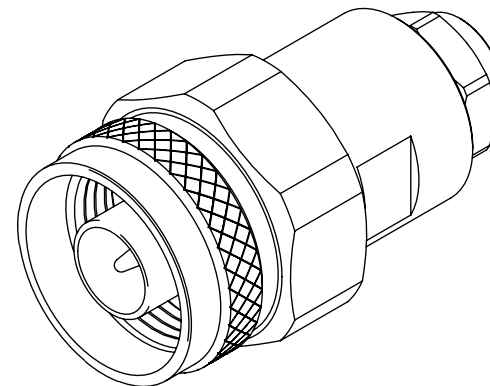
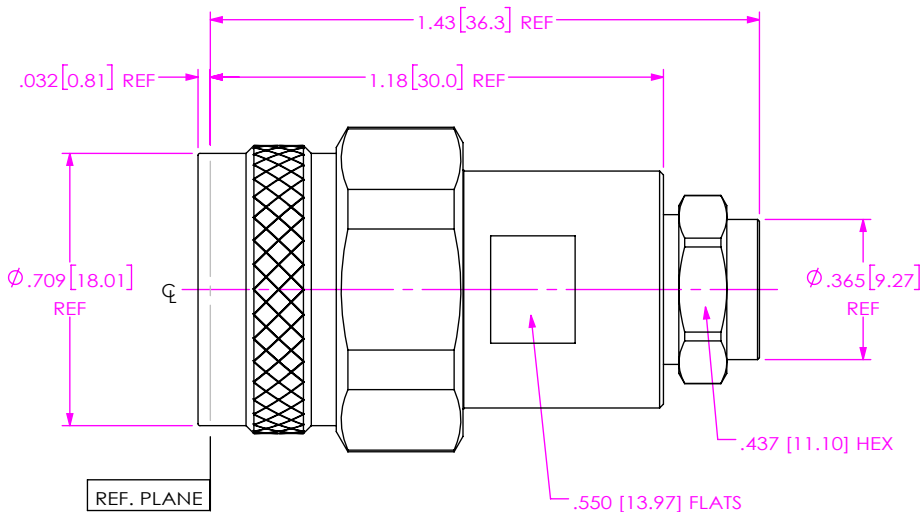

EXPLODED VIEW
NOT TO SCALE
(FOR CLARITY ONLY)

NOTES:

- MATERIAL:**
BODY, CLAMP NUT & COUPLING NUT: STAINLESS STEEL.
CONTACT & LOCK RING: BeCu.
GASKET: SILICONE RUBBER.
INSULATOR: TEFLON FLUOROCARBON.
FORWARD DIELECTRIC & DIELECTRIC STOP: ULTEM 1000.
SOLDER FERRULE: BRASS ALLOY 360.
- FINISH:**
BODY, CLAMP NUT & COUPLING NUT: PASSIVATED.
SOLDER FERRULE & CONTACT: GOLD OVER NICKEL PLATE,
50 µIN MIN GOLD OVER 50 µIN MIN NICKEL.
- PCI P/N: 3397.

UNLESS OTHERWISE SPECIFIED,
DIMENSIONS ARE IN INCHES.
TOLERANCES ARE:
DECIMALS ANGLES
.XX: ±.01 [0.3] 1°
.XXX: ±.005 [0.13]
.XXXX: ±.0005 [0.013]

PROPRIETARY NOTE
THIS DOCUMENT CONTAINS CONFIDENTIAL AND PROPRIETARY INFORMATION AND ALL DESIGN, MANUFACTURING, REPRODUCTION, USE, PATENT RIGHTS AND SALES RIGHTS ARE EXPRESSLY RESERVED BY SAMTEC, INC. THIS DOCUMENT SHALL NOT BE DISCLOSED, IN WHOLE OR PART, TO ANY UNAUTHORIZED PERSON OR ENTITY NOR REPRODUCED, TRANSFERRED OR INCORPORATED IN ANY OTHER PROJECT IN ANY MANNER WITHOUT THE EXPRESS WRITTEN CONSENT OF SAMTEC, INC.



520 PARK EAST BLVD, NEW ALBANY, IN 47150
PHONE: 812-944-6733 FAX: 812-948-5047
e-Mail: info@SAMTEC.com code 55322

DO NOT SCALE DRAWING

SHEET SCALE: 2:1

DESCRIPTION: N PLUG, SOLDER CLAMP FOR MICRO-COAX UFB311A CABLE

DWG. NO. PRF06-P-C-EP-284-SS

BY: EVE L 07/09/2021 SHEET 1 OF 2

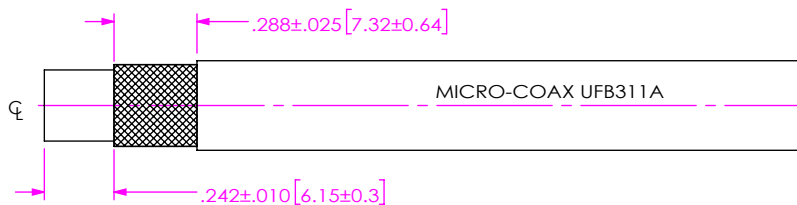

1A. TRIM CABLE TO EXPOSE DIELECTRIC AND BRAID AS SHOWN.

IN-PROCESS 1

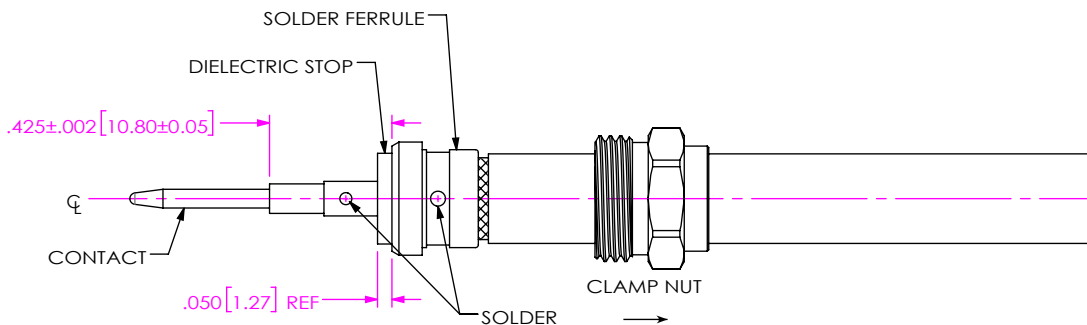

- 2A. SLIDE CLAMP NUT OVER CABLE AS SHOWN.
- 2B. INSERT CABLE INTO SOLDER FERRULE UNTIL BRAID SEATS. THEN SOLDER BRAIDS TO FERRULE WHERE SHOWN.
- 2C. TRIM CABLE DIELECTRIC FLUSH WITH FACE OF FERRULE.
- 2D. SLIDE DIELECTRIC STOP OVER CABLE CENTER CONDUCTOR AND SOLDER CONTACT FLUSH AGAINST STOP TO DIMENSION SHOWN.

IN-PROCESS 2

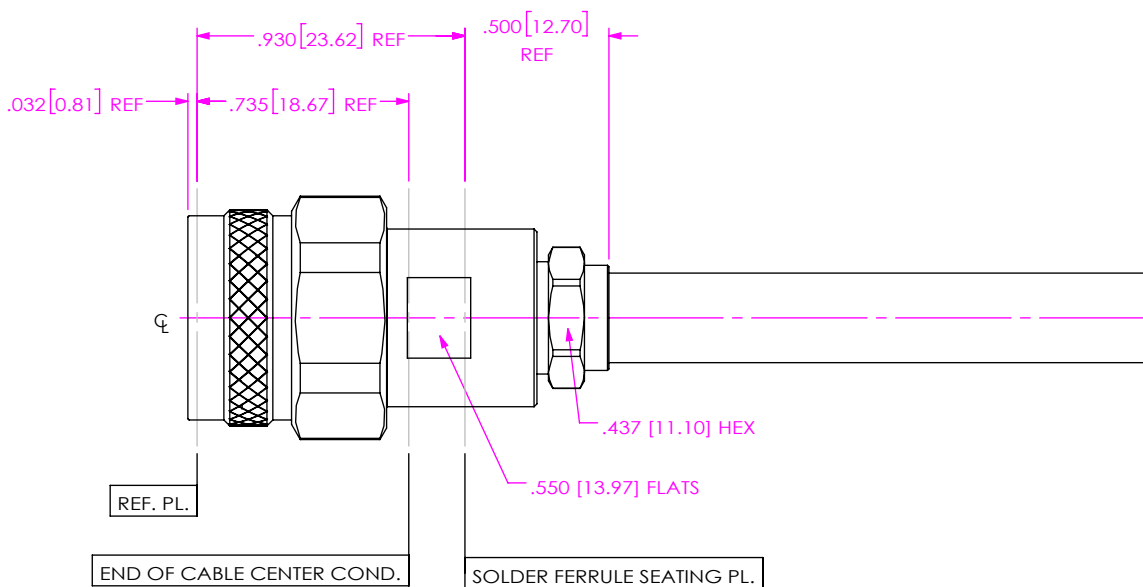

3A. INSERT CABLE/CONTACT SUB-ASSEMBLY INTO CONNECTOR UNTIL SEATED AND TIGHTEN CLAMP NUT TO 35-45 IN-LBS.

IN-PROCESS 3

<p>PROPRIETARY NOTE</p> <p>THIS DOCUMENT CONTAINS CONFIDENTIAL AND PROPRIETARY INFORMATION AND ALL DESIGN, MANUFACTURING, REPRODUCTION, USE, PATENT RIGHTS AND SALES RIGHTS ARE EXPRESSLY RESERVED BY SAMTEC, INC. THIS DOCUMENT SHALL NOT BE DISCLOSED, IN WHOLE OR PART, TO ANY UNAUTHORIZED PERSON OR ENTITY NOR REPRODUCED, TRANSFERRED OR INCORPORATED IN ANY OTHER PROJECT IN ANY MANNER WITHOUT THE EXPRESS WRITTEN CONSENT OF SAMTEC, INC.</p>	 <p>520 PARK EAST BLVD, NEW ALBANY, IN 47150 PHONE: 812-944-6733 FAX: 812-948-5047 e-Mail: info@SAMTEC.com code 55322</p>
<p>DO NOT SCALE DRAWING</p> <p>SHEET SCALE: 1.5:1</p>	<p>DESCRIPTION: N PLUG, SOLDER CLAMP FOR MICRO-COAX UFB311A CABLE</p> <p>DWG. NO. PRF06-P-C-EP-284-SS</p> <p>BY: EVE L 07/09/2021 SHEET 2 OF 2</p>