

Tous droits strictement réservés. Reproduction ou communication a des tiers interdite sous quelque forme que ce soit sans autorisation écrite du propriétaire. Propriété de © FCI ELECTRONICS. Droits de reproduction FCI ELECTRONICS INC.

Property of © FCI ELECTRONICS. Copyright FCI ELECTRONICS INC.



All rights strictly reserved. Reproduction or issue to third parties in any form whatever is not permitted without written authority from the proprietor. Property of © FCI ELECTRONICS. Copyright FCI ELECTRONICS INC.

Property of © FCI ELECTRONICS. Copyright FCI ELECTRONICS INC.

PRODUCT NO.  
0016521-XXXXXXX

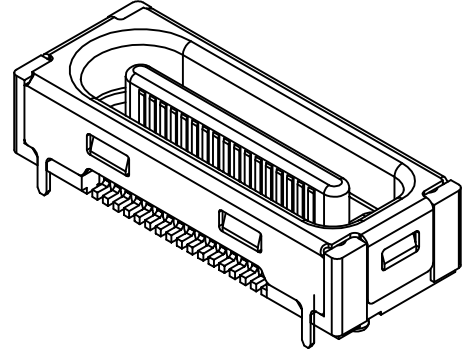
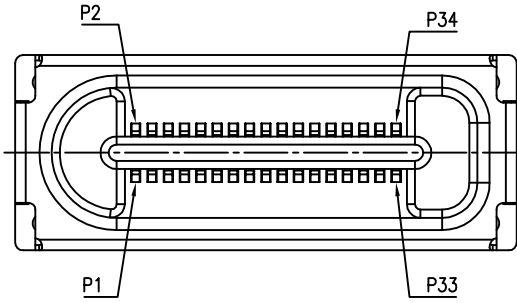

NOTE :  
 1. MATERIAL :  
 HOUSING : HIGH TEMPERATURE THERMOPLASTIC, UL 94 V-0 FLAME RETARDANT, BLACK. BURR 0.03 MAX.  
 TERMINAL : COPPER ALLOY.  
 PLATING SPEC. AS BELOW :  
 Ni 50u" UNDER PLATED.  
 Au 30u" OVER ZONE A. (ONE SIDE)  
 Sn 120u" OVER ZONE B.  
 SHIELD : STEEL, NICKEL PLATE 30u" ALL OVER.  
 2. PRODUCT PERFORMANCE PER SPEC. GS-12-205.  
 3. PRODUCT PACKAGING PER SPEC. GS-14-846.  
 4. PRODUCT DATE CODE :  
 X X X  
 WEEK  
 YEAR

5. PART NUMBER SCHEME :  
 10016521-X X X X X X X X  
 "LF"  
 PROFILE HEIGHT  
 1 | H= 4.3mm  
 SEE FIG 1  
 PACKAGING  
 2 | TAPE AND REEL  
 PIN NUMBER  
 034 | 34 PIN  
 PLASTIC COLOR  
 1 | BLACK

6. THIS PRODUCTS MEETS EUROPEAN UNION DIRECTIVE AND OTHER COUNTRY REGULATIONS AS DESCRIBED IN GS-22-008.

7. THE HOUSING WILL WITHSTAND EXPOSURE TO 260° PEAK TEMPERATURE FOR 10 SECONDS IN A CONVECTION INFRA-RED OR VAPOR PHASE REFLOW OVEN.

MATED PART	RECEPTACLE	MATING H = 11
PART NO.	10016521-103421LF	
PROFILE H	10.9	

FIG 1

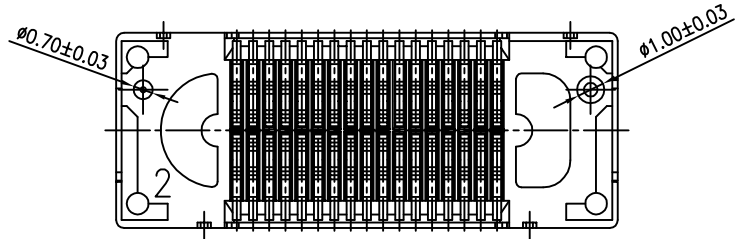
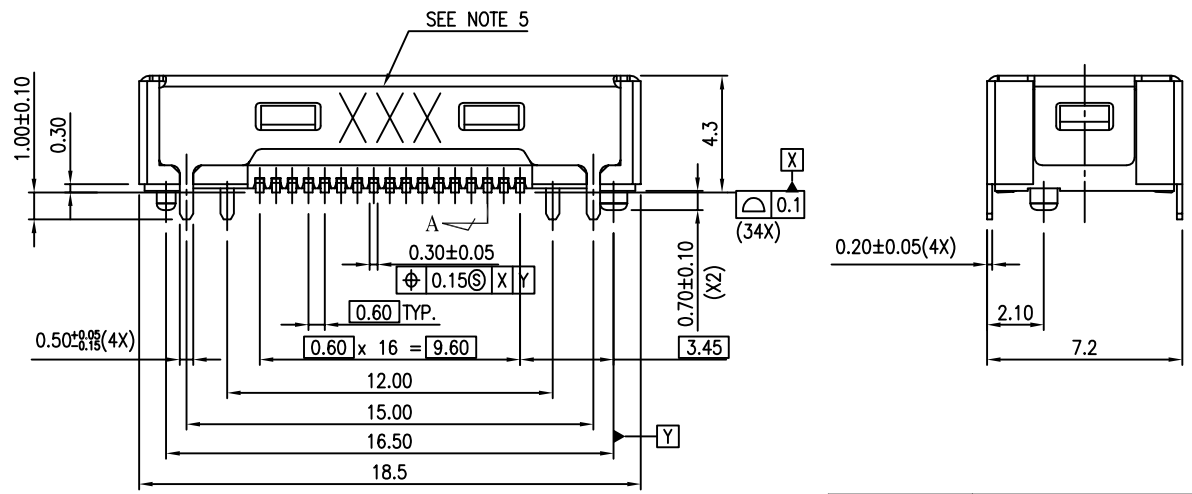

mat'l. code				tolerances unless otherwise specified				CUSTOMER COPY		FCI www.fciconnect.com	
ltr	ecn no	dr	date	linear	.X ± .5	projection	title	34P BTB DOCKING CONNECTOR PLUG ASSEMBLY		product family BOARD TO BOARD code	
A	T03-0412	RC	9/18/03		.XX ± .20		size				
B	T03-0571	LH	02/02/04		.XXX ± .100		dwg no	10016521		sheet 1 of 3	
C	0605-0174	LH	06/23/05	angles	0° ± 2°		scale				
D	0606-0452	CL	11/07/06	dr	Richard Chiu 8/01/03	mm	A3	5:1			
				enrg	Richard Chiu 8/01/03						
				chr	Paul Wang 8/01/03						
				appd	JENN TSAO 8/01/03						
sheet index	revision sheet	D	D								
		1	2								

Tous droits strictement réservés. Reproduction ou communication a des tiers interdite sous quelque forme que ce soit sans autorisation écrite du propriétaire. Propriété de © FCI ELECTRONICS. Droits de reproduction FCI ELECTRONICS INC.

All rights strictly reserved. Reproduction or issue to third parties in any form whatever is not permitted without written authority from the proprietor. Property of © FCI ELECTRONICS. Copyright FCI ELECTRONICS INC.

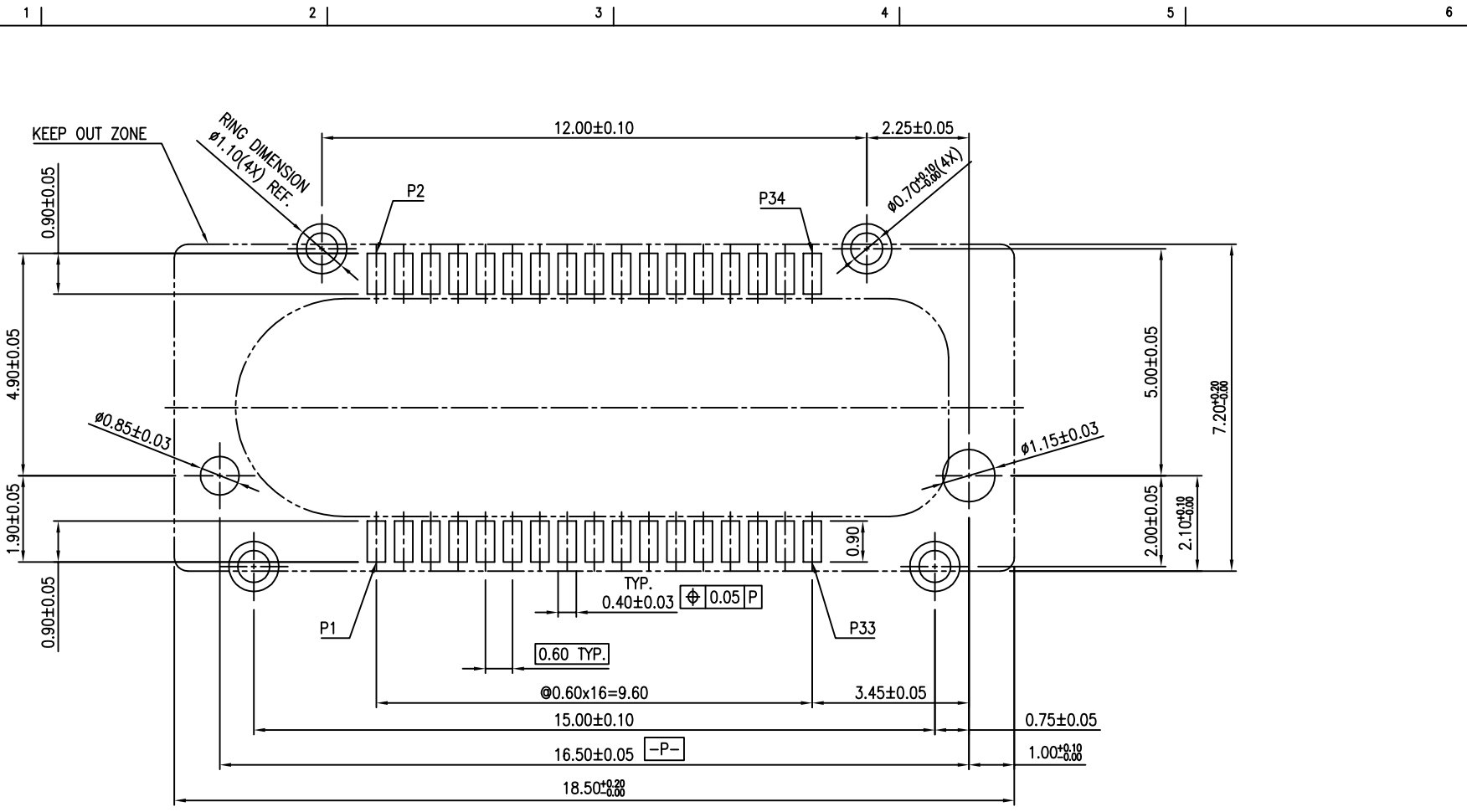

RECOMMENDED PCB LAYOUT

mat'l. code				tolerances unless otherwise specified				CUSTOMER COPY		FCI www.fciconnect.com	
ltr	ecn no	dr	date	linear	.X ± .5	projection	title		code		
D					.XX ± .20		34P BTB DOCKING CONNECTOR		-		
					.XXX ± .100		PLUG PCB LAYOUT				
				angles	0° ± 2'	mm	product family BOARD TO BOARD		-		
		dr	Richard Chiu	8/01/03'		scale	size		sheet		
		engr	Richard Chiu	8/01/03'		10:1	dwg no		2 of 3		
		chr	Paul Wang	8/01/03'			10016521				
		appd	JENN TSAO	8/01/03'							
sheet index	revision sheet										

All rights strictly reserved. Reproduction or issue to third parties in any form  
 whatever is not permitted without written authority from the proprietor.  
 Property © c FCI ELECTRONICS Copyright FCI ELECTRONICS INC.

Tous droits strictement réservés. Reproduction ou communication a des tiers interdite  
 sous quelque forme que ce soit sans autorisation écrite du propriétaire.  
 Propriété © c FCI ELECTRONICS. Droits de reproduction FCI ELECTRONICS INC.

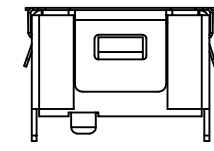
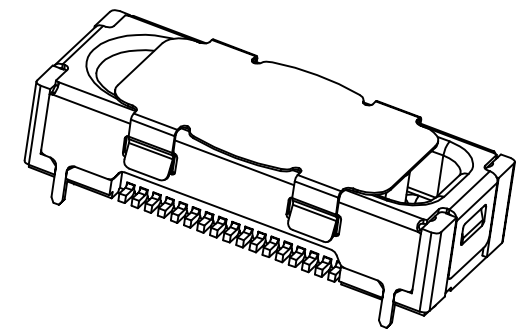
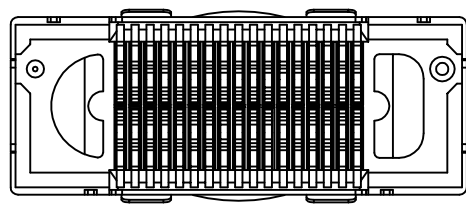
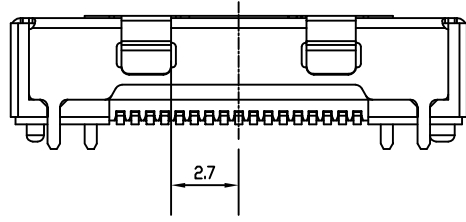
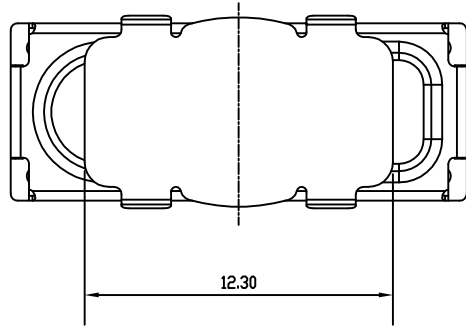

mat'l. code		tolerances unless otherwise specified		CUSTOMER COPY		FCI www.fciconnect.com	
ltr	ecn no	dr	date	linear	.X ± .5	projection	title
D					.XX ± .20		34P BTB DOCKING CONNECTOR
					.XXX ± .100		PLUG PCB LAYOUT
				angles	0° ± 2°	product family	BOARD TO BOARD
		dr	Richard Chiu	8/01/03'		size	dwg no
		engr	Richard Chiu	8/01/03'	mm		
		chr	Paul Wang	8/01/03'	scale		
		appd	JENN TSAD	8/01/03'	10:1	A3	10016521
sheet	revision						code
index	sheet						3 of 3