

THIS DRAWING IS UNPUBLISHED. RELEASED FOR PUBLICATION
 © COPYRIGHT - BY - TE CONNECTIVITY ALL RIGHTS RESERVED.

REVISIONS				
P	LTR	DESCRIPTION	DATE	APVD
	A2	REVISED PER ECO-19-012700	15AUG2019	RS LB

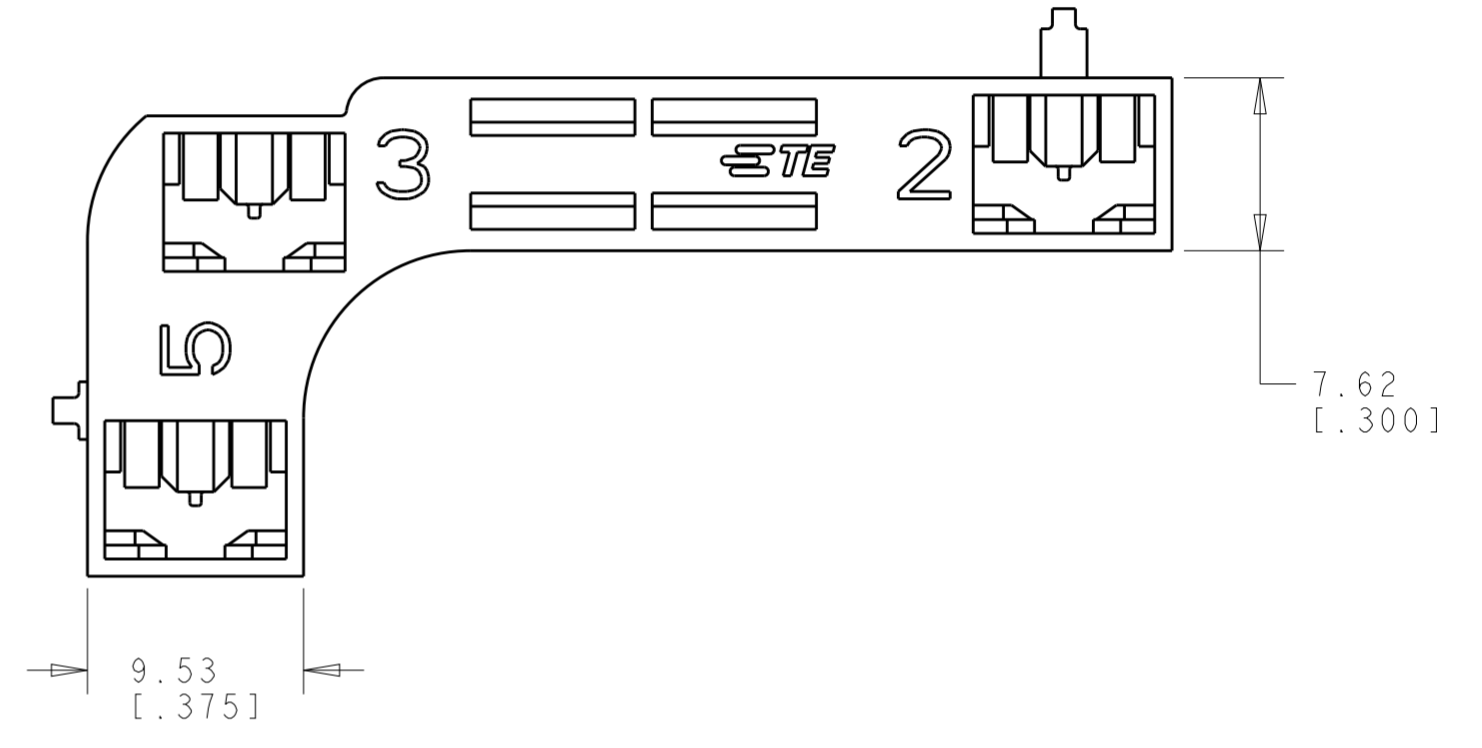

- USE WITH 250 SERIES MARK II POSITIVE LOCK TERMINALS 2238155, 2238156 OR 170329
 - NOTE DELETED
- △ 3 SWITCH RECOMMENDED TAB LAYOUT TO BE WITHIN ±0.127 [.005] OF TE HOUSING CENTERLINES AND CONFORM TO .250 X .032 UL 310 DIMENSIONS

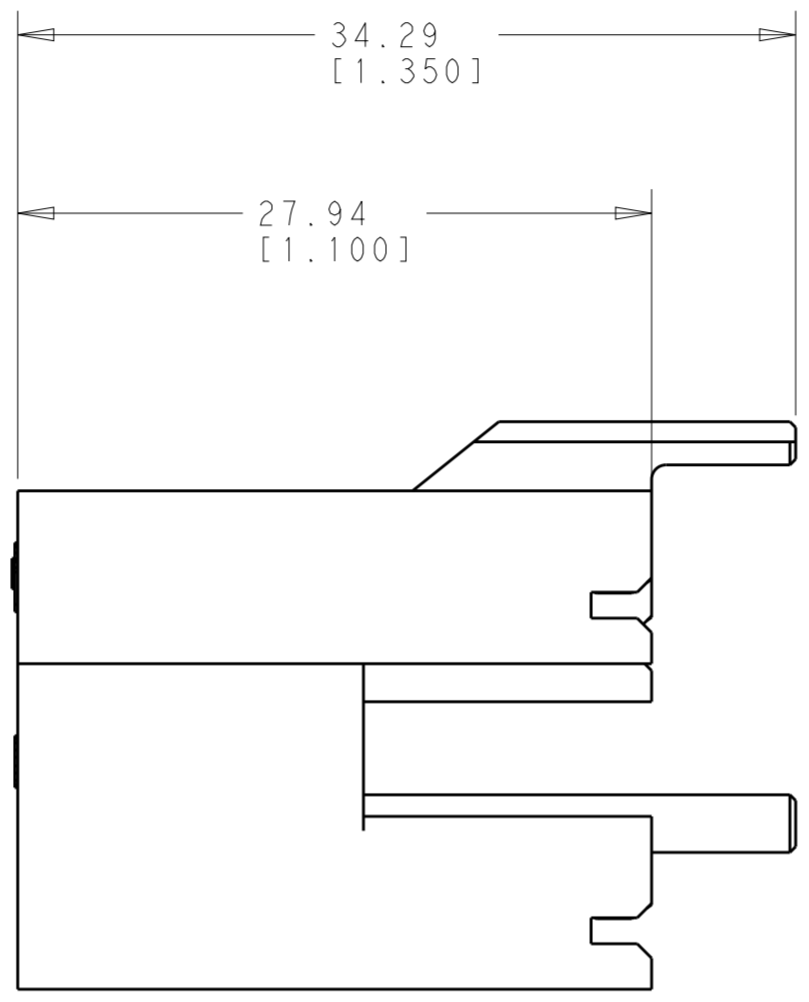
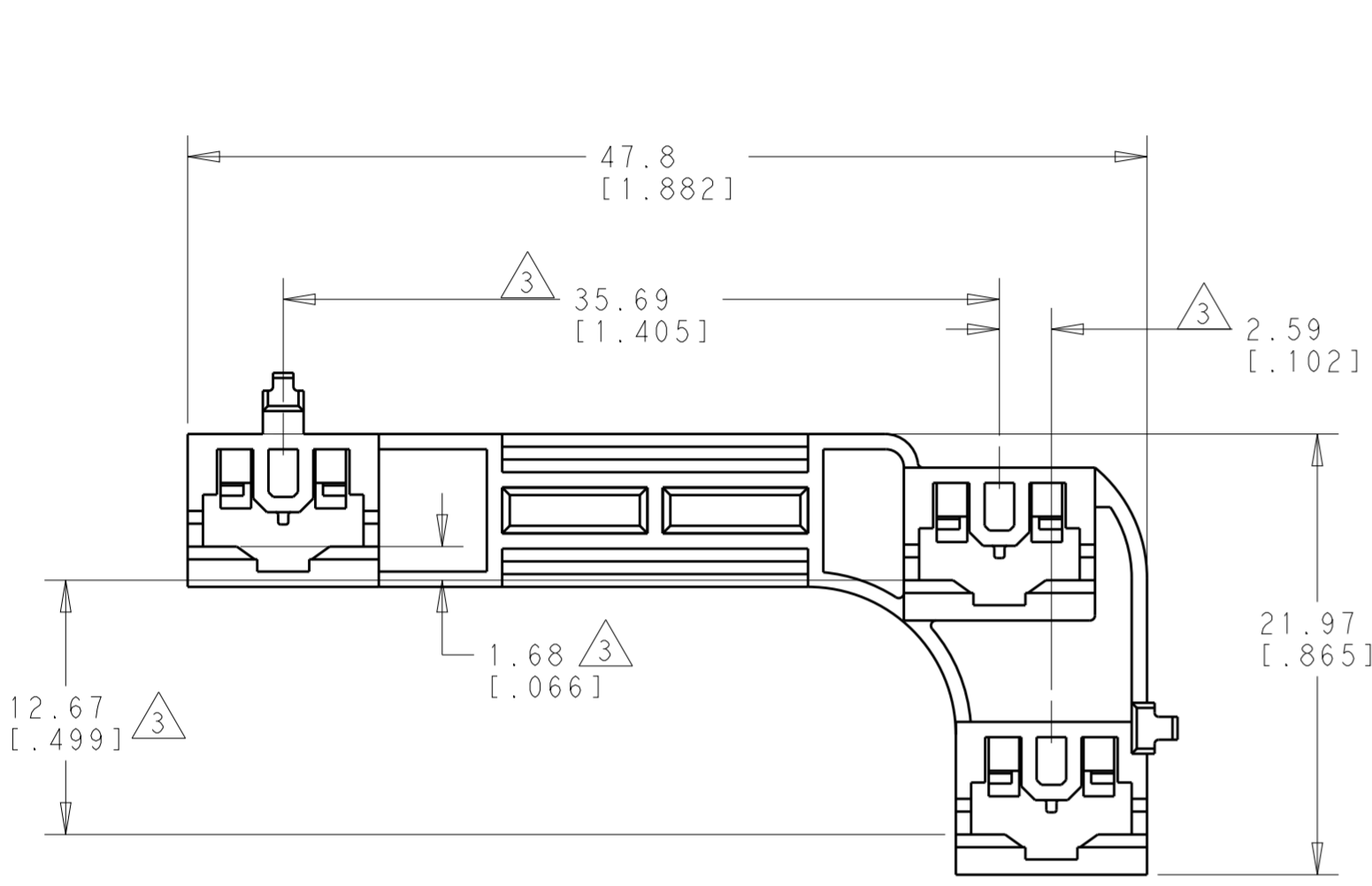
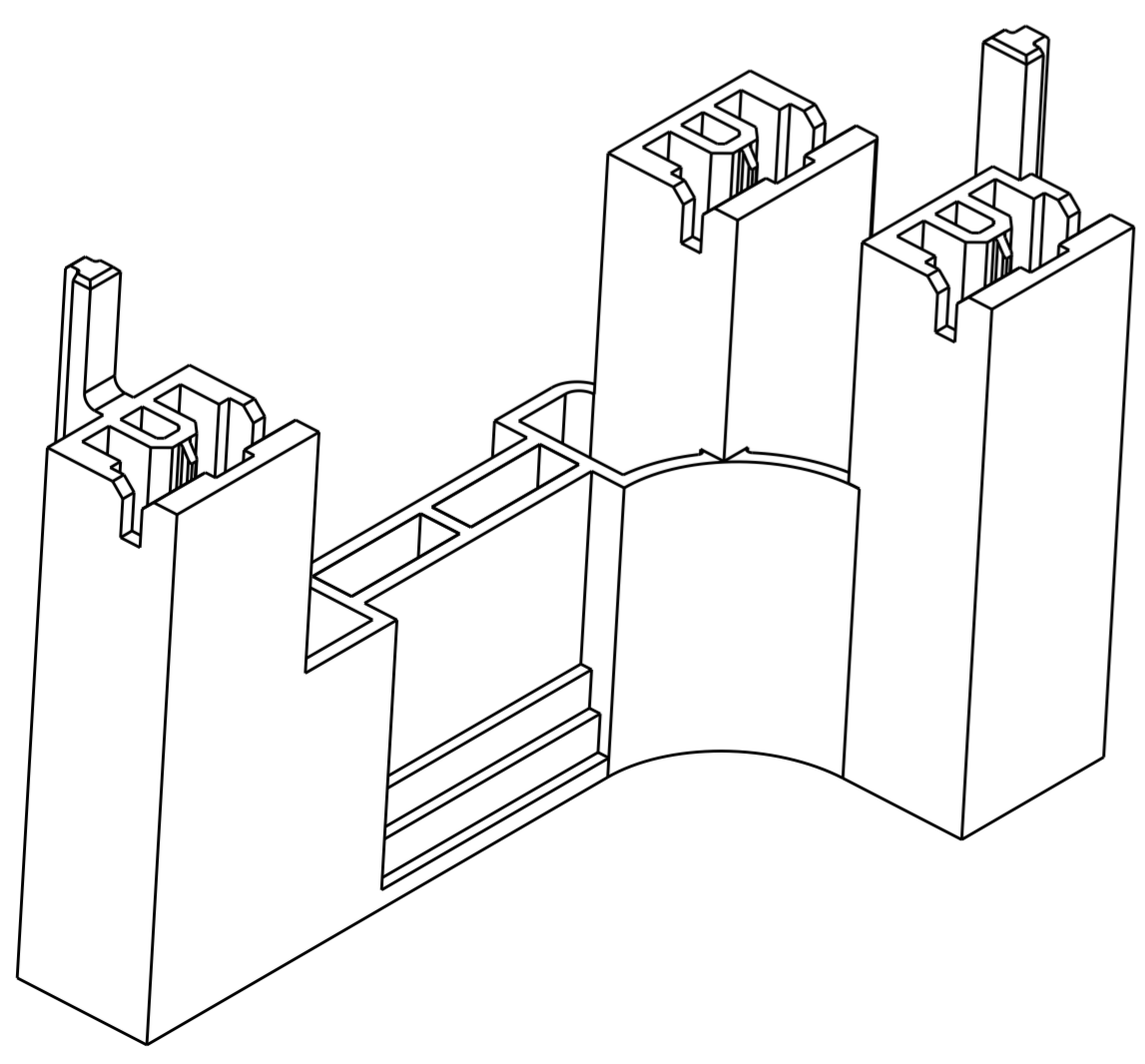

THIS DRAWING IS A CONTROLLED DOCUMENT.		DWN 17FEB2017 BASVESH WARAD	V0, 130C	BLACK	1969865-1
DIMENSIONS: mm [INCHES]		CHK 17FEB2017 DIDONATO, MICHAEL	RATINGS	COLOR	PART NUMBER
TOLERANCES UNLESS OTHERWISE SPECIFIED:		APVD 17FEB2017 DIDONATO, MICHAEL	TE Connectivity		
0 PLC ± 1 PLC ± 2 PLC ±0.38 [.015] 3 PLC ± 4 PLC ± ANGLES ±5° FINISH -		PRODUCT SPEC - APPLICATION SPEC - WEIGHT -			
MATERIAL NYLON		CUSTOMER DRAWING			