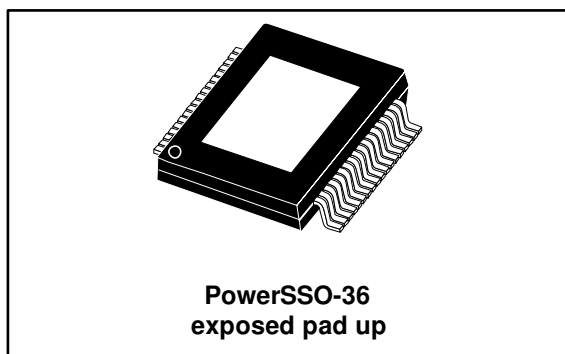

100 W mono BTL class-D audio amplifier

Datasheet - production data

Features

- 100 W output power at THD = 10% with $R_L = 6 \Omega$ and $V_{CC} = 36 \text{ V}$
- 80 W output power at THD = 10% with $R_L = 8 \Omega$ and $V_{CC} = 34 \text{ V}$
- Wide-range single-supply operation (14 - 39 V)
- High efficiency ($\eta = 90\%$)
- Four selectable, fixed gain settings of nominally 25.6 dB, 31.6 dB, 35.1 dB and 37.6 dB

- Differential inputs minimize common-mode noise
- Standby and mute features
- Short-circuit protection
- Thermal overload protection
- Externally synchronizable

Description

The TDA7498MV is a mono BTL class-D audio amplifier with single power supply designed for home systems and active speaker applications.

It comes in a 36-pin PowerSSO package with exposed pad up (EPU) to facilitate mounting a separate heatsink.

Table 1: Device summary

Order code	Operating temp. range	Package	Packaging
TDA7498MVTR	-40 to 85 °C	PowerSSO36 (EPU)	Tape and reel

Contents

1	Device block diagram.....	5
2	Pin description	6
2.1	Pinout.....	6
2.2	Pin list	7
3	Electrical specifications.....	8
3.1	Absolute maximum ratings.....	8
3.2	Thermal data.....	8
3.3	Recommended operating conditions.....	8
3.4	Electrical specifications	9
4	Characterization curves.....	11
4.1	Test board.....	11
4.2	Characterization curves	12
4.2.1	For $R_L = 6 \Omega$	12
4.2.2	For $R_L = 8 \Omega$	14
5	Application information	16
5.1	Application circuit.....	16
5.2	Mode selection.....	17
5.3	Gain setting.....	18
5.4	Input resistance and capacitance.....	18
5.5	Internal and external clocks	19
5.5.1	Master mode (internal clock).....	19
5.5.2	Slave mode (external clock).....	19
5.6	Output low-pass filter	20
5.7	Protection functions.....	20
5.8	Diagnostic output	21
6	Package information	22
6.1	PowerSSO-36 EPU package information.....	22
7	Revision history	25

List of tables

Table 1: Device summary	1
Table 2: Pin description list	7
Table 3: Absolute maximum ratings	8
Table 4: Thermal data	8
Table 5: Recommended operating conditions	8
Table 6: Electrical specifications	9
Table 7: Mode settings	17
Table 8: Gain settings	18
Table 9: How to set up SYNCLK	19
Table 10: PowerSSO-36 EPU package mechanical data	24
Table 11: Document revision history	25

List of figures

Figure 1: Internal block diagram	5
Figure 2: Pin connections (top view, PCB view)	6
Figure 3: Test board.....	11
Figure 4: Output power (THD = 10%) vs. supply voltage	12
Figure 5: THD vs. output power	12
Figure 6: THD vs. frequency (1 W)	12
Figure 7: THD vs. frequency (100 mW)	12
Figure 8: Frequency response	13
Figure 9: FFT performance (0 dBFS)	13
Figure 10: FFT performance (-60 dBFS)	13
Figure 11: Output power (THD = 10%) vs. supply voltage	14
Figure 12: THD vs. output power	14
Figure 13: THD vs. frequency (1 W)	14
Figure 14: THD vs. frequency (100 mW)	14
Figure 15: Frequency response	15
Figure 16: FFT performance (0 dB)	15
Figure 17: FFT performance (-60 dB)	15
Figure 18: Application circuit.....	16
Figure 19: Standby and mute circuits	17
Figure 20: Turn on/off sequence for minimizing speaker "pop"	17
Figure 21: Input circuit and frequency response	18
Figure 22: Master and slave connection.....	19
Figure 23: Typical LC filter for an 8 Ω speaker	20
Figure 24: Typical LC filter for a 6 Ω speaker	20
Figure 25: Behavior of pin DIAG for various protection conditions.....	21
Figure 26: PowerSSO-36 EPU package outline	23

1 Device block diagram

Figure 1: "Internal block diagram" shows the block diagram of the TDA7498MV.

Figure 1: Internal block diagram

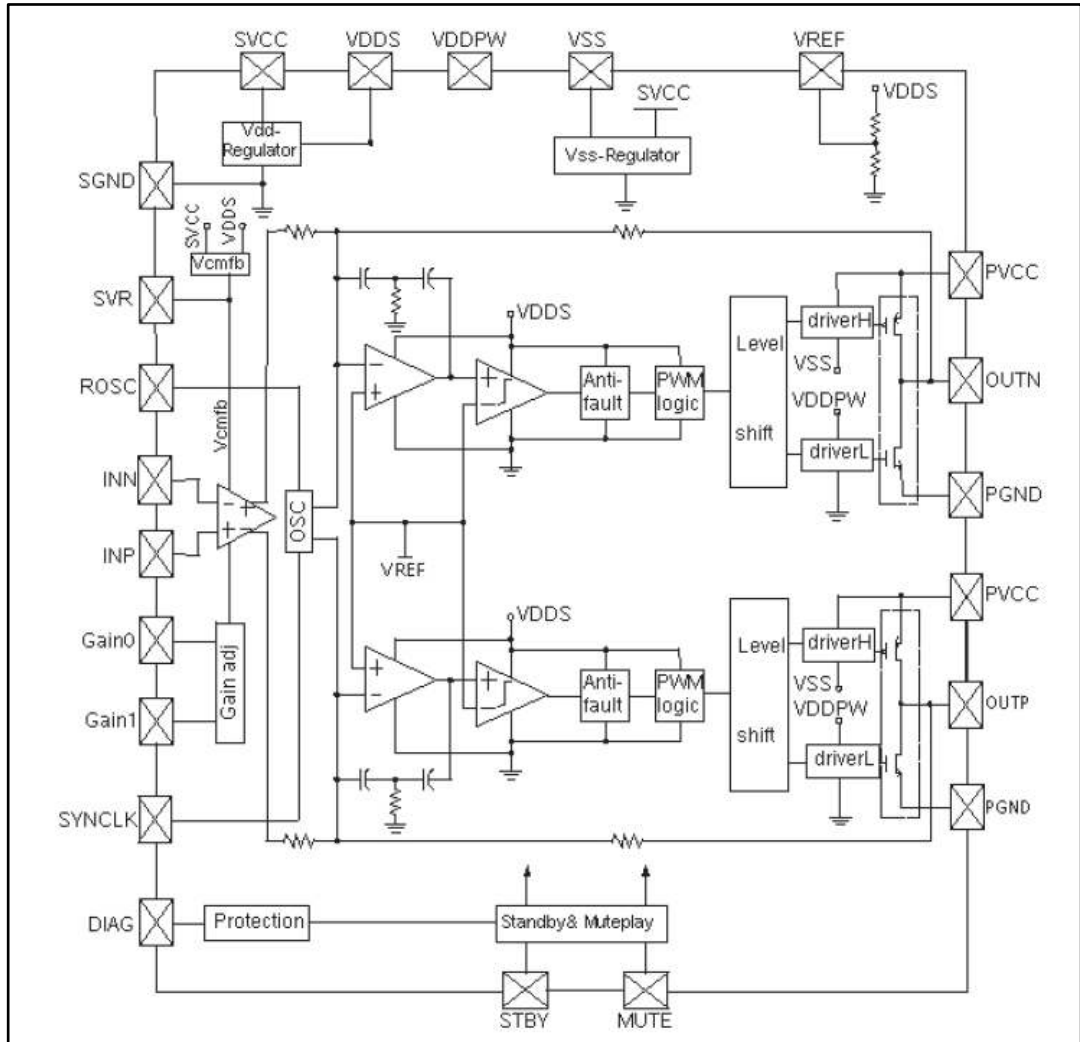

2 Pin description

2.1 Pinout

Figure 2: Pin connections (top view, PCB view)

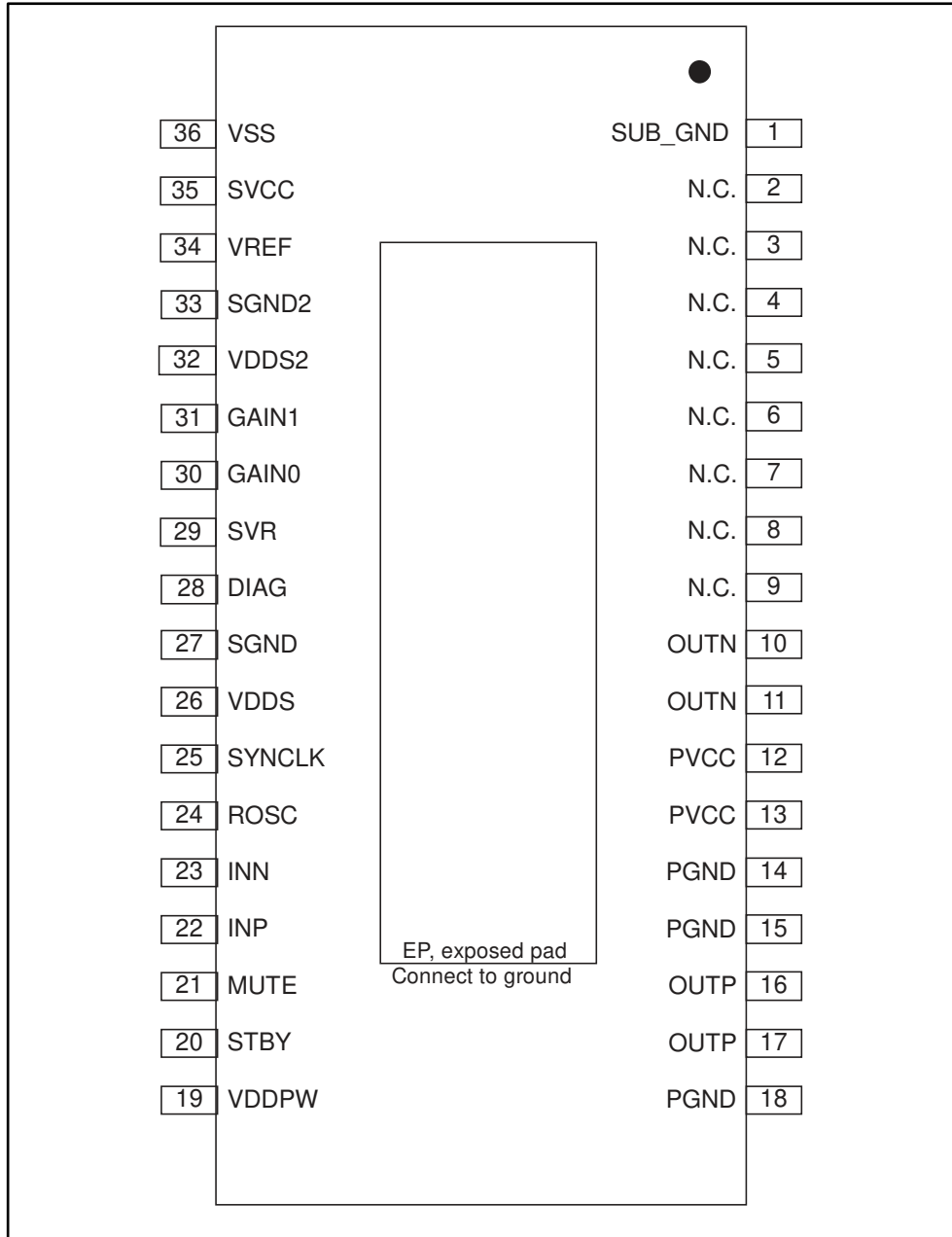

2.2 Pin list

Table 2: Pin description list

Number	Name	Type	Description
1	SUB_GND	PWR	Connect to the frame
2, 3	NC	-	No internal connection
4, 5	NC	-	No internal connection
6, 7	NC	-	No internal connection
8, 9	NC	-	No internal connection
10, 11	OUTN	O	Negative PWM output for audio channel
12, 13	PVCC	PWR	Power supply for audio channel
14, 15	PGND	PWR	Power stage ground
16, 17	OUTP	O	Positive PWM output for audio channel
18	PGND	PWR	Power stage ground
19	VDDPW	O	3.3-V (nominal) regulator output referred to ground for power stage
20	STBY	I	Standby mode control
21	MUTE	I	Mute mode control
22	INP	I	Positive differential input
23	INN	I	Negative differential input
24	ROSC	O	Master oscillator frequency-setting pin
25	SYNCLK	I/O	Clock in/out for external oscillator
26	VDDS	O	3.3-V (nominal) regulator output referred to ground for signal blocks
27	SGND	PWR	Signal ground
28	DIAG	O	Open-drain diagnostic output
29	SVR	O	Supply voltage rejection
30	GAIN0	I	Gain setting input 1
31	GAIN1	I	Gain setting input 2
32	VDDS2	O	Connect to VDDS (pin 26)
33	SGND2	PWR	Connect to SGND (pin 27)
34	VREF	O	Half VDDS (nominal) referred to ground
35	SVCC	PWR	Signal power supply decoupling
36	VSS	O	3.3-V (nominal) regulator output referred to power supply
-	EP	-	Exposed pad for heatsink, to be connected to ground

3 Electrical specifications

3.1 Absolute maximum ratings

Table 3: Absolute maximum ratings

Symbol	Parameter	Value	Unit
V_{CC_MAX}	DC supply voltage for pins PVCCA, PVCCB, SVCC	45	V
V_{L_MAX}	Voltage limits for input pins STBY, MUTE, INNA, INPA, INNB, INPB, GAIN0, GAIN1	-0.3 to 3.6	V
T_{j_MAX}	Operating junction temperature	0 to 150	°C
T_{op_MAX}	Operating temperature	-40 to 85	°C
T_{stg}	Storage temperature	-40 to 150	°C



Warning: Stresses beyond those listed under “Absolute maximum ratings” may cause permanent damage to the device. These are stress ratings only, and functional operation of the device at these or any other conditions beyond those indicated under “Recommended operating condition” are not implied. Exposure to absolute maximum rated conditions for extended periods may affect device reliability. In the real application, the power supply with nominal value rated inside recommended operating conditions may rise beyond the maximum operating condition for a short time when no or very low current is sunk (amplifier in mute state). In this case the reliability of the device is guaranteed, provided that the absolute maximum rating is not exceeded.

3.2 Thermal data

Table 4: Thermal data

Symbol	Parameter	Min	Typ	Max	Unit
$R_{th\ j-case}$	Thermal resistance, junction to case	-	2	3	°C/W

3.3 Recommended operating conditions

Table 5: Recommended operating conditions

Symbol	Parameter	Min	Typ	Max	Unit
V_{CC}	Supply voltage for pins PVCCA, PVCCB	14	-	39	V
T_{amb}	Ambient operating temperature	-20	-	85	°C

3.4 Electrical specifications

Unless otherwise stated, the values in the table below are specified for the conditions:
 $V_{CC} = 36\text{ V}$, $R_L = 6\ \Omega$, $R_{OSC} = R_3 = 39\text{ k}\Omega$, $C_8 = 100\text{ nF}$, $f = 1\text{ kHz}$, $G_V = 25.6\text{ dB}$ and
 $T_{amb} = 25\text{ }^\circ\text{C}$.

Table 6: Electrical specifications

Symbol	Parameter	Condition	Min	Typ	Max	Unit
I_q	Total quiescent current	No LC filter, no load	-	40	60	mA
I_{qSTBY}	Quiescent current in standby	-	-	1	10	μA
V_{OS}	Output offset voltage	Play mode	-100	-	100	mV
		Mute mode	-60	-	60	
I_{OCP}	Overcurrent protection threshold	$R_L = 0\ \Omega$	5.5	7	-	A
T_{JS}	Junction temperature at thermal shutdown	-	-	150	-	$^\circ\text{C}$
R_i	Input resistance	Differential input	48	60	-	k Ω
V_{OVP}	Overvoltage protection threshold	-	42	43	-	V
V_{UVP}	Undervoltage protection threshold	-	-	-	8	V
R_{dsON}	Power transistor on-resistance	High side	-	0.2	-	Ω
		Low side	-	0.2	-	
P_o	Output power	THD = 10%	-	100	-	W
		THD = 1%	-	78	-	
P_o	Output power	$R_L = 8\ \Omega$, THD = 10%, $V_{CC} = 36\text{ V}$	-	80	-	W
P_D	Dissipated power	$P_o = 100\text{ W}$, THD = 10%	-	10	-	W
η	Efficiency	$P_o = 100\text{ W}$	-	90	-	%
THD	Total harmonic distortion	$P_o = 1\text{ W}$	-	0.1	-	%
G_V	Closed-loop gain	GAIN0 = L, GAIN1 = L	24.6	25.6	26.6	dB
		GAIN0 = L, GAIN1 = H	30.6	31.6	32.6	
		GAIN0 = H, GAIN1 = L	34.1	35.1	36.1	
		GAIN0 = H, GAIN1 = H	36.6	37.6	38.6	
ΔG_V	Gain matching	-	-1	-	1	dB
e_N	Total input noise	A Curve, $G_V = 20\text{ dB}$	-	15	-	μV
		$f = 22\text{ Hz to } 22\text{ kHz}$	-	25	50	
SVRR	Supply voltage rejection ratio	$f_r = 100\text{ Hz}$, $V_r = 0.5\text{ V}_{pp}$, $C_{SVR} = 10\ \mu\text{F}$	-	70	-	dB
T_r, T_f	Rise and fall times	-	-	50	-	ns
f_{SW}	Switching frequency	Internal oscillator	290	310	330	kHz
f_{SWR}	Output switching frequency range	With internal oscillator ⁽¹⁾	250	-	400	kHz
		With external oscillator ⁽²⁾	250	-	400	
V_{inH}	Digital input high (H)	-	2.3	-	-	V

Symbol	Parameter	Condition	Min	Typ	Max	Unit
V _{inL}	Digital input low (L)		-	-	0.8	
V _{STBY}	Pin STBY voltage high (H)	-	2.9	-	-	V
	Pin STBY voltage low (L)		-	-	0.5	
V _{MUTE}	Pin MUTE voltage high (H)	-	2.5	-	-	V
	Pin MUTE voltage low (L)		-	-	0.8	
A _{MUTE}	Mute attenuation	V _{MUTE} < 0.8 V	-	70	-	dB

Notes:

⁽¹⁾f_{SW} = 10⁶ / ((16 * R_{OSC} + 182) * 4) kHz, f_{SYNCLK} = 2 * f_{SW} with R3 = 39 kΩ (see [Figure 18: "Application circuit"](#)).

⁽²⁾f_{SW} = f_{SYNCLK} / 2 with the external oscillator.

4 Characterization curves

Figure 18: "Application circuit" shows the test circuit with which the characterization curves, shown in the next sections, were measured. Figure 3: "Test board" shows the PCB layout.

4.1 Test board

Figure 3: Test board

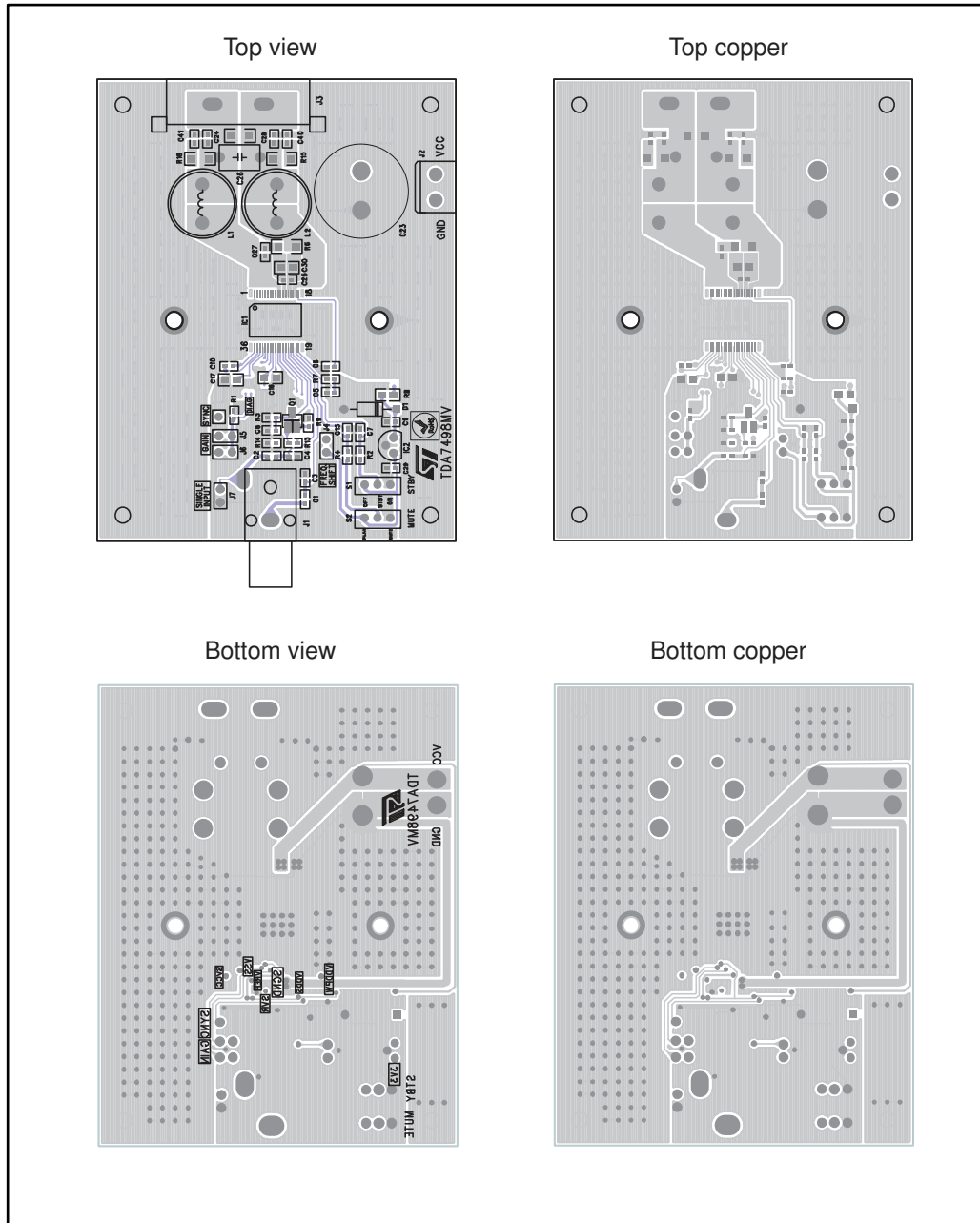

4.2 Characterization curves

Unless otherwise stated the measurements were made under the following conditions:

$V_{CC} = 36\text{ V}$, $f = 1\text{ kHz}$, $G_V = 25.6\text{ dB}$, $R_{OSC} = 39\text{ k}\Omega$, $C_{OSC} = 100\text{ nF}$, $T_{amb} = 25\text{ }^\circ\text{C}$

4.2.1 For $R_L = 6\ \Omega$

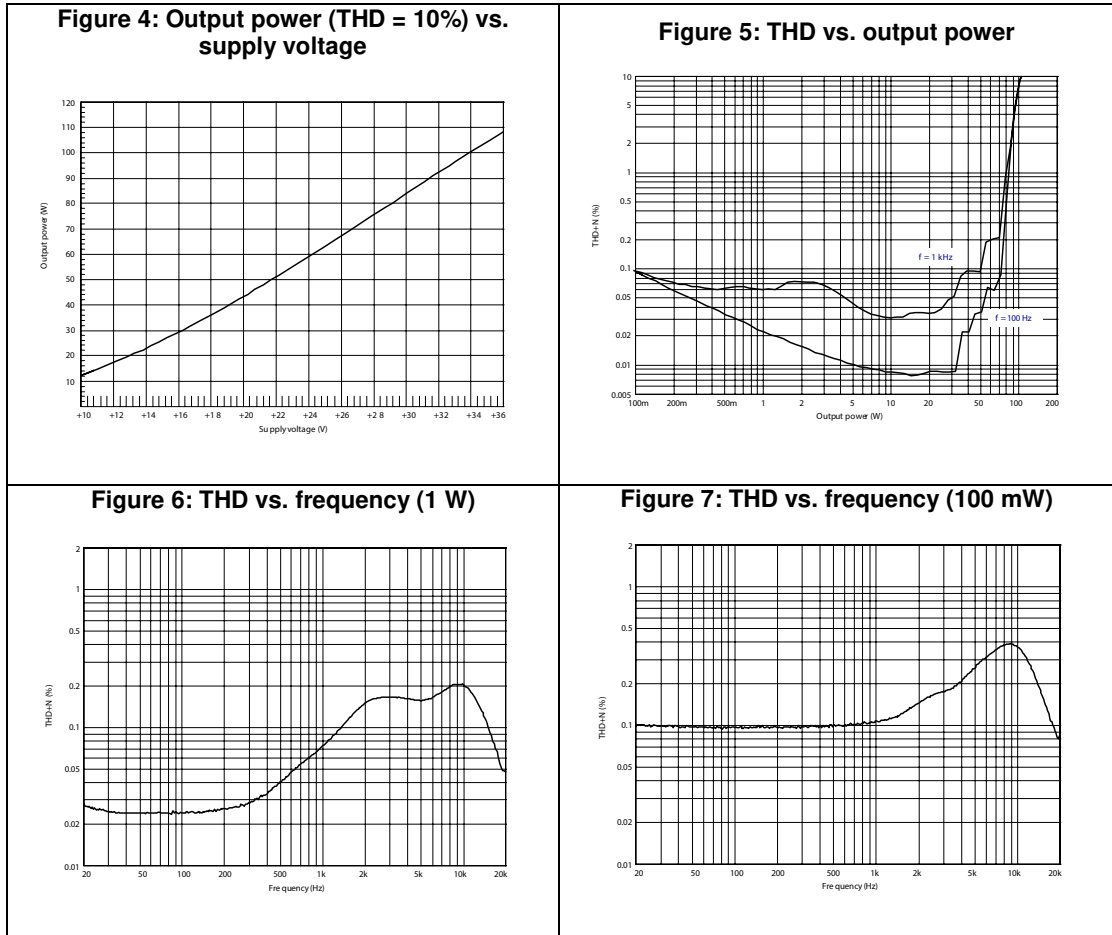

Figure 8: Frequency response

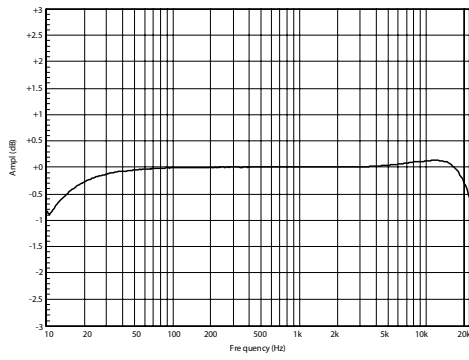

Figure 9: FFT performance (0 dBFS)

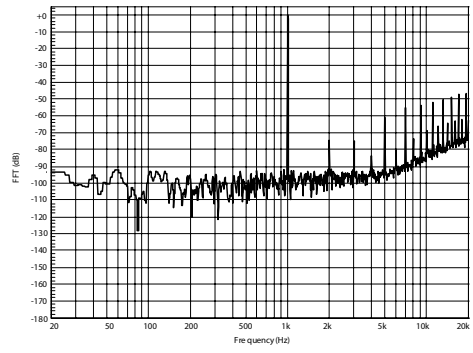
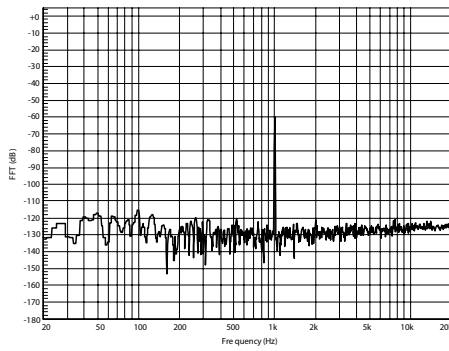

Figure 10: FFT performance (-60 dBFS)



4.2.2 For $R_L = 8 \Omega$

Figure 11: Output power (THD = 10%) vs. supply voltage

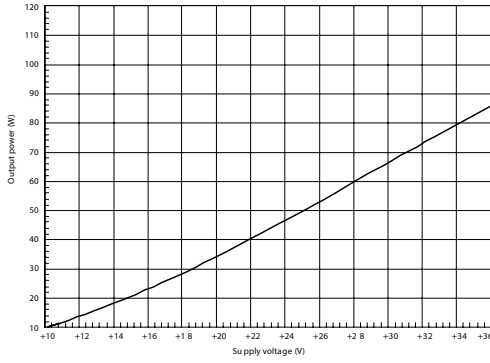

Figure 12: THD vs. output power

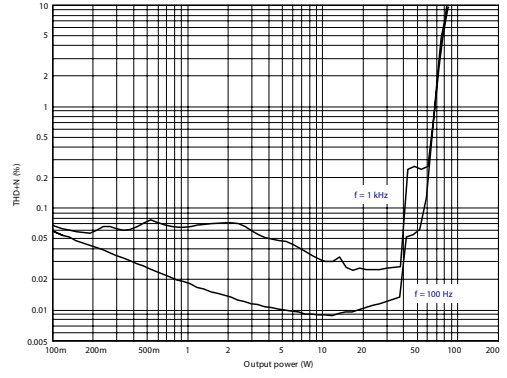

Figure 13: THD vs. frequency (1 W)

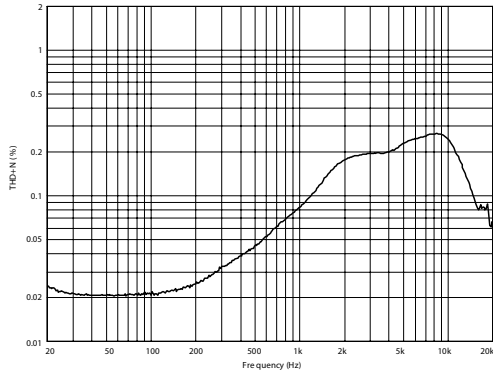

Figure 14: THD vs. frequency (100 mW)

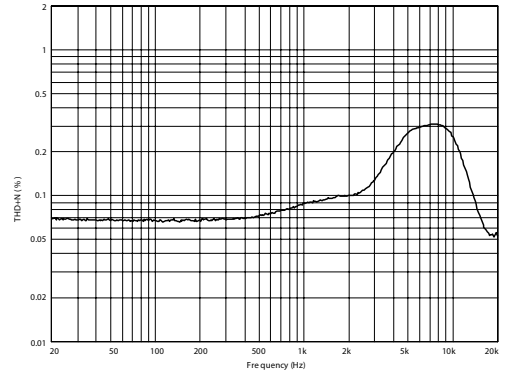

Figure 15: Frequency response

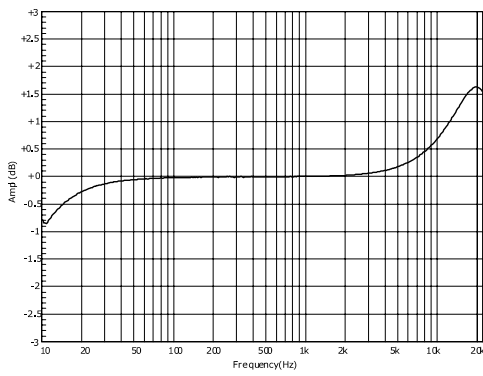

Figure 16: FFT performance (0 dB)

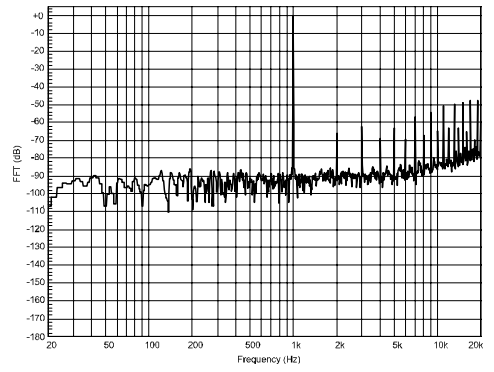
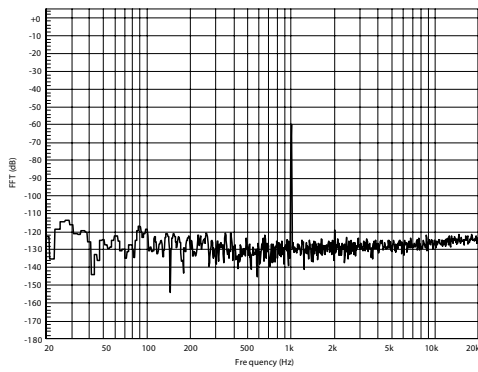

Figure 17: FFT performance (-60 dB)



5 Application information

5.1 Application circuit

Figure 18: Application circuit

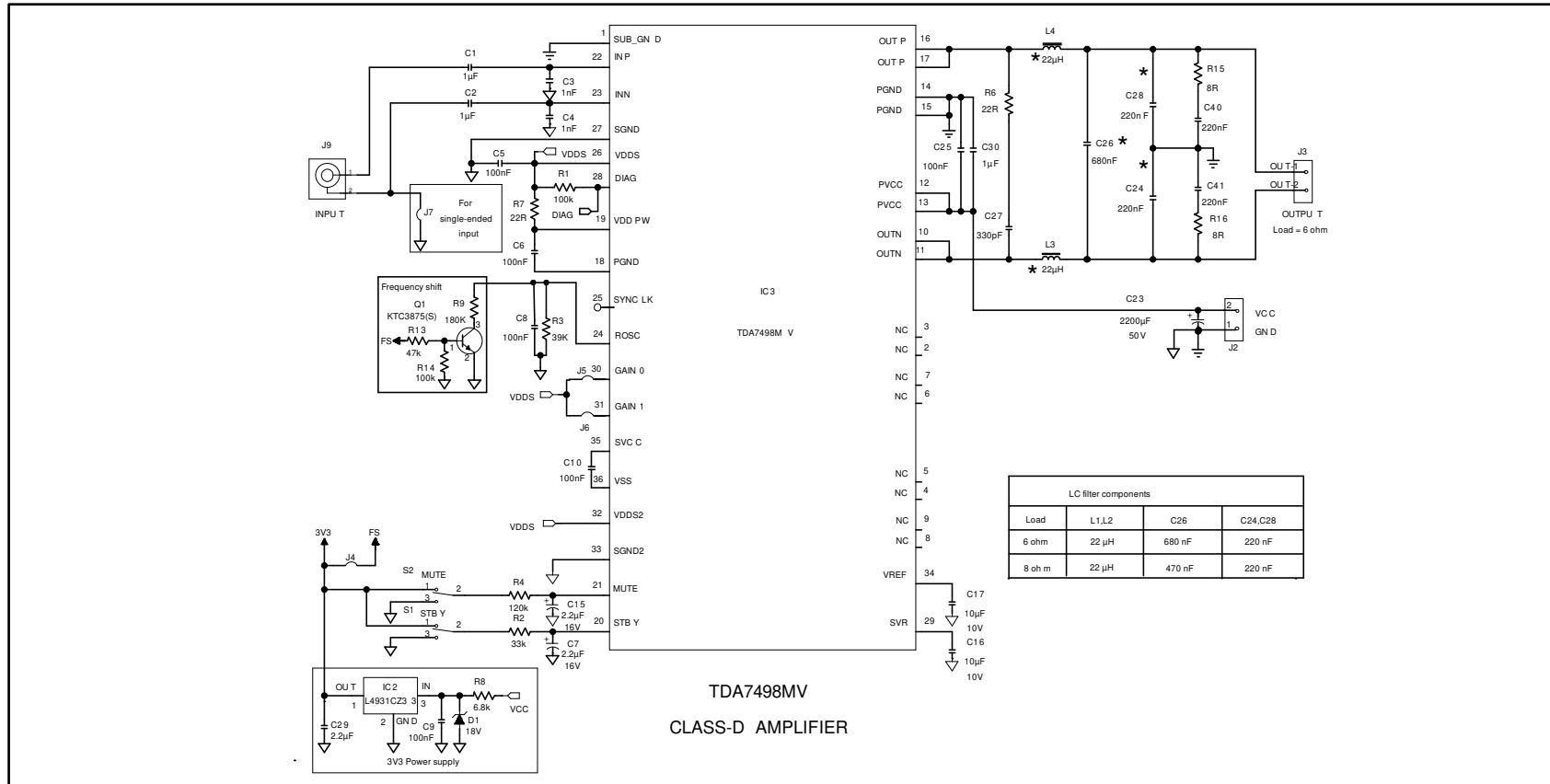

5.2 Mode selection

The three operating modes of the TDA7498MV are set by the two inputs, STBY (pin 20) and MUTE (pin 21).

- Standby mode: all circuits are turned off, very low current consumption.
- Mute mode: inputs are connected to ground and the positive and negative PWM outputs are at 50% duty cycle.
- Play mode: the amplifiers are active.

The protection functions of the TDA7498MV are enabled by pulling down the voltages of the STBY and MUTE inputs shown in *Figure 19: "Standby and mute circuits"*. The input current of the corresponding pins must be limited to 200 μ A.

Table 7: Mode settings

Mode	STBY	MUTE
Standby	L ⁽¹⁾	X (don't care)
Mute	H ⁽¹⁾	L
Play	H	H

Notes:

⁽¹⁾Drive levels defined in

Figure 19: Standby and mute circuits

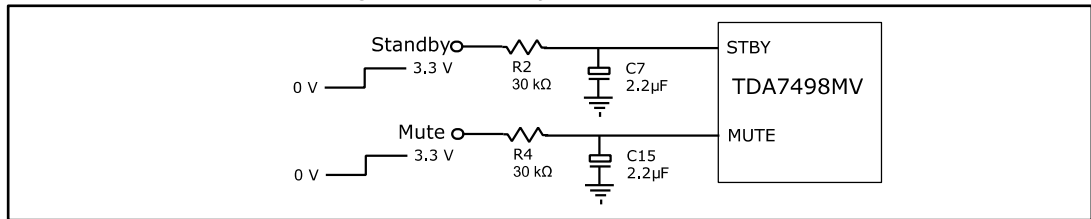
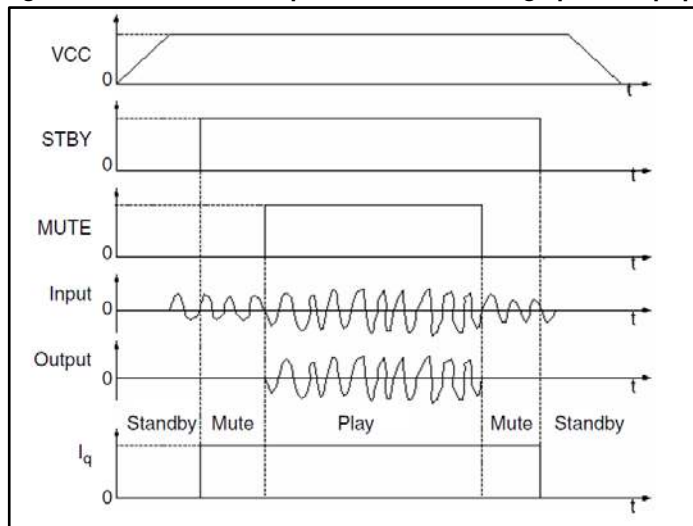

Figure 20: Turn on/off sequence for minimizing speaker "pop"



5.3 Gain setting

The gain of the TDA7498MV is set by the two inputs, GAIN0 (pin 30) and GAIN1 (pin31). Internally, the gain is set by changing the feedback resistors of the amplifier.

Table 8: Gain settings

GAIN0	GAIN1	Nominal gain, G _v (dB)
L	L	25.6
L	H	31.6
H	L	35.6
H	H	37.6

5.4 Input resistance and capacitance

The input impedance is set by an internal resistor R_i = 60 kΩ (typical). An input capacitor (C_i) is required to couple the AC input signal.

The equivalent circuit and frequency response of the input components are shown in [Figure 21: "Input circuit and frequency response"](#). For C_i = 470 nF the high-pass filter cutoff frequency is below 20 Hz:

$$f_c = 1 / (2 * \pi * R_i * C_i)$$

Figure 21: Input circuit and frequency response

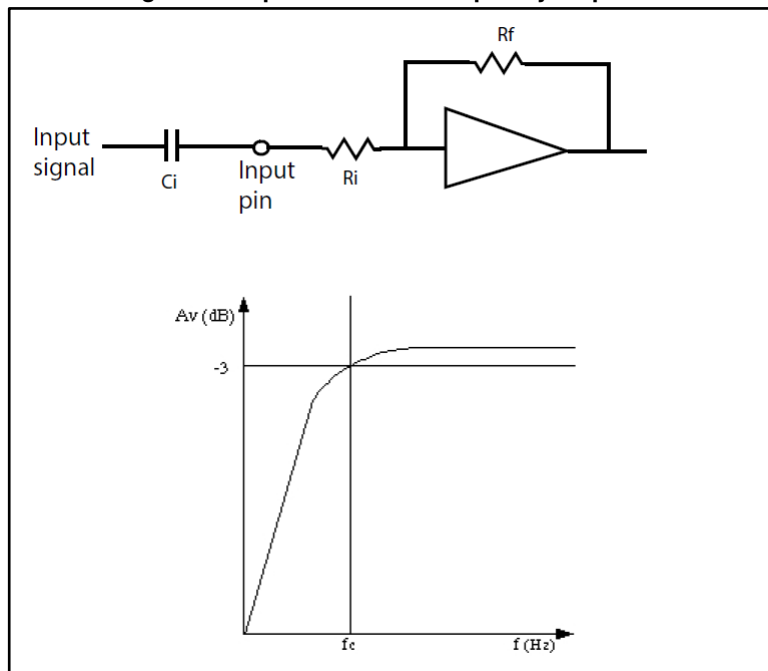

5.5 Internal and external clocks

The clock of the class-D amplifier can be generated internally or can be driven by an external source.

If two or more class-D amplifiers are used in the same system, it is recommended that all devices operate at the same clock frequency. This can be implemented by using one TDA7498MV as master clock, while the other devices are in slave mode, that is, externally clocked. The clock interconnect is via pin SYNCLK of each device. As explained below, SYNCLK is an output in master mode and an input in slave mode.

5.5.1 Master mode (internal clock)

Using the internal oscillator, the output switching frequency, f_{SW} , is controlled by the resistor, R_{OSC} , connected to pin ROOSC:

$$f_{SW} = 10^6 / [(R_{OSC} * 16 + 182) * 4] \text{ kHz}$$

where R_{OSC} is in kΩ.

In master mode, pin SYNCLK is used as a clock output pin whose frequency is:

$$f_{SYNCLK} = 2 * f_{SW}$$

For master mode to operate correctly then resistor R_{OSC} must be less than 60 kΩ as given below in [Table 9: "How to set up SYNCLK"](#).

5.5.2 Slave mode (external clock)

In order to accept an external clock input the pin ROOSC must be left open, that is, floating. This forces pin SYNCLK to be internally configured as an input as given in [Table 9: "How to set up SYNCLK"](#).

The output switching frequency of the slave devices is:

$$f_{SW} = f_{SYNCLK} / 2$$

Table 9: How to set up SYNCLK

Mode	ROOSC	SYNCLK
Master	$R_{OSC} < 60 \text{ k}\Omega$	Output
Slave	Floating (not connected)	Input

Figure 22: Master and slave connection

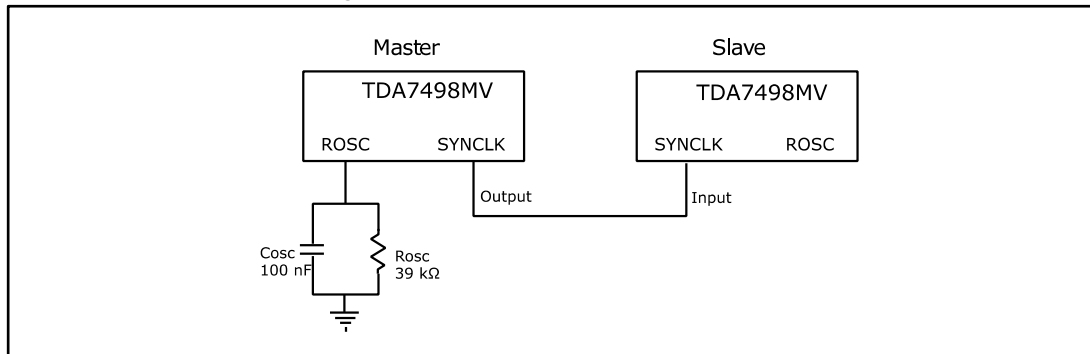

5.6 Output low-pass filter

To avoid EMI problems, it may be necessary to use a low-pass filter before the speaker. The cutoff frequency should be larger than 22 kHz and much lower than the output switching frequency. It is necessary to choose the L and C component values depending on the loudspeaker impedance. Some typical values, which give a cutoff frequency of 27 kHz, are shown in [Figure 23: "Typical LC filter for an 8 Ω speaker"](#) and [Figure 24: "Typical LC filter for a 6 Ω speaker"](#) below.

Figure 23: Typical LC filter for an 8 Ω speaker

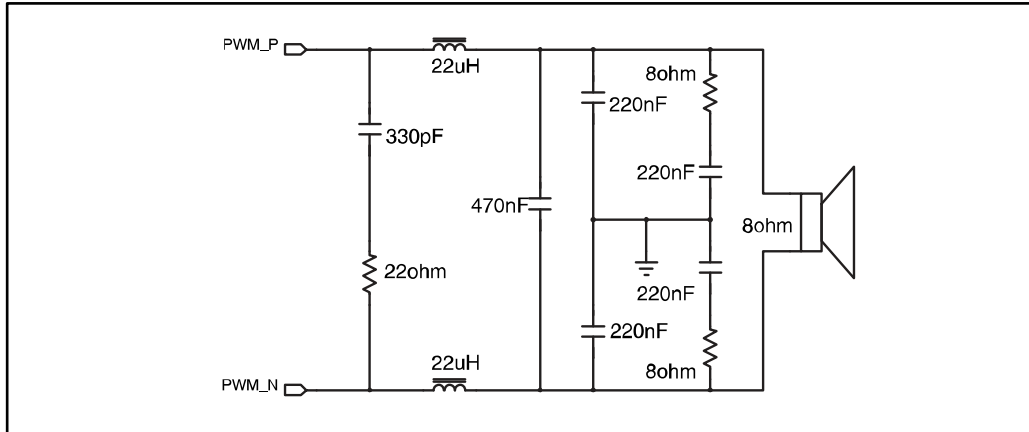
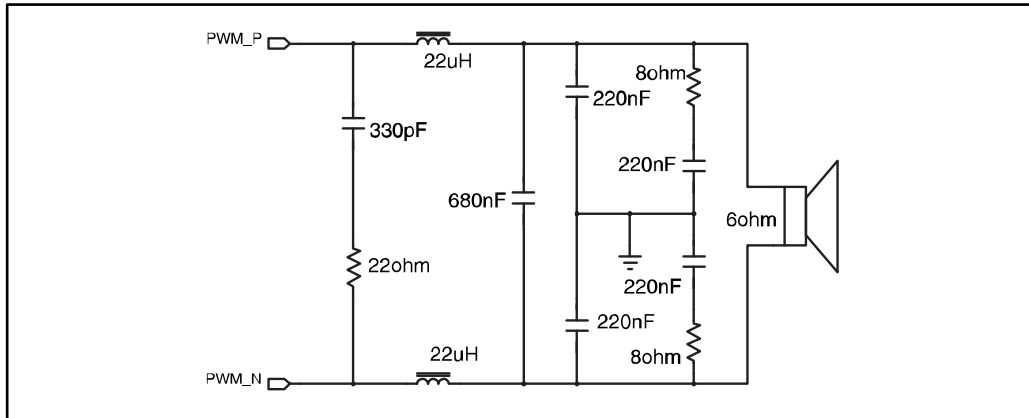

Figure 24: Typical LC filter for a 6 Ω speaker



5.7 Protection functions

The TDA7498MV is fully protected against overvoltages, undervoltages, overcurrents and thermal overloads as explained here.

Overvoltage protection (OVP)

If the supply voltage exceeds the value for V_{OVP} given in [Table 6: "Electrical specifications"](#), the overvoltage protection is activated which forces the outputs to the high impedance state. When the supply voltage falls back to within the operating range, the device restarts.

Undervoltage protection (UVP)

If the supply voltage drops below the value for V_{UVP} given in [Table 6: "Electrical specifications"](#), the undervoltage protection is activated which forces the outputs to the high impedance state. When the supply voltage recovers to within the operating range, the device restarts.

Overcurrent protection (OCP)

If the output current exceeds the value for I_{OCP} given in [Table 6: "Electrical specifications"](#), the overcurrent protection is activated which forces the outputs to the high impedance state. Periodically, the device attempts to restart. If the overcurrent condition is still present, then the OCP remains active. The restart time, T_{OC} , is determined by the RC components connected to pin STBY.

Thermal protection (OTP)

If the junction temperature, T_j , reaches 145 °C (nominally), the device goes to mute mode and the positive and negative PWM outputs are forced to 50% duty cycle. If the junction temperature reaches the value for T_j given in [Table 6: "Electrical specifications"](#), the device shuts down and the output is forced to the high-impedance state. When the device cools sufficiently, the device restarts.

5.8 Diagnostic output

The output pin DIAG is an open drain transistor. When any protection is activated, it switches to the high impedance state. The pin can be connected to a power supply (< 39 V) by a pull-up resistor whose value is limited by the maximum sinking current (200 μ A) of the pin.

Figure 25: Behavior of pin DIAG for various protection conditions

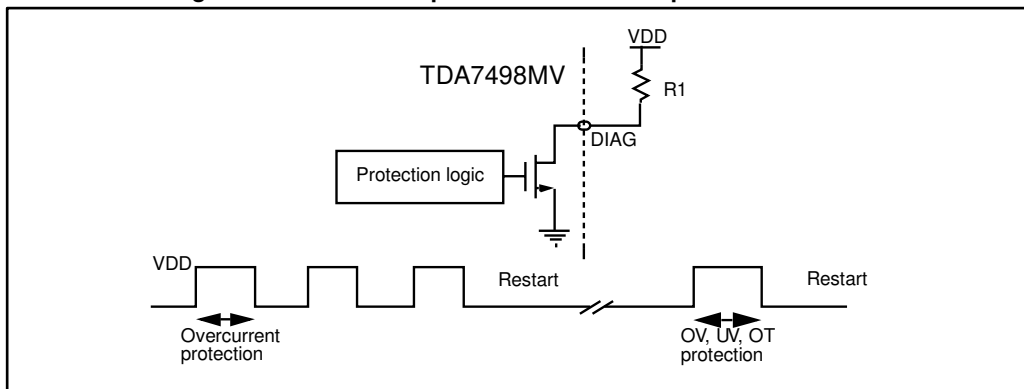

6 Package information

In order to meet environmental requirements, ST offers these devices in different grades of ECOPACK[®] packages, depending on their level of environmental compliance. ECOPACK[®] specifications, grade definitions and product status are available at: www.st.com. ECOPACK[®] is an ST trademark.

6.1 PowerSSO-36 EPU package information

The device comes in a 36-pin PowerSSO package with exposed pad up (EPU).

Figure 26: "PowerSSO-36 EPU package outline" shows the package outline and *Table 10: "PowerSSO-36 EPU package mechanical data"* gives the dimensions.

Figure 26: PowerSSO-36 EPU package outline

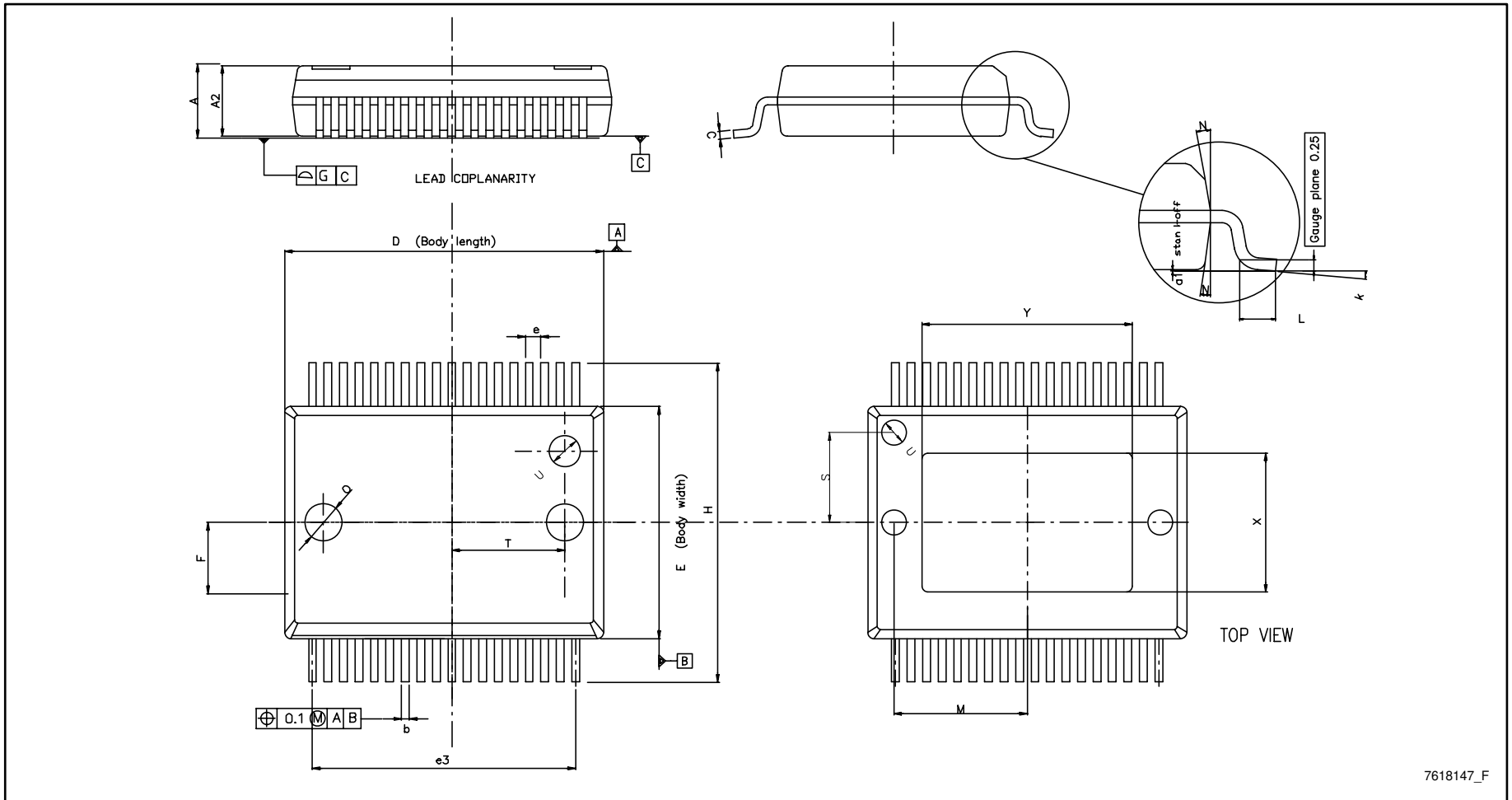

7618147_F

Table 10: PowerSSO-36 EPU package mechanical data

Symbol	Dimensions in mm			Dimensions in inches		
	Min.	Typ.	Max.	Min.	Typ.	Max.
A	2.15	-	2.45	0.085	-	0.096
A2	2.15	-	2.35	0.085	-	0.093
a1	0	-	0.10	0	-	0.004
b	0.18	-	0.36	0.007	-	0.014
c	0.23	-	0.32	0.009	-	0.013
D	10.10	-	10.50	0.398	-	0.413
E	7.40	-	7.60	0.291	-	0.299
e	-	0.5	-	-	0.020	-
e3	-	8.5	-	-	0.335	-
F	-	2.3	-	-	0.091	-
G	-	-	0.10	-	-	0.004
H	10.10	-	10.50	0.398	-	0.413
h	-	-	0.40	-	-	0.016
k	0	-	8 degrees	0	-	8 degrees
L	0.55	-	0.85	0.022	-	0.033
M	-	4.30	-	-	0.169	-
N	-	-	10 degrees	-	-	10 degrees
O	-	1.20	-	-	0.047	-
Q	-	0.80	-	-	0.031	-
S	-	2.90	-	-	0.114	-
T	-	3.65	-	-	0.144	-
U	-	1.00	-	-	0.039	-
X	4.10	-	4.70	0.161	-	0.185
Y	4.90	-	7.10	0.193	-	0.280

7 Revision history

Table 11: Document revision history

Date	Revision	Changes
30-Nov-2009	1	Initial release.
28-Jul-2010	2	Removed datasheet preliminary status, updated features list and updated Table 1: "Device summary" Added operating temperature range to Table 3: "Absolute maximum ratings" Updated minimum supply voltage and temperature range in Table 5: "Recommended operating conditions" Updated voltage for logical 1 on pin STBY in Table 6: "Electrical specifications "
27-Jan-2011	3	Updated application circuit in Figure 18: "Application circuit" .
24-Feb-2014	4	Updated order code in Table 1: "Device summary"
19-Sep-2014	5	Updated Figure 2: "Pin connections (top view, PCB view)" Updated package information (representation on page 1, Figure 26: "PowerSSO-36 EPU package outline" , Table 10: "PowerSSO-36 EPU package mechanical data").
09-Sep-2015	6	Updated V_{CC_MAX} in Table 3: "Absolute maximum ratings" Updated dimension L in Table 10: "PowerSSO-36 EPU package mechanical data" .

IMPORTANT NOTICE – PLEASE READ CAREFULLY

STMicroelectronics NV and its subsidiaries ("ST") reserve the right to make changes, corrections, enhancements, modifications, and improvements to ST products and/or to this document at any time without notice. Purchasers should obtain the latest relevant information on ST products before placing orders. ST products are sold pursuant to ST's terms and conditions of sale in place at the time of order acknowledgement.

Purchasers are solely responsible for the choice, selection, and use of ST products and ST assumes no liability for application assistance or the design of Purchasers' products.

No license, express or implied, to any intellectual property right is granted by ST herein.

Resale of ST products with provisions different from the information set forth herein shall void any warranty granted by ST for such product.

ST and the ST logo are trademarks of ST. All other product or service names are the property of their respective owners.

Information in this document supersedes and replaces information previously supplied in any prior versions of this document.

© 2015 STMicroelectronics – All rights reserved