

## Microprocessor Monitor

### Features:

- Precision Voltage Monitor:
  - Adjustable +4.5V or +4.75V
- Reset Pulse Width – 250 ms minimum
- No External Components
- Adjustable Watchdog Timer:
  - 150 ms, 600 ms or 1.2s
- Operating Voltage 4.0V to 5.5V
- Debounced Manual Reset Input for External Override

### General Description:

The TC1232 is a fully-integrated processor supervisor that provides three important functions to safeguard processor sanity: precision power on/off Reset control, Watchdog Timer and external Reset override.

On power-up, the TC1232 holds the processor in the Reset state for a minimum of 250 ms after  $V_{CC}$  is within tolerance to ensure a stable system start-up.

Microprocessor sanity is monitored by the on-board watchdog circuit. The microprocessor must provide a periodic low-going signal on the  $\overline{ST}$  input. Should the processor fail to supply this signal within the selected time-out period (150 ms, 600 ms or 1200 ms), an out-of-control processor is indicated and the TC1232 issues a processor Reset as a result.

The outputs of the TC1232 are immediately driven active when the PB input is brought low by an external push button switch or other electronic signal. When connected to a push button switch, the TC1232 provides contact debounce.

The TC1232 is packaged in a space-saving 8-Pin PDIP or SOIC package, a 16-Pin SOIC (wide) package and requires no external components.

### Block Diagram

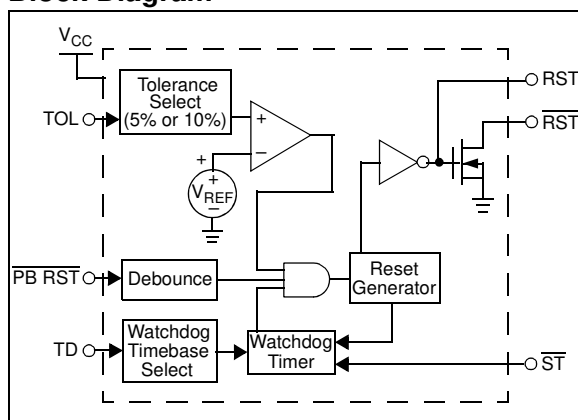

### Package Types

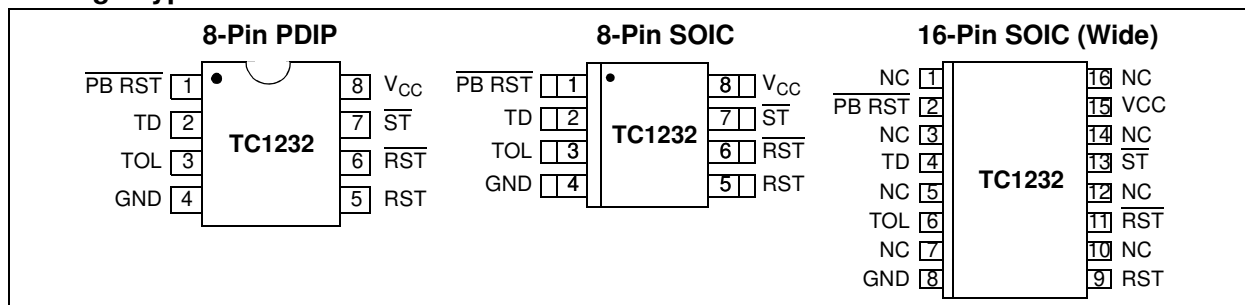

### Device Features

Device	$\overline{RST}$ pin			RST pin		Trip Points (Max)	Minimum Reset Active Time (ms)	WDI Input Typical Timeouts (ms)	MR Input
	Type	Pull-up Resistor	Active Level	Type	Active Level				
TC1232	Open-drain	External	Low	Push-pull	High	4.75V or 4.5V	250	150, 600 or 1200	Yes

# TC1232

## 1.0 ELECTRICAL CHARACTERISTICS

### Absolute Maximum Ratings†

Voltage on Any Pin (With Respect to GND)  
 ..... -0.3V to +5.8V

Operating Temperature Range:  
 C-Version ..... 0°C to +70°C  
 E-Version ..... -40°C to +85°C

Storage Temperature Range: ..... -65°C to +150°C

† Stresses above those listed under "Absolute Maximum Ratings" may cause permanent damage to the device. These are stress ratings only and functional operation of the device at these or any other conditions above those indicated in the operation sections of the specifications is not implied. Exposure to Absolute Maximum Rating conditions for extended periods may affect device reliability.

## DC CHARACTERISTICS

Electrical Specifications: Unless otherwise noted, $T_A = T_{MIN}$ to $T_{MAX}$ ; $V_{CC} = +4.0V$ to $5.5V$ .						
Parameters	Sym.	Min.	Typ.	Max.	Units	Conditions
Supply Voltage	$V_{CC}$	4.0	5.0	5.5	V	
$\overline{ST}$ and $\overline{PB RST}$ Input High Level	$V_{IH}$	2.0	—	$V_{CC} + 0.3$	V	Note 1
$\overline{ST}$ and $\overline{PB RST}$ Input Low Level	$V_{IL}$	-0.3	—	+0.8	V	
Input Leakage $\overline{ST}$ , TOL	$I_L$	-1.0	—	+1.0	$\mu A$	
Output Current RST	$I_{OH}$	-1.0	-12	—	mA	$V_{OH} = 2.4V$
Current RST, $\overline{RST}$	$I_{OL}$	2.0	10	—	mA	$V_{OL} = 0.4V$
Operating Current	$I_{CC}$	—	50	200	$\mu A$	Note 2
$V_{CC}$ 5% Trip Point	$V_{CCTP}$	4.50	4.62	4.74	V	TOL = GND (Note 3)
$V_{CC}$ 10% Trip Point	$V_{CCTP}$	4.25	4.37	4.49	V	TOL = $V_{CC}$ (Note 3)
Capacitance Electrical Characteristics: Unless otherwise noted, $T_A = +25^\circ C$ . (Note 4)						
Input Capacitance $\overline{ST}$ , TOL	$C_{IN}$	—	—	5	pF	
Output Capacitance RST, $\overline{RST}$	$C_{OUT}$	—	—	7	pF	

- Note 1:**  $\overline{PB RST}$  is internally pulled up to  $V_{CC}$  with an internal impedance of typically 40 k $\Omega$ .
- 2:** Measured with outputs open.
- 3:** All voltages referenced to GND.
- 4:** Ensured by design.

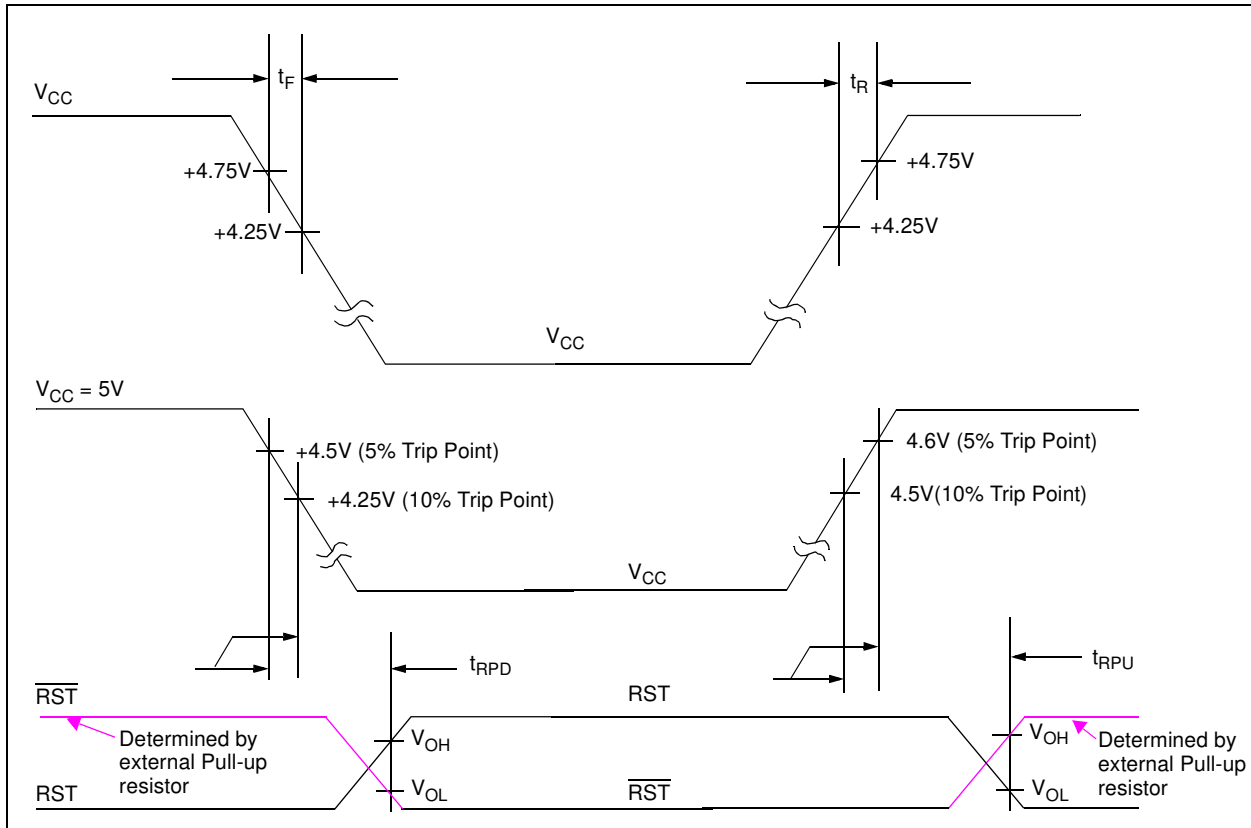

**FIGURE 1-1:** Rise Time, Fall Time and Reset Detected to Reset Active Timing Waveforms.

## AC CHARACTERISTICS

Electrical Specifications: Unless otherwise noted, $T_A = T_{MIN}$ to $T_{MAX}$ ; $V_{CC} = +4.0V$ to $5.5V$ .						
Parameters	Sym.	Min.	Typ.	Max.	Units	Conditions
$V_{CC}$ Fall Time	$t_F$	10	—	—	$\mu s$	Note 1
$V_{CC}$ Rise Time	$t_R$	0	—	—	$\mu s$	Note 1
$V_{CC}$ Trip Point Detected to RST High and $\overline{RST}$ Low	$t_{RPD}$	—	—	100	ns	$V_{CC}$ falling
$V_{CC}$ Trip Point Detected to RST High and $\overline{RST}$ Open	$t_{RPU}$	250	610	1000	ms	$V_{CC}$ rising (Note 2)

**Note 1:** Ensured by design.

**2:**  $t_R = 5 \mu s$ .

# TC1232

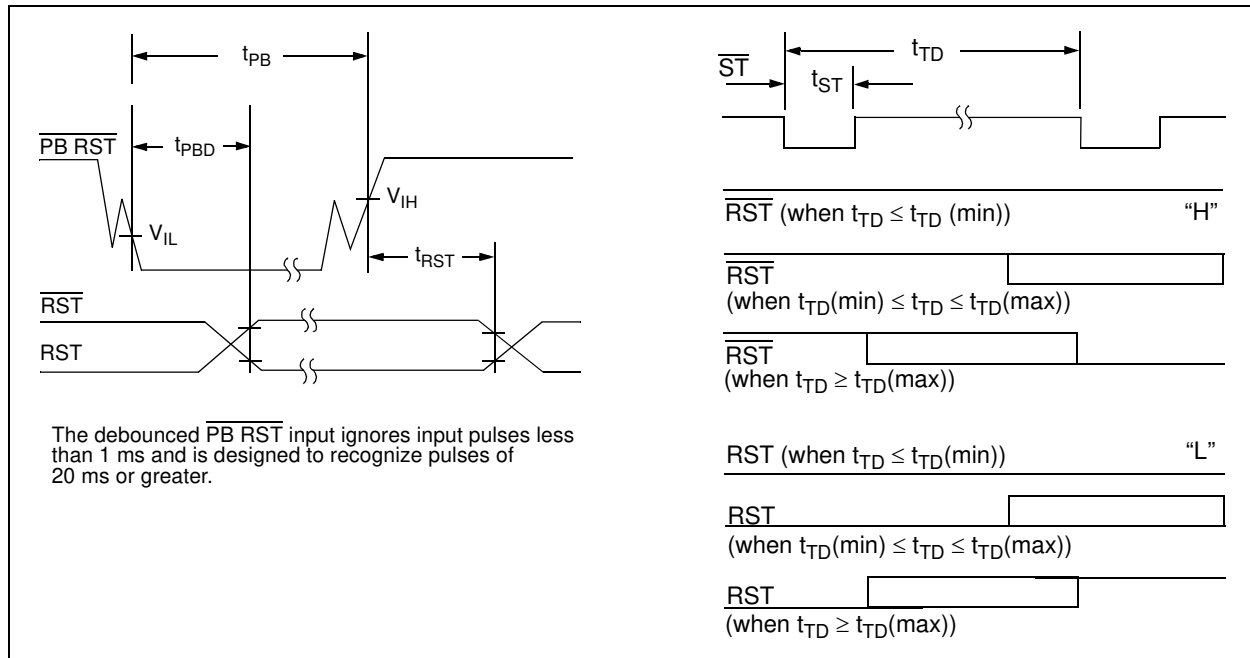

**FIGURE 1-2:** Push Button Reset and Watchdog Timer Reset Timing Waveforms.

## AC CHARACTERISTICS (CONTINUED)

**Electrical Specifications:** Unless otherwise noted,  $T_A = T_{\text{MIN}}$  to  $T_{\text{MAX}}$ ;  $V_{\text{CC}} = +4.0\text{V}$  to  $5.5\text{V}$ .

Parameters	Sym.	Min.	Typ.	Max.	Units	Conditions
PB $\overline{\text{RST}}$ Pulse Width	$t_{\text{PB}}$	20	—	—	ms	Note 1
PB $\overline{\text{RST}}$ Falling Edge Low to Reset Active	$t_{\text{PBD}}$	1	4	20	ms	
PB $\overline{\text{RST}}$ Rising Edge High to Reset Inactive	$t_{\text{RST}}$	250	610	1000	ms	
$\overline{\text{ST}}$ Pulse Width	$t_{\text{ST}}$	20	—	—	ns	
$\overline{\text{ST}}$ Time-out Period	$t_{\text{TD}}$	62.5	150	250	ms	TD Pin = 0V
		250	600	1000	ms	TD Pin = Open
		500	1200	2000	ms	TD Pin = $V_{\text{CC}}$

**Note 1:**  $\overline{\text{PB RST}}$  must be held low for a minimum of 20 ms to ensure a Reset.

## 2.0 TYPICAL PERFORMANCE CURVES

Performance Graphs are not available.

# TC1232

## 3.0 PIN DESCRIPTIONS

The descriptions of the pins are listed in [Table 3-1](#).

**TABLE 3-1: PIN FUNCTION TABLES**

Pin No.		Symbol	Pin Type	Buffer/Driver Type	Function
8-pin PDIP, SOIC	16-pin SOIC				
1	2	PB RST	I	ST	Push Button Reset Input. Input for a Manual Reset Switch. This input debounces (ignores) pulses less than 1 ms in duration and is ensured to recognize inputs of 20 ms or greater. L = Manual Reset Switch is Active, Force RST/RST pins Active H = Manual Reset Switch is Inactive. State of RST/RST pins determined by other system conditions.
2	4	TD	I	ST	Time Delay Input. The voltage level on this input determines the Watchdog Timer Time-out period. TD = 0V → t <sub>TD</sub> = 150 ms TD = Open → t <sub>TD</sub> = 600 ms TD = V <sub>CC</sub> → t <sub>TD</sub> = 1.2s
3	6	TOL	I	ST	Tolerance Input. TOL = GND, Max Voltage Trip Point (V <sub>CCTP</sub> ) = 4.75V (5% tolerance) TOL = V <sub>CC</sub> , Max Voltage Trip Point (V <sub>CCTP</sub> ) = 4.5V (10% tolerance)
4	8	GND	—	P	The ground reference for the device.
5	9	RST	O	Push Pull	Reset Output (Active-High) Goes active (High) if one of these conditions occurs: 1. If V <sub>CC</sub> falls below the selected Reset voltage threshold. 2. If PB RST pin is forced low. 3. If ST pin is not strobed within the minimum selected time-out period. (see TD pin) 4. During power-up.
6	11	RST	O	Open Drain	Reset Output (Active-Low) Goes active (Low) if one of these conditions occurs: 1. If V <sub>CC</sub> falls below the selected Reset voltage threshold. 2. If PB RST pin is forced low. 3. If ST pin is not strobed within the minimum selected time-out period. (see TD pin) 4. During power-up.
7	13	ST	I	ST	Strobe Input Input for Watchdog Timer. WDT period determined by state of TD pin Falling Edge → Resets Watchdog Timer counter (no time-out)
8	15	V <sub>CC</sub>	—	P	The positive supply (+5V) for the device.
—	1,3,5,7,10,12,16	NC	—	—	No internal connection.

## 4.0 OPERATIONAL DESCRIPTION

### 4.1 Power Monitor

The TC1232 provides the function of warning the processor of a power failure. When  $V_{CC}$  is detected as being below the voltage levels defined by the TOL pin, the TC1232's comparator outputs the RST and  $\overline{\text{RST}}$  signals to a logic level that warns the system of an out-of-tolerance power supply. The RST and  $\overline{\text{RST}}$  signals switch at a threshold value of 4.5V if TOL is tied to  $V_{CC}$ , and at a value of 4.75V if TOL is grounded. The RST and  $\overline{\text{RST}}$  signals are held active for a minimum of 250 ms to ensure that the power supply voltage has been stabilized.

Figure 4-1 shows the  $V_{CC}$  fall time.

Figure 4-2 shows the  $V_{CC}$  rise time.

Figure 4-3 shows the time from when the voltage trip point is detected to the Reset output pin going active.

Figure 4-4 shows the time from when the voltage trip point is exited to the Reset output pin going inactive.

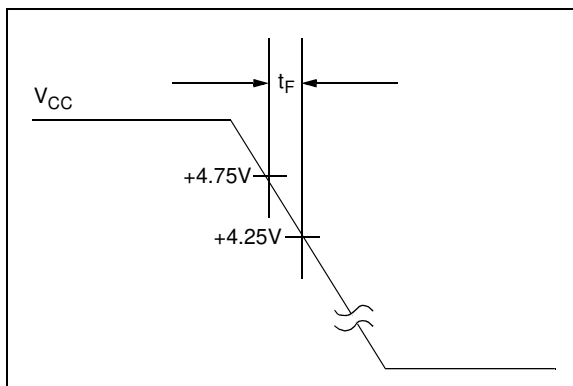

**FIGURE 4-1:** Power-Down Slew Rate.

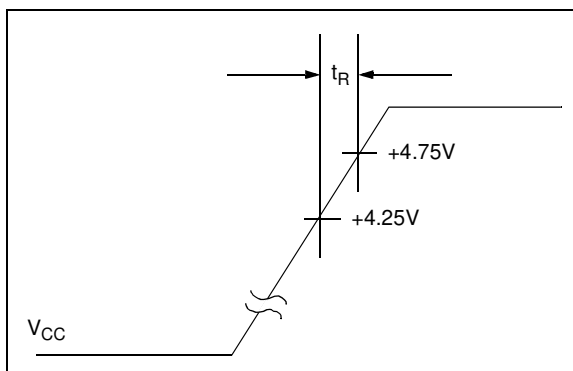

**FIGURE 4-2:** Power-up Slew Rate.

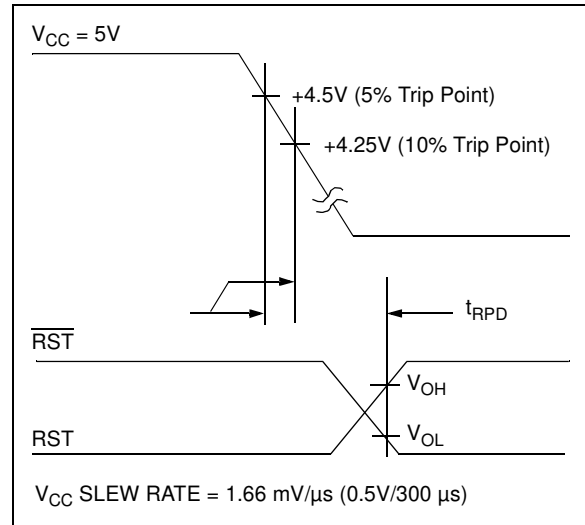

**FIGURE 4-3:**  $V_{CC}$  Detect Reset Output Delay (Power-Down).  
 $V_{CC}$  SLEW RATE = 1.66 mV/ $\mu$ s (0.5V/300  $\mu$ s)

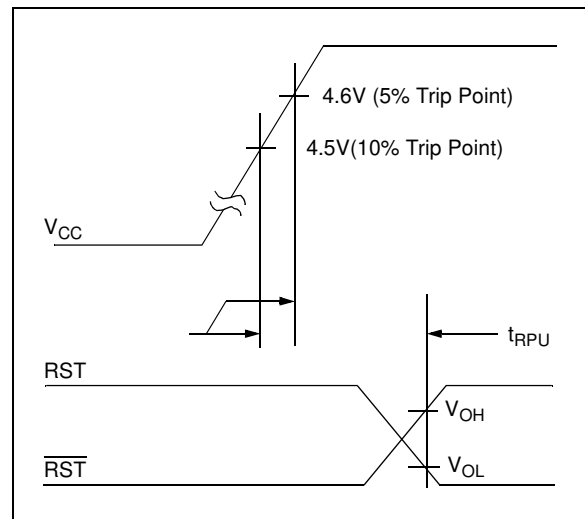

**FIGURE 4-4:**  $V_{CC}$  Detect Reset Output Delay (Power-Up).

## 4.2 Push Button Reset Input

The debounced manual Reset input ( $\overline{\text{PB RST}}$ ) manually forces the Reset outputs into their active states. Figure 4-5 shows a block diagram for using the TC1232 with a push button switch.

Once  $\overline{\text{PB RST}}$  has been low for a time  $t_{\text{PBD}}$  (the push button delay time), the Reset outputs go active. The Reset outputs remain in their active states for a minimum of 250 ms after  $\overline{\text{PB RST}}$  rises above  $V_{\text{IH}}$ . Figure 4-6 shows a waveform for the push button switch input and the Reset pins output.

A mechanical push button or active logic signal can drive the  $\overline{\text{PB RST}}$  input. The debounced input ignores input pulses less than 1 ms and recognizes pulses of 20 ms or greater. No external pull-up resistor is required because the  $\overline{\text{PB RST}}$  input has an internal pull-up to  $V_{\text{CC}}$  of approximately 100  $\mu\text{A}$ .

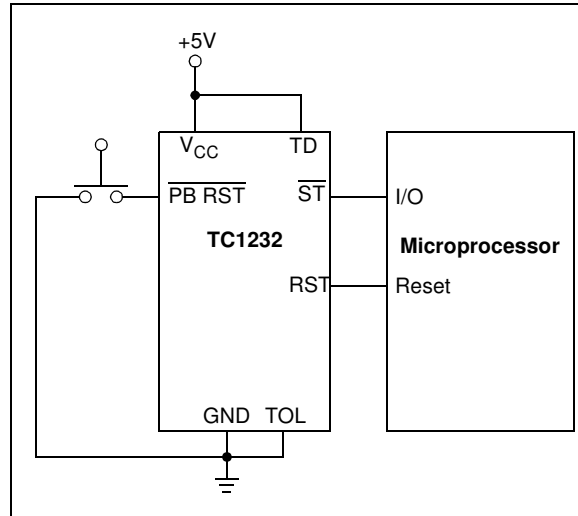

**FIGURE 4-5:** Push Button Reset and Watchdog Timer.

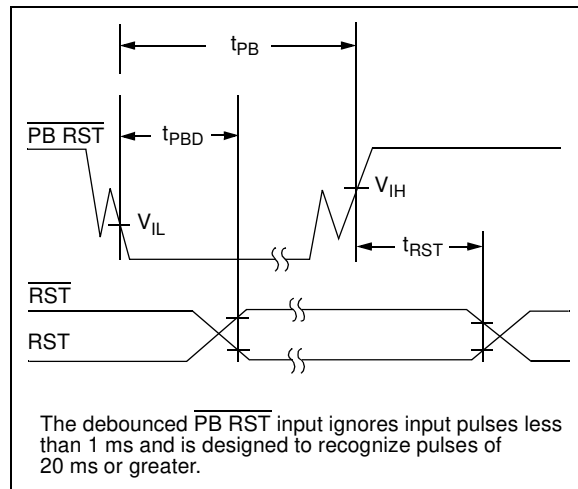

**FIGURE 4-6:** Push Button Reset –  $\overline{\text{PB RST}}$  Input.



## 4.3 Watchdog Timer

When the  $\overline{ST}$  input is not stimulated for a preset time period, the Watchdog Timer function forces RST and  $\overline{RST}$  signals to the active state. The preset time period is determined by the  $\overline{TD}$  inputs to be 150 ms with TD connected to ground, 600 ms with TD floating or 1200 ms with TD connected to  $V_{CC}$  (typ.). The Watchdog Timer starts timing-out from the set time period as soon as RST and  $\overline{RST}$  are inactive. If a high-to-low transition occurs on the  $\overline{ST}$  input pin prior to time-out, the Watchdog Timer is reset and begins to time-out again. If the Watchdog Timer is allowed to time-out, the RST and  $\overline{RST}$  signals are driven to the active state for 250 ms, minimum (Figure 4-7).

The software routine that strobes  $\overline{ST}$  is critical. The code must be in a section of software that is executed frequently enough so the time between toggles is less than the Watchdog Time-out period. One common technique controls the microprocessor I/O line from two sections of the program. The software might set the I/O line high while operating in the Foreground mode and set it low while in the Background or Interrupt modes. If both modes do not execute correctly, the Watchdog Timer issues Reset pulses.

$t_{TD}$  is the maximum elapsed time between  $\overline{ST}$  high-to-low transitions ( $\overline{ST}$  is activated by falling edges only), which will keep the Watchdog Timer from forcing the Reset outputs active for a time of  $t_{RST}$ .  $t_{TD}$  is a function of the voltage at the TD pin, as tabulated below:

**TABLE 4-1: WATCHDOG TIMER PERIODS**

Condition	$t_{TD}$		
	Min.	Typ.	Max.
TD pin = 0V	62.5 ms	150 ms	250 ms
TD pin = Open	250 ms	600 ms	1000 ms
TD pin = $V_{CC}$	500 ms	1200 ms	2000 ms

Figure 4-7 shows a block diagram for using the TC1232 with a PIC® MCU and the Watchdog input.

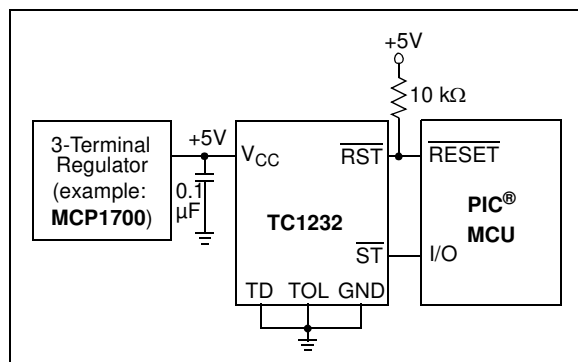

**FIGURE 4-7: Watchdog Timer.**

Figure 4-8 shows the expected Reset output pin waveforms depending on the period of the  $\overline{ST}$  pin falling edge and the state of the TD input pin.

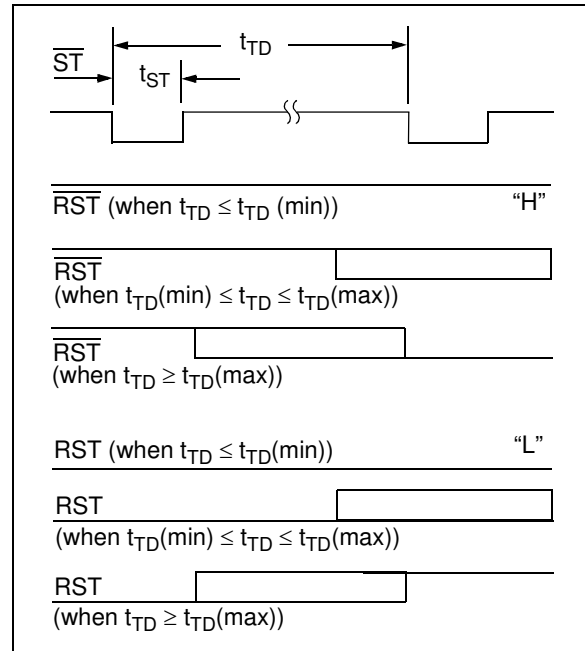

**FIGURE 4-8: Strobe Input.**

## 4.4 Supply Monitor Noise Sensitivity

The TC1232 is optimized for fast response to negative-going changes in  $V_{DD}$ . Systems with an inordinate amount of electrical noise on  $V_{DD}$  (such as systems using relays) may require a 0.01  $\mu\text{F}$  or 0.1  $\mu\text{F}$  bypass capacitor to reduce detection sensitivity. This capacitor should be installed as close to the TC1232 as possible to keep the capacitor lead length short.

# TC1232

## 5.0 PACKAGING INFORMATION

### 5.1 Package Marking Information

8-Lead PDIP (300 mil)

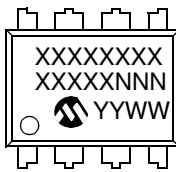

Examples:

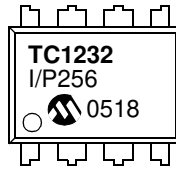

OR

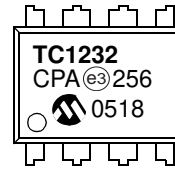

8-Lead SOIC (150 mil)

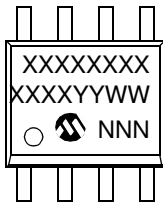

Examples:



OR

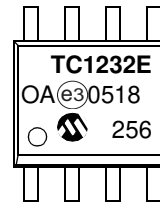

16-Lead SOIC (150 mil)

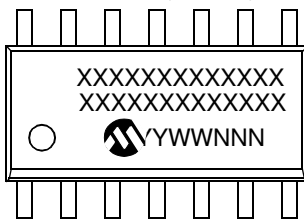

Examples:

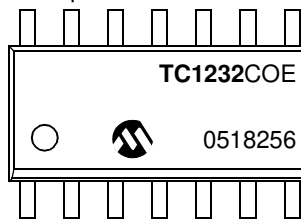

OR

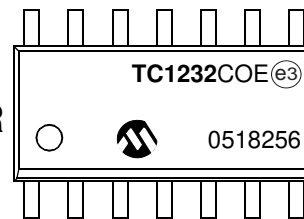

<b>Legend:</b>	XX...X	Customer-specific information
	Y	Year code (last digit of calendar year)
	YY	Year code (last 2 digits of calendar year)
	WW	Week code (week of January 1 is week '01')
	NNN	Alphanumeric traceability code
	(e3)	Pb-free JEDEC® designator for Matte Tin (Sn)
	*	This package is Pb-free. The Pb-free JEDEC designator (e3) can be found on the outer packaging for this package.

**Note:** In the event the full Microchip part number cannot be marked on one line, it will be carried over to the next line, thus limiting the number of available characters for customer-specific information.

## 8-Lead Plastic Dual In-Line (PA) – 300 mil Body [PDIP]

**Note:** For the most current package drawings, please see the Microchip Packaging Specification located at <http://www.microchip.com/packaging>

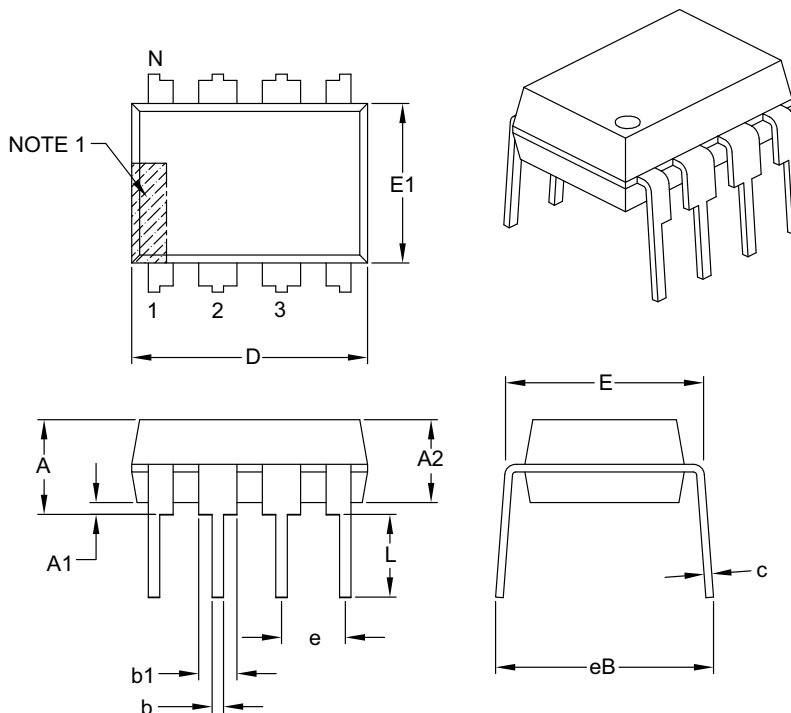

Dimension Limits	Units	INCHES		
		MIN	NOM	MAX
Number of Pins	N	8		
Pitch	e	.100 BSC		
Top to Seating Plane	A	–	–	.210
Molded Package Thickness	A2	.115	.130	.195
Base to Seating Plane	A1	.015	–	–
Shoulder to Shoulder Width	E	.290	.310	.325
Molded Package Width	E1	.240	.250	.280
Overall Length	D	.348	.365	.400
Tip to Seating Plane	L	.115	.130	.150
Lead Thickness	c	.008	.010	.015
Upper Lead Width	b1	.040	.060	.070
Lower Lead Width	b	.014	.018	.022
Overall Row Spacing §	eB	–	–	.430

**Notes:**

1. Pin 1 visual index feature may vary, but must be located with the hatched area.
2. § Significant Characteristic.
3. Dimensions D and E1 do not include mold flash or protrusions. Mold flash or protrusions shall not exceed .010" per side.
4. Dimensioning and tolerancing per ASME Y14.5M.  
BSC: Basic Dimension. Theoretically exact value shown without tolerances.

Microchip Technology Drawing C04-018B

# TC1232

## 8-Lead Plastic Small Outline (OA) - Narrow, 3.90 mm Body [SOIC]

**Note:** For the most current package drawings, please see the Microchip Packaging Specification located at <http://www.microchip.com/packaging>

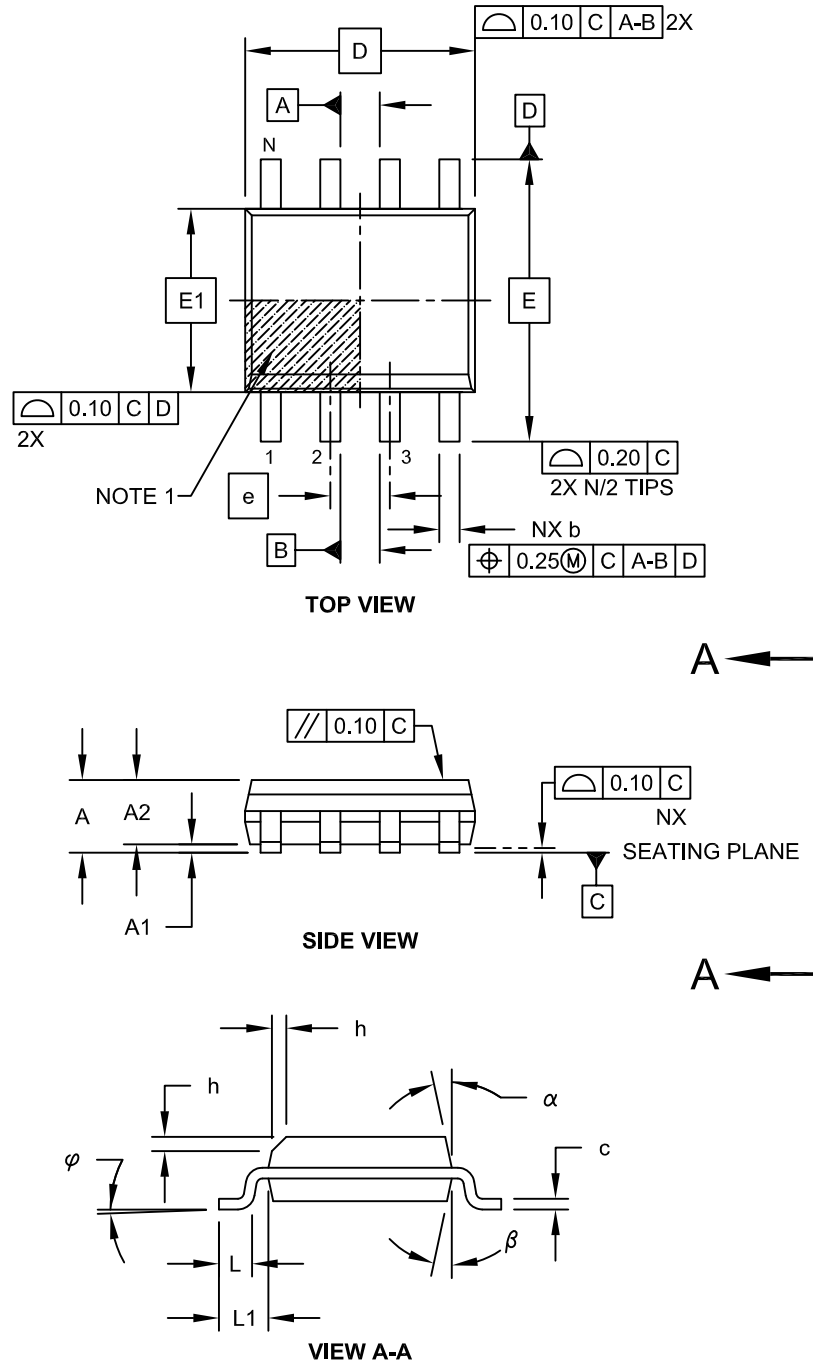

Microchip Technology Drawing No. C04-057C Sheet 1 of 2

## 8-Lead Plastic Small Outline (OA) - Narrow, 3.90 mm Body [SOIC]

**Note:** For the most current package drawings, please see the Microchip Packaging Specification located at <http://www.microchip.com/packages>

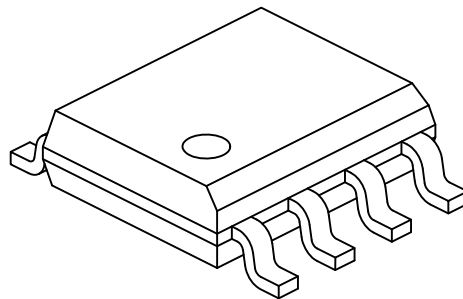

Dimension	Units	MILLIMETERS		
		MIN	NOM	MAX
Number of Pins	N	8		
Pitch	e	1.27 BSC		
Overall Height	A	-	-	1.75
Molded Package Thickness	A2	1.25	-	-
Standoff §	A1	0.10	-	0.25
Overall Width	E	6.00 BSC		
Molded Package Width	E1	3.90 BSC		
Overall Length	D	4.90 BSC		
Chamfer (Optional)	h	0.25	-	0.50
Foot Length	L	0.40	-	1.27
Footprint	L1	1.04 REF		
Foot Angle	$\varphi$	0°	-	8°
Lead Thickness	c	0.17	-	0.25
Lead Width	b	0.31	-	0.51
Mold Draft Angle Top	$\alpha$	5°	-	15°
Mold Draft Angle Bottom	$\beta$	5°	-	15°

**Notes:**

1. Pin 1 visual index feature may vary, but must be located within the hatched area.
2. § Significant Characteristic
3. Dimensions D and E1 do not include mold flash or protrusions. Mold flash or protrusions shall not exceed 0.15mm per side.
4. Dimensioning and tolerancing per ASME Y14.5M

BSC: Basic Dimension. Theoretically exact value shown without tolerances.

REF: Reference Dimension, usually without tolerance, for information purposes only.

Microchip Technology Drawing No. C04-057C Sheet 2 of 2

# TC1232

## 8-Lead Plastic Small Outline (OA) – Narrow, 3.90 mm Body [SOIC]

**Note:** For the most current package drawings, please see the Microchip Packaging Specification located at <http://www.microchip.com/packaging>

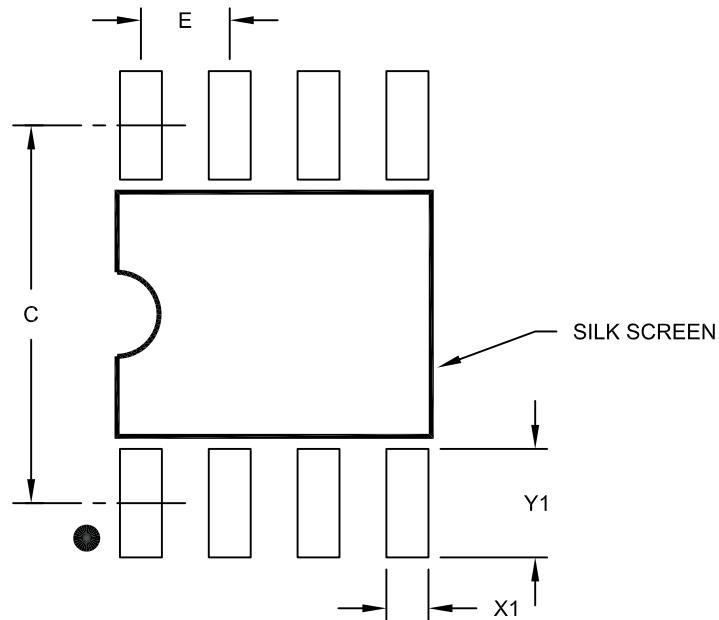

RECOMMENDED LAND PATTERN

Dimension Limits	Units	MILLIMETERS		
		MIN	NOM	MAX
Contact Pitch	E	1.27 BSC		
Contact Pad Spacing	C		5.40	
Contact Pad Width (X8)	X1			0.60
Contact Pad Length (X8)	Y1			1.55

Notes:

1. Dimensioning and tolerancing per ASME Y14.5M

BSC: Basic Dimension. Theoretically exact value shown without tolerances.

Microchip Technology Drawing No. C04-2057A

## 16-Lead Plastic Small Outline (OE) - Wide, 7.50 mm Body [SOIC]

**Note:** For the most current package drawings, please see the Microchip Packaging Specification located at <http://www.microchip.com/packaging>

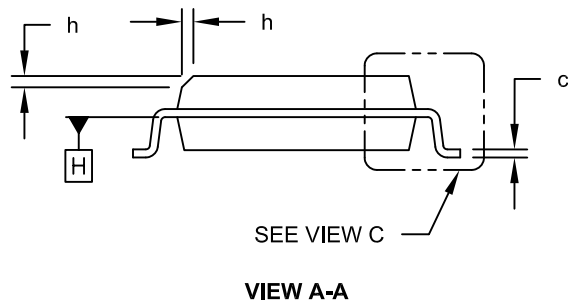
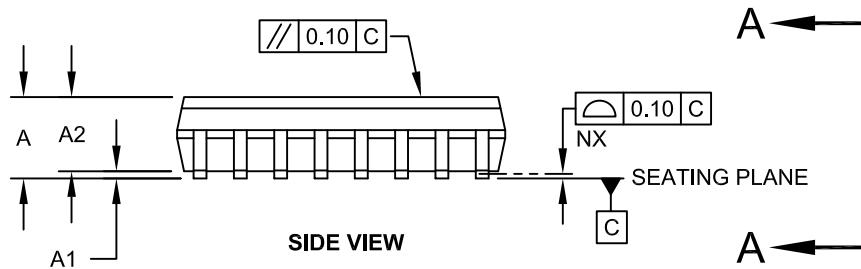
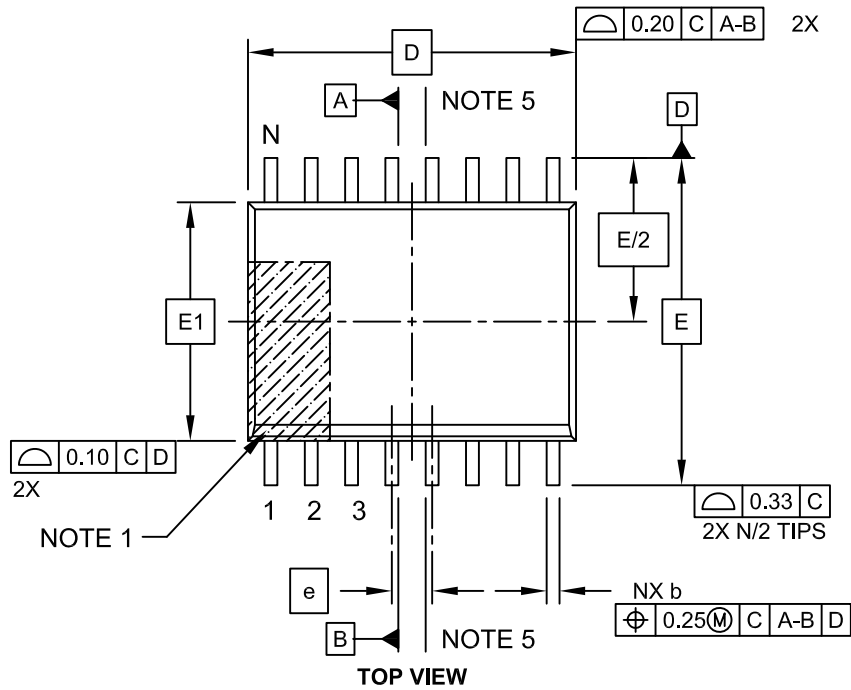

Microchip Technology Drawing C04-102C Sheet 1 of 2

# TC1232

## 16-Lead Plastic Small Outline (OE) - Wide, 7.50 mm Body [SOIC]

**Note:** For the most current package drawings, please see the Microchip Packaging Specification located at <http://www.microchip.com/packaging>

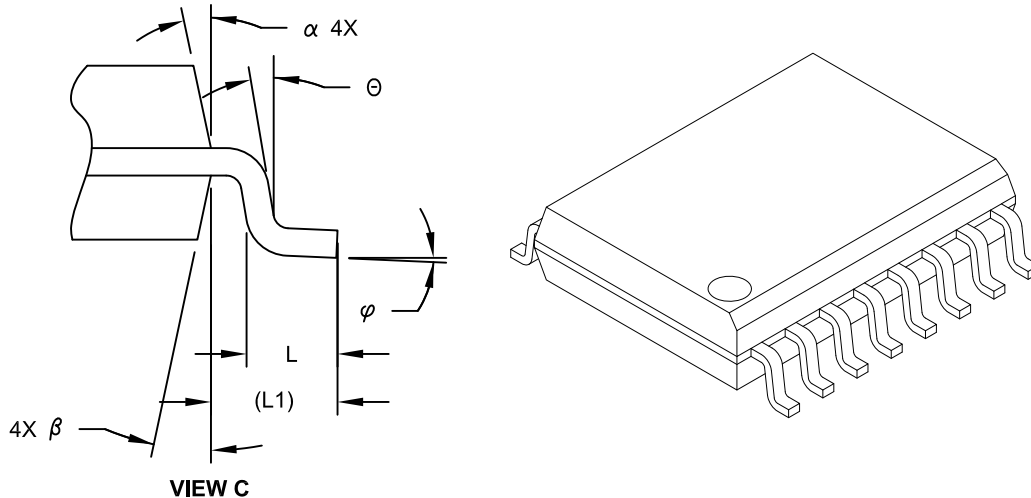

Dimension Limits	Units	MILLIMETERS		
		MIN	NOM	MAX
Number of Pins	N	16		
Pitch	e	1.27 BSC		
Overall Height	A	-	-	2.65
Molded Package Thickness	A2	2.05	-	-
Standoff §	A1	0.10	-	0.30
Overall Width	E	10.30 BSC		
Molded Package Width	E1	7.50 BSC		
Overall Length	D	10.30 BSC		
Chamfer (Optional)	h	0.25	-	0.75
Foot Length	L	0.40	-	1.27
Footprint	L1	1.40 REF		
Lead Angle	$\theta$	0°	-	-
Foot Angle	$\varphi$	0°	-	8°
Lead Thickness	c	0.20	-	0.33
Lead Width	b	0.31	-	0.51
Mold Draft Angle Top	$\alpha$	5°	-	15°
Mold Draft Angle Bottom	$\beta$	5°	-	15°

**Notes:**

- Pin 1 visual index feature may vary, but must be located within the hatched area.
- § Significant Characteristic
- Dimension D does not include mold flash, protrusions or gate burrs, which shall not exceed 0.15 mm per end. Dimension E1 does not include interlead flash or protrusion, which shall not exceed 0.25 mm per side.
- Dimensioning and tolerancing per ASME Y14.5M  
 BSC: Basic Dimension. Theoretically exact value shown without tolerances.  
 REF: Reference Dimension, usually without tolerance, for information purposes only.
- Datums A & B to be determined at Datum H.

Microchip Technology Drawing No. C04-102C Sheet 2 of 2



## 16-Lead Plastic Small Outline (OE) – Wide, 7.50 mm Body [SOIC] Land Pattern

**Note:** For the most current package drawings, please see the Microchip Packaging Specification located at <http://www.microchip.com/packaging>

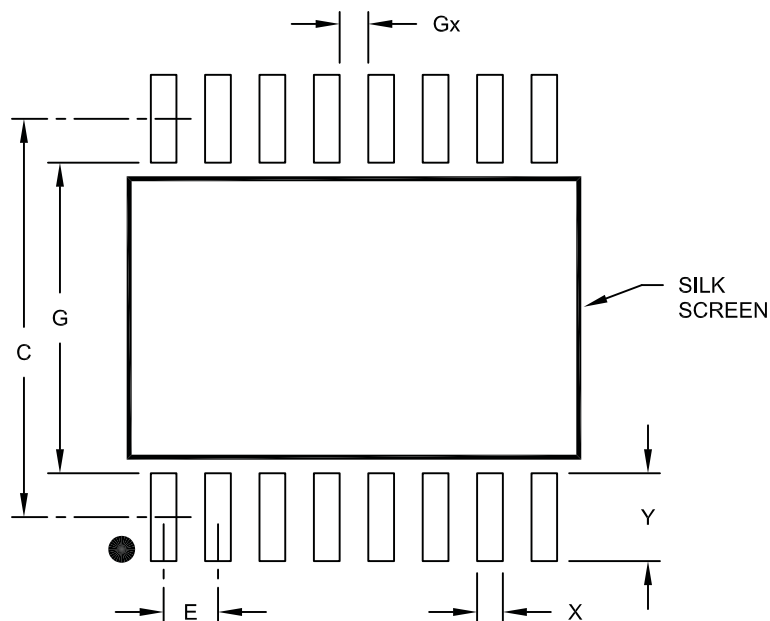

RECOMMENDED LAND PATTERN

Dimension Limits	Units	MILLIMETERS		
		MIN	NOM	MAX
Contact Pitch	E	1.27 BSC		
Contact Pad Spacing	C		9.30	
Contact Pad Width	X			0.60
Contact Pad Length	Y			2.05
Distance Between Pads	Gx	0.67		
Distance Between Pads	G	7.25		

**Notes:**

1. Dimensioning and tolerancing per ASME Y14.5M

BSC: Basic Dimension. Theoretically exact value shown without tolerances.

Microchip Technology Drawing No. C04-2102A

# TC1232

---

NOTES:

## APPENDIX A: REVISION HISTORY

### Revision E (February 2014)

- Removed the “Preliminary” watermark.

### Revision D (November 2012)

- Added a note to the package outline drawing.

### Revision C (June 2005)

The following is the list of modifications:

1. Since no data is given in [Section 2.0 “Typical Performance Curves”](#), “Preliminary” was added to the bottom of this document.
2. Corrected Operating Voltage in the Electrical Specifications.
3. General Data Sheet Enhancements.
4. Added Revision History Appendix Section.

### Revision B (March 2003)

- Not logged

### Revision A (March 2002)

- Original Release of this Document.

# TC1232

---

NOTES:

## PRODUCT IDENTIFICATION SYSTEM

To order or obtain information, e.g., on pricing or delivery, refer to the factory or the listed sales office.

<u>PART NO.</u>	<u>X</u>	<u>/XX</u>
Device	Temperature Range	Package
<b>Device:</b> TC1232: Microprocessor Monitor	<b>Temperature Range:</b> C = 0°C to +70°C E = -40°C to +85°C	<b>Package:</b> PA = Plastic DIP (300 mil Body), 8-lead OA = Plastic SOIC, (150 mil Body), 8-lead OA713 = Plastic SOIC, (150 mil Body), 8-lead Tape and Reel OE = Plastic SOIC (300 mil Body), 16-lead OE713 = Plastic SOIC (300 mil Body), 16-lead Tape and Reel
<b>Examples:</b> a) TC1232COA: 0°C to +70°C, 8L-SOIC b) TC1232COA713: 0°C to +70°C, 8L-SOIC, Tape and Reel c) TC1232COE: 0°C to +70°C, 16L-SOIC d) TC1232COE713: 0°C to +70°C, 16L-SOIC Tape and Reel e) TC1232CPA: 0°C to +70°C, 8L-PDIP f) TC1232EOA: -40°C to +85°C, 8L-SOIC g) TC1232EOA713: -40°C to +85°C, 8L-SOIC, Tape and Reel h) TC1232EOE: -40°C to +85°C, 16L-SOIC i) TC1232EOE713: -40°C to +85°C, 16L-SOIC, Tape and Reel j) TC1232EPA: -40°C to +85°C, 8L-PDIP		

# TC1232

---

NOTES:

---

**Note the following details of the code protection feature on Microchip devices:**

- Microchip products meet the specification contained in their particular Microchip Data Sheet.
- Microchip believes that its family of products is one of the most secure families of its kind on the market today, when used in the intended manner and under normal conditions.
- There are dishonest and possibly illegal methods used to breach the code protection feature. All of these methods, to our knowledge, require using the Microchip products in a manner outside the operating specifications contained in Microchip's Data Sheets. Most likely, the person doing so is engaged in theft of intellectual property.
- Microchip is willing to work with the customer who is concerned about the integrity of their code.
- Neither Microchip nor any other semiconductor manufacturer can guarantee the security of their code. Code protection does not mean that we are guaranteeing the product as “unbreakable.”

Code protection is constantly evolving. We at Microchip are committed to continuously improving the code protection features of our products. Attempts to break Microchip's code protection feature may be a violation of the Digital Millennium Copyright Act. If such acts allow unauthorized access to your software or other copyrighted work, you may have a right to sue for relief under that Act.

---

Information contained in this publication regarding device applications and the like is provided only for your convenience and may be superseded by updates. It is your responsibility to ensure that your application meets with your specifications. MICROCHIP MAKES NO REPRESENTATIONS OR WARRANTIES OF ANY KIND WHETHER EXPRESS OR IMPLIED, WRITTEN OR ORAL, STATUTORY OR OTHERWISE, RELATED TO THE INFORMATION, INCLUDING BUT NOT LIMITED TO ITS CONDITION, QUALITY, PERFORMANCE, MERCHANTABILITY OR FITNESS FOR PURPOSE. Microchip disclaims all liability arising from this information and its use. Use of Microchip devices in life support and/or safety applications is entirely at the buyer's risk, and the buyer agrees to defend, indemnify and hold harmless Microchip from any and all damages, claims, suits, or expenses resulting from such use. No licenses are conveyed, implicitly or otherwise, under any Microchip intellectual property rights.

#### **Trademarks**

The Microchip name and logo, the Microchip logo, dsPIC, FlashFlex, KEELOQ, KEELOQ logo, MPLAB, PIC, PICmicro, PICSTART, PIC<sup>32</sup> logo, rPIC, SST, SST Logo, SuperFlash and UNI/O are registered trademarks of Microchip Technology Incorporated in the U.S.A. and other countries.

FilterLab, Hampshire, HI-TECH C, Linear Active Thermistor, MTP, SEEVAL and The Embedded Control Solutions Company are registered trademarks of Microchip Technology Incorporated in the U.S.A.

Silicon Storage Technology is a registered trademark of Microchip Technology Inc. in other countries.

Analog-for-the-Digital Age, Application Maestro, BodyCom, chipKIT, chipKIT logo, CodeGuard, dsPICDEM, dsPICDEM.net, dsPICworks, dsSPEAK, ECAN, ECONOMONITOR, FanSense, HI-TIDE, In-Circuit Serial Programming, ICSP, Mindi, MiWi, MPASM, MPF, MPLAB Certified logo, MPLIB, MPLINK, mTouch, Omniscent Code Generation, PICC, PICC-18, PICDEM, PICDEM.net, PICkit, PICtail, REAL ICE, rLAB, Select Mode, SQI, Serial Quad I/O, Total Endurance, TSHARC, UniWinDriver, WiperLock, ZENA and Z-Scale are trademarks of Microchip Technology Incorporated in the U.S.A. and other countries.

SQTP is a service mark of Microchip Technology Incorporated in the U.S.A.

GestIC and ULPP are registered trademarks of Microchip Technology Germany II GmbH & Co. KG, a subsidiary of Microchip Technology Inc., in other countries.

All other trademarks mentioned herein are property of their respective companies.

© 2002-2014, Microchip Technology Incorporated, Printed in the U.S.A., All Rights Reserved.

 Printed on recycled paper.

ISBN: 978-1-62077-944-6

*Microchip received ISO/TS-16949:2009 certification for its worldwide headquarters, design and wafer fabrication facilities in Chandler and Tempe, Arizona; Gresham, Oregon and design centers in California and India. The Company's quality system processes and procedures are for its PIC<sup>®</sup> MCUs and dsPIC<sup>®</sup> DSCs, KEELOQ<sup>®</sup> code hopping devices, Serial EEPROMs, microperipherals, nonvolatile memory and analog products. In addition, Microchip's quality system for the design and manufacture of development systems is ISO 9001:2000 certified.*

**QUALITY MANAGEMENT SYSTEM  
CERTIFIED BY DNV  
= ISO/TS 16949 =**



# MICROCHIP

## Worldwide Sales and Service

### AMERICAS

**Corporate Office**  
2355 West Chandler Blvd.  
Chandler, AZ 85224-6199  
Tel: 480-792-7200  
Fax: 480-792-7277  
Technical Support:  
<http://www.microchip.com/support>  
Web Address:  
[www.microchip.com](http://www.microchip.com)

**Atlanta**  
Duluth, GA  
Tel: 678-957-9614  
Fax: 678-957-1455

**Austin, TX**  
Tel: 512-257-3370

**Boston**  
Westborough, MA  
Tel: 774-760-0087  
Fax: 774-760-0088

**Chicago**  
Itasca, IL  
Tel: 630-285-0071  
Fax: 630-285-0075

**Cleveland**  
Independence, OH  
Tel: 216-447-0464  
Fax: 216-447-0643

**Dallas**  
Addison, TX  
Tel: 972-818-7423  
Fax: 972-818-2924

**Detroit**  
Novi, MI  
Tel: 248-848-4000

**Houston, TX**  
Tel: 281-894-5983

**Indianapolis**  
Noblesville, IN  
Tel: 317-773-8323  
Fax: 317-773-5453

**Los Angeles**  
Mission Viejo, CA  
Tel: 949-462-9523  
Fax: 949-462-9608

**New York, NY**  
Tel: 631-435-6000

**San Jose, CA**  
Tel: 408-735-9110

**Canada - Toronto**  
Tel: 905-673-0699  
Fax: 905-673-6509

### ASIA/PACIFIC

**Asia Pacific Office**  
Suites 3707-14, 37th Floor  
Tower 6, The Gateway  
Harbour City, Kowloon  
Hong Kong  
Tel: 852-2401-1200  
Fax: 852-2401-3431

**Australia - Sydney**  
Tel: 61-2-9868-6733  
Fax: 61-2-9868-6755

**China - Beijing**  
Tel: 86-10-8569-7000  
Fax: 86-10-8528-2104

**China - Chengdu**  
Tel: 86-28-8665-5511  
Fax: 86-28-8665-7889

**China - Chongqing**  
Tel: 86-23-8980-9588  
Fax: 86-23-8980-9500

**China - Hangzhou**  
Tel: 86-571-2819-3187  
Fax: 86-571-2819-3189

**China - Hong Kong SAR**  
Tel: 852-2943-5100  
Fax: 852-2401-3431

**China - Nanjing**  
Tel: 86-25-8473-2460  
Fax: 86-25-8473-2470

**China - Qingdao**  
Tel: 86-532-8502-7355  
Fax: 86-532-8502-7205

**China - Shanghai**  
Tel: 86-21-5407-5533  
Fax: 86-21-5407-5066

**China - Shenyang**  
Tel: 86-24-2334-2829  
Fax: 86-24-2334-2393

**China - Shenzhen**  
Tel: 86-755-8864-2200  
Fax: 86-755-8203-1760

**China - Wuhan**  
Tel: 86-27-5980-5300  
Fax: 86-27-5980-5118

**China - Xian**  
Tel: 86-29-8833-7252  
Fax: 86-29-8833-7256

**China - Xiamen**  
Tel: 86-592-2388138  
Fax: 86-592-2388130

**China - Zhuhai**  
Tel: 86-756-3210040  
Fax: 86-756-3210049

### ASIA/PACIFIC

**India - Bangalore**  
Tel: 91-80-3090-4444  
Fax: 91-80-3090-4123

**India - New Delhi**  
Tel: 91-11-4160-8631  
Fax: 91-11-4160-8632

**India - Pune**  
Tel: 91-20-3019-1500

**Japan - Osaka**  
Tel: 81-6-6152-7160  
Fax: 81-6-6152-9310

**Japan - Tokyo**  
Tel: 81-3-6880-3770  
Fax: 81-3-6880-3771

**Korea - Daegu**  
Tel: 82-53-744-4301  
Fax: 82-53-744-4302

**Korea - Seoul**  
Tel: 82-2-554-7200  
Fax: 82-2-558-5932 or  
82-2-558-5934

**Malaysia - Kuala Lumpur**  
Tel: 60-3-6201-9857  
Fax: 60-3-6201-9859

**Malaysia - Penang**  
Tel: 60-4-227-8870  
Fax: 60-4-227-4068

**Philippines - Manila**  
Tel: 63-2-634-9065  
Fax: 63-2-634-9069

**Singapore**  
Tel: 65-6334-8870  
Fax: 65-6334-8850

**Taiwan - Hsin Chu**  
Tel: 886-3-5778-366  
Fax: 886-3-5770-955

**Taiwan - Kaohsiung**  
Tel: 886-7-213-7830

**Taiwan - Taipei**  
Tel: 886-2-2508-8600  
Fax: 886-2-2508-0102

**Thailand - Bangkok**  
Tel: 66-2-694-1351  
Fax: 66-2-694-1350

### EUROPE

**Austria - Wels**  
Tel: 43-7242-2244-39  
Fax: 43-7242-2244-393

**Denmark - Copenhagen**  
Tel: 45-4450-2828  
Fax: 45-4485-2829

**France - Paris**  
Tel: 33-1-69-53-63-20  
Fax: 33-1-69-30-90-79

**Germany - Dusseldorf**  
Tel: 49-2129-3766400

**Germany - Munich**  
Tel: 49-89-627-144-0  
Fax: 49-89-627-144-44

**Germany - Pforzheim**  
Tel: 49-7231-424750

**Italy - Milan**  
Tel: 39-0331-742611  
Fax: 39-0331-466781

**Italy - Venice**  
Tel: 39-049-7625286

**Netherlands - Drunen**  
Tel: 31-416-690399  
Fax: 31-416-690340

**Poland - Warsaw**  
Tel: 48-22-3325737

**Spain - Madrid**  
Tel: 34-91-708-08-90  
Fax: 34-91-708-08-91

**Sweden - Stockholm**  
Tel: 46-8-5090-4654

**UK - Wokingham**  
Tel: 44-118-921-5800  
Fax: 44-118-921-5820