

**DESIGNED AND DIMENSIONED
IN MILLIMETERS [INCHES]**

ERM8-XXX-XX.X-XXX-DV-XXXX-X-XX

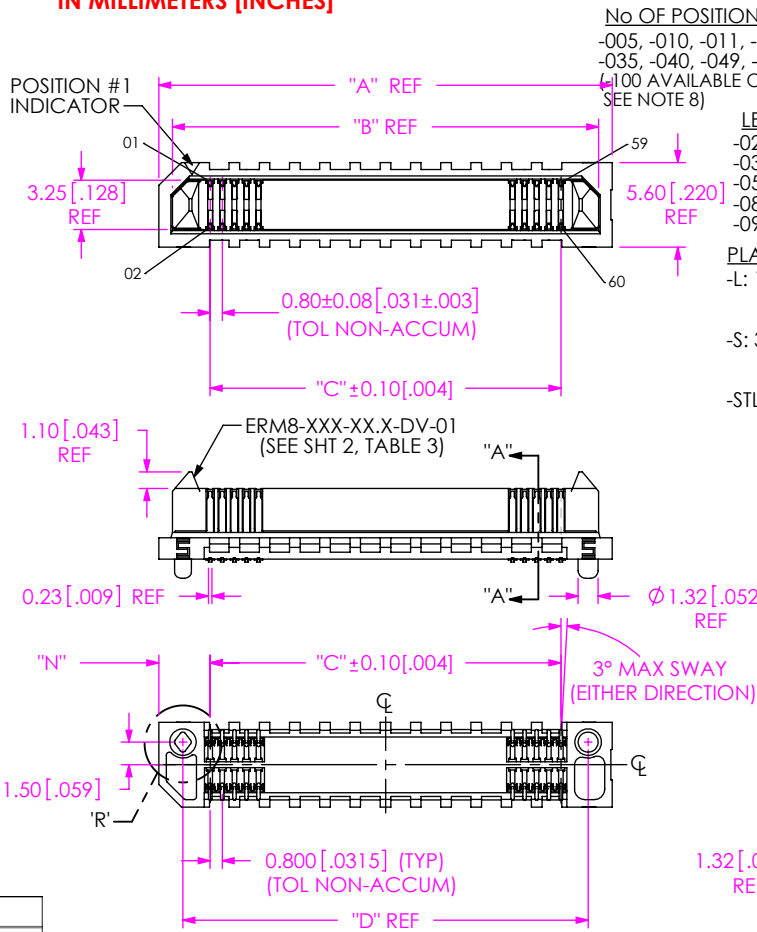

FIG 1
(ERM8-030-02.0-XXX-DV-XX SHOWN)
(SOME CENTER FEATURES REMOVED FOR CLARITY)

No OF POSITIONS (PER ROW)
-005, -010, -011, -013, -020, -025, -030,
-035, -040, -049, -050, -060, -070, -075, -100
(100 AVAILABLE ON -09.0 LEAD STYLE ONLY
SEE NOTE 8)

LEAD STYLE
-02.0 = 2mm (SEE NOTE 9)
-03.0 = 3mm (SEE NOTE 12)
-05.0 = 5mm
-08.0 = 8mm
-09.0 = 9mm

PLATING SPECIFICATION
-L: 10µ" LIGHT SELECTIVE GOLD
IN CONTACT AREA,
MATTE TIN ON TAIL
-S: 30µ" SELECTIVE GOLD
IN CONTACT AREA,
MATTE TIN ON TAIL
-STL: 30µ" SELECTIVE GOLD
IN CONTACT AREA,
TIN/LEAD (90/10+/-5%) TAIL

ROW SPECIFICATION
-DV: DOUBLE VERTICAL

PACKAGING

-TR: TAPE & REEL (SEE NOTES 7 & 9)
-FR: FULL REEL QTY. TAPE & REEL (SEE NOTE 7)
-BLANK: TRAY (SEE NOTE 7)

PICK & PLACE OPTION

-K: POLYIMIDE FILM PAD (SEE NOTE 9) (SEE FIG 2, SHT 3)
(USE K-DOT-.157-.250-.005)
-P: PICK AND PLACE PAD
(AVAILABLE ON -02.0, -03.0 AND -05.0 LEAD STYLES ONLY)
(-020 THRU -075 POSITIONS USE PPP-87) (SEE TABLE 12, SHT 6)
(-005 THRU -013 POSITIONS USE PPP-88) (SEE TABLE 12, SHT 6)
(NOT AVAILABLE WITH -DS OPTION)

OPTIONS

-DS: DIFFERENTIAL PAIR (HOT SWAP) (SEE FIG 3, SHT 2)
(AVAILABLE ONLY ON -05.0 LEAD STYLE)
(SEE TABLE 4 FOR POSITION AVAILABILITY)
-L: LATCHES (SEE FIG 3, SHT 2)
(AVAILABLE ONLY ON -03.0, -05.0 & -09.0)
(SEE TABLE FOR AVAILABILITY) (SEE TABLE 4, SHT 2)
(NOT AVAILABLE WITH -EGP & -EGPS OPTIONS)
-S: SHIELD (SEE FIG 8, SHT 5)
(NOT AVAILABLE WITH -EGP & -EGPS)
(AVAILABLE ONLY ON -02.0, -03.0, -05.0 &
-09.0 LEAD STYLES)
(-010, -020, -025 & -030-POS ONLY)
-EGP: EXTENDED GUIDE POSTS (SEE FIG 5, SHT 3)
(AVAILABLE ONLY ON -05.0 LEAD STYLE)
(NOT AVAILABLE WITH -L OPTION)
-EGPS: EXTENDED GUIDE POST SHIELD
(AVAILABLE ON -05.0 & -09.0 LEAD STYLES)
(-010, -020, -025, & -030 POS ONLY)
(NOT AVAILABLE WITH -L OPTION)
(SEE NOTE 10)
-DSP: -DS OPTION WITH -EGP: (-13 & -25 POS ONLY)
-DSS: -DS OPTION WITH -EGPS: (10 & 25 POS ONLY)

OPTION	"N"
NONE	3.40 [0.134]
-L, -EGP	4.90 [0.193]

No. OF POS.	
-005, -010, -011, -013, -020, -025, -030, -035	0.10 [0.004]
-040, -049, -050, -060	0.12 [0.005]
-070, -075, -100	0.15 [0.006]

NOTES:

1. REPRESENTS A CRITICAL DIMENSION.
2. MAXIMUM BURR ALLOWANCE: 0.038[0.015]
3. MINIMUM PUSHOUT FORCE: TERMINAL 2.22 N [.5 LB.], WELD TAB 4.45 N [1 LB.]
4. NOTE DELETED
5. "F" DIMENSION DOES NOT APPLY TO -EGP & -EGPS OPTION, SEE FIG. 5 & 6.
6. NOTE DELETED.
7. -TR/-FR PACKAGING NOT AVAILABLE ON THE 100 POSITION;
TRAY PACKAGING ONLY AVAILABLE ON -100 POSITION.
8. NOT AVAILABLE WITH -L, -EGP & -EGPS OPTIONS.
9. LEAD STYLE -02.0 & -03.0 WITH -K-TR OPTIONS AVAILABLE TO EXISTING CUSTOMERS ONLY.
10. FOR EGPS-K-TR COMBINATIONS LEAVE THE ZERO OFF THE FRONT OF THE LEAD STYLE CALLOUT.
11. C31 FOR ERM8-010-09.0-X-DV-EGPS ONLY.
12. -03.0 LEAD STYLE ONLY AVAILABLE FOR STANDARD, -L & -S OPTIONS.
13. TAPE & REEL IS STANDARD PACKAGING.
14. ORDERS WILL BE PACKAGED ACCORDING TO THE SAMTEC PACKAGING EFFICIENCY STANDARDS (SPES) FOUND ON WWW.SAMTEC.COM
15. ATTACH LABEL -4X2 TO EACH REEL.

STACK HEIGHT			
ERM8 LEAD STYLE	ERF8 LEAD STYLE		
	-05.0	-07.0	-10.0
-02.0	7.0MM	9.0MM	12.0MM
-03.0	8.0MM	10.0MM	13.0MM
-05.0	10.0MM	12.0MM	15.0MM
-08.0	13.0MM	15.0MM	18.0MM
-09.0	14.0MM	16.0MM	19.0MM

HEIGHT	"E"	"F"	"G"	"U"	"AB"
-02.0	1.605 [0.0632]	5.965 [0.2348]	5.04 [0.198]	6.765 [0.266]	6.16 [0.242]
-03.0	2.605 [0.1026]	6.965 [0.2742]	5.99 [0.236]	7.765 [0.306]	7.16 [0.282]
-05.0	4.605 [0.1813]	8.905 [0.3506]	7.98 [0.314]	9.765 [0.384]	9.16 [0.360]
-08.0	7.605 [0.2994]	11.905 [0.4687]	10.98 [0.432]	12.765 [0.503]	N/A
-09.0	8.605 [0.3388]	12.905 [0.5081]	11.98 [0.472]	13.765 [0.542]	N/A

POSITION	"A"	"B"	"C"	"D"	"H"
-005	10.00 [0.394]	8.20 [0.323]	3.20 [0.126]	6.80 [0.268]	3.00 [0.118]
-010	14.00 [0.551]	12.20 [0.480]	7.20 [0.283]	10.80 [0.425]	5.00 [0.197]
-011	14.80 [0.583]	13.00 [0.512]	8.00 [0.315]	11.60 [0.457]	5.40 [0.213]
-013	16.40 [0.646]	14.60 [0.575]	9.60 [0.378]	13.20 [0.520]	6.20 [0.244]
-020	22.00 [0.866]	20.20 [0.795]	15.20 [0.598]	18.80 [0.740]	9.00 [0.354]
-025	26.00 [1.024]	24.20 [0.953]	19.20 [0.756]	22.80 [0.898]	11.00 [0.433]
-030	30.00 [1.181]	28.20 [1.110]	23.20 [0.913]	26.80 [1.055]	13.00 [0.512]
-035	34.00 [1.339]	32.20 [1.268]	27.20 [1.071]	30.80 [1.213]	15.00 [0.591]
-040	38.00 [1.496]	36.20 [1.425]	31.20 [1.228]	34.80 [1.370]	17.00 [0.669]
-049	45.20 [1.780]	43.40 [1.709]	38.40 [1.512]	42.00 [1.654]	20.80 [0.811]
-050	46.00 [1.811]	44.20 [1.740]	39.20 [1.543]	42.80 [1.685]	21.00 [0.827]
-060	54.00 [2.126]	52.20 [2.055]	47.20 [1.858]	50.80 [2.000]	25.00 [0.984]
-070	62.00 [2.441]	60.20 [2.370]	55.20 [2.173]	58.80 [2.315]	29.00 [1.142]
-075	66.00 [2.598]	64.20 [2.528]	59.20 [2.331]	62.80 [2.472]	31.00 [1.220]
-100	86.00 [3.386]	84.20 [3.315]	79.20 [3.118]	82.80 [3.260]	41.00 [1.614]

UNLESS OTHERWISE SPECIFIED,
DIMENSIONS ARE IN
MILLIMETERS [INCHES].
TOLERANCES ARE:
DECIMALS ANGLES
X.X: ±0.3 [0.1] 2°
X.XX: ±0.13 [0.005]
X.XXX: ±0.050 [0.002]

PROPRIETARY NOTE
THIS DOCUMENT CONTAINS CONFIDENTIAL AND
PROPRIETARY INFORMATION AND ALL DESIGN,
MANUFACTURING, REPRODUCTION, USE, PATENT RIGHTS
AND SALES RIGHTS ARE EXPRESSLY RESERVED BY SAMTEC,
INC. THIS DOCUMENT SHALL NOT BE DISCLOSED, IN WHOLE
OR PART, TO ANY UNAUTHORIZED PERSON OR ENTITY NOR
REPRODUCED, TRANSFERRED OR INCORPORATED IN ANY
OTHER PROJECT IN ANY MANNER WITHOUT THE EXPRESS
WRITTEN CONSENT OF SAMTEC, INC.



520 PARK EAST BLVD. NEW ALBANY, IN 47150
PHONE: 812-944-6733 FAX: 812-948-5047
e-Mail: info@SAMTEC.com code 55322

MATERIAL: DO NOT SCALE DRAWING SHEET SCALE: 2:1
INSULATOR: LCP, COLOR: BLACK
TERMINAL: PHOS BRONZE
LATCH: BeCu
SHIELD: PHOS BRONZE

DESCRIPTION:
0.8MM EDGE RATE TERMINAL ASSEMBLY
DWG. NO.
ERM8-XXX-XX.X-XXX-DV-XXXX-X-XX

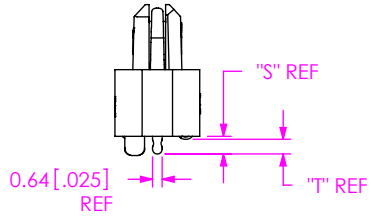
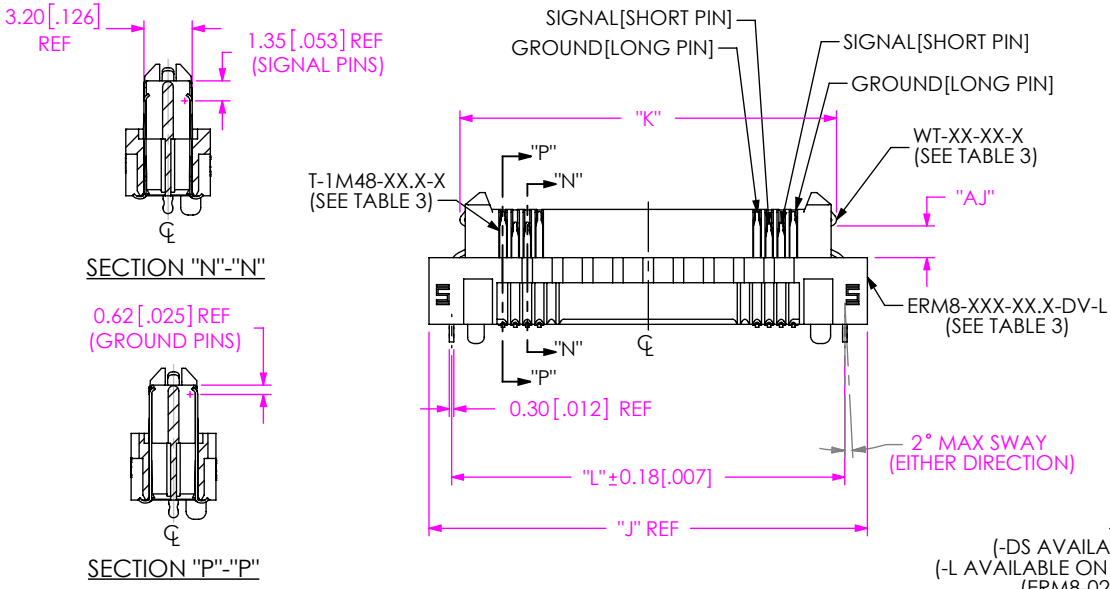
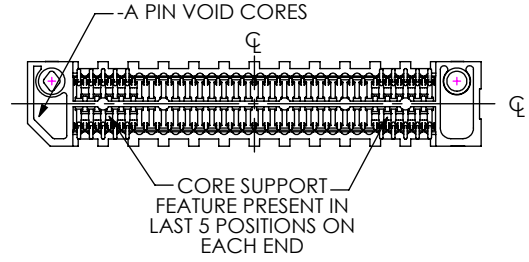
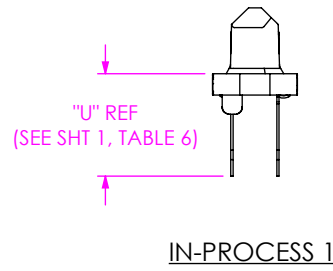
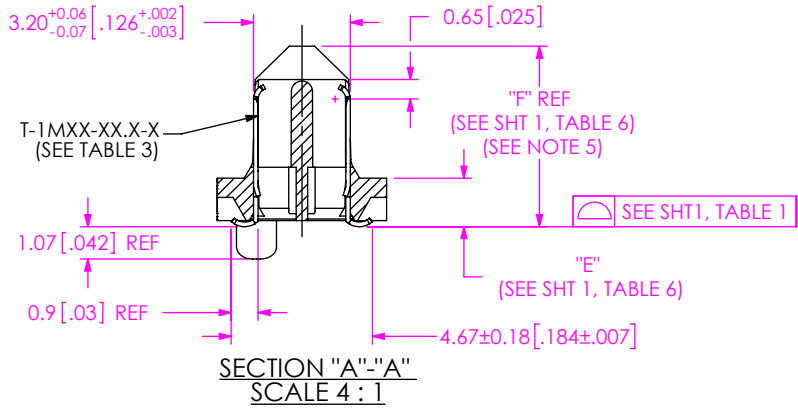

FIG 3
-DS WITH -L OPTION
(-DS AVAILABLE ON -.05.0 LEAD STYLE ONLY)
(-L AVAILABLE ON -.03.0, -.05.0 & -.09.0 LEAD STYLE ONLY)
(ERM8-025-05.0-XXX-DV-DS-L SHOWN)
(SAME AS FIG 1, EXCEPT AS SHOWN)
(SOME CENTER FEATURES REMOVED FOR CLARITY)

TABLE 4	
-DS & -L OPTION AVAILABILITY	
(-DS AVAILABLE ON -.05.0 LEAD STYLE ONLY)	
(-L AVAILABLE ON -.03.0, -.05.0 & -.09.0 LEAD STYLE ONLY)	
POSITION	
-005	-L
-010	-DS, -L
-011	-L
-013	-DS, -L
-020	-L
-025	-DS, -L
-030	-L
-035	-L
-040	-L
-049	-DS, -L
-050	-L
-060	-L
-070	-L
-075	-L

TABLE 7				
POSITION	"J"	"K"	"L"	"M"
-005	13.00 [0.512]	8.90 [0.350]	10.00 [0.394]	4.50 [0.177]
-010	17.00 [0.669]	12.90 [0.508]	14.00 [0.551]	6.50 [0.256]
-011	17.80 [0.701]	13.70 [0.539]	14.80 [0.583]	6.90 [0.272]
-013	19.40 [0.764]	15.30 [0.602]	16.40 [0.648]	7.70 [0.303]
-020	25.00 [0.984]	20.90 [0.823]	22.00 [0.866]	10.50 [0.413]
-025	29.00 [1.142]	24.90 [0.980]	26.00 [1.024]	12.50 [0.492]
-030	33.00 [1.299]	28.90 [1.138]	30.00 [1.181]	14.50 [0.571]
-035	37.00 [1.457]	32.90 [1.295]	34.00 [1.339]	16.50 [0.650]
-040	41.00 [1.614]	36.90 [1.453]	38.00 [1.496]	18.50 [0.728]
-049	48.20 [1.898]	44.10 [1.736]	45.20 [1.780]	22.10 [0.870]
-050	49.00 [1.929]	44.90 [1.768]	46.00 [1.811]	22.50 [0.886]
-060	57.00 [2.244]	52.90 [2.083]	54.00 [2.128]	26.50 [1.043]
-070	65.00 [2.559]	60.90 [2.398]	62.00 [2.441]	30.50 [1.201]
-075	69.00 [2.717]	64.90 [2.555]	66.00 [2.598]	32.50 [1.280]

TABLE 3							
OPTION	STYLE	ERM8-XXX-XX.X-DV-01	T-1MXX-XX.X-X	WT-XX-XX-X	"S"	"T"	"A"
NONE	-02.0	ERM8-XXX-02.0-DV-01	T-1M37-02.0-X				
	-03.0	ERM8-XXX-03.0-DV-01	T-1M37-03.0-X				
	-05.0	ERM8-XXX-05.0-DV-01	T-1M37-05.0-X				
	-08.0	ERM8-XXX-08.0-DV-01	T-1M37-08.0-X				
	-09.0	ERM8-XXX-09.0-DV-01	T-1M37-09.0-X				
-DS		ERM8-XXX-05.0-DV-XX	T-1M48-05.0-X				
-EGP	-05.0	ERM8-XXX-05.0-DV-EGP	T-1M37-05.0-X	WT-29-06-T	1.17 [.046]	0.97 [.038]	
-EGPS		ERM8-XXX-05.0-DV-EGPS	T-1M37-05.0-X	SH29-XX-02	1.17 [.046]	0.97 [.038]	N/A
-EGPS	-09.0	ERM8-XXX-09.0-DV-EGPS	T-1M37-09.0-X	SH29-XX-06	1.17 [.046]	0.97 [.038]	
-L	-03.0	ERM8-XXX-03.0-DV-L	T-1M37-03.0-X	WT-121-01-F	1.60 [.063]	1.40 [.055]	2.20 [.087]
	-05.0	ERM8-XXX-05.0-DV-L	T-1M37-05.0-X	WT-29-03-F	1.17 [.046]	0.97 [.038]	2.10 [.082]
	-09.0	ERM8-XXX-09.0-DV-L	T-1M37-09.0-X	WT-29-10-F	1.60 [.063]	1.40 [.055]	2.10 [.082]
-S	-02.0	ERM8-XXX-02.0-DV-S	T-1M37-02.0-X	SH29-XX-08	1.61 [.063]	1.41 [.056]	
	-03.0	ERM8-XXX-03.0-DV-S	T-1M37-03.0-X	SH122-XX-01	1.61 [.063]	1.41 [.056]	
	-05.0	ERM8-XXX-05.0-DV-S	T-1M37-05.0-X	SH29-XX-02	1.17 [.046]	0.97 [.038]	
	-09.0	ERM8-XXX-09.0-DV-S	T-1M37-09.0-X	SH29-XX-06	1.17 [.046]	0.97 [.038]	N/A

PROPRIETARY NOTE
THIS DOCUMENT CONTAINS CONFIDENTIAL AND PROPRIETARY INFORMATION AND ALL DESIGN, MANUFACTURING, REPRODUCTION, USE, PATENT RIGHTS AND SALES RIGHTS ARE EXPRESSLY RESERVED BY SAMTEC, INC. THIS DOCUMENT SHALL NOT BE DISCLOSED, IN WHOLE OR PART, TO ANY UNAUTHORIZED PERSON OR ENTITY NOR REPRODUCED, TRANSFERRED OR INCORPORATED IN ANY OTHER PROJECT IN ANY MANNER WITHOUT THE EXPRESS WRITTEN CONSENT OF SAMTEC, INC.

DO NOT SCALE DRAWING
SHEET SCALE: 2:1



520 PARK EAST BLVD. NEW ALBANY, IN 47150
PHONE: 812-944-6733 FAX: 812-948-5047
e-Mail info@SAMTEC.com code 55322

DESCRIPTION:
0.8MM EDGE RATE TERMINAL ASSEMBLY
DWG. NO.
ERM8-XXX-XX.X-XXX-DV-XXXX-X-XX
BY: KNOWLDEN 9/27/2005 SHEET 2 OF 7

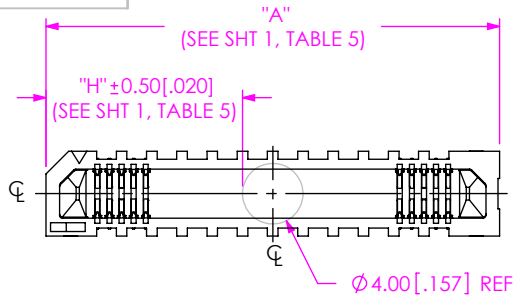

FIG 2
-K OPTION
(ERM8-030-XX.X-XXX-DV-K SHOWN)
(SOME CENTER FEATURES REMOVED FOR CLARITY)

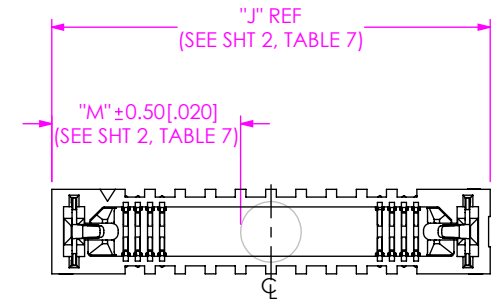
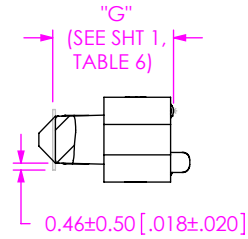
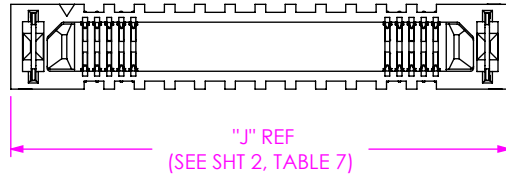

FIG 4
-K WITH -L OPTION
(ERM8-025-05.0-XXX-DV-L-K SHOWN)
(SAME AS FIG 2, EXCEPT AS SHOWN)
(SOME CENTER FEATURES REMOVED FOR CLARITY)



ERM8-XXX-05.0-DV-EGP
(SEE SHT 2, TABLE 3)

WT-XX-XX-X
(SEE SHT 2, TABLE 3)

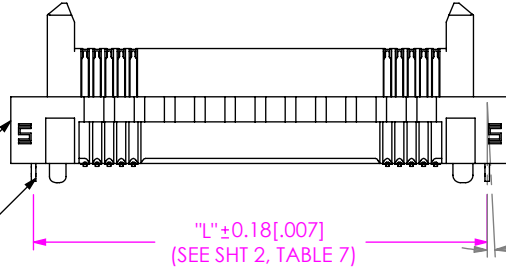
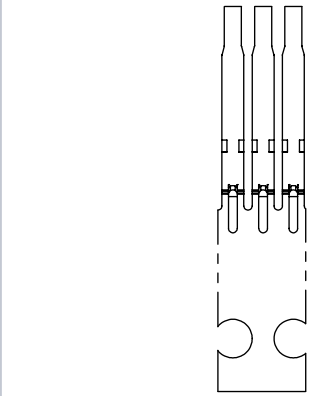
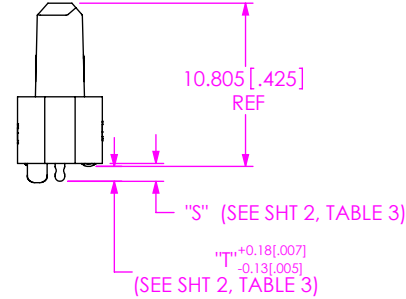

FIG 5
-EGP OPTION
(AVAILABLE ON -05.0 LEAD STYLE ONLY)
(ERM8-030-05.0-XXX-DV-EGP SHOWN)
(SAME AS FIG 3, EXCEPT AS SHOWN)
(SOME CENTER FEATURES REMOVED FOR CLARITY)



T-1M37-XX.X-X
IN-PROCESS VIEW

PROPRIETARY NOTE

THIS DOCUMENT CONTAINS CONFIDENTIAL AND PROPRIETARY INFORMATION AND ALL DESIGN, MANUFACTURING, REPRODUCTION, USE, PATENT RIGHTS AND SALES RIGHTS ARE EXPRESSLY RESERVED BY SAMTEC, INC. THIS DOCUMENT SHALL NOT BE DISCLOSED, IN WHOLE OR PART, TO ANY UNAUTHORIZED PERSON OR ENTITY NOR REPRODUCED, TRANSFERRED OR INCORPORATED IN ANY OTHER PROJECT IN ANY MANNER WITHOUT THE EXPRESS WRITTEN CONSENT OF SAMTEC, INC.

DO NOT SCALE DRAWING

SHEET SCALE: 2:1



520 PARK EAST BLVD, NEW ALBANY, IN 47150
PHONE: 812-944-6733 FAX: 812-948-5047
e-Mail info@SAMTEC.com code 55322

DESCRIPTION:
0.8MM EDGE RATE TERMINAL ASSEMBLY

DWG. NO.
ERM8-XXX-XX.X-XXX-DV-XXXX-X-XX

BY: KNOWLDEN 9/27/2005 SHEET 3 OF 7

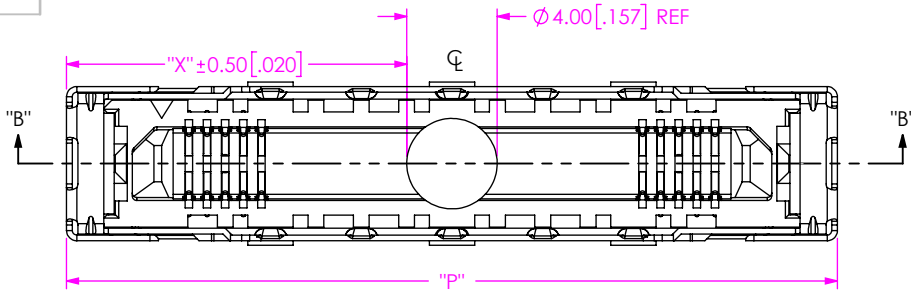

ERM8-XXX-05.0-DV-EGPS
(SEE SHT 2, TABLE 3)

SH29-XX-02-X

0.64 [0.025]
REF (TYP)

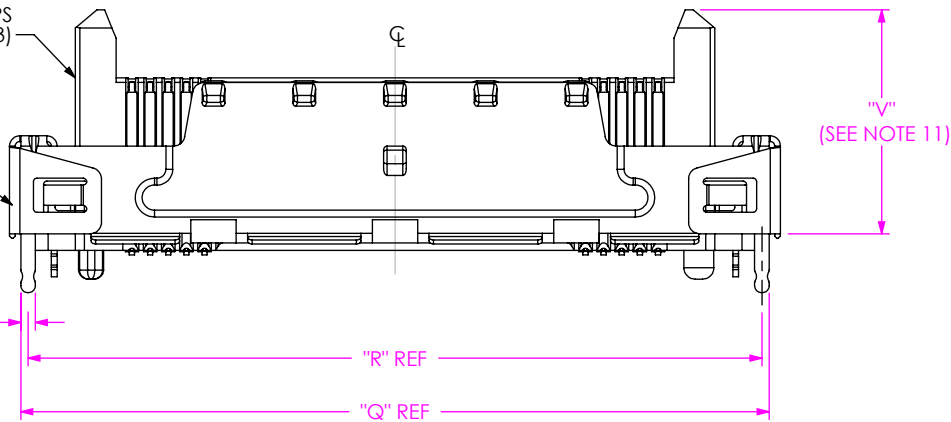

0.25 [0.010]
(TYP) REF

"L" ± 0.18 [0.007]
(SEE SHT 2, TABLE 7)

2° MAX SWAY
(EITHER DIRECTION)

No. OF POS.	"P"	"Q"	"R"	"X"
-10	18.0 [0.71]	17.00 [0.669]	16.36 [0.644]	7.00 [0.276]
-20	26.0 [1.02]	25.00 [0.984]	24.36 [0.959]	11.00 [0.433]
-25	30.0 [1.18]	29.00 [1.142]	28.36 [1.117]	13.00 [0.512]
-30	34.0 [1.34]	33.00 [1.299]	32.36 [1.274]	15.00 [0.591]

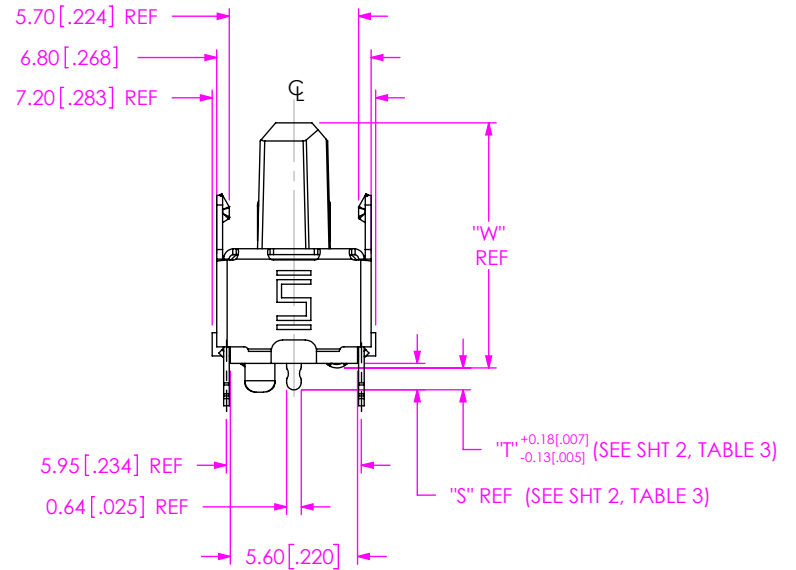

LEAD STYLE	"V"	"W"
-05.0	9.87 [0.389]	10.805 [0.4254]
-09.0	13.87 [0.546]	14.805 [0.5829]

FIG 6
-EGPS OPTIONS
(AVAILABLE ON -05.0 & -09.0 LEAD STYLE,
-010, -020, -025 & -030 POS)
(ERM8-030-05.0-XXX-DV-EGPS SHOWN)
(SAME AS FIG 5, EXCEPT AS SHOWN)

SECTION "B"- "B"

PROPRIETARY NOTE
THIS DOCUMENT CONTAINS CONFIDENTIAL AND PROPRIETARY INFORMATION AND ALL DESIGN, MANUFACTURING, REPRODUCTION, USE, PATENT RIGHTS AND SALES RIGHTS ARE EXPRESSLY RESERVED BY SAMTEC, INC. THIS DOCUMENT SHALL NOT BE DISCLOSED, IN WHOLE OR PART, TO ANY UNAUTHORIZED PERSON OR ENTITY NOR REPRODUCED, TRANSFERRED OR INCORPORATED IN ANY OTHER PROJECT IN ANY MANNER WITHOUT THE EXPRESS WRITTEN CONSENT OF SAMTEC, INC.

DO NOT SCALE DRAWING

SHEET SCALE: 3:1



520 PARK EAST BLVD, NEW ALBANY, IN 47150
PHONE: 812-944-6733 FAX: 812-948-5047
e-Mail: info@SAMTEC.com code 55322

DESCRIPTION:
0.8MM EDGE RATE TERMINAL ASSEMBLY

DWG. NO.
ERM8-XXX-XX.X-XXX-DV-XXXX-X-XX

BY: KNOWLDEN 9/27/2005 SHEET 4 OF 7

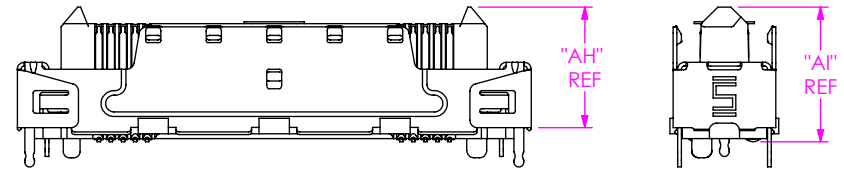
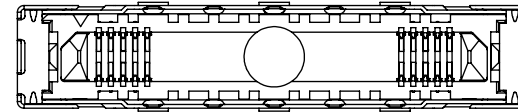
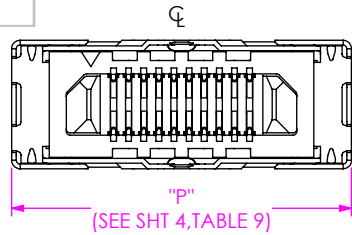

FIG 14
ERM8-030-05.0-XXX-DV-S SHOWN
(AVAILABLE ON -05.0 & -09.0 LEAD STYLE,
-010, -020, -025 & -030 POS)
(DIFFERENT AS SHOWN, OTHERWISE SAME AS FIG 6)

LEAD STYLE	"AH"	"AI"
-05.0	7.97 [.314]	8.905 [.3506]
-09.0	11.97 [.471]	12.905 [.5081]

ERM8-010-09.0-DV-EGPS
(SEE SHT 2, TABLE 3)

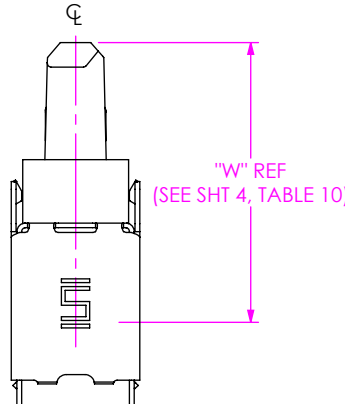
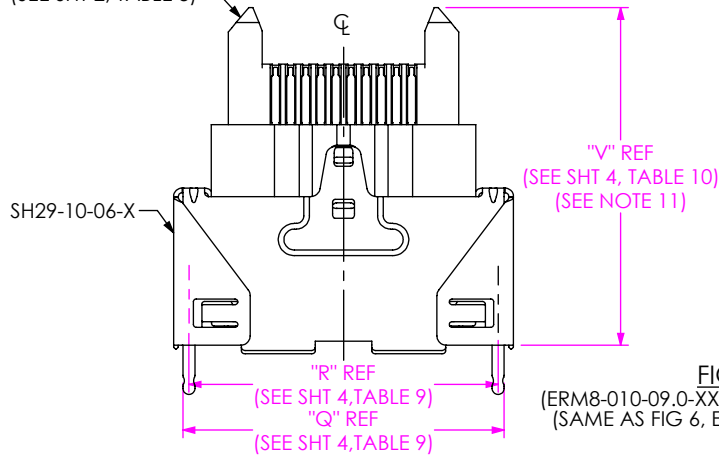
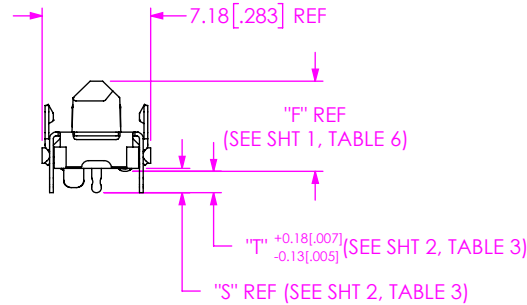
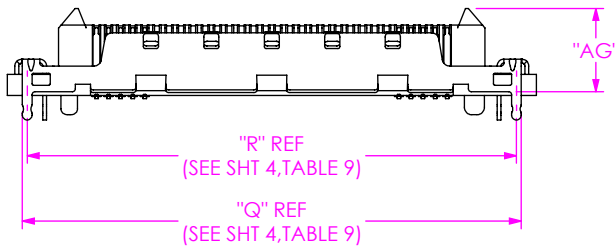
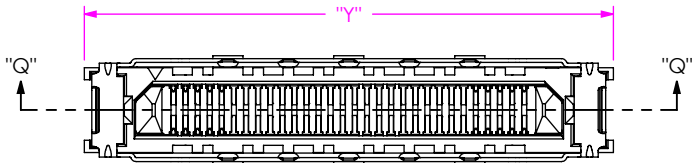
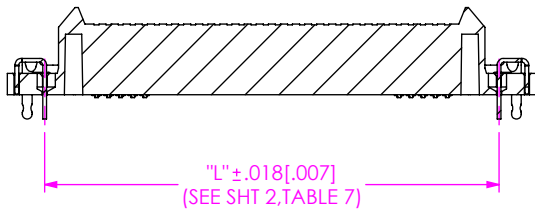

FIG 7
(ERM8-010-09.0-XXX-DV-EGPS SHOWN)
(SAME AS FIG 6, EXCEPT AS SHOWN)

No. OF POS.	"Y"
-10	19.0 [0.75]
-20	27.0 [1.06]
-25	31.0 [1.22]
-30	35.0 [1.38]



LEAD STYLE	"AG"
-02.0	5.51 [0.217]
-03.0	6.61 [0.260]



SECTION "Q"-"Q"

FIG 8
(ERM8-030-02.0-XXX-DV-S SHOWN)
(AVAILABLE ON -02.0 & -03.0 LEAD STYLE,
-010, -020, -025 & -030 POS)
(SAME AS FIG 6, EXCEPT AS SHOWN)

PROPRIETARY NOTE
THIS DOCUMENT CONTAINS CONFIDENTIAL AND PROPRIETARY INFORMATION AND ALL DESIGN, MANUFACTURING, REPRODUCTION, USE, PATENT RIGHTS AND SALES RIGHTS ARE EXPRESSLY RESERVED BY SAMTEC, INC. THIS DOCUMENT SHALL NOT BE DISCLOSED, IN WHOLE OR PART, TO ANY UNAUTHORIZED PERSON OR ENTITY NOR REPRODUCED, TRANSFERRED OR INCORPORATED IN ANY OTHER PROJECT IN ANY MANNER WITHOUT THE EXPRESS WRITTEN CONSENT OF SAMTEC, INC.

DO NOT SCALE DRAWING

SHEET SCALE: 2:1



520 PARK EAST BLVD, NEW ALBANY, IN 47150
PHONE: 812-944-6733 FAX: 812-948-5047
e-Mail info@SAMTEC.com code 55322

DESCRIPTION:
0.8MM EDGE RATE TERMINAL ASSEMBLY

DWG. NO.
ERM8-XXX-XX.X-XXX-DV-XXXX-X-XX

BY: KNOWLDEN 9/27/2005 SHEET 5 OF 7

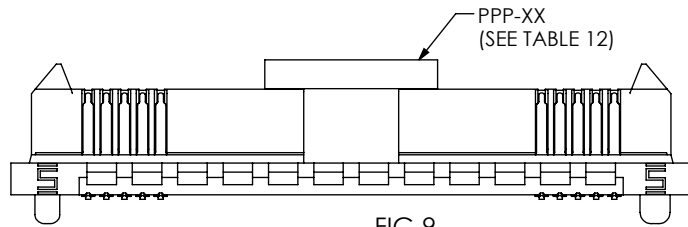
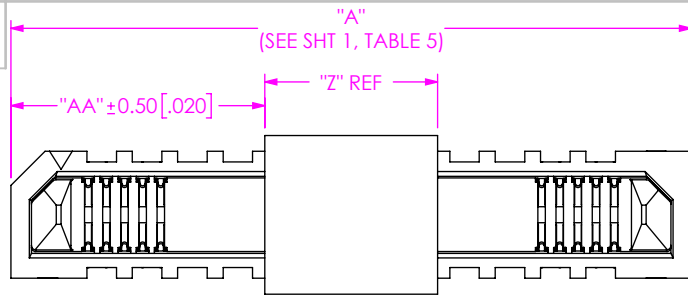

FIG 9
-P OPTION
(ERM8-030-XX.X-XXX-DV-P SHOWN)
(SAME AS FIG 1, EXCEPT AS SHOWN)
(SOME CENTER FEATURES REMOVED FOR CLARITY)

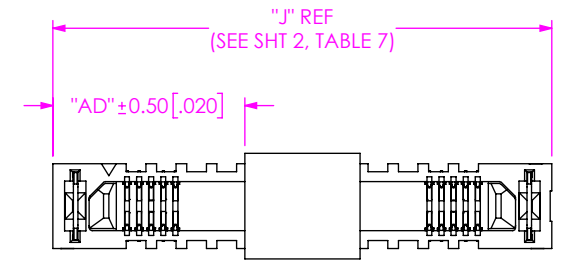
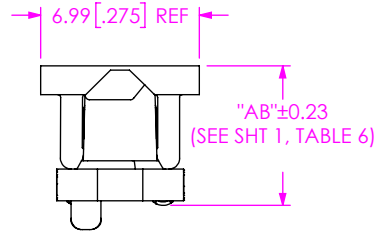

FIG 11
-P WITH -EGP OPTION
(ERM8-030-05.0-XXX-DV-EGP-P SHOWN)
(SAME AS FIG 9, EXCEPT AS SHOWN)
(SOME CENTER FEATURES REMOVED FOR CLARITY)

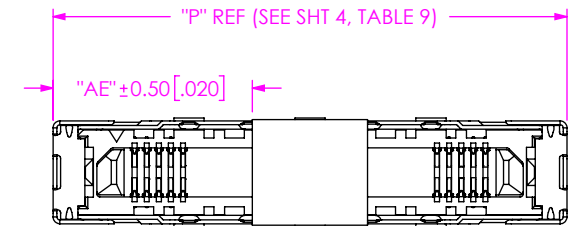

FIG 12
-P WITH -EGPS OPTION
(ERM8-030-05.0-XXX-DV-EGPS-P SHOWN)
(SAME AS FIG 9, EXCEPT AS SHOWN)
(SOME CENTER FEATURES REMOVED FOR CLARITY)
(ALSO APPLY TO -S OPTION ON -05.0 & -09.0 LEAD STYLES)

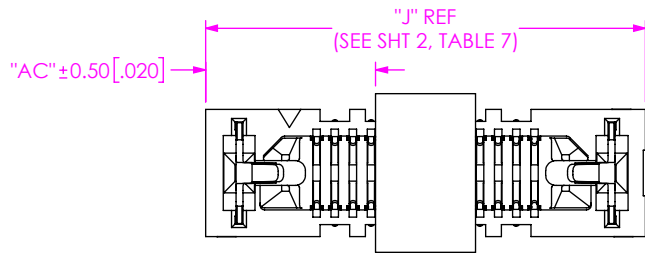

FIG 10
-P WITH -L OPTION
(ERM8-013-XX.X-XXX-DV-L-P SHOWN)
(SAME AS FIG 9, EXCEPT AS SHOWN)
(SOME CENTER FEATURES REMOVED FOR CLARITY)

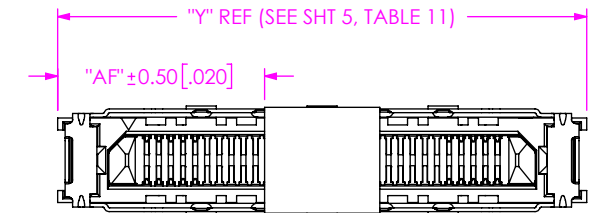

FIG 13
-P WITH -S OPTION
(ERM8-030-02.0-XXX-DV-S-P SHOWN)
(AVAILABLE ON -02.0 & -03.0 LEAD STYLES)
(SAME AS FIG 9, EXCEPT AS SHOWN)
(SOME CENTER FEATURES REMOVED FOR CLARITY)

TABLE 12

POSITION	PPP-XX	PAD WIDTH "Z"	NONE "AA"	-L "AC"	-EGP "AD"	-EGPS "AE"	-S	
							-05.0, -09.0 LEAD STYLE "AE"	-02.0, -03.0 LEAD STYLE "AF"
-005	PPP-88	4.40 [0.173]	2.80 [0.110]	4.30 [0.169]	4.30 [0.169]	N/A	N/A	N/A
-010		4.40 [0.173]	4.80 [0.189]	6.30 [0.248]	6.30 [0.248]	6.80 [0.268]	6.80 [0.268]	7.30 [0.287]
-011		4.40 [0.173]	5.20 [0.205]	6.70 [0.264]	6.70 [0.264]	N/A	N/A	N/A
-013		4.40 [0.173]	6.00 [0.236]	7.50 [0.295]	7.50 [0.295]	N/A	N/A	N/A
-020	PPP-87	7.62 [0.300]	7.19 [0.283]	8.69 [0.342]	8.69 [0.342]	9.19 [0.362]	9.19 [0.362]	9.69 [0.381]
-025		7.62 [0.300]	9.19 [0.362]	10.69 [0.421]	10.69 [0.421]	11.19 [0.441]	11.19 [0.441]	11.69 [0.460]
-030		7.62 [0.300]	11.19 [0.441]	12.69 [0.500]	12.69 [0.500]	13.19 [0.519]	13.19 [0.519]	13.69 [0.539]
-035		7.62 [0.300]	13.19 [0.519]	14.69 [0.578]	14.69 [0.578]	N/A	N/A	N/A
-040		7.62 [0.300]	15.19 [0.598]	16.69 [0.657]	16.69 [0.657]	N/A	N/A	N/A
-049		7.62 [0.300]	18.79 [0.740]	20.29 [0.799]	20.29 [0.799]	N/A	N/A	N/A
-050		7.62 [0.300]	19.19 [0.756]	20.69 [0.815]	20.69 [0.815]	N/A	N/A	N/A
-060		7.62 [0.300]	23.19 [0.913]	24.69 [0.972]	24.69 [0.972]	N/A	N/A	N/A
-070		7.62 [0.300]	27.19 [1.070]	28.69 [1.130]	28.69 [1.130]	N/A	N/A	N/A
-075		7.62 [0.300]	29.19 [1.149]	30.69 [1.208]	30.69 [1.208]	N/A	N/A	N/A
-100		7.62 [0.300]	N/A	N/A	N/A	N/A	N/A	N/A

PROPRIETARY NOTE
THIS DOCUMENT CONTAINS CONFIDENTIAL AND PROPRIETARY INFORMATION AND ALL DESIGN, MANUFACTURING, REPRODUCTION, USE, PATENT RIGHTS AND SALES RIGHTS ARE EXPRESSLY RESERVED BY SAMTEC, INC. THIS DOCUMENT SHALL NOT BE DISCLOSED, IN WHOLE OR PART, TO ANY UNAUTHORIZED PERSON OR ENTITY NOR REPRODUCED, TRANSFERRED OR INCORPORATED IN ANY OTHER PROJECT IN ANY MANNER WITHOUT THE EXPRESS WRITTEN CONSENT OF SAMTEC, INC.



520 PARK EAST BLVD, NEW ALBANY, IN 47150
PHONE: 812-944-6733 FAX: 812-948-5047
e-Mail info@SAMTEC.com code 55322

DO NOT SCALE DRAWING

SHEET SCALE: 5:1

DESCRIPTION:
0.8MM EDGE RATE TERMINAL ASSEMBLY

DWG. NO.
ERM8-XXX-XX.X-XXX-DV-XXXX-X-XX

BY: KNOWLDEN 9/27/2005 SHEET 6 OF 7

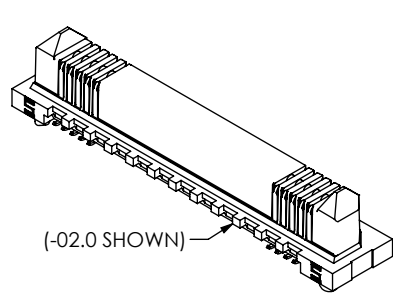

(-02.0 SHOWN)

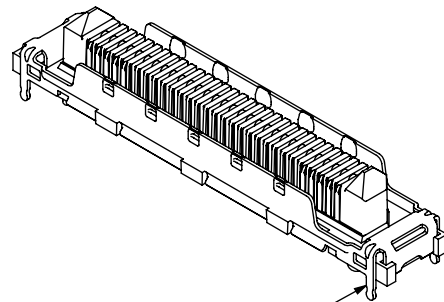

(-02.0 WITH -S OPTION SHOWN)

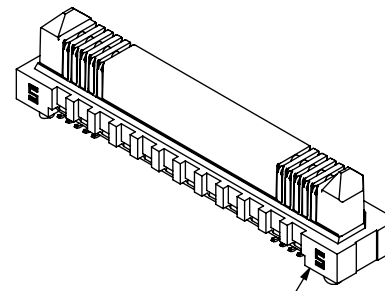

(-03.0 SHOWN)

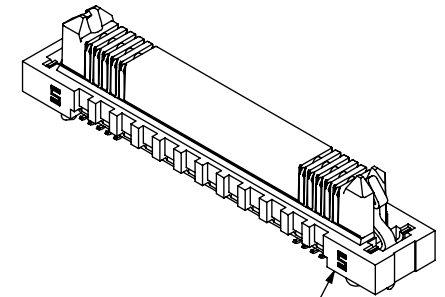

(-03.0 WITH -L OPTION SHOWN)

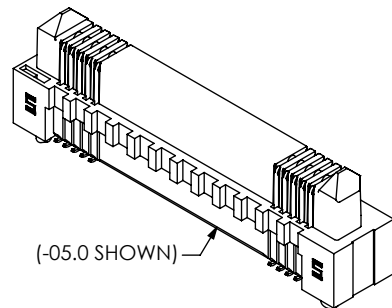

(-05.0 SHOWN)

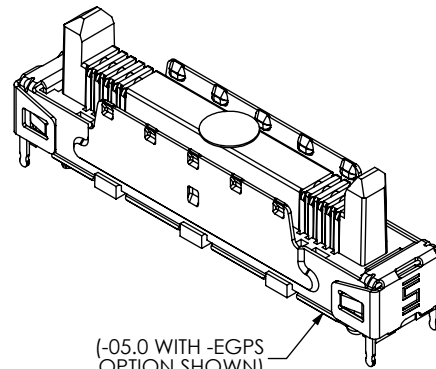

(-05.0 WITH -EGPS
OPTION SHOWN)

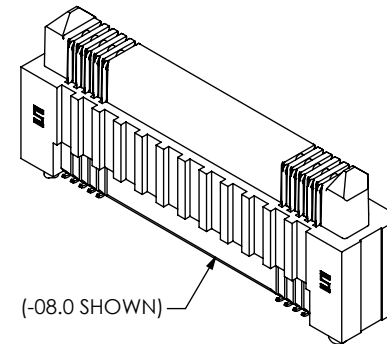

(-08.0 SHOWN)

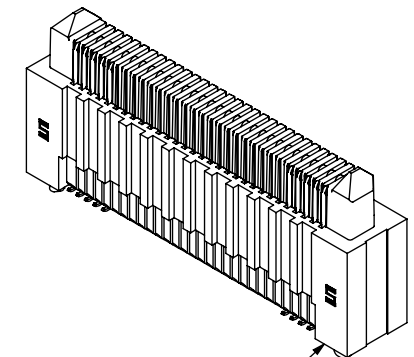

(-09.0 SHOWN)

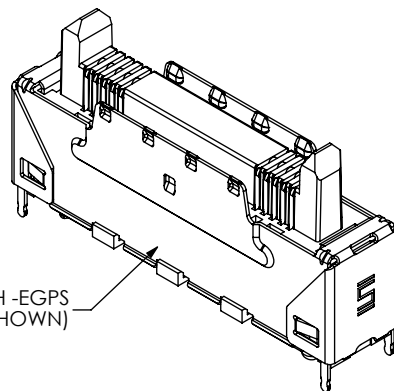

(-09.0 WITH -EGPS
OPTION SHOWN)

PROPRIETARY NOTE

THIS DOCUMENT CONTAINS CONFIDENTIAL AND PROPRIETARY INFORMATION AND ALL DESIGN, MANUFACTURING, REPRODUCTION, USE, PATENT RIGHTS AND SALES RIGHTS ARE EXPRESSLY RESERVED BY SAMTEC, INC. THIS DOCUMENT SHALL NOT BE DISCLOSED, IN WHOLE OR PART, TO ANY UNAUTHORIZED PERSON OR ENTITY NOR REPRODUCED, TRANSFERRED OR INCORPORATED IN ANY OTHER PROJECT IN ANY MANNER WITHOUT THE EXPRESS WRITTEN CONSENT OF SAMTEC, INC.

SHEET SCALE: 2:1



520 PARK EAST BLVD, NEW ALBANY, IN 47150
PHONE: 812-944-6733 FAX: 812-948-5047
e-Mail info@SAMTEC.com code 55322

DESCRIPTION:
0.8MM EDGE RATE TERMINAL ASSEMBLY

DWG. NO.
ERM8-XXX-XX.X-XXX-DV-XXXX-X-XX

BY: KNOWLDEN 9/27/2005 SHEET 7 OF 7