

IA611 SmartMic Always-On Voice Wake Audio Processor



The IA611 SmartMic is an “always-on” Audio Processor featuring Voice Wake and Voice ID keyword detector, a two-second buffer¹, and Knowles’ proven high performance acoustic SiSonic™ MEMS microphone technology in a single, miniature, top-port package. The IA611 offers flexibility by supporting the most relevant audio and data interfaces. Its integrated programmable DSP with 248 kBytes of RAM is available for customer and 3rd party algorithms, enabling unlimited creativity. The solution pushes the system performance to ultra-low power with its custom core design, and accelerates time to market with its highly integrated combination of hardware, software, and firmware.

Product Features

- High-accuracy Voice Wake and Voice ID keyword recognition to wake-up any system from a trigger phrase
- Minimum latency when burst out two-second audio buffer using SPI
- Ultra-low-power “always on” Acoustic Activity Detector (AAD) capable waking the embedded DSP
- Interrupt signal to the host processor when a voice keyword trigger is detected
- Integrated power tree from a single 1.8 V supply
- Extra flexibility with I²C/UART interfaces
- 248 kB RAM, 160 MFLOPS, 43 MHz, 32-bit complex-valued floating-point ALU, low-power open developer platform with SDK
- High-Performance Acoustic SiSonic MEMS with ± 1 dB matched sensitivity, 65.5 dB SNR and 132.5 dB SPL AOP
- Packaged in SPK 4.00 x 3.00 x 1.30 mm

Typical Applications

- Smartphones
- Wearables
- Tablets
- Headsets and true wireless earbuds
- Remote controls
- Connected home devices

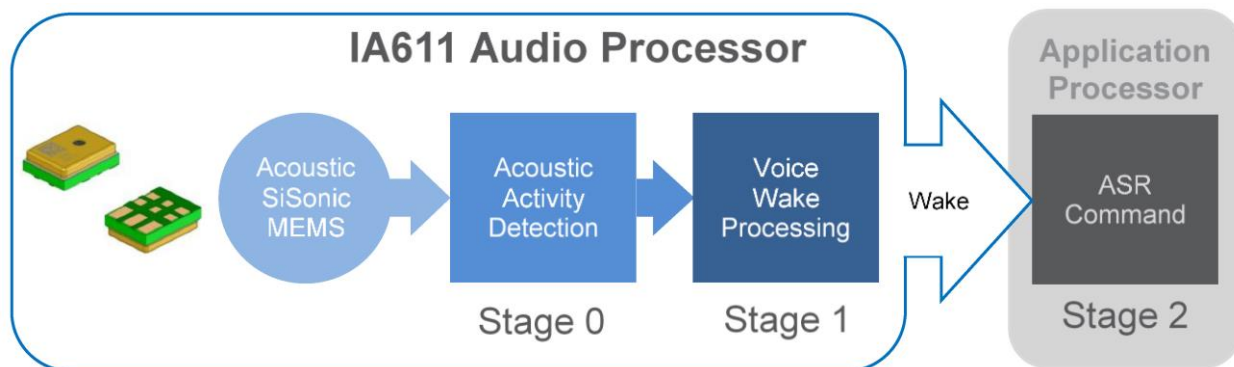

¹ Buffer size varies based on use-case and algorithm used.



Specification Summary

Absolute Maximum Ratings

Parameter	Absolute Maximum Ratings	Units
VDD to Ground	-0.3, +2.5	V
Digital Input to Ground	-0.3, VDD+0.3	V
Input Current (any pin)	±5	mA
Temperature	-40 to +100	°C

Stresses exceeding these Absolute Maximum Ratings can cause permanent damage to the device. These are stress ratings only. Functional operation at these or any other conditions beyond those indicated under SmartMic Specifications and Electrical Characteristics is not implied. Exposure beyond those indicated under SmartMic Specifications and Electrical Characteristics for extended periods can affect device reliability.

SmartMic Specifications

Test Conditions: VDD = 1.8V, No Load, at T_A = 25° C, 55±20% R.H., PDM+SPI mode, 3.072 MHz clock, unless otherwise specified.

Parameter	Symbol	Conditions	Min	Typ	Max	Units
Supply Voltage	VDD		1.71	1.8	1.98	V
Supply Current ¹	IDD	Deep-Sleep Mode	-	0.32	-	mA
		Voice Wake AAD Mode (stage 0)	-	0.40	-	
		Voice Wake Keyword Detect Mode (stage 1)	-	1.1 ²	-	
		Voice Wake Burst Mode (stage 2)	-	7.5	-	
		Hardware Pass-Through Mode	-	1.74	-	
		Hardware Pass-Through Mode (768 kHz Clock)	-	0.74	-	
Power Supply Rejection Ratio	PSRR	200 mVpp sinewave @1 kHz	-	87	-	dBV/FS
		200 mVpp sinewave @1 kHz (768 kHz Clock)	-	71	-	
Power Supply Rejection	PSR+N	200 mVpp 7/8 duty cycle rectangular waveform @ 217 Hz, A-weighted	-	-96	-	dBFS(A)
		200 mVpp 7/8 duty cycle rectangular waveform @ 217 Hz, A-weighted (768 kHz PDM clock)	-	-80	-	
Sensitivity ¹	S	94 dB SPL @ 1 kHz	-38	-37	-36	dBFS
		94 dB SPL @ 1 kHz (768 kHz PDM clock)	-22	-21	-20	
DC Output		Fullscale = ±100	-	0	-	% FS
Signal-to-Noise Ratio	SNR	94 dB SPL @ 1 kHz, A-weighted	-	66	-	dB(A)
		94 dB SPL @ 1 kHz, A-weighted (768 kHz PDM clock)	-	64.5	-	
Total Harmonic Distortion	THD	94 dB SPL @ 1 kHz, S = Typ	-	0.2	0.5	%
Acoustic Overload Point	AOP	1% THD @ 1 kHz, S = Typ	-	115	-	dB SPL
		10% THD @ 1 kHz, S = Typ	-	132.5	-	
Bandwidth	BW	-3dB relative to 1 kHz	-	50	-	kHz
Low-Frequency Roll-Off	LFRO	-3dB relative to 1 kHz	-	41	-	Hz
		-3dB relative to 1 kHz (768 kHz PDM clock)	-	95	-	
Directivity			Omnidirectional			
Polarity		Increasing sound pressure	Increasing density of 1's			
Functional Operating Temperature	T _A		-40	25	85	°C

¹ 100% tested.

² This is reference power consumption while running the Knowles VoiceQ engine. The power consumption may change based on the voice-detect engine.



Table of Contents

Chapter 1: Product Description	5
1.1 Overview	5
1.2 Key Features	5
1.3 AuViD Firmware Build Tool	6
1.4 Typical Application Block Diagrams	6
Chapter 2: Chip Description	7
2.1 DSP Subsystem	8
2.1.1 Hemi Delta Processor	8
2.1.2 Digital Filters	9
2.1.3 Audio Fabric	9
2.1.4 Memory	9
2.1.5 Audio Interfaces	10
2.1.6 Host Interfaces	12
2.2 System Control Unit	13
2.2.1 Boot Control	13
2.2.2 Reset Control	13
2.2.3 Power Management	13
2.3 Clock Control	14
2.3.1 PLL	14
2.3.2 Internal Oscillators	14
2.4 Interrupts	14
Chapter 3: Operating Modes	15
3.1 Bootloader Mode (SBL)	15
3.2 Voice Wake Mode	15
3.2.1 Intelligent Microphone Wake	16
3.2.2 Wake-up Trigger	16
3.3 Continuous Voice Wake	17
3.3.1 Keyword Preservation	18
3.4 OpenDSP	18
3.5 Software Pass-Through	18
3.6 Hardware Pass-Through	18
3.7 Deep Sleep Mode	18
3.8 Retention Sleep Mode	18
Chapter 4: Design Considerations	19
4.1 Latch On Reset Configuration Pins	19
4.2 Start-Up Sequencing	19
4.3 Sleep and Wake-up Sequence	20
4.4 State Diagram	21



Chapter 5: Pin Descriptions	22
5.1 Pinout Diagram.....	22
5.2 Pinout Table.....	22
Chapter 6: Electrical Characteristics	24
6.1 General Electrical Characteristics.....	24
6.2 PLL Characteristics	25
6.3 Oscillator Characteristics	25
6.4 Audio Port Interface Characteristics	26
6.4.1 I ² S/TDM Interface Slave Timing	26
6.4.2 I ² S/TDM Interface Master Timing.....	26
6.4.3 Audio Port PDM Interface Characteristics.....	27
6.5 I ² C Slave Interface Characteristics.....	27
6.6 SPI Interface Specifications	28
Chapter 7: PCB Design and Layout Guidelines	30
7.1 Power Planes.....	30
7.2 Digital Signal Routing	30
7.3 Typical Application.....	30
Chapter 8: Mechanical Specifications	31
8.1 Example Land Pattern	31
8.2 Example Solder Stencil Pattern	31
Chapter 9: Packaging and Marking Details.....	32
Chapter 10: Recommended Reflow Profile	33
Chapter 11: Additional Notes	34
Chapter 12: Materials Statement.....	35
Chapter 13: Reliability Specifications	36



Chapter 1: Product Description

1.1 Overview

The Knowles IA611 SmartMic is a flexible, low-power, and highly integrated voice and audio processor system for battery-powered applications. The IA611 includes:

- An advanced, Knowles audio-optimized DSP sub-system that:
 - runs compute-intensive audio processing algorithms with very low-power consumption, and
 - provides an efficient interface between custom software and the digital audio stream data.
- A System Control Unit (SCU) that handles booting, reset, and power management states such as deep-sleep mode, stage 0 and stage 1 Voice Wake activity.
- A flexible internal clock generation and routing system.
- Integrated interfaces for PDM and I²S/TDM digital audio data.
- A variety of control interfaces, including UART, SPI slave, or I²C slave. All have control interface and audio streaming capability.

The IA611 is optimized for low-power operation in a wide array of applications, including mobile devices.

The IA611 comes with a set of reference drivers for common operating systems and platforms; this makes for easy integration and fast time-to-market. The operating system software is written for the latest Android operating system and supports communication/data transport over the interfaces listed in Table 1.

Table 1 Android System Interfaces

Control Messages	Audio Ports	Audio Upload
I ² C	I ² S	I ² S
UART	I ² S	I ² S
SPI	PDM	SPI
UART	PDM	UART
I ² C	PDM	I ² C

Only one control interface can be used at a time. See section Chapter 5: for details.

1.2 Key Features

Key features of the IA611 processor include:

- Voice Wake
 - Ultra-low power.
 - Best-in-class.
 - Waits with DSP in sleep mode for acoustic activity before going into Voice Wake mode.
 - Always listening in keyword detection mode.
 - Ultra-low power acoustic activity detection mode.
 - Detection of either programmed (OEM) or user-trained keywords.
 - Continuous Voice Wake (CVQ) for seamless transition from Voice Wake to a command phrase that follows.
- SPI Slave interface for fast code download and control.



- OpenDSP custom Digital Signal Processing: Low-power operation, DSP clock rate up to 43 MHz, with 248 kB available RAM.
- Support pairing with an external PDM mic for dual-mic processing such as beamforming.

1.3 AuViD Firmware Build Tool

Knowles provides AuViD, a comprehensive tool for firmware development and testing, as well as IA611 system configuration.

AuViD 9.0.0 provides configuration, debug, and design capabilities for engineers. System capabilities include audio streaming, as well as system and route configuration. It can be used:

- offline sysconfig configuration and audio stream decoding,
- connected to the host directly for run-time debug using a host interface (I²C, UART, or SPI), or
- connected using an Android Proxy bridge.

1.4 Typical Application Block Diagrams

Figure 1 and Figure 2 show typical block diagrams for a host system using the IA611. (For pin configuration per boot mode, see Table 7 and Table 1.)

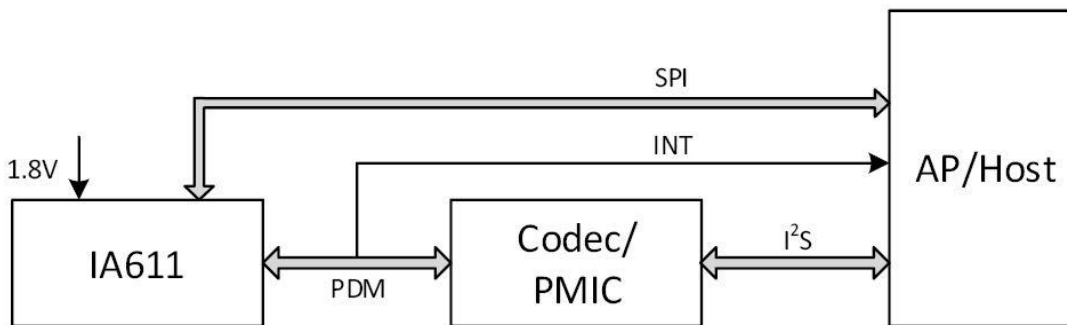

Figure 1 Application Schematic for a Host System using I2S with SPI

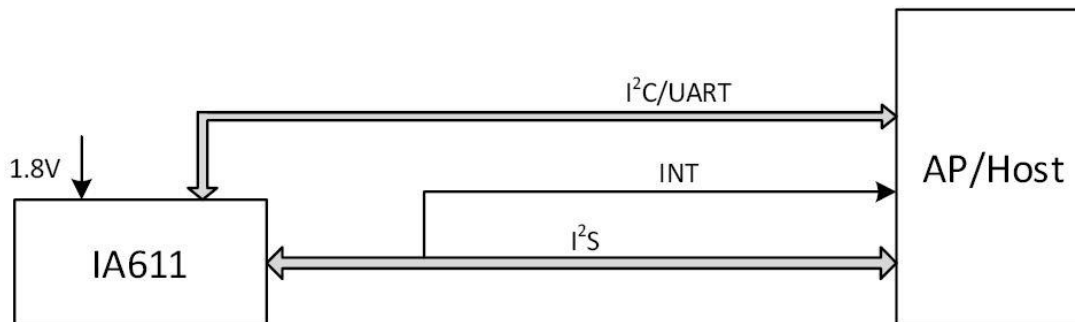

Figure 2 Application Schematic for a Host System using I2S and PC or UART



Chapter 2: Chip Description

Figure 3 shows the IA611's major modules, which are:

- Low-noise, dual-MEMS transducer microphone element.
- Ultra-low-power and high-performance DSP sub-system.
- Digital Audio Interface module that provides configurable serial digital audio ports, each supporting streaming a wide variety of data formats including PDM, I²S, or TDM.
- SPI, UART, and I²C Host Interfaces that include:
 - Communication with the host.
 - A channel for high-speed firmware downloads.
 - Audio data bursting for Voice Wake or diagnostic purposes.
- System Control Unit (SCU) that handles booting, reset, and power management states such as deep-sleep mode .
- Internal clock control module that generates internal clock signals and masters output clocks; it also locks internal time bases to externally-provided clocks.
- System interrupt module, which provides:
 - Interrupt to host for keyword detection events.
 - Event handling to IA611 for wakeup from host.



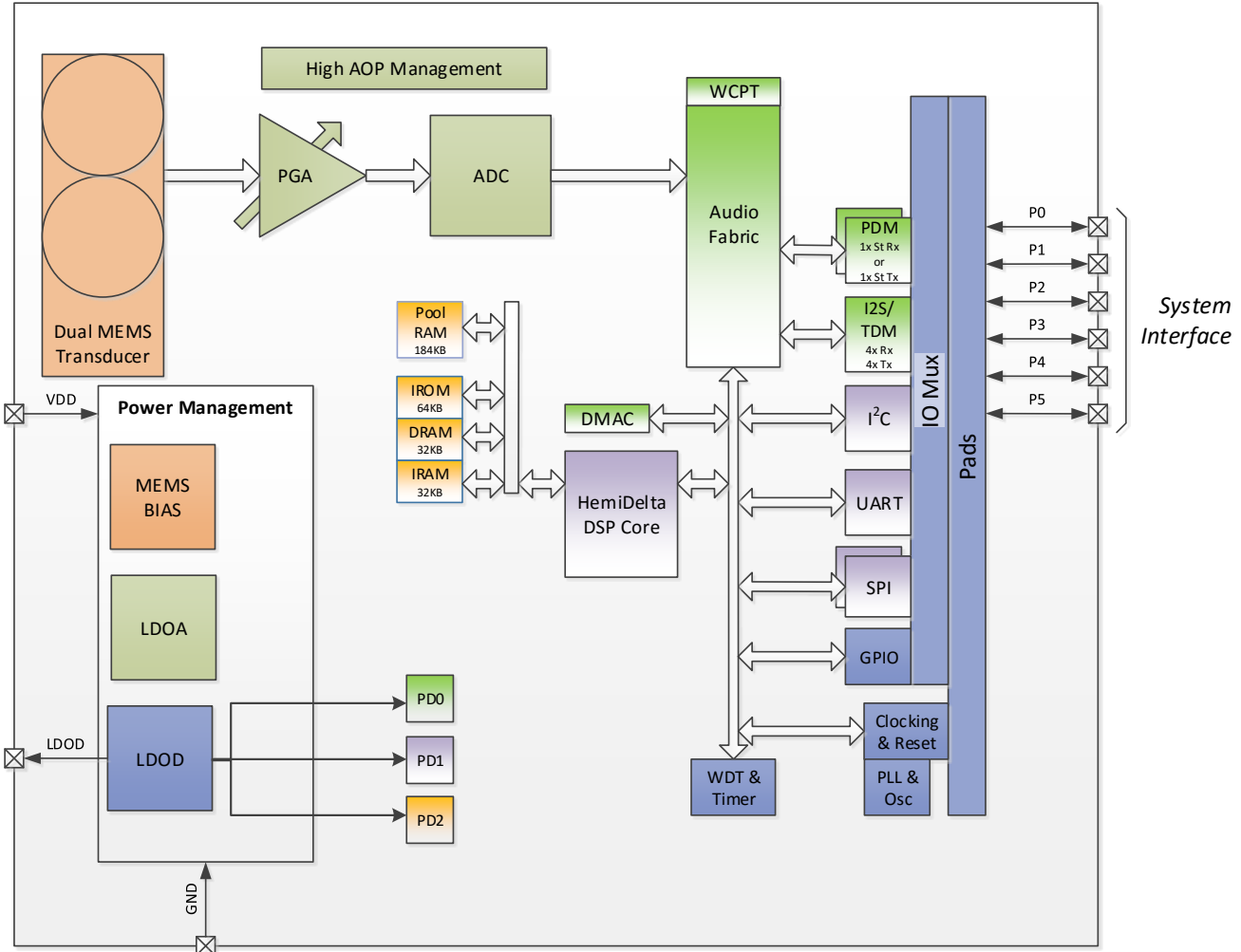

Figure 3 IA611 Block Diagram

2.1 DSP Subsystem

The DSP subsystem is comprised of a HemiDelta (HMD) processor, digital decimation and interpolation filters, the Audio Fabric, and memory.

2.1.1 Hemi Delta Processor

The HMD is a lower-power digital signal processor that is optimized for frame-based processing. Its features include:

- 64-bit instruction memory access (maximum instruction size: 64 bits).
- 64-bit data memory access (maximum register width: 64 bits).
- Main data type: 32-bit float (AFLOAT).
- Main vector register file: 16 vector registers (two 32-bit lanes each).
- Permutation registers to support load/store, permute, and arithmetic instructions.
- Dual issue instruction bundles.



- Vector and scalar instructions.
- Four MACs (real and complex arithmetic support).
- Nonlinear functions: arc tangent, cosine, sine, log, exponential, inverse, inverse square root, and sigmoid (exponential approximation).
- Added acceleration:
 - FFT
 - Peak finding
 - DNNs (eight 8-bit x 8-bit fixed-point MACs)

2.1.2 Digital Filters

The IA611 digital filters allow use of Pulse Density Modulation (PDM) audio data. There are four receive decimation filter chains, and two transmit interpolation filter chains. The decimation filters support one-bit PDM input oversampled audio data from digital microphones and codec interfaces. The interpolation filters generate one-bit PDM output oversampled audio data that can go to a speaker or codec.

2.1.3 Audio Fabric

The Audio Fabric is a memory mapped interface that allows any processor to access data efficiently from the various audio interfaces supported by the chip, such as I²S/TDM, or PDM. Each audio interface converts input data into a common 32-bit integer format; it is synchronized into the processor clock domain from the native audio clock before being multiplexed in the Audio Fabric into generic N-channel logical streams of audio data. Similarly, each audio interface can convert 32-bit integer format data into the encoding required for transmission. The audio fabric has support for a low-latency path; it also has connections to the wall clock/presentation timers unit to allow them to capture “timestamps” of audio data.

2.1.4 Memory

The IA611 has a total of 248 kB of RAM, divided as:

- 32 kB dedicated IRAM.
- 32 kB dedicated DRAM.
- 184 kB memory pool, consisting of five 32 kB blocks, one 16 kB block, and one 8 kB block.
- Of the total 248 kB memory, 168 kB is reserved for custom algorithm use.



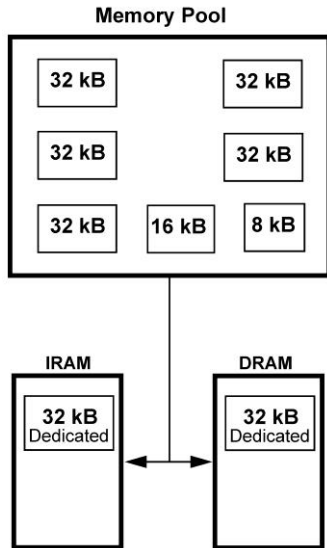

Figure 4 Memory Pool Structure

2.1.5 Audio Interfaces

The IA611 audio processor supports the following transfer of audio data:

- Master/Slave I²S/TDM.
- Two PDM output channels.

2.1.5.1 Digital Microphone PDM Output Interface

The IA611 has a single PDM output signal that can be used to transmit two audio channels. The data for one of the two audio channels is transmitted on each clock edge, as shown in Figure 5. In PDM output mode, the clock can be configured as input (slave) or output (master). If it is programmed as input, Table 2 lists the supported frequency ranges. If the clock is configured as output, the default output frequency is set to 3.072 MHz. For details, see the *IA61x API Guide* for flexibility on using PDM clock as an output.

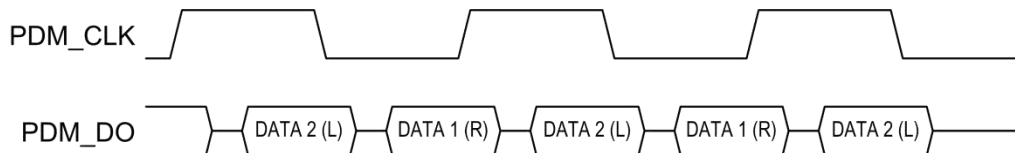

Figure 5 PDM Two-Channel Output Timing

Table 2 Supported PDM Clock Rates

PDM Clock (kHz)	Recommended Max Bandwidth of Audio Signal (kHz)
512	8
768	8
1024	10.66
1536	16
2048	21.33
2400	25
3072	32
4608	48
4800	50



2.1.5.2 I²S/TDM Digital Audio Port

When in I²S+ I²C or I²S+UART mode, the IA611 can transfer audio data using the I²S or TDM protocol with an external host or codec device. (Table 7 on page 23, and Table 1, list the pin configuration in these modes.) Using API commands, the IA611 can be configured to operate either in slave or master mode.

I²S transfers have the following features.

- Bit clock (I2S_CLK) up to 24.576 MHz.
- Sampling clock (I2S_WS) up to 192 kHz.
- There must be exactly two slots, Left (I2S_WS low) and Right (I2S_WS high).
- There must be an equal number of I2S_CLK periods in each half I2S_WS period.
- Support for 8 to 32 audio data bits per slot (channel).

Figure 6 shows an example of I²S mode.

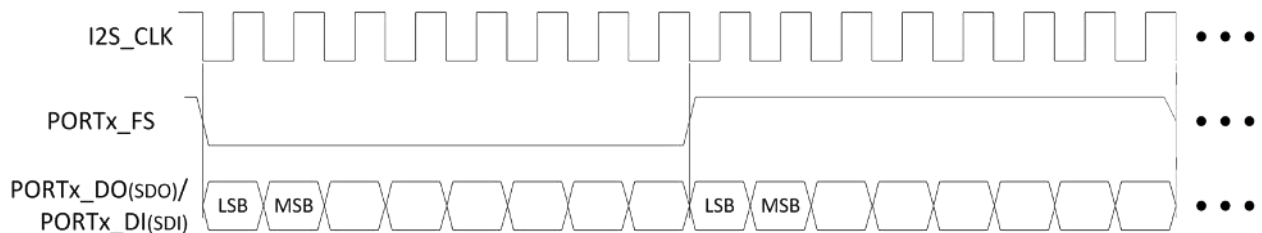

Figure 6 I²S Mode

TDM transfers have the following features:

- Bit clock (I2S_CLK) up to 24.576 MHz.
- Sampling rates of up to 192 kHz.
- Frame Sync pulse (I2S_WS) must be at least one bit clock wide.
- Support for up to four active slots (channels) out of 32. Slots do not need to be contiguous. In master mode, the master clock generator supports up to 256 clocks per frame, but slave TDM operation is not limited by clocks per frame, and supports up to 32 slots with 32 data bits per slot.
- Support for 8 to 32 audio data bits per slot (channel).
- Support for output transmission on either rising or falling bit clock edge.
- Support for input sampling on either rising or falling bit clock edge.
- Transmitting and sampling edges must be of opposite polarity.
- Support for both MSb-first and LSb-first transmission modes.



Figure 7 shows an example of TDM mode.

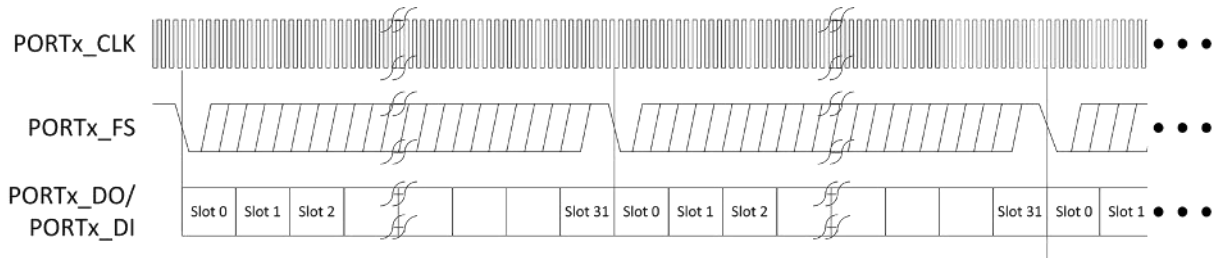

Figure 7 TDM Mode

2.1.6 Host Interfaces

2.1.6.1 Firmware download, Command and Control

The IA611 audio processor supports command and control over the following interfaces.

- SPI up to 13 Mbps.
- UART up to 2.048 MBaud.
- I²C up to 1 MHz.

2.1.6.2 SPI

The IA611 supports a four-wire Serial Peripheral Interface (SPI) protocol up to 13 Mbps. The SPI slave port can be used to download a firmware image onto the IA611 and to send API control and data to the IA611.

2.1.6.3 UART

The IA611 supports a two-wire UART (UART_TX, UART_RX). The UART can be used to download a firmware image onto the IA611, and a UART connection to the host is required for streaming as alternative to ID tapping. The interface can detect the baud rate automatically up to 115 kHz; it also supports baud rates of 0.4608, 0.9216, 1.000, 1.024, 1.152, 2.000, and 2.048 MHz as configured by the host using the Bootloader UART baud rate change API command, or by the firmware after the binary file has been downloaded.

2.1.6.4 I²C

The IA611 supports a Slave I²C bus as the host interface with a 7-bit address range. The I²C address can be set through the data output Latch On Reset (LOR) configuration pin, as described in Section 4.1. The I²C interface can be used to download a firmware image onto the IA611.

2.1.6.5 Debug

The collection of diagnostic data streams is supported on the SPI, UART, and I²C interfaces. This requires the ability to collect synchronized input/output streams using any of the interfaces.

Debug is supported either by a virtual connection over ADB to an Android Proxy running on the host processor, or by a direct physical connection to test-points on the system PCB, with no-load resistors connected to the SPI, UART, I²C I/O pins for the IA611.



2.2 System Control Unit

2.2.1 Boot Control

Upon the supply of power to VDD pin, the IA611 goes through a power-up initialization process. During this, the IA611 does not respond to host requests. The IA611 then enters an auto-detect mode for control interfaces to determine which pin configuration to use for operation. See Section 4.2 for more information on the start-up sequence; see the *IA61x API Guide* for more information on the auto-detect sequence.

2.2.2 Reset Control

The IA611 has no external reset pin; it generates an internal reset signal on initial power-up, after receipt of a reset command from the host, or on detection of any communication issues through the use of an on-board watchdog timer. The IA611 has a variety of low-power modes it can enter and exit without requiring a reboot and re-download of system firmware (see section Chapter 3: on page 15). Thus, it is recommended that the IA611 supply voltage be left on all of the time.

2.2.3 Power Management

The block diagram in Figure 3 color codes the different power domains of the IA611. There are three primary power domains: one to supply the bias of the MEMS element, one to supply the core analog signal path circuitry, and one to supply the core DSP subsystem. The DSP core subsystem has three subordinate power domains that can be independently controlled to optimize power in various use cases. This section provides further details around the primary ASIC power domains.

Table 3 Power Supply Pins

Name	Voltage	Max Current	Power Direction	Comment
GND	0 V	25mA	-	
VDD	1.8V	25mA	Input	Main microphone IO supply.
LDOD	0.6V to 1.2V	23mA	Output	Primary supply for DSP functions of the microphone.

where:

GND — This is the common ground pin for all IA611.

VDD — This supply provides power to all I/Os, as well as the power management blocks (LDOs) in the microphone.

LDOD — This provides the power output for the DSP subsystem, including the processor, memory, Audio Fabric, and core logic. The output can range from 0.6 V to 1.2 V.



2.3 Clock Control

2.3.1 PLL

The IA611 has an integrated, high-performance Phase Lock Loop (PLL) that provides clocks for the processors, memory, and related circuits; it also provides oversampling clocks that drive the serial control communications interfaces. See Table 9 for performance details of the PLL.

2.3.2 Internal Oscillators

The IA611 has two integrated silicon oscillators: one optimized for low-power, the other optimized for accuracy and system flexibility.

2.3.2.1 Low-Power Oscillator

The low-power oscillator is calibrated at the factory, and the output frequency is always set to 768 kHz. This oscillator is specifically designed for low-power voice-wake modes.

2.3.2.2 High-Performance Oscillator

The high-performance oscillator is also calibrated at the factory, and the output frequency is set to 43 MHz. This output frequency can be divided down by counters within the IA611 for use by various internal modules, or for use as a master output clock. See section 6.3, on page 25, for performance details of this oscillator.

2.4 Interrupts

The IA611 provides an interrupt request to the host for a keyword detection event through the `HOST_IRQ` function, as well as a wakeup event from the host through the `WAKE` function.

The `HOST_IRQ` and `WAKE` function maps to a particular pin based on the configuration; see Table 7 on page 23, and Table 1, as well as the *IA61x API Guide* for more information.



Chapter 3: Operating Modes

The IA611 can be in one of the following operating modes:

- Bootloader Auto-Detect Mode — After power up, the IA611 detects the host control interface and waits for firmware download.
- Voice Wake Mode — The IA611 is in low-power mode and can detect spoken keywords.
- Software Pass-Through Mode — The IA611 acts as a left- or right-channel PDM or I²S microphone data to the host.
- Hardware Pass-Through Mode — The IA611 acts as a duplicated PDM signal to the host.
- Deep-Sleep Mode — This is the low-power mode when the IA611 is not in use.
- Retention Sleep Mode — The IA611 is in very low-power mode, where memory is retained.

3.1 Bootloader Mode (SBL)

Upon system power-up, or after deep-sleep mode, the IA611 is in Bootloader Mode and waits for either an API command to determine the host control interface, or a PDM clock to enter HW Bypass Mode. Once the control interface is determined, firmware can be downloaded and the IA611 can be configured to put the IA611 into one of the other listed modes. See the *IA61x API Guide* for details on auto-detecting the control interface, firmware download, and mode switching.

3.2 Voice Wake Mode

The Voice Wake feature on the IA611 processor provides low-power voice wake-up based on detection of either a built-in keyword (OEM keyword) or a user-trained OEM keyword (Voice ID). The host can go into a very-low-power mode and wait for the IA611 to sense activity and wake it up.

In Voice Wake mode, the IA611 monitors the microphone stream for acoustic activity in an ultra-low-power mode. When acoustic activity is detected, the IA611 automatically enters into a slightly higher power mode to analyze the speech utterance for the presence of the wake-up keyword. When a valid keyword is detected, the IA611 asserts an interrupt to the host processor to trigger complete system wake-up. If a keyword is not detected, the device returns to the ultra-low power mode until acoustic activity is detected again. The timeline for this is shown in Figure 8.

Due to its ultra-low-power, Voice Wake enables an always-on touchless user interface for mobile device or IoT wake-up.



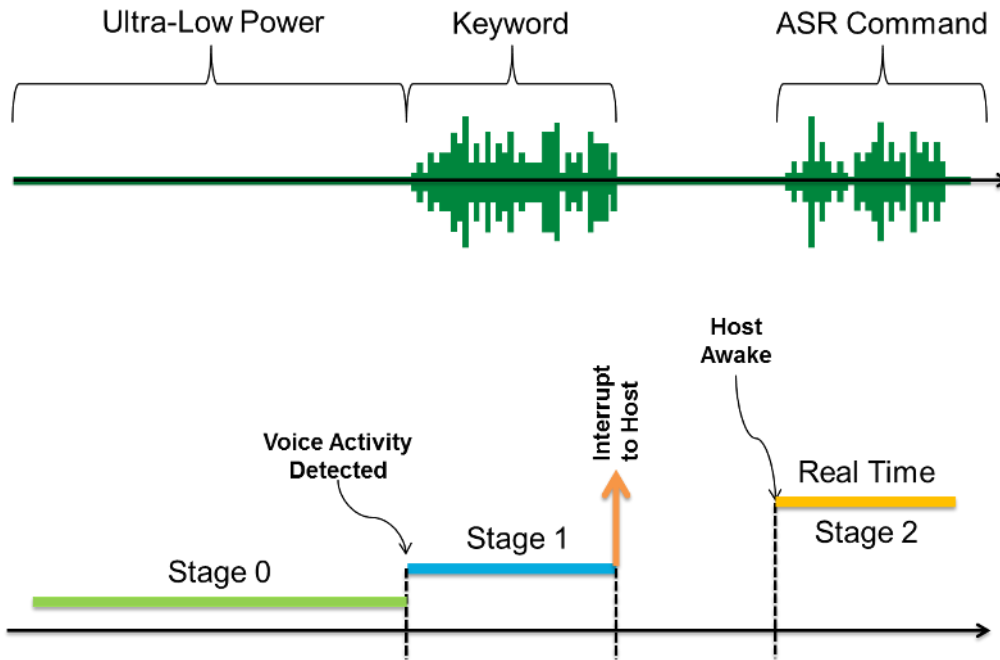

Figure 8 Timeline in Voice Wake Mode

3.2.1 Intelligent Microphone Wake

In the Sleep state, the IA611 wakes up when a falling edge (high-to-low) is detected on the Wake input pin. From the sleep state, the IA611 also wakes up due to acoustic activity and transitions to keyword detection mode. After the keyword is detected, the IA611 can transition to Command mode or start real-time data streaming.

3.2.2 Wake-up Trigger

Voice Wake keeps the mobile device in a low-power, always-on listening mode, in which the device is listening for the wake-up trigger. Once the trigger is detected, the device wakes up and performs the desired action. Voice Wake offers the choice of OEM-selectable, user-selectable, or user-dependent OEM wake-up triggers.

3.2.2.1 OEM Selectable Wake-up Triggers

With this option, OEMs can select a keyword to wake the device. This wake-up trigger wakes up the mobile device whenever the user says this word. This OEM-selectable trigger is speaker-independent and does not require user training.

3.2.2.2 User Dependent OEM Wake-up Triggers

With this option, users can train their device to only wake up to their voice when speaking the OEM keyword. In this mode, the user trains the system by speaking the OEM key phrase several times in a relatively quiet environment. The OEM-selectable trigger then is speaker-dependent, which means that once a user has trained the system to his or her voice, the system recognizes and responds only to that voice.



3.3 Continuous Voice Wake

The Continuous Voice Wake feature starts where the Voice Wake feature leaves off, and buffers up to two seconds of speech on-chip after receiving the wake-up trigger. It then passes this speech (and optionally also the keyword) to the automated speech recognition (ASR) engine running on the host processor. Continuous Voice Wake allows devices to continuously listen to their surroundings, wake up upon a simple, configurable voice keyphrase, and then act on the instructions that follow.

For example: Hello Voice Q, what is the weather like today?

The IA611 is part of a larger system that includes the Codec, Host Application Processor, and Baseband processor, along with peripheral control busses such as UART that connect them. Continuous Voice Wake is performed by the system as a whole in the following stages.

Stage 0 (AAD Mode): The IA611 is in ultra-low power mode. The main processor is turned off. The IA611 detects surrounding sound and only goes to State 1 when the acoustic level exceeds the internal threshold.

Stage 1 (Keyword Detect Mode): The IA611 is in low-power mode and processing inbound microphone samples for the presence of one of the pre-loaded keywords. When a keyword is detected, the IA611 generates an interrupt to the Host, then saves some relevant state information. The IA611 then transitions to stage 2.

Stage 2 (Burst Mode): While the host is waking up, the IA611 continues buffering mic data in a two-second circular audio buffer. Once the host is running, it can start bursting the audio buffer over SPI/UART/I²S/I²C. Once the host decides to stop the capture, it can put the IA611 back into stage 0 (Voice Wake Mode) or Pass-Through Mode. Figure 9 shows this timeline.

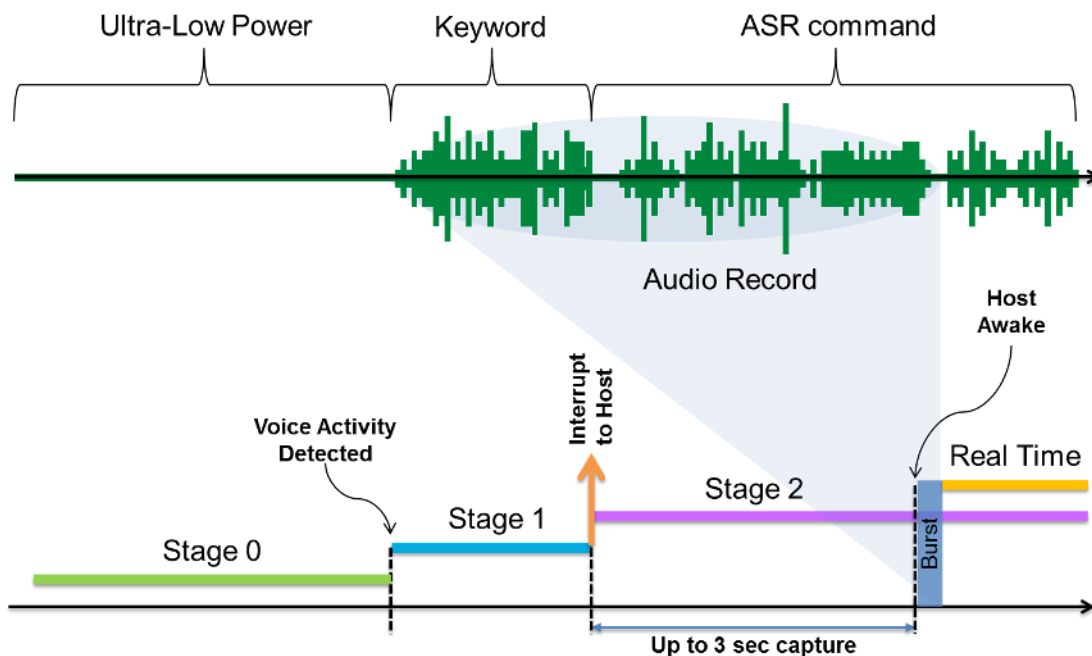

Figure 9 Continuous Voice Wake System Timeline



3.3.1 Keyword Preservation

Continuous Voice Wake can be configured to maintain the 16 kHz keyword and pass it to the host with the buffer. This allows for secondary host-based inspection of the keyword as well as ASR channel estimation. Due to the memory needed to keep the keyword, enabling this feature limits the number of available keywords.

3.4 OpenDSP

248 kBytes of RAM enables third-party algorithms, with dynamic audio filtering and keyword detection as examples. Knowles provides a Software Development Kit to enable third-party developers to create DSP algorithms on the IA611 Audio Processor platform.

Contact Knowles for access to the SDK and associated Developer's Guide.

3.5 Software Pass-Through

The IA611 can be in software pass-through mode, in which case it acts as a left- or right-channel PDM or I²S microphone audio to the host. Software Pass-Through mode is supported only after firmware download.

3.6 Hardware Pass-Through

Hardware Pass-Through allows the host to put the IA611 in a low-power digital audio pass-through mode to bypass processing. In this mode, the IA611 acts as a dual-mono PDM microphone.

3.7 Deep Sleep Mode

Deep Sleep mode can be entered after firmware has been downloaded. When the chip enters into sleep mode, the memory content is not retained. A wakeup signal from deep sleep is required to bring the chip into boot loader (SBL) mode. A firmware download may be needed after the wakeup from deep sleep mode. Exiting deep sleep requires all internal hardware blocks to restart. This is the lowest power mode of the IA61x.

3.8 Retention Sleep Mode

Retention Sleep mode can be entered after firmware has been downloaded. The chip enters into normal sleep mode, and the memory content is retained. A wakeup signal from retention sleep mode is required to bring the chip into firmware mode. A firmware download is not needed after the wakeup from retention sleep mode. Exiting retention sleep restarts all internal hardware blocks that were powered off due to the sleep command.



Chapter 4: Design Considerations

4.1 Latch On Reset Configuration Pins

The IA611 contains two Latch On Reset (LOR) address pins that set the I²C slave address when in I²C mode. The state of the address pins is latched when power is on and stable. An internal pull-down resistor pulls the address pins low (0) when unconnected. To set the address pin to a logical value of 1, connect the LOR pin to the same power supply that powers the IA611 with an external 10 kΩ pull-up resistor.

Table 4 shows the configuration of the address pins and the resulting I²C address.

Table 4 Latch On Reset Configuration for I²C Address

ADDR1	ADDR2	Description
0	0	7 bit, address 0x3E (default)
0	1	7 bit, address 0x38
1	0	7 bit, address 0x3F
1	1	7 bit, address 0x39

4.2 Start-Up Sequencing

Figure 10 shows a complete start-up sequence, including system power and the host bus.

After Latch On Reset, the IA611 wakes up in the Auto-detect state, in which it determines the control interface and waits for command communication or firmware download from the host.

Note that the host interface pins must be floating or driven to ground during VDD power up so that they are never at a higher voltage than VDD+0.3 V.

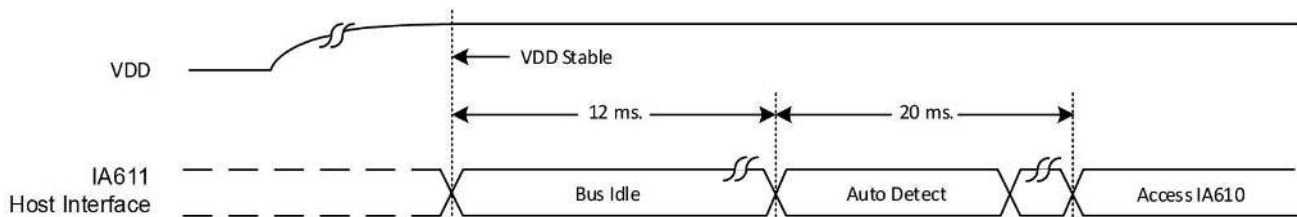

Figure 10 Start-up Sequence

The host must follow a defined sequence to download program code into the IA611. The *IA61x API Guide* provides a detailed description of program code download sequences over the various interfaces.



4.3 Sleep and Wake-up Sequence

The IA611 can be placed into an ultra-low-power sleep state to minimize power consumption. During sleep, the host can continue to access other devices connected to the host interface buses.

Figure 11, Figure 12, and Table 5 provide a general overview of the sleep and wake-up process and their timings. The *IA61x API Guide* provides a detailed description of the sleep and wake-up sequences.

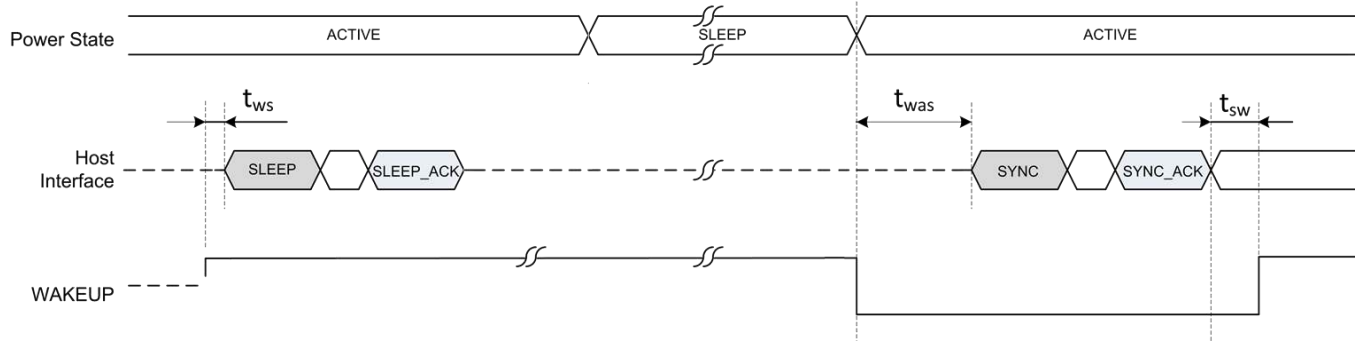

Figure 11 Sleep and Wake-Up Sequence for Waking Up the IA611 Using the WAKEUP Input

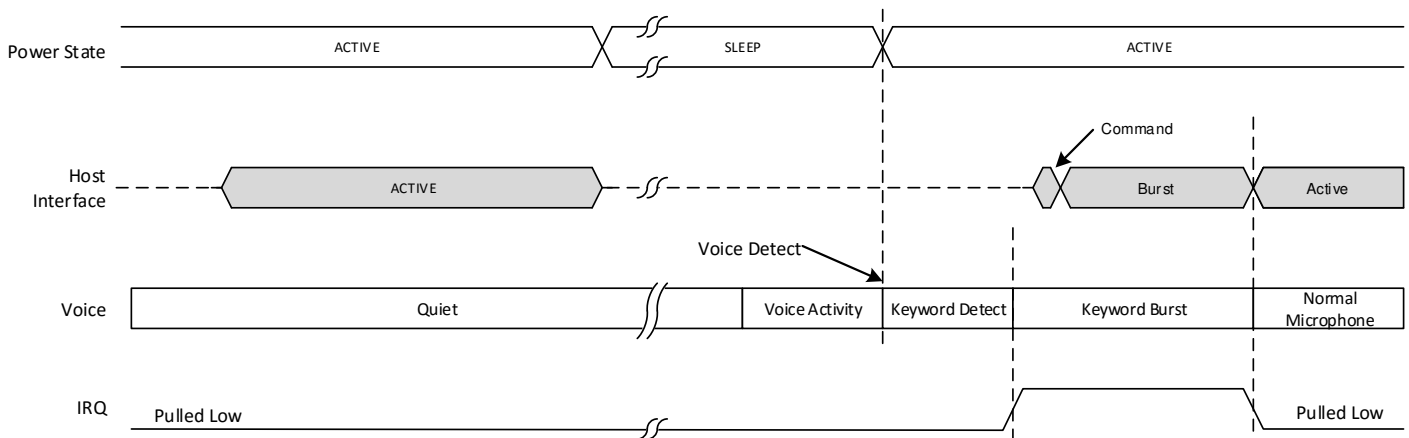

Figure 12 Sleep and Wake-up Sequence for Voice Wake mode

Table 5 Sleep and Wake-up Sequence Timings

Parameter	Symbol	Min	Typ	Max	Units
Time from WAKEUP deasserted to SLEEP command write	t_{ws}	30	-	-	ms
Time from WAKEUP asserted to SYNC command write	t_{was}	30	-	-	ms
Time from SYNC_ACK read to WAKEUP deasserted	t_{sw}	0	-	-	ms



4.4 State Diagram

The IA611 state diagram is shown in Figure 13.

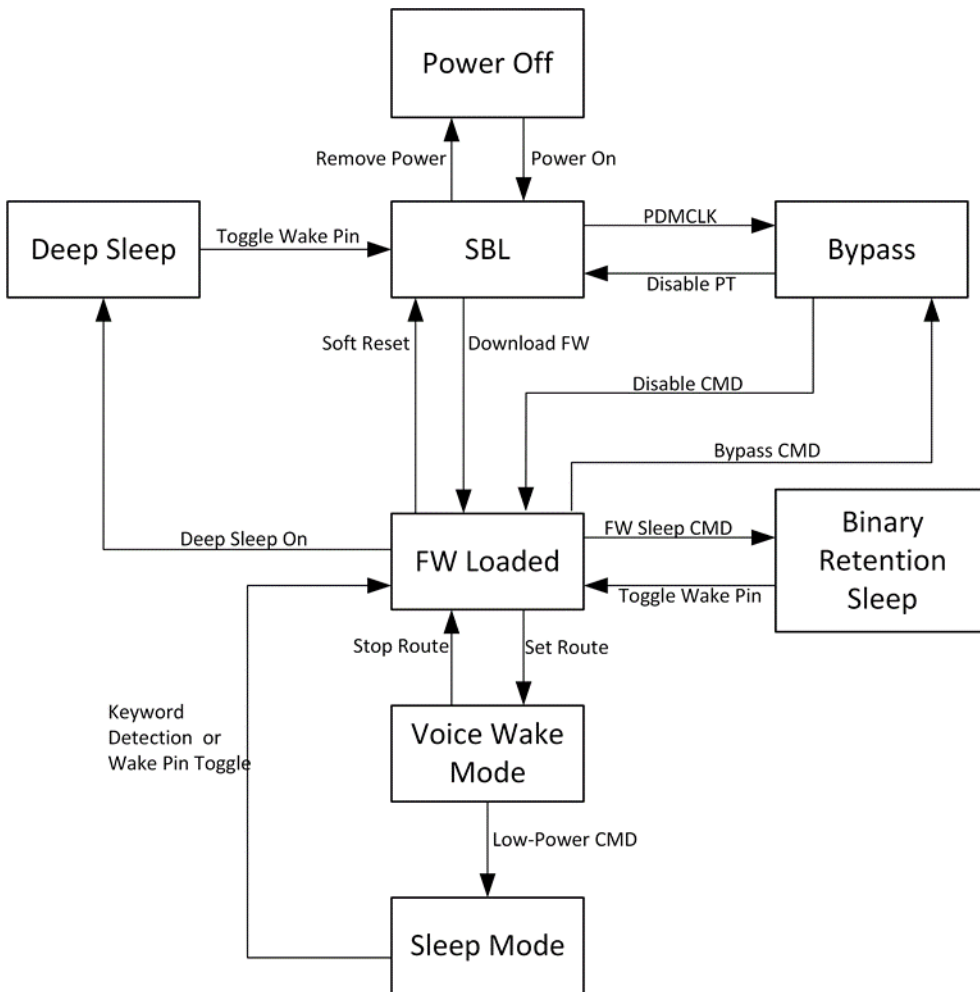

Figure 13 IA610 State Diagram



Chapter 5: Pin Descriptions

5.1 Pinout Diagram

Figure 14 shows the pinouts for the IA611 (bottom view).

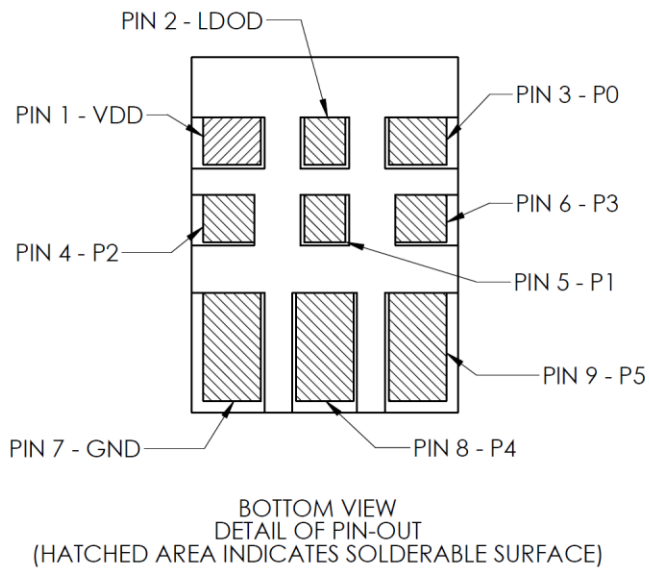

Figure 14 Pin Assignments (Bottom View)

5.2 Pinout Table

Table 6 shows a list of the IA611 pins and the signals associated with them. In active mode, the pin state is set by firmware and differs from mode to mode. Firmware can configure a pin as an input or an output; it also can enable internal pull-ups or pull-downs, if available.

Table 6 Pin Descriptions

Pin#	Name	Type	Description
1	VDD	Power	Power Supply
2	LDOD	Power	Connect to Bypass Capacitor
3	P0	Digital I/O	P0 I/O
4	P2	Digital I/O	P2 I/O
5	P1	Digital I/O	P1 I/O
6	P3	Digital I/O	P3 I/O
7	GND	Power	Ground
8	P4	Digital I/O	P4 I/O
9	P5	Digital I/O	P5 I/O



Table 7 Pin Configuration Per Boot Mode

Mode	P0	P1	P2	P3	P4	P5	IRQ	WAKE
PDM + I ² C	PDM_CLK	PDM_SDO	I2C_ADDR1 WAKE	I2C_ADDR2 IRQ	I2C_SCLK	I2C_SDA	P3	P2
PDM + UART	PDM_CLK	PDM_SDO	NA	IRQ	UART_RX WAKE	UART_TX	P3	P4
PDM + SPI	PDM_CLK	PDM_SDO IRQ	SPI_SCLK	SPI_MISO	SPI_SS WAKE	SPI_MOSI	P1	P4
I ² S + I ² C	I2S_WS	I2S_CLK	I2S_SDI I2C_ADDR1 WAKE	I2S_SDO I2C_ADDR2 IRQ	I2C_SCLK	I2C_SDA	P3	P2
I ² S + UART	I2S_WS	I2S_CLK	I2S_SDI	I2S_SDO IRQ*	UART_RX WAKE	UART_TX IRQ*	P3	P4

*IRQ can be configured to be on either I2S_SDO or UART_TX, depending on the configuration settings.



Chapter 6: Electrical Characteristics

6.1 General Electrical Characteristics

Table 8 *Electrical Characteristics*

Test conditions: $V_{DD} = 1.8V$ at $T_A = 25^\circ C$, unless otherwise specified.

Parameter	Symbol	Min	Typ	Max	Units
Digital Input High-Level Voltage	V_{IH}	$0.65 \cdot V_{IO}$			V
Digital Input Low-Level Voltage	V_{IL}	-0.2		$0.35 \cdot V_{IO}$	V
Digital Output High-Level Voltage	V_{OH}	$0.65 \cdot V_{IO}$			V
Digital Output Low-Level Voltage	V_{OL}			$0.35 \cdot V_{IO}$	V
Programmable Digital Input Internal Pull-Down Resistor		35	61	114	k Ω
Programmable Digital Input Internal Pull-Up Resistor		39	71	138	k Ω
I/O drive strength (default)		7	12	17.5	mA
Capacitance To Ground of I/O Pins	C	9		18	pF

Note: Maximum output current source or sink drive by any I/O pin is programmable in four steps. The default is 4 mA nominal. See the *IA61x API Guide* for details and settings.

Note: External I/O loading and drive strength have a direct effect on voltage V_{IH} and V_{IL} transition times. For timing critical signals, the values of any external R and C components connected to the I/O pins must be adjusted based on the application.



6.2 PLL Characteristics

Table 9 lists the PLL operation parameters. The PLL has two frequency ranges of operation, set through the software API. PFD refers to the Phase-Frequency Detector on the PLL, which receives a divided-down version of the reference clock.

Table 9 PLL Characteristics

Test conditions: VDD = 1.8V at T_A = 25° C, unless otherwise specified.

Parameter	Symbol	Conditions	Min	Typical	Max	Units
Reference Frequency	f _{PLL_IN}		0.768		200	MHz
PFD Frequency	f _{PLL_PFD}	Low Range	0.768		f _{PLL_VCO} ÷ 4	MHz
		High Range	0.768		f _{PLL_VCO} ÷ 8	MHz
VCO Frequency	f _{PLL_VCO}	Low Range	28		140	MHz
		High Range	120		600	MHz
Output Frequency	f _{PLL_OUT}		0.11		600	MHz
Lock Time	t _{PLL_LOCK}		500		1000	PFD cycles
Feedback Divider	N _{PLL_FBDIV}		4		781	integer
Loop Bandwidth	f _{PLL_BW}			f _{PLL_PFD} /25		MHz
Period Jitter (random)	t _{PLL_JIT_RND}	f _{PLL_VCO} = 50 MHz		$0.7 \text{ pS} \times \sqrt{\frac{600 \text{ MHz}}{f_{PLL_VCO}}} \times \sqrt{\frac{600 \text{ MHz}}{f_{PLL_OUT}}}$	8.4	pS (RMS)
Period Jitter Power Supply Noise Sensitivity	t _{PLL_JIT_PS}			1.5		pS/mV
Period Jitter from reference spur	t _{PLL_JIT_REF}			1%		Output clock cycle
Integrated Long-Term Jitter	t _{PLL_JIT_LT}	Measured on output from 20 kHz to 6.144 MHz. f _{PLL_PFD} =12.288 MHz, f _{PLL_VCO} =125 MHz		$110 \text{ pS} \times \sqrt{\frac{6 \text{ MHz}}{f_{PLL_PFD}}} \times \sqrt{\frac{128 \text{ MHz}}{f_{PLL_VCO}}}$	78	pS (RMS)

6.3 Oscillator Characteristics

The on-chip silicon oscillator is calibrated in the factory and has the characteristics listed in Table 10. There are two ranges of operation, set by internal register through the software API.

Table 10 Oscillator Characteristics

Test conditions: VDD = 1.8V at T_A = 25° C, unless otherwise specified.

Parameter	Symbol	Conditions	Min	Typical	Max	Units
Output Frequency	f _{OSC_OUT}	Low Range		43.008		MHz
		High Range		172.032		MHz
Output Frequency Temperature Dependence	Δ _{OSC_T}	0 to 80°C		340	535	ppm/°C
Period Jitter (random)	t _{OSC_JIT_RND}	Low Range			44	pS (RMS)
		High Range			22	
Period Jitter Power Supply Noise Sensitivity	t _{OSC_JIT_PS}	Low Range		0.9	2.2	pS/mV



6.4 Audio Port Interface Characteristics

6.4.1 I²S/TDM Interface Slave Timing

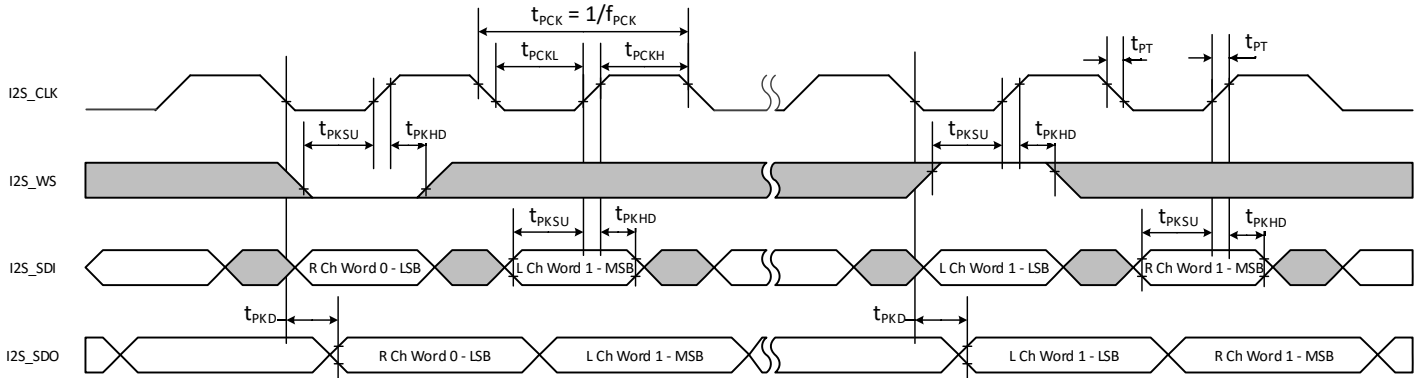

Figure 15 I²S/TDM Interface Slave Timing

In Slave Mode, I2S_CLK and I2S_WS are inputs.

Table 11 I²S/TDM Slave Timing

Test Conditions: VDD = 1.8V, 10pF Load, at T_A = 25° C, unless otherwise specified. Measurement levels on waveforms are V_{ih} and V_{il}. ^{Note 1}

Parameter	Symbol	Min	Typ	Max	Units
I2S_CLK Clock Frequency	f _{PCK}			24.576	MHz
I2S_CLK Clock Cycle Time	t _{PCK}		1/f _{PCK}		s
I2S_CLK Clock High Pulse Width	t _{PCKH}	35			% t _{PCK}
I2S_CLK Clock Low Pulse Width	t _{PCKL}	35			% t _{PCK}
I ² S input transition time	t _{PT}		10		ns
I2S_SDI and I2S_WS Input Setup Time to CLK ^{Note 2}	t _{PKSU}	25			ns
I2S_SDI and I2S_WS Input Hold Time from CLK ^{Note 2}	t _{PKHD}	5.1			ns
I2S_SDO Data Output Delay from CLK ^{Note 3}	t _{PKD}	0		15	ns

Note 1: Timing parameters are guaranteed by design; they are not tested in the final test.

Note 2: The I2S_WS and I2S_SDI inputs are set to be sampled at the rising edge of the I2S_CLK.

Note 3: The I2S_SDO outputs are set to drive at the falling edge of the I2S_CLK.

6.4.2 I²S/TDM Interface Master Timing

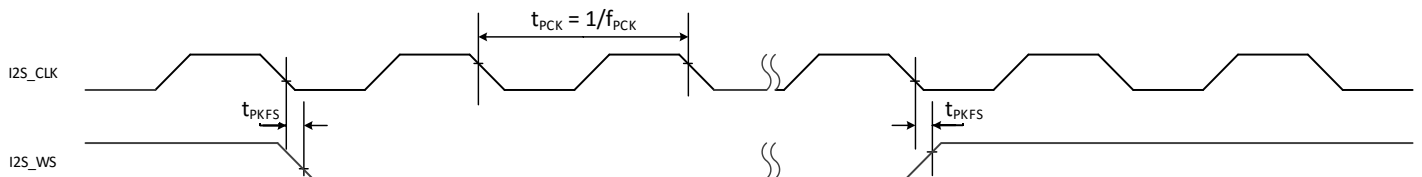

Figure 16 I²S/TDM Interface Master Timing

In Master Mode, I2S_CLK and I2S_WS are outputs, but I2S_SDI and I2S_SDO timing with respect to I2S_CLK are identical to that for Slave mode.



Table 12 I²S/TDM Master Timing

Test Conditions: VDD = 1.8V, 10pF Load, at TA = 25° C, unless otherwise specified. Measurement levels on waveforms are Vih and Vil. ^{Note 1}

Parameter	Symbol	Min	Typ	Max	Units
I2S_WS Output Delay from CLK ↓ ^{Note 2}	tPKFS	0		25%	tPCK

Note 1: Timing parameters are guaranteed by design and they are not tested in the final test.

Note 2: The I2S_WS outputs are set to drive at the falling edge of the I2S_CLK. Delay from CLK ↓ to I2S_CLK is determined by an integer number of periods of an internal oversampling clock used to generate both I2S_CLK and I2S_WS.

6.4.3 Audio Port PDM Interface Characteristics

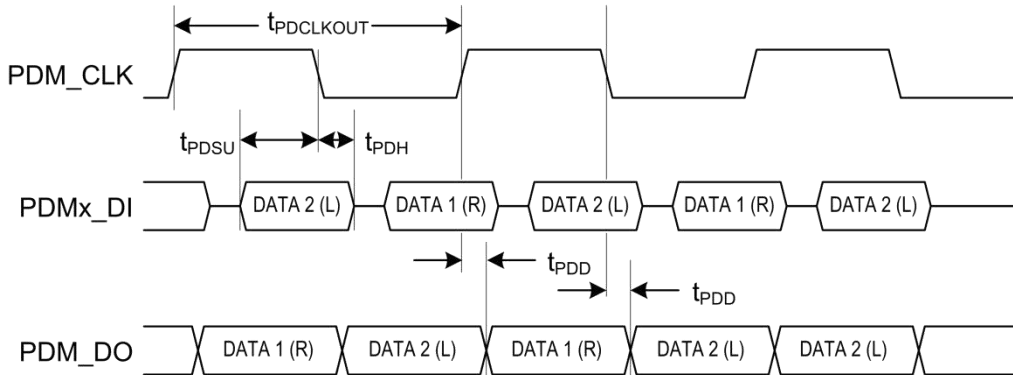
Figure 17 PDM Interface Timing
Table 13 PDM Timing

Test Conditions: VDD = 1.8V, 10pF Load, at TA = 25° C, unless otherwise specified.

Parameter	Symbol	Min	Typ	Max	Units
PDM_CLK Output Frequency, Operating	fPDCLKOUT	0.512	3.072	4.800	MHz
PDM_CLK Output Frequency, Low-power Voice Wake Mode		0.512	0.768 Nominal		MHz
PDM Data Input Setup Time to Clock Edge	tPDSU	25			ns
PDM Data Input Hold Time after Clock Edge	tPDH	3			ns
PDM Data Delay from PDM_CLK Edge ²	tPDD	6			ns

Note 1: Timing parameters are guaranteed by design; they are not tested in the final test.

Note 2: The edge of the clock on which data is output is programmable.

6.5 I²C Slave Interface Characteristics

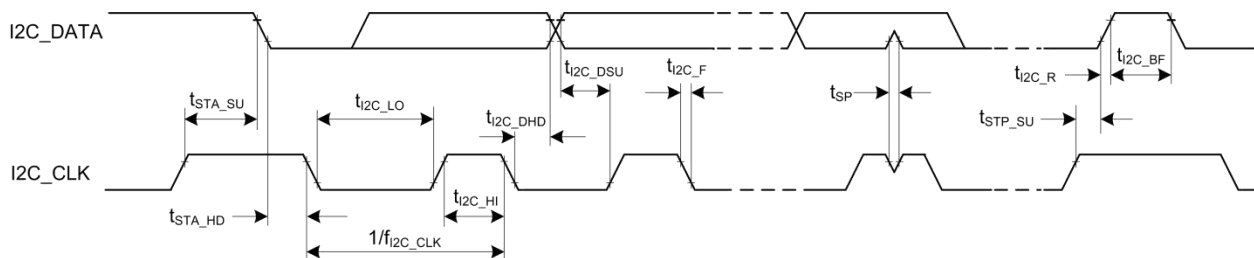
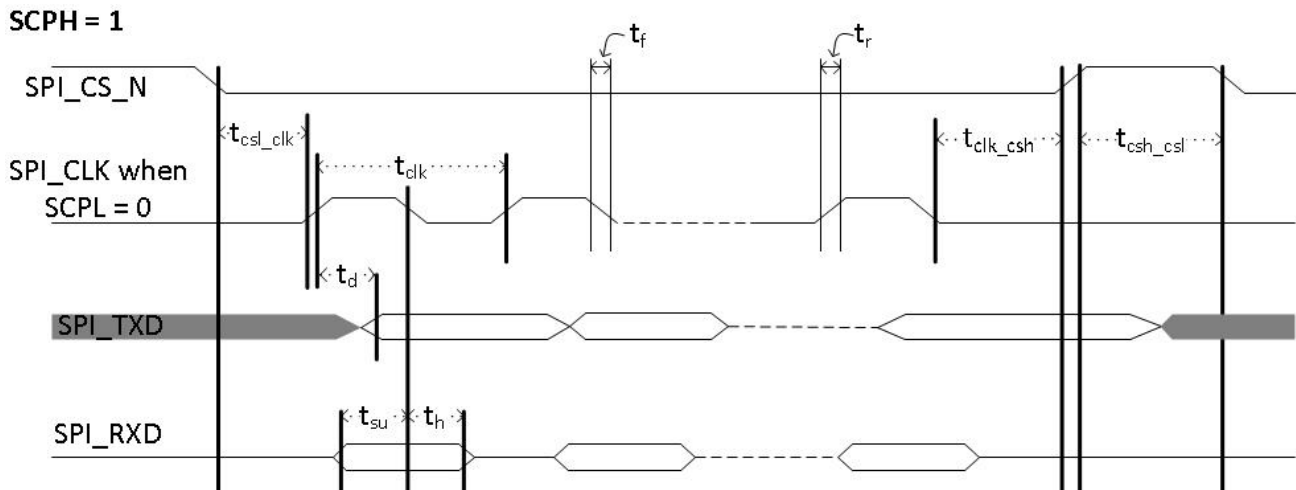

Figure 18 I²C Slave Interface Timing

Table 14 I²C Slave Timing
Test Conditions: VDD = 1.8V, Output Load = 20pF, unless otherwise specified.

Parameter	Symbol	Standard Mode		Fast Mode		Fast Mode+ ¹		Units
		Min	Max	Min	Max	Min	Max	
I ² C Clock Frequency	f _{I2C_CLK}	0	100	0	400	0	1000	kHz
I ² C Clock High Period	t _{I2C_HI}	4.0		0.6		0.26		μs
I ² C Clock Low Period	t _{I2C_LO}	4.7		1.3		0.5		μs
Start Condition Setup Time	t _{STA_SU}	4.7		0.6		0.26		μs
Start Condition Hold Time	t _{STA_HD}	4.0		0.6		0.26		μs
Stop Condition Setup Time	t _{STP_SU}	4.0		0.6		0.26		μs
Bus Free Time between Stop and Start Conditions	t _{I2C_BF}	4.7		1.3		0.5		μs
I ² C Clock and Data Rise Time	t _{I2C_R}	-	1000	20	300	-	120	ns
I ² C Clock and Data Fall Time	t _{I2C_F}		300		300		120	ns
I ² C Data Setup Time	t _{I2C_DSU}	250		100		50		ns
I ² C Data Hold Time	t _{I2C_DHD}	0	202	0	202	0	-	ns
Spike Suppression Period	t _{SF}	0	0	0	50	0	50	ns

6.6 SPI Interface Specifications

Figure 19 SPI Interface Timing

On reset, the SPI clock phase is set to SCPH=1, and the clock polarity is set to SCPL=0 in bootloader auto-detect mode. The SPI interface is 32-bit. See the IA61x API Guide for enabling the SPI interface in bootloader mode.

Table 15 SPI Timing SCPH = 1

Test Conditions: VDD = 1.8V, >=6x oversampling, 10pF Load, at T_A = 25° C, unless otherwise specified.

Parameter	Symbol	Min	Typ	Max	Units
SPI sample clock frequency	f _{samp}	-		43	MHz
SPI sample clock period	T _{samp}	23.25		-	ns
SPI clock frequency	f _{clk}	-		13	MHz
SPI clock period	t _{clk}	76.92		-	ns
Chip select assert to clock edge	t _{csi_clk}	1		-	t _{clk}
Clock edge to chip select de-assert	t _{clk_csh}	1		-	t _{clk}
Chip select de-assert to chip select assert	t _{csh_csl}	1		-	t _{clk}
Tx data valid from clock edge	t _d	-		64.125	ns
Rx data setup time	t _{su}	0.5		-	t _{samp}
Rx data hold time	t _h	1.5		-	t _{samp}
SPI clock rise time	t _r	-		10%	t _{clk}
SPI clock fall time	t _f	-		10%	t _{clk}



Chapter 7: PCB Design and Layout Guidelines

7.1 Power Planes

Power supply noise can have a significant impact on the performance of analog circuitry in the system. Use low impedance power planes with decoupling capacitors for the system power supply design.

Place ceramic SMT bypass capacitors (1 μF) next to the IA611 VDD power input pin, as well as the LDOD pin (see Figure 20). Additional decoupling capacitors (0.1 μF) may be necessary to reduce the noise on the power pin. Keep routing traces for the decoupling capacitors as short as possible. A long trace has an antenna effect that can introduce additional noise into the power supply, which requires additional filtering.

7.2 Digital Signal Routing

Follow good design practices in the PCB layout by keeping the digital signal traces as short as possible and away from analog and RF signals.

7.3 Typical Application

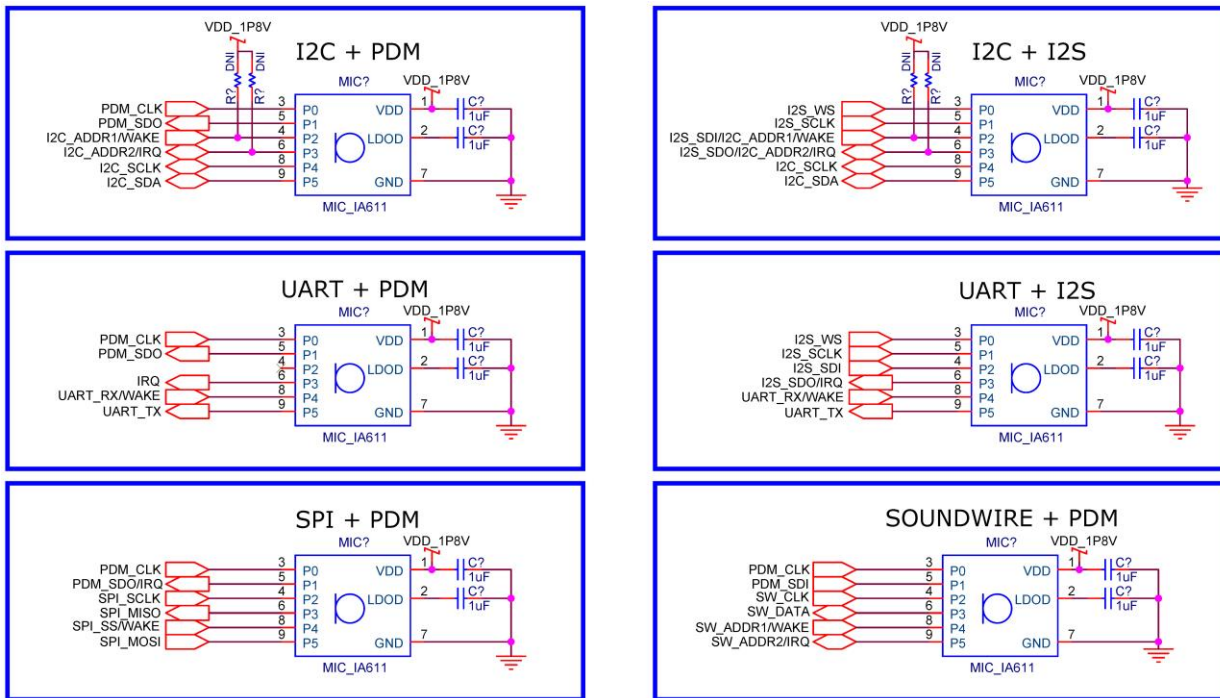

Figure 20 Schematics of Connections for Various Interface Configurations



Chapter 8: Mechanical Specifications

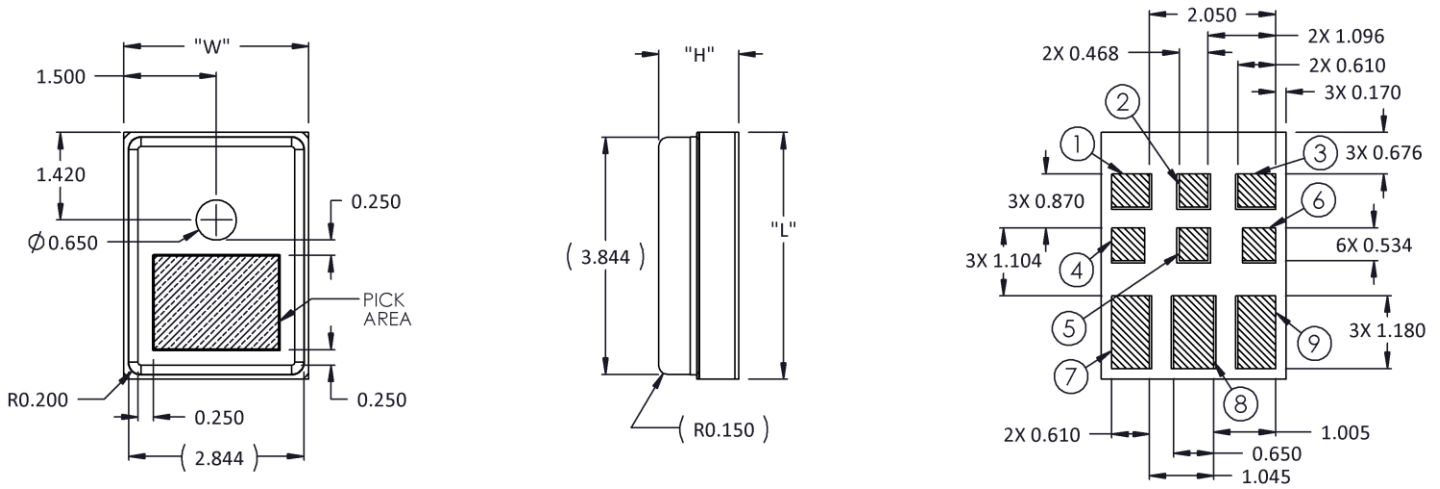
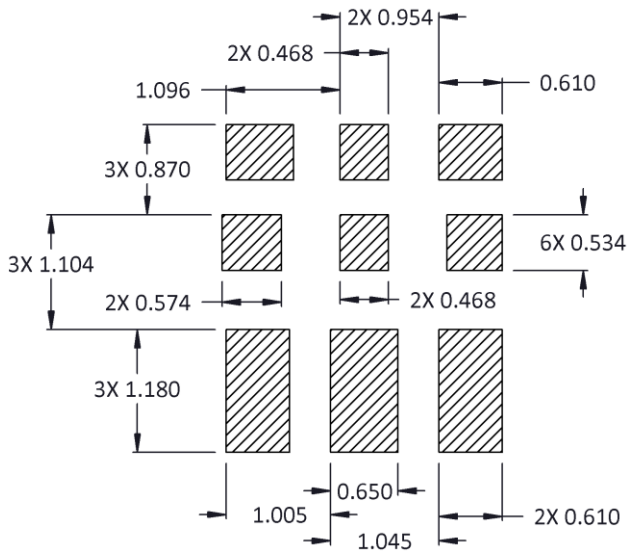

Table 16 Mechanical Specifications

Item	Dimension	Tolerance	Units
Length (L)	4.00	± 0.10	mm
Width (W)	3.00	± 0.10	mm
Height (H)	1.30	± 0.15	mm
Acoustic Port (AP)	0.65	± 0.05	mm

8.1 Example Land Pattern



8.2 Example Solder Stencil Pattern

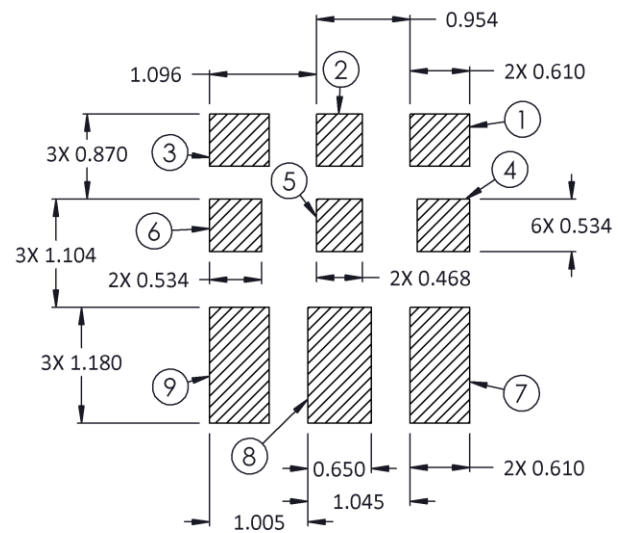

Notes: Pick Area only extends to 0.25 mm of any edge or hole, unless otherwise specified.

Dimensions are in millimeters, unless otherwise specified.

Tolerance is ± 0.15 mm, unless otherwise specified.

Detailed information on AP size considerations can be found in the latest *SiSonic™ Design Guide* application note.

Perform further optimizations based on application.

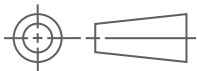

Chapter 9: Packaging and Marking Details

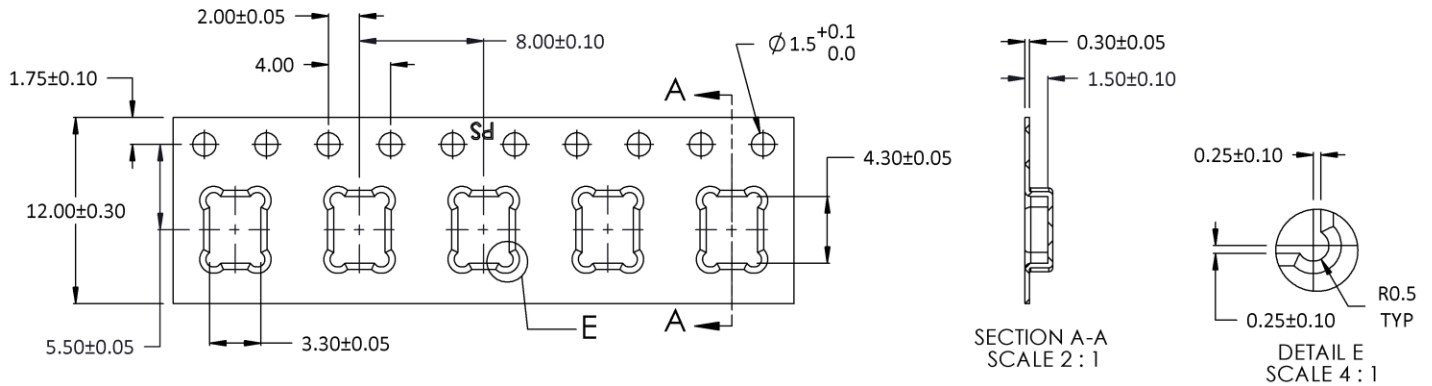
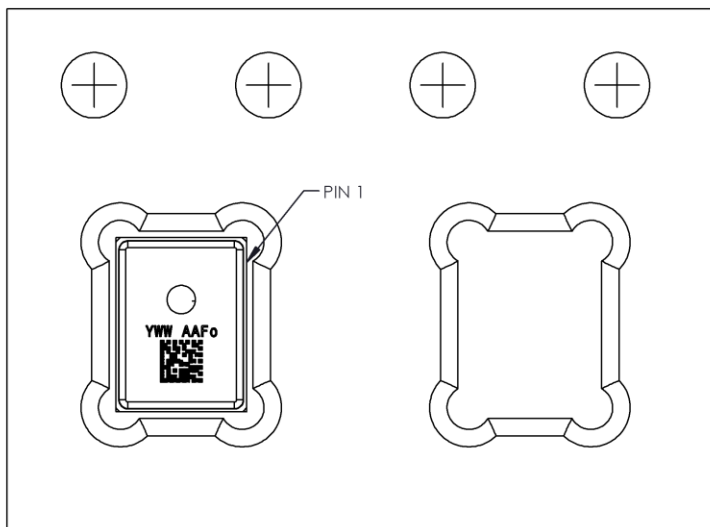

Table 17 Model and Part Numbers

Model Number	Part Number	Quantity Per Reel
IA611	SPK2611HM7H-1-6	4800



2D barcode serial number: PPPYWWDMSSSSAARD

PPP = Vendor/Facility code

KEM = FF9

KES = FMV

KEI = FF8

Y = Last digit of current year

WW = Work week

D = Day, Sunday is 1 and Saturday is 7

MSSSS = 5 digit serial code

M = Machine ID for laser

SSSS = Base 34 serial number

(Do not use letter I or O)

AA = Project name designator

AD: Shakira

R = Revision number

D = Development Stage

E = Engineering Sample

P = Prototype Sample

M = Mass production

Notes: Dimensions are in millimeters unless, otherwise specified.

Vacuum pickup only in the pick area indicated in Mechanical Specifications.

Tape and reel per EIA-481.

Labels are applied directly to reel and external package.

Shelf life: Twelve (12) months when devices are to be stored in factory supplied, unopened ESD moisture-sensitive bag under maximum environmental conditions of 30°C, 70% R.H.



Chapter 10: Recommended Reflow Profile

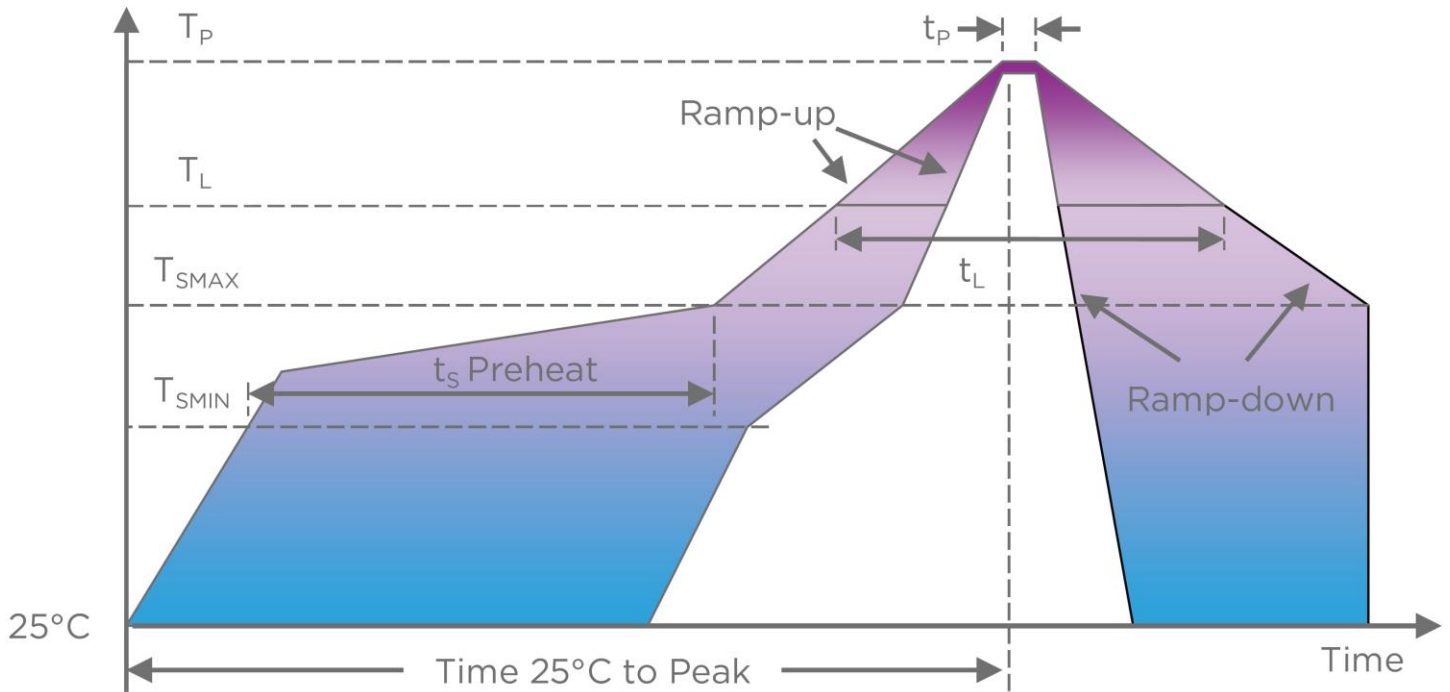

Figure 21 Recommended Reflow Profile

Table 18 Profile Specifications

Profile Feature	Pb-Free
Average Ramp-up rate (T_{SMAX} to T_P)	3°C/second max.
Preheat	
– Temperature Min (T_{SMIN})	150°C
– Temperature Max (T_{SMAX})	200°C
– Time (T_{SMIN} to T_{SMAX}) (t_s)	60-180 seconds
Time maintained above:	
– Temperature (T_L)	217°C
– Time (t_L)	60-150 seconds
Peak Temperature (T_P)	260°C
Time within 5°C of actual Peak Temperature (t_p)	20-40 seconds
Ramp-down rate (T_P to T_{SMAX})	6°C/second max
Time 25°C to Peak Temperature	8 minutes max

Notes: Based on IPC/JDEC J-STD-020 Revision C.

All temperatures refer to topβside of the package, measured on the package body surface.



Chapter 11: Additional Notes

1. Moisture sensitivity level (MSL) Class 1.
2. Maximum of three reflow cycles is recommended.
3. To minimize device damage:
 - Do not board-wash or clean after the reflow process.
 - Do not brush board with, or without, solvents after the reflow process.
 - Do not directly expose to ultrasonic processing, welding, or cleaning.
 - Do not insert any object in port hole of device at any time.
 - Do not apply over 30 psi of air pressure into the port hole.
 - Do not pull a vacuum over port hole of the SmartMic.
 - Do not apply a vacuum when repacking into sealed bags at a rate faster than 0.5 atm/sec.



Chapter 12: Materials Statement

Meets the requirements of the European RoHS directive 2011/65/EC as amended.

Meets the requirements of the industry standard IEC 61249-2-21:2003 for halogenated substances and Knowles Green Materials Standards Policy section on Halogen-Free.

Ozone-depleting substances are not used in the product or the processes used to make the product, including compounds listed in Annex A, B, and C of the “Montreal Protocol on Substances That Deplete the Ozone Layer.”



Chapter 13: Reliability Specifications

Table 19 Reliability Test Specifications

Test	Description
Reflow	5 reflow cycles with peak temperature of +260°C
High Temperature Storage	+105°C environment for 1,000 hours (IEC 68-2-2 Test Ba)
Low Temperature Storage	-40°C environment for 1,000 hours (IEC 68-2-1 Test Aa)
High Temperature Bias	+105°C environment while under bias for 1,000 hours (IEC 68-2-2 Test Ba)
Low Temperature Bias	-40°C environment while under bias for 1,000 hours (IEC 68-2-1 Test Aa)
Temperature/Humidity Bias	+85°C/85% R.H. environment while under bias for 1,000 hours (JESD22-A101A-B)
Thermal Shock	100 cycles of air-air thermal shock from -40°C to +125°C with 15 minute soaks (IEC 68-2-4)
Tumble Test	300 Random Drops of Test Box on to Steel Base from 1.0m, 10 Tumbles/Minute
Vibration	16 minutes in each X, Y, Z axis from 20 to 2,000 Hz with peak acceleration of 20 G (MIL 883E, Method 2007.2,A)
Mechanical Shock	3 pulses of 10,000 G in each of the X, Y, and Z directions (IEC 68-2-27 Test Ea)
ESD-HBM	3 discharges of ±2kV direct contact to I/O pins (MIL 883E, Method 3015.7)
ESD-LID/GND	3 discharges of ±8kV direct contact to lid while unit is grounded (IEC 61000-4-2)
ESD-MM	3 discharges of ±200V direct contact to IO pins (ESD STM5.2)

Notes: The SmartMic must meet all acoustic and electrical specifications before and after reliability testing.
 After three reflow cycles, the sensitivity of the SmartMic must not deviate more than 1 dB from its initial value.



Revision History

Revision	Description	Date
1.0	Initial release.	21-Mar-2019
1.1	Minor corrections throughout.	08-Apr-2019
1.2	Updated Table 17.	09-March-2021

Material contained in this document may not be copied, reproduced, reduced to any electronic medium or machine readable form or otherwise duplicated and the information herein may not be used, disseminated or otherwise disclosed, except with the prior written consent of an authorized representative of Knowles, Inc. Knowles is a registered trademark of Knowles Corporation. All other trademarks are the properties of their respective owners.