

- NOTES:**
- MATERIAL: HOUSING - LIQUID CRYSTAL POLYMER (LCP) GLASS-FILLED. UL 94V-0. COLOR - GRAY. SIGNAL CONTACT AND GROUND BLADE - HIGH PERFORMANCE COPPER ALLOY.
 - FINISHES: SELECTIVE GOLD (Au) ON CONTACT AREA, SELECTIVE MATTE TIN (Sn) ON PCB TAILS, NICKEL (Ni) OVERALL.
 - THIS PART CONFORMS TO MOLEX PRODUCT SPECIFICATION PS-75221-999.
 - FOR MIXED CONTACT MATING LENGTHS CONSULT MOLEX FOR AVAILABILITY. CONTACT PAIRS MUST BE THE SAME LENGTH.
 - FOR SPECIFIC PART NUMBER AND MATING INFORMATION PLEASE REFER TO CHART.
 - PACKAGE PER PK-70873-505.
 - MARK PART NUMBER AND DATE CODE APPROXIMATELY WHERE SHOWN.
 - OPTIONAL HOLE LOCATION FOR GROUNDED GUIDE PIN OR ADDITIONAL GUIDE PIN SUPPORT. FOR GROUNDED GUIDE PIN, HOLE TO BE PLATED, DRILL SIZE #258. PAD SIZE #550.
 - THESE PARTS CONFORM TO MOLEX COSMETIC SPECIFICATION PS-45499-002 CLASS B.
 - MAPS (MOLEX ADVANCED PLATING SYSTEM).

MODULE ORIENTATION
 2 = LEFT

75237-2***

KEYING ORIENTATION (SEE TABLE)

ROWS AG & NG RECOMMENDED FOR ALL APPLICATIONS. THESE ROWS SHOULD BE CONNECTED TO GROUND

PIN LENGTH DIM 'M'	GOLD (Au) THICKNESS micrometers
0=3.55 mm	0.25 (MAPS)
1=4.55 mm	
2=5.55 mm	
3=3.55 mm	
4=4.55 mm	
5=5.55 mm	1.27
7=3.55 mm	
8=4.55 mm	
9=5.55 mm	

ASSY PART NO.	K	L	P	TOTAL NO. OF DIFFERENTIAL PAIRS
75237-210*	9	16.65	24.78	50
75237-220*	24	44.40	52.53	125

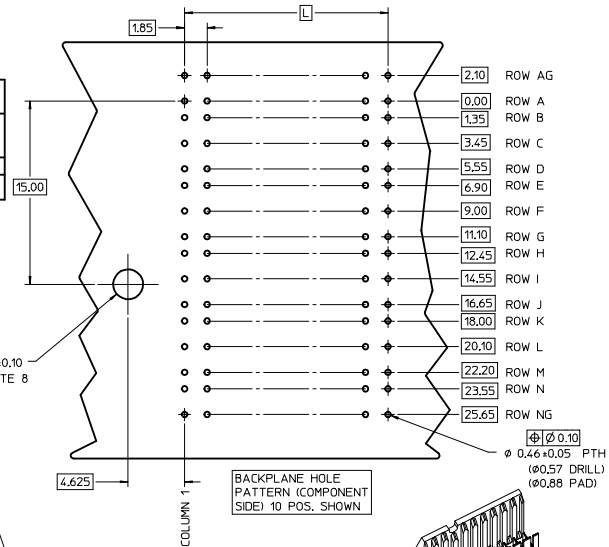

THE PRIMARY CARTON WITH A LABEL STATING "ELV AND RoHS COMPLIANT" IS LEAD FREE. CARTONS WITHOUT THIS LABEL MAY CONTAIN LEAD.

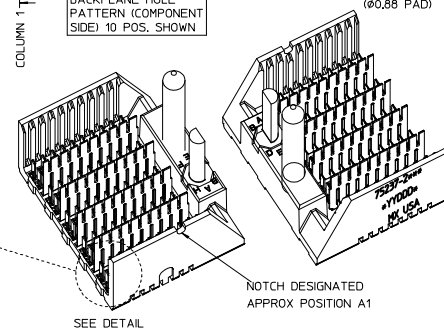
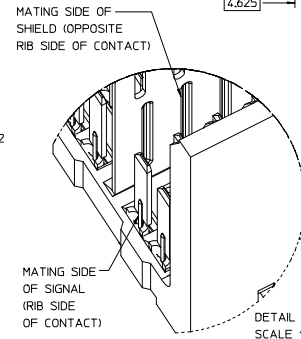
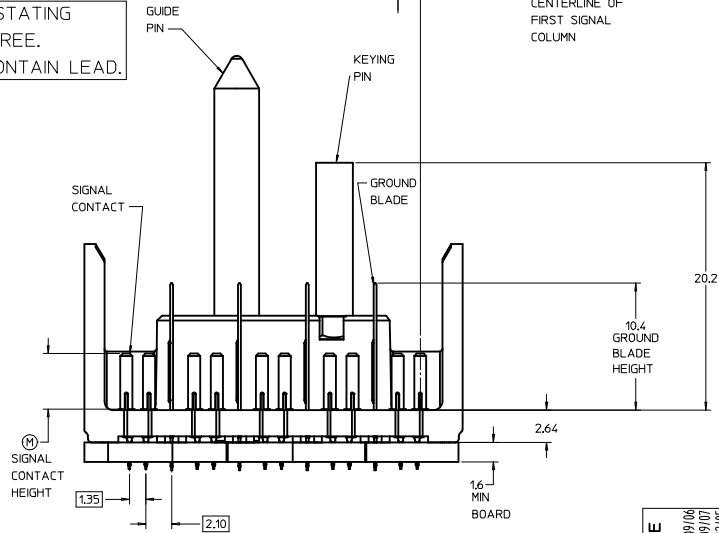
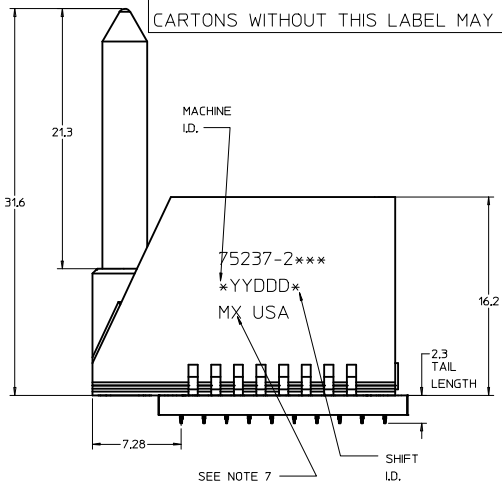

LEAD-FREE PLATING

P/N	KEYING PIN ORIENTATION	0	A	B	C	D	E	F	G	H
75237-()										

REV TO LEAD-FREE IEC NO. LCP 2013-0690 DRAWINGS 2012/09/06 CHYK/MOLEE 2012/09/07 APPROX/MILLER 2012/12/05	QUALITY SYMBOLS	GENERAL TOLERANCES (UNLESS SPECIFIED)	DIMENSION STYLE	SCALE	DESIGN UNITS	THIRD ANGLE PROJECTION
	▽=0	4 PLACES ±--- ±---	MM ONLY	5:1	METRIC	
	▽=0	3 PLACES ±--- ±---				
	▽=0	2 PLACES ±0.25 ±---				
		1 PLACE ±0.38 ±---				
		0 PLACE ± ±				
		ANGULAR ±1/2°				
		DRAFT WHERE APPLICABLE MUST REMAIN WITHIN DIMENSIONS				
			MATERIAL NO.	DOCUMENT NO.		
			SEE CHART	SD-75237-210		
						SHEET NO. 1 OF 1

GBX 5-PAIR LF LEFT END BACKPLANE SALES ASSEMBLY

molex

SD-75237-210