

| PART NUMBER | REV      | FIRST USED |
|-------------|----------|------------|
| 466471-1    | F        | 122500-1   |
| 466471-2    | F        | 565435-5   |
| 466471-3    | SEE DRWG | 466471-3   |
| 466471-4    | H        | 354500-1   |

OBS

OBS

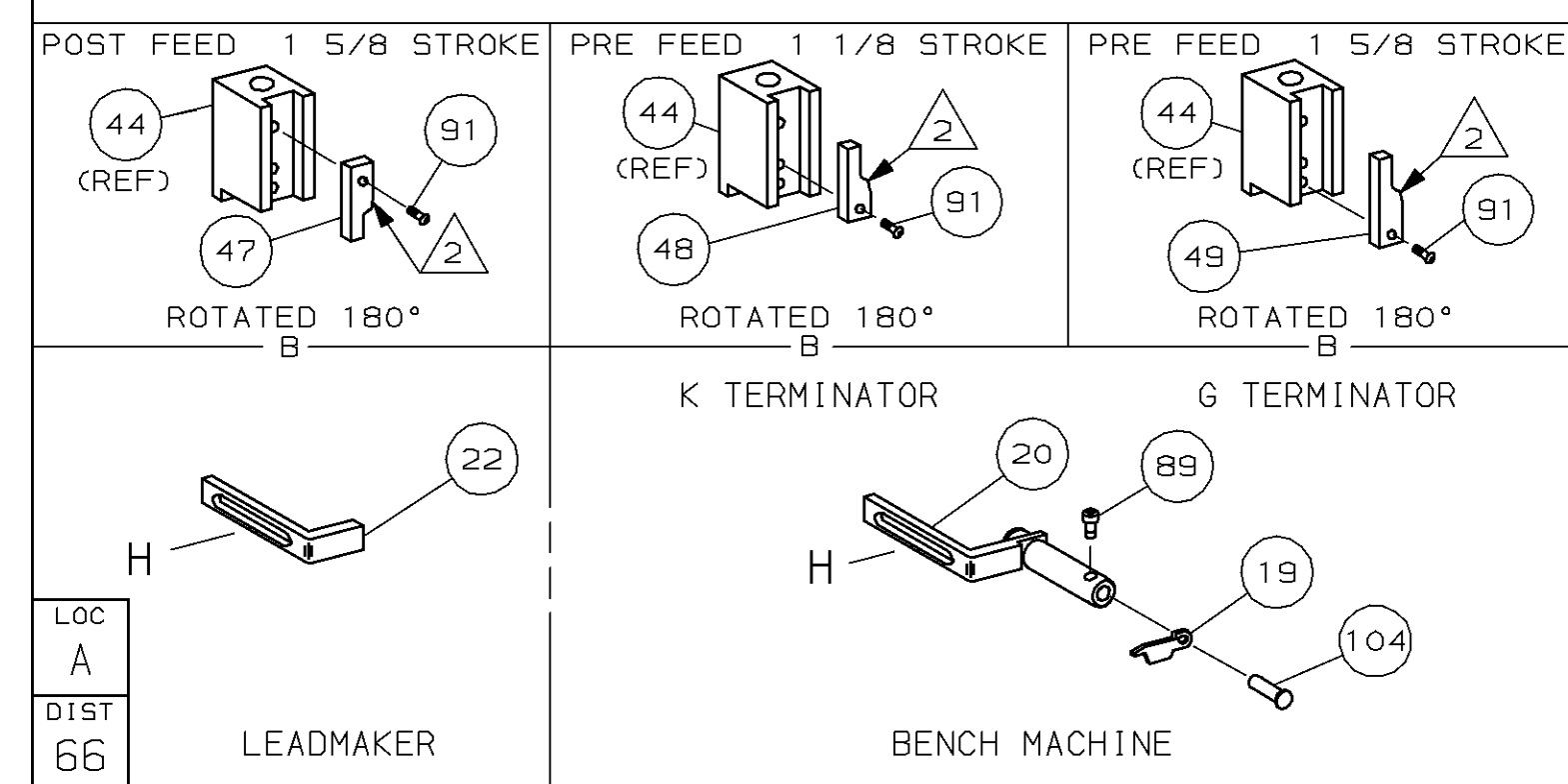
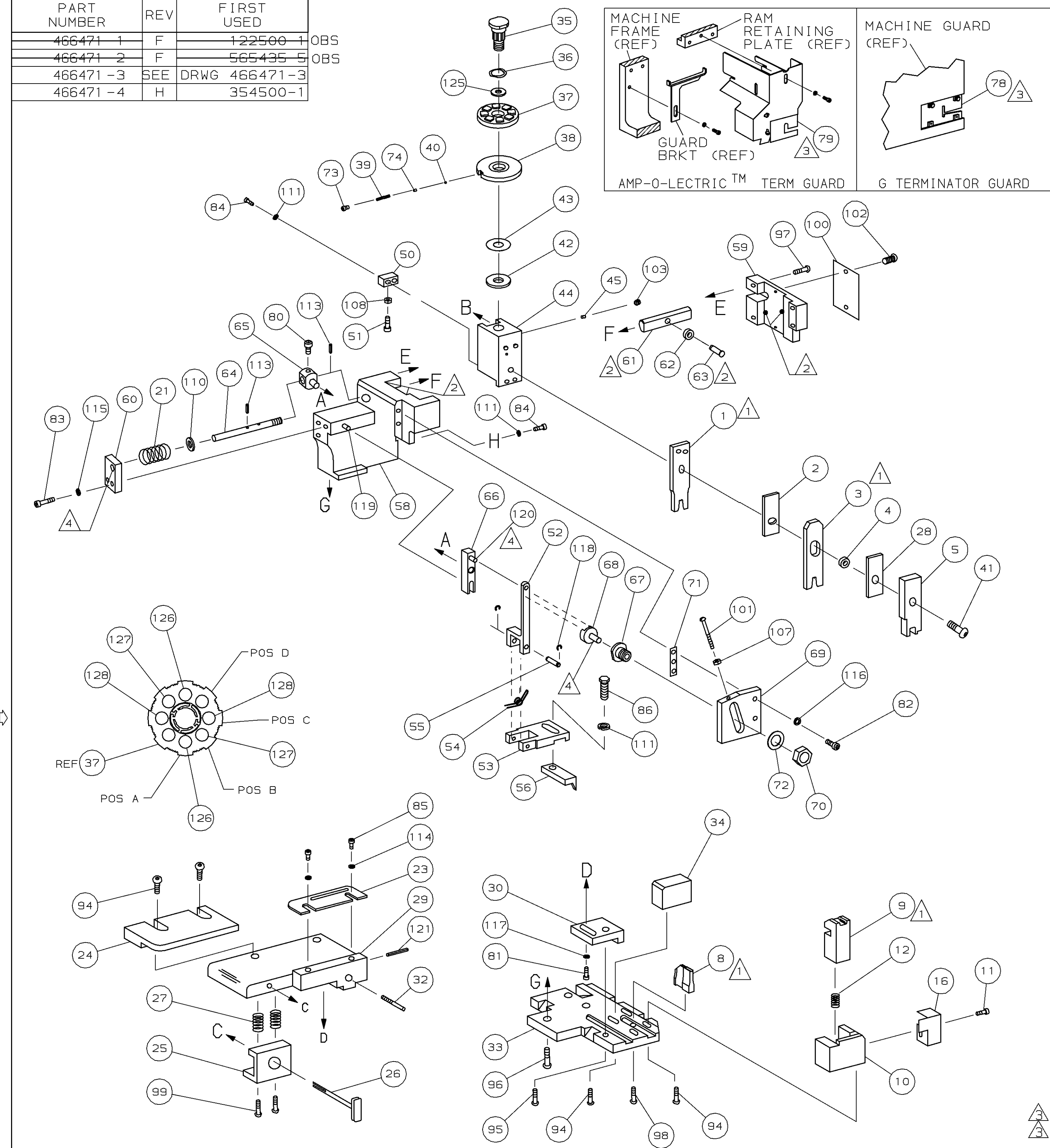

- 1 RECOMMENDED SPARE PARTS.
- 2 GREASE LIGHTLY.
- 3 GUARD MUST BE IN PLACE WHEN OPERATING APPLICATOR IN A BENCH MACHINE.
- 4 LUBRICATE DAILY USING NO. 20 MACHINE OIL.
- 5. ITEMS WITH QTY OF REF SPECIFIED (EXCEPT ITEMS 78 AND 79) ARE USED ON ITEM 46.
- 6 .080 INSULATION CRIMPER OVER .070 ANVIL
- 7

| WIRE STRIP LENGTH |  | TERM APPL SPEC | FEED | APPL INSTRUCTION | SET UP GAGE | LAYOUT |
|-------------------|--|----------------|------|------------------|-------------|--------|
| -                 |  | 114-1017       | .320 | 408-8040         | 458637-1    | 845    |

| QTY REQD PER ASSY |     | PARTS LIST |   | DESCRIPTION | ITEM NO    |                                 |     |
|-------------------|-----|------------|---|-------------|------------|---------------------------------|-----|
| 2                 | 2   | 2          | - | C           | 4-354779-6 | PIN, WIRE DISC (.3220)C         | 129 |
| 2                 | 2   | 2          | - | C           | 3-354779-8 | PIN, WIRE DISC (.3180)B         | 127 |
| 2                 | 2   | 2          | - | C           | 3-354779-2 | PIN, WIRE DISC (.3150)A         | 126 |
| 1                 | 1   | 1          | - | A           | 986950-1   | WASHER, FLAT PRECISION          | 125 |
| 1                 | 1   | 1          | - | A           | 217238-1   | GENERAL INSTRUCTION PACKAGE     | 124 |
| 1                 | 1   | 1          | - | -           | 4088040    | SF APPL INST 408-8040           | 123 |
| 1                 | 1   | 1          | - | A           | 4-21028-0  | PIN,SLT SPR(φ.093x.75)ST GDE PL | 121 |
| REF               | REF | REF        | - | A           | 1-21030-1  | PIN,DOWL(φ.187x.50)LEVER        | 120 |
| REF               | REF | REF        | - | A           | 1-21030-6  | PIN,DOWL(φ.187x1.25)HOUSING     | 119 |
| REF               | REF | REF        | - | A           | 21045-3    | RING,RET "C"(φ.187)FD FING PIN  | 118 |
| 1                 | 1   | 1          | - | A           | 21024-5    | WASHER, LOCK (#10)ADJ BLK       | 117 |
| REF               | REF | REF        | - | A           | 21024-5    | WASHER,LOCK(#10)ADJ PLATE       | 116 |
| REF               | REF | REF        | - | A           | 21024-5    | WASHER,LOCK(#10)FEED GDE ROD    | 115 |
| 2                 | 2   | 2          | - | A           | 21024-2    | WASHER,LOCK(#4)FRONT STP GUIDE  | 114 |
| REF               | REF | REF        | - | A           | 5-21028-1  | PIN,SLT SPR(φ.125x.50)ADJ ROD   | 113 |
| 4                 | 4   | 4          | - | A           | 21024-4    | WASHER,LOCK(#8)STRIPPER         | 111 |
| REF               | REF | REF        | - | A           | 21899-4    | WASHER,FLAT(φ5/16)SCREW ADJ     | 110 |
| 1                 | 1   | 1          | - | A           | 21018-5    | NUT,HEX(NO.6)HOLDDOWN           | 109 |
| REF               | REF | REF        | - | A           | 21018-5    | NUT,HEX(6-32)FEED ADJ           | 107 |
| 1                 | 1   | 1          | - | A           | 992031-1   | PIN, CLEVIS                     | 104 |
| 1                 | 1   | 1          | - | A           | 21009-2    | SCR,SKT SET(1/4-20x.25 LW)RAM   | 103 |
| 2                 | 2   | 2          | - | A           | 21017-2    | SCR,DRIVE(#2x.19)ID PLATE       | 102 |
| REF               | REF | REF        | - | A           | 6-23715-5  | SCR,PAN HD(6-32x1.50)FEED ADJ   | 101 |
| 1                 | 1   | 1          | - | B           | 461264-1   | PLATE, IDENTIFICATION           | 100 |
| 2                 | 2   | 2          | - | A           | 3-21002-0  | SCR,BHC(10-32x.88)DRAG          | 99  |
| 1                 | 1   | 1          | - | A           | 22733-8    | SCR,BHC(8-32x.38 LW)ANVIL       | 98  |
| REF               | REF | REF        | - | A           | 2-21002-9  | SCR,BHC(10-32x.75)CAP           | 97  |
| REF               | REF | REF        | - | A           | 2-22733-8  | SCR,BHC(1/4-20x.62)HOUSING      | 96  |
| REF               | REF | REF        | - | A           | 2-21002-7  | SCR,BHC(10-32x.50)SG ADJ BLOCK  | 95  |
| 6                 | 6   | 6          | - | A           | 2-21002-2  | SCR,BHC(8-32x.50)TERM H DWN     | 94  |
| 1                 | 1   | 1          | - | A           | 1-21002-7  | SCR,BHC(6-32x.38)CAM            | 91  |
| 1                 | 1   | -          | - | A           | 7-21000-9  | SCR,SHC(4-40x.19)STRIPPER       | 89  |
| 1                 | 1   | 1          | - | A           | 2-22603-0  | SCR,HEX HD(8-32x.31)FEED FINGER | 86  |
| 2                 | 2   | 2          | - | A           | 1-21000-3  | SCR,SHC(4-40x.25)F ST GUIDE     | 85  |
| 3                 | 3   | 3          | - | A           | 2-21000-7  | SCR,SHC(8-32x.50)STRIPPER       | 84  |
| REF               | REF | REF        | - | A           | 3-21000-7  | SCR,SHC(10-32x.75)FEED ROD GD   | 83  |
| REF               | REF | REF        | - | A           | 3-21000-6  | SCR,SHC(10-32x.62)FD ADJ BLK    | 82  |
| 1                 | 1   | 1          | - | A           | 3-21000-4  | SCR,SHC(10-32x.38)SG ADJ BL     | 81  |
| REF               | REF | REF        | - | A           | 3-21000-4  | SCR,SHC(10-32x.38)PIVOT BLK     | 80  |
| -                 | REF | -          | - | B           | 455749-1   | GUARD, WINDOW                   | 79  |
| REF               | -   | -          | - | B           | 679532-1   | INSERT, GUARD                   | 78  |
| 1                 | 1   | 1          | - | A           | 690603-1   | SPRING, ASSIST                  | 74  |
| 1                 | 1   | 1          | - | A           | 23030-1    | SCR,SHC(6-32x.25 SL)INS DISC    | 73  |
| REF               | REF | REF        | - | A           | 458109-1   | WASHER, SPECIAL                 | 72  |
| REF               | REF | REF        | - | A           | 690517-1   | SPACER                          | 71  |

| QTY REQD PER ASSY |     | PARTS LIST |   | DESCRIPTION | ITEM NO    |                             |    |
|-------------------|-----|------------|---|-------------|------------|-----------------------------|----|
| 1                 | 1   | 1          | - | B           | 690542-2   | PAWL, FEED                  | 56 |
| REF               | REF | REF        | - | B           | 240624-1   | PIN, FEED FINGER            | 55 |
| REF               | REF | REF        | - | B           | 691499-1   | SPRING, FEED FINGER         | 54 |
| REF               | REF | REF        | - | B           | 690541-1   | HOLDER, FEED FINGER         | 53 |
| REF               | REF | REF        | - | A           | 455679-1   | LEVER, TERMINAL FEED ARM    | 52 |
| 1                 | 1   | 1          | - | A           | 811242-2   | BUMPER, HOLDDOWN            | 51 |
| 1                 | 1   | 1          | - | A           | 690753-1   | SPACER, TONKER              | 50 |
| 1                 | -   | -          | - | B           | 690602-6   | CAM, PRE-FEED 1 5/8 ST      | 49 |
| -                 | 1   | -          | - | B           | 690602-5   | CAM, PRE-FEED 1 1/8 ST      | 48 |
| -                 | -   | 1          | - | B           | 690501-4   | CAM, POST-FEED 1 5/8 ST     | 47 |
| 1                 | 1   | 1          | - | B           | 459456-1   | APPLICATOR, BASIC (SUBASSY) | 46 |
| 1                 | 1   | 1          | - | A           | 690191-1   | PLUG, NYLON                 | 45 |
| 1                 | 1   | 1          | - | C           | 455673-1   | RAM                         | 44 |
| 1                 | 1   | 1          | - | A           | 690125-1   | WASHER, LAMINATED           | 43 |
| 1                 | 1   | 1          | - | A           | 690124-1   | WASHER, RAM                 | 42 |
| 1                 | 1   | 1          | - | A           | 7-21002-9  | BOLT, CRIMPER(5/16x1.00)    | 41 |
| 1                 | 1   | 1          | - | A           | 23241-6    | BALL, STEEL                 | 40 |
| 1                 | 1   | 1          | - | A           | 690170-1   | SPRING, COMPRESSION         | 39 |
| 1                 | 1   | 1          | - | C           | 690142-1   | DISC, INSULATION            | 38 |
| 1                 | 1   | 1          | - | D           | 354777-1   | WIRE DISC, PLASTIC          | 37 |
| 1                 | 1   | 1          | - | A           | 22480-5    | WASHER, SPRING              | 36 |
| 1                 | 1   | 1          | - | B           | 690212-1   | POST, RAM                   | 35 |
| 1                 | 1   | 1          | - | B           | 1-690786-4 | SUPPORT, TERMINAL           | 34 |
| REF               | REF | REF        | - | D           | 455675-1   | PLATE, BASE                 | 33 |
| 1                 | 1   | 1          | - | A           | 690432-3   | SCREW, ADJUSTMENT           | 32 |
| REF               | REF | REF        | - | B           | 455689-1   | BLOCK, STRIP GUIDE ADJ      | 30 |
| 1                 | 1   | 1          | - | C           | 455671-1   | PLATE, STRIP GUIDE          | 29 |
| 1                 | 1   | 1          | - | C           | 1-455888-0 | SPACER, FRONT SHEAR DEP     | 28 |
| 2                 | 2   | 2          | - | A           | 1-22284-0  | SPRING, DRAG                | 27 |
| 1                 | 1   | 1          | - | B           | 690546-1   | LEVER, DRAG RELEASE         | 26 |
| 1                 | 1   | 1          | - | B           | 240792-1   | DRAG, TERMINAL              | 25 |
| 1                 | 1   | 1          | - | D           | 690504-1   | GUIDE, STRIP (REAR)         | 24 |
| 1                 | 1   | 1          | - | A           | 690438-1   | GUIDE, STRIP (FRONT)        | 23 |
| -                 | -   | 1          | - | B           | 690472-2   | STRIPPER                    | 22 |
| REF               | REF | REF        | - | A           | 4-22284-9  | SPRING, FEED RETURN         | 21 |
| 1                 | 1   | -          | - | A           | 679218-1   | STRIPPER WIRE STOP ASSY     | 20 |
| 1                 | 1   | -          | - | B           | 458949-1   | STRIPPER                    | 19 |
| 1                 | 1   | 1          | - | B           | 318563-1   | GUARD, CHIP, FRONT          | 16 |
| 1                 | 1   | 1          | - | A           | 5-22280-0  | SPRING, SHEAR               | 12 |
| 1                 | 1   | 1          | - | B           | 690461-1   | STOP, SHEAR                 | 11 |
| 1                 | 1   | 1          | - | C           | 690459-1   | HOLDER, SHEAR (FRONT)       | 10 |
| 1                 | 1   | 1          | - | C           | 454276-1   | SHEAR, FLOAT (FRONT)        | 9  |
| 1                 | 1   | 1          | - | C           | 4-458834-1 | ANVIL                       | 8  |
| 1                 | 1   | 1          | - | C           | 455889-9   | DEPRESSOR, SHEAR (FRONT)    | 5  |
| 1                 | 1   | 1          | - | B           | 238011-6   | SPACER, BLOCK CRIMPER       | 4  |
| 1                 | 1   | 1          | - | C           | 8-456135-1 | CRIMPER, INSULATION         | 3  |
| 1                 | 1   | 1          | - | C           | 455888-5   | SPACER, CRIMPER             | 2  |
| 1                 | 1   | 1          | - | C           | 1-456404-6 | CRIMPER, WIRE               | 1  |