





# S12 MagniV Mixed-Signal MCUs S12ZVMB Family

Integrated solution for reversible DC motor control applications with H-Bridge

## Features

-  DC Motor Control
-  Integrated LIN PHY
-  V<sub>REG</sub> for 12 V Supply
-  4-ch. MOSFET Gate driver
-  Ultra-reliable Industrial
-  AEC-Q100 Grade0 (150 °C Ta / 175 °C Tj)

## Product One-Pager

**System in a Package**—Highly integrated solution ideal for mechatronic approach to DC motors controlled by LIN or PWM command

**Scalable**—48/64 pin, up to 64 KB flash, up to 150 °C Ta

**High reliability**—High immunity to EMI and ESD stresses, LIN 2.x compliant with +/- 8 kV ESD capability

**Low system cost**—Operating straight from car battery, integrated PHY for LIN, 4-channel motor control MOSFET gate pre-drivers and op-amp for current sensing

**Enablement**—Supported by comprehensive hardware and software solution

## S12ZVMB Specifications

Core	S12Z; 32 MHz bus	HS-Driver	2-ch. 12 V
Flash	48-64 KB	Gate Driver	4-ch. FET Gate driver
RAM	4 KB	PWM	6-ch. motor control PWM
EEPROM	512 B	PTU	Triggering ADC & PWM
Phy	LIN	ADC	5-9 ch, 10 bit
SCI/SPI	2/1	OpAmp	1 x for current sensing
HVI	3	EVDD	1-ch. 5 V / 20 mA (source)
Timer	4ch + 4ch 16-bit	12V VREG	70 mA (170 mA with ext. ballast)
Temp	Up to 150 °C Ta / 175 °C Tj	Op Range	7 V–20 V

## Sample Part Numbers

Part Number	Flash	Temp Range	Package	Available	Test Coverage
P912ZVMB A64F0MLF	64 KB	-40 °C to 125 °C	48 LQFP	Now	3-Temp
P912ZVMB A64F0WLF	64 KB	-40 °C to 150 °C	48 LQFP	Now	3-Temp
P912ZVMB A64F0MLH	64 KB	-40 °C to 125 °C	64 LQFP	Now	3-Temp

## Product Block Diagram

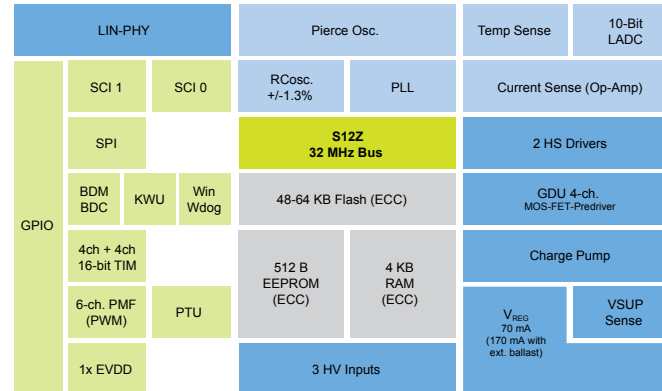

## Application Example Block Diagram

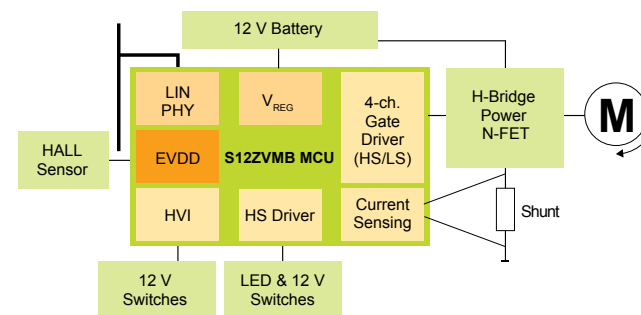

## Target Applications

- ▶ Anti-Pinch window lift
- ▶ Sunroof
- ▶ Automatic doors
- ▶ Power lift gate
- ▶ Seat adjustment
- ▶ Valves (powertrain)
- ▶ Seat belt pretensioner

## Enablement Tools

- ▶ Evaluation Board
  - X-S12ZVMBEVB
- ▶ Compiler/Debugger
  - CodeWarrior® IDE
  - Cosmic IDE
- ▶ LIN Stack

## Availability

Samples & tools available in limited quantity. Please contact local sales representative



[www.NXP.com/S12ZVMB](http://www.NXP.com/S12ZVMB)

NXP, the NXP logo, CodeWarrior and MagniV are trademarks of NXP B.V. All other product or service names are the property of their respective owners. © 2016 NXP B.V.

Document Number: S12ZVMBF5 REV 0

