

ISL29501-CS-EVKIT1Z

Cat Shark Reference Design

The ISL29501-CS-EVKIT1Z is a distance measurement reference design consisting of an optical board and a controller board. It combines the ISL29501 chip with an OSRAM SFH 4550 IR emitting LED and OSRAM SFH 213FA photodiode. The two circuit boards are connected together with a flat flex cable. Included is a USB flash drive containing the evaluation software for a PC and related technical documents.

The ISL29501-CS-EVKIT1Z kit also allows quick evaluation of the ISL29501 performance for a 2m sensing system.

Specifications

This board has been configured and optimized for the following operating conditions:

- Micro USB 2.0 connection
- $V_{IN} = 5V$  (USB power)
- $I_{DD}$  maximum = 225mA
- P optical maximum = 70mW
- Wavelength = 860nm
- Optical duty cycle maximum = 50%
- Emission angle =  $\pm 3^\circ$
- Coherent light - No

Features

- Self contained measurement system
- Enables proximity detection and distance measurement
- Emitter DAC with programmable current up to 255mA
- Operates in continuous or single shot mode
- On-chip active ambient light rejection
- Regulated power 2.7V to 3.3V USB or external supply
- I<sup>2</sup>C interface supporting 1.8V and 3.3V bus
- Small size 38mmx20mm

Kit Contents

- Evaluation Board
- USB cable
- Software
- Technical documentation

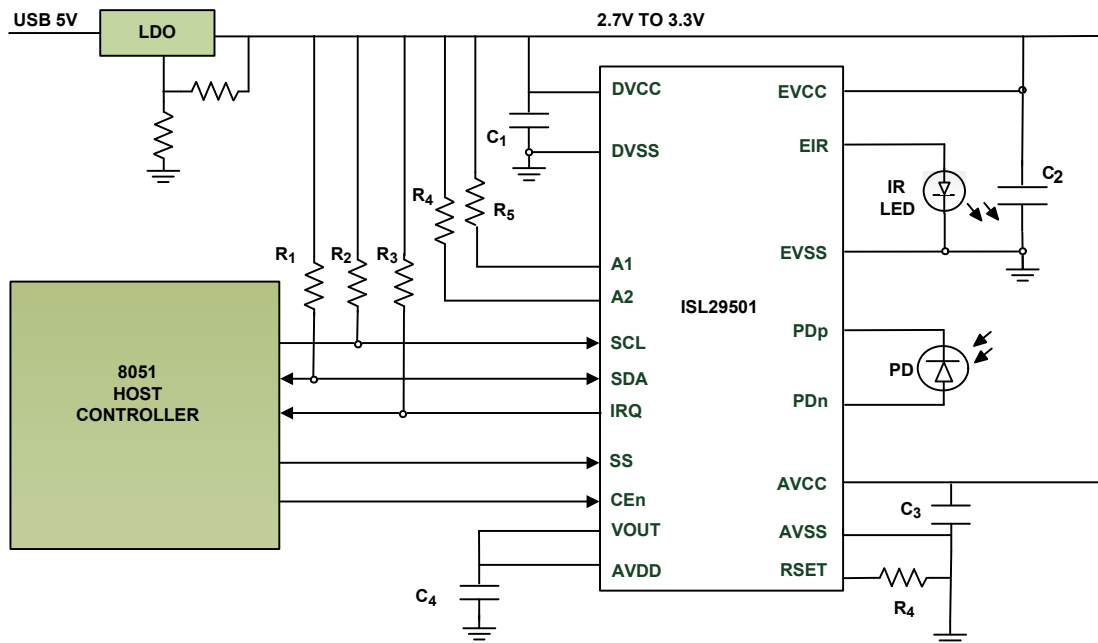

Figure 1. Cat Shark Block Diagram

## Contents

<b>1. Functional Description</b>	<b>3</b>
1.1 Operating Features	3
1.1.1 External Power Supply	3
1.1.2 External Microprocessor	3
1.1.3 System Calibration	3
1.1.4 Calibrating Cat Shark	3
1.2 Operating Range	4
1.3 Quick Start Guide	4
1.4 Changing Settings	4
1.5 Temperature Compensation	4
<b>2. Board Design</b>	<b>5</b>
2.1 Layout Guidelines	5
2.2 Schematic Diagrams	6
2.2.1 ISLI2UEV1Z	6
2.2.2 ISL29501-CS1Z Optics Board	7
2.3 Bill of Materials	8
2.3.1 ISLI2UEV1Z	8
2.3.2 ISL29501-CS1Z Optics Board	9
2.3.3 ISL29501-CS-EVKIT1Z Cat Shark Assembly	10
2.4 Board Layout	11
2.4.1 ISL29501-CS1Z PCB Layers	11
2.4.2 ISLI2UEV1Z PCB Layers	12
<b>3. Ordering Information</b>	<b>12</b>
<b>4. Revision History</b>	<b>12</b>

# 1. Functional Description

The ISL29501-CS-EVKIT1Z is both a reference design and evaluation kit that provides a single platform to evaluate the features of the ISL29501. The ISL29501-CS-EVKIT1Z circuit board and supplied enclosure deliver maximum electrical and optical performance.

The system sends out light pulses through the emitter LED and receives returned light pulses that reflect off a target on the optics board. The difference in phase of the emitted signal and the return signal is converted to distance by the ISL29501 and is graphed in the evaluation software. The magnitude of the return signal is graphed as well. This and additional data are available in the chip registers, see *UG054, ISL29501 Evaluation Software Manual* for additional details.

## 1.1 Operating Features

The ISL29501-CS-EVKIT1Z evaluation kit is shown in [Figure 2](#) and [Figure 3](#). The hardware enable function is controlled by a software switch. A Power-Good (PG) LED indicates that the LDO is regulating properly when not lit.

### 1.1.1 External Power Supply

For high current/high duty cycle setups USB power may not be able to power the board.

### 1.1.2 External Microprocessor

For debugging of customer written software, it might be useful to connect the Cat Shark to a different microprocessor. All signals are available on the optics board connector J1. See the schematic for details. SCL and SDA are compatible with 1.8V microprocessors but unfortunately the support pins require 3V signaling.

### 1.1.3 System Calibration

Before meaningful measurements can be made the calibration registers in the chip need to be loaded. This can be done in two ways. The first is to load a profile that contains data into the GUI. This can be one of the Renesas provided profiles or one that was saved previously by the user. See *UG054, "SL29501 Evaluation Software Manual* for further details. The second is to calibrate the board directly.

### 1.1.4 Calibrating Cat Shark

There are three separate standard calibrations that need to be executed to calibrate the system. These are magnitude, crosstalk, and distance calibrations.

#### 1.1.4.1 Magnitude Calibration

Magnitude calibration is done after the emitter current and duty cycle settings are programmed. It is a dark (no light) calibration that takes less than 1s to run. Run this calibration from the GUI.

#### 1.1.4.2 Crosstalk Calibration

Crosstalk is defined as a signal that reaches the ISL29501 chip directly without bouncing off the target. This can be electrical or optical. At close range and large return signal values, crosstalk has a minor impact on distance measurements. At the far end of the distance range, the crosstalk might exceed the signal, adding error to measurements.

For this calibration, the user makes a distance measurement with the return signal blocked from reaching the photodiode. This can be done in two ways. The first is to cover the emitter or photodiode optically preventing any of the emitted signals from reaching the photodiode. The second is to point the board toward infinity so there is no return signal. **Note:** Care must be taken because small amounts of signal is returned by objects up to 4 meters away. The emitting angle of the light is  $\pm 3^\circ$  so you must ensure that there are no objects within this cone when doing this calibration.

Because the chip sees none of the emitted signal, anything received is crosstalk. Run this calibration from the GUI after running Magnitude calibration.

### 1.1.4.3 Distance Calibration

Variation in delay of emitters, photodiodes, and the ISL29501 change the signal path delay. To compensate for this, a reference point at a known distance needs to be established. This reference is calculated during distance calibration. The process involves making a distance measurement at a known distance. While it is not critical it is best to use a reference distance about 25% of the intended range. The GUI writes the correct registers that establish the reference distance inside the chip.

It is important that there are no objects inside the  $\pm 3^\circ$  emitting angle other than the target.

When these calibration registers are written, all succeeding distances have this measured value subtracted from the real-time value. Run this calibration from the GUI after running crosstalk calibration. See *UG054, ISL29501 Evaluation Software Manual* for details on how to run the calibrations in the GUI.

## 1.2 Operating Range

The controller circuit board contains an LDO to convert the input voltage to the ISL29501 operating voltage range, 2.7V to 3.3V. By default, the controller board is configured for USB power. The LDO resistors are rationed to create a 3.0V power rail. All other set-up conditions can be configured through the chip registers and evaluation software.

## 1.3 Quick Start Guide

To start making distance measurements follow these simple steps.

1. The board set comes assembled with the optics board connected to the controller board with an 8-pin flex cable. This cable should be as short as possible to minimize voltage drops.
2. Plug the USB cable into the controller board design and the PC.
3. Point the emitter toward the desired target.
4. Double click **TOF.exe** to start the GUI.
5. From the GUI click on **File** → **Load Profile** → **filename** to load safe initial register settings and calibration data.
6. Click either **Start** or **Step** to begin making distance measurements.

## 1.4 Changing Settings

When the board is running and making measurements, the user may want to change settings. The user has the ability to change any of the chip registers with the evaluation software, see *UG054, ISL29501 Evaluation Software Manual* for details. **Important:** If the pulse duty cycle or the emitter current is changed, the user must redo the standard calibrations. This process is described in the sections under [Calibrating Cat Shark](#).

## 1.5 Temperature Compensation

The ISL29501 has a temperature compensation built into the chip. This is an advanced calibration, which involves collecting temperature vs distance data and programming the compensation registers. Initially, Renesas generates these coefficients from customer collected data. The process for collecting data is described in *AN1967, ISL29501 Temperature and Ambient Light Data Collection*.

Renesas strongly recommends that customers evaluate these parameters as a last step in their evaluation. To avoid temperature effects low integration times,  $\text{reg } 0x10 < 0x06$  should be used.

## 2. Board Design



Figure 2. ISL29501-CS1Z Top

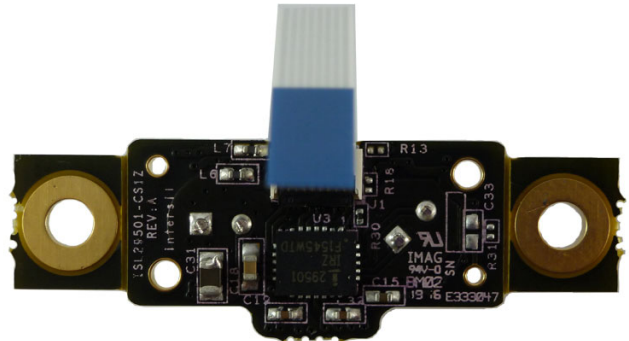

Figure 3. ISL29501-CS1Z Bottom.

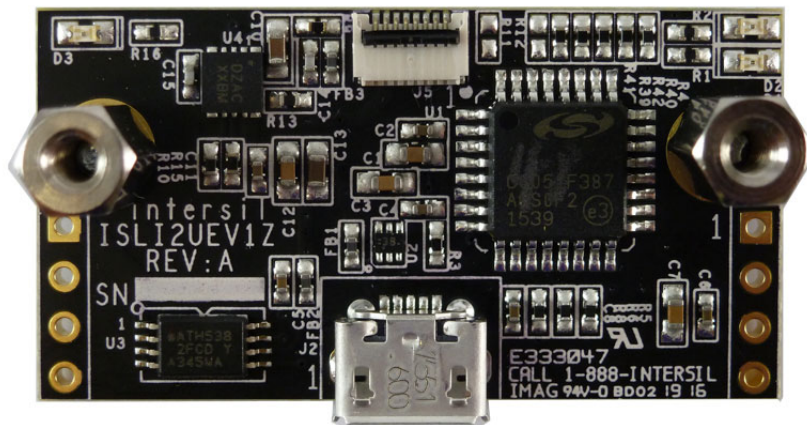

Figure 4. ISLI2UEV1Z

### 2.1 Layout Guidelines

The ISL29501-CS-EVKIT1Z PCB layout has been optimized for electrical and thermal performance. Care needs to be placed in decoupling circuits and noise isolation. Cat Shark follows good design techniques but additional suggestions are available in *AN1917, ISL29501 Layout Design Guide* (see [ISL29501-CS1Z PCB Layers](#) and [ISLI2UEV1Z PCB Layers](#)).

**Note:** Visible on the bottom side of the board are the emitter LED and photodiode. Each is surrounded by a brass tube. These tubes are grounded and serve as terminators for any electric fields. They prevent crosstalk from the emitter to the photodiode.



2.2.2 ISL29501-CS1Z Optics Board

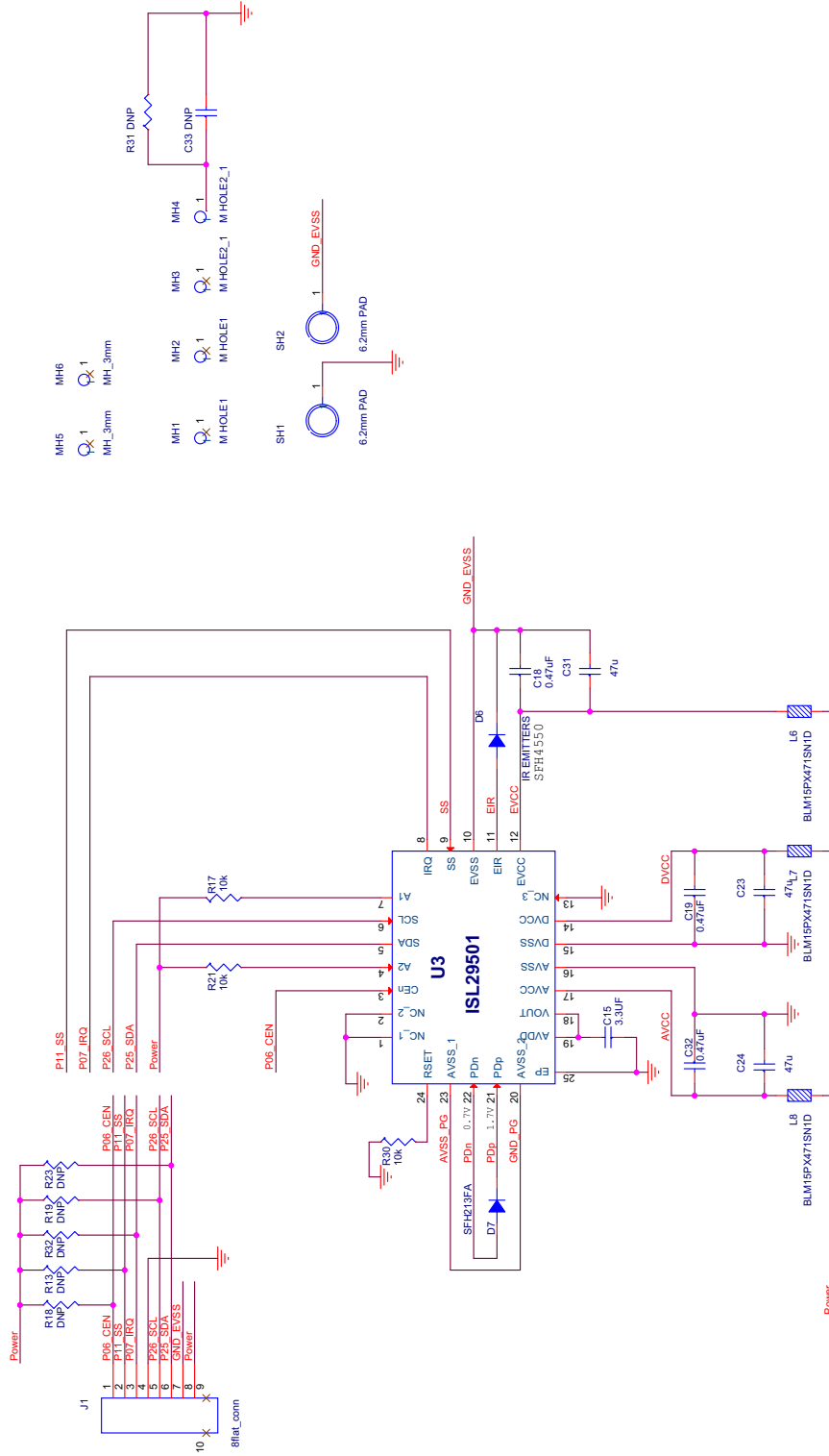

NOTE: DNP is DO NOT POPULATE

Figure 6. ISL29501-CS1Z Schematic - Optics Sheet

## 2.3 Bill of Materials

### 2.3.1 ISLI2UEV1Z

Qty	Reference Designator	Description	Manufacturer	Manufacturer Part
1		PWB-PCB, ISLI2UEV1Z, REVB, ROHS	IMAGINEERING INC	ISLI2UEV1ZREVBPCB
6	C2, C4, C5, C6, C8, C11	CAP, SMD, 0402, 0.1 $\mu$ F, 25V, 10%, X7R, ROHS	MURATA	GRM155R71E104KE14D
2	C14, C15	CAP, SMD, 0402, 100pF, 16V, 10%, NP0, ROHS	AVX	0402YA101KAT2A
4	C1, C3, C7, C12	CAP, SMD, 0603, 1.0 $\mu$ F, 10V, 10%, X7R, ROHS	AVX	0603ZC105KAT2A
2	C10, C13	CAP, SMD, 0603, 10 $\mu$ F, 16V, 10%, X5R, ROHS	MURATA	GRM188R61C106KAALD
1	J2	CONN-RECEPTACLE, USB-MICRO B, SMD, 5 CONTACT, R/A, ROHS	MOLEX	1050170001
1	J5	CONN-FFC/FPC FLAT FLEX, SMD, 8P, 0.5mm PITCH, R/A, ROHS	MOLEX	5034800800
1	D2	LED, SMD, 0603, GREEN CLEAR, 2V, 20mA, 574nm, 35mcd, ROHS	LITEON/VISHAY	LTST-C191KGKT
2	D1, D3	LED, SMD, 0603, RED CLEAR, 2V, 20mA, 631nm, 54mcd, ROHS	LITEON/VISHAY	LTST-C191KRKT
1	U3	IC-2-WIRE SERIAL EEPROM, 8P, TSSOP, 1MHz, 512KBIT, ROHS	ATMEL	AT24C512C-XHD
1	U1	IC-PROGRAMMED USB $\mu$ CONTROLLER, 32P, LQFP, 8-BIT, 48MIPS, ROHS	SILICON LABORATORIES	C8051F387-GQ
1	U4	IC-1A LDO ADJ. VOLT REGULATOR, 10P, DFN, 3x3, ROHS	Renesas	ISL80101AIRAJZ
1	U2	IC-TVS, 4-CHANNEL ESD SOLUTION, 6P, SON6, ROHS	TEXAS INSTRUMENTS	TPD4S012DRYR
1	R3	RES, SMD, 0402, 100 $\Omega$ , 1/16W, 1%, TF, ROHS	VENKEL	CR0402-16W-1000FT
5	R4, R5, R6, R7, R8	RES, SMD, 0402, 1k, 1/16W, 1%, TF, ROHS	VENKEL	CR0402-16W-1001FT
5	R10, R39, R40, R41, R42	RES, SMD, 0402, 10k, 1/16W, 1%, TF, ROHS	PANASONIC	ERJ-2RKF1002X
1	R15	RES, SMD, 0402, 24.9k, 1/16W, 1%, TF, ROHS	PANASONIC	ERJ-2RKF2492
4	R1, R2, R9, R16	RES, SMD, 0402, 2.61k, 1/16W, 1%, TF, ROHS	VENKEL	CR0402-16W-2611FT



Qty	Reference Designator	Description	Manufacturer	Manufacturer Part
1	R13	RES, SMD, 0402, 499Ω, 1/16W, 1%, TF, ROHS	VENKEL	CR0402-16W-4990FT
3	FB1, FB2, FB3	FERRITE BEAD, 1 LINE SIGNAL, SMD, 0402, 470Ω at 100MHz, 200mA, ROHS	MURATA	BLM15BD471SN1D
0	J1, J4, R11, R12	DO NOT POPULATE OR PURCHASE		
1	AFFIX TO BACK OF PCB	LABEL-DATE CODE_LINE 1: YRWK/REV#, LINE 2: BOM NAME	Renesas	LABEL-DATE CODE

### 2.3.2 ISL29501-CS1Z Optics Board

Qty	Reference Designator	Description	Manufacturer	Manufacturer Part
1		PWB-PCB, ISL29501-CS1Z, REVA, ROHS	IMAGINEERING INC	ISL29501-CS1ZREVAPCB
1	C15	CAP, SMD, 0402, 3.3μF, 4V, 20%, X5R, ROHS	TAIYO YUDEN	AMK105BJ335MV-F
2	C19, C32	CAP, SMD, 0402, 0.47μF, 25V, 10%, X5R, ROHS	TDK	C1005X5R1E474K050BB
1	C18	CAP, SMD, 0603, 0.47μF, 25V, 10%, X7R, ROHS	MURATA	GRM188R71E474KA12D
3	C23, C24, C31	CAP, SMD, 0805, 47μF, 10V, 20%, X5R, ROHS	TDK	C2012X5R1A476M125AC
1	J1	CONN-FFC/FPC FLAT FLEX, SMD, 8P, 0.5mmPITCH, R/A, ROHS	MOLEX	5034800800
1	D6	LED-EMITTER IR, TH, T1 3/4, 1.5V, 100mA, 850nm, ROHS	OSRAM	SFH4550
1	U3	IC-TOF SIGNAL PROCESSOR, 24P, QFN, ROHS	Renesas	ISL29501IRZ-T7
3	R17, R21, R30	RES, SMD, 0201, 10k, 1/20W, 1%, TF, ROHS	PANASONIC	ERJ-1GEF1002C
3	L6, L7, L8	FERRITE BEAD, 1 LINE SIGNAL, SMD, 0402, 470Ω at 100MHz, 200mA, ROHS	MURATA	BLM15BD471SN1D
2	SH1, SH2 *Surrounds D6, D7.	TUBE-BRASS, Alloy#260/270, 0.25OD, 0238ID, 0.394LENGTH, ROHS	K&S Precision Metals	CATSHARK-BRASSTUBE
0	C33	DO NOT POPULATE OR PURCHASE		
0	R13, R18, R19, R23, R31, R32	DO NOT POPULATE OR PURCHASE		
1	AFFIX TO BACK OF PCB	LABEL-DATE CODE_LINE 1: YRWK/REV#, LINE 2: BOM NAME	Renesas	LABEL-DATE CODE
1	D7	IC-PHOTODIODE, RADIAL, 2P, 5mm, 50V, 900nm, 1nA, ROHS	OSRAM	SFH213-FA

## 2.3.3 ISL29501-CS-EVKIT1Z Cat Shark Assembly

Qty	Reference Designator	Description	Manufacturer	Manufacturer Part
1	SEE ASSEMBLY INSTRUCTIONS	CABLE, FLAT-FLEX, 8CONDUCT, 0.5mmPITCH, 30mmLENGTH, ROHS	MOLEX	152660073
1	BAG & SHIP W/BOARD	CABLE-USB TYPE A MALE to TYPE MICRO-B MALE, 3FT, ROHS	QUALTEK ELECTRONICS	3025010-03
1	SEE DOCUMENT #1	PWB-FG, ISL29501-CS1Z, ROHS	Renesas	ISL29501-CS1ZFG
1	SEE DOCUMENT #1	PWB-FG, ISLI2UEV1Z, ROHS	Renesas	ISLI2UEV1ZFG
4	SEE ASSEMBLY INSTRUCTIONS	SCREW, M2.5, 4mm, METRIC, PANHEAD, SLOTTED, STEEL, ROHS	KEYSTONE	29300
2	SEE ASSEMBLY INSTRUCTIONS	STANDOFF, M2.5, 8mm, METRIC, F/F, HEX, THREAD, BRASS, ROHS	ASSMANN ELECTRONICS INC	V6516B
1	Place assy in bag	BAG, STATIC BUBBLE, 4X5, SELF-SEAL, ROHS	ULINE	S-6660
1	Face boards top to top. Insert screws from bottom of boards and attach standoffs between board tops. Connect cable between J1 on ISL29501-CS1Z and J5 on ISLI2UEV1Z. Lift retainers on connectors, insert cable, and lower retainers to secure cable.	Instructions for assembly.	Renesas	ASSEMBLY INSTRUCTIONS
1	FINAL ASSEMBLY DWG	See attached document for manual or visual instruction	Renesas	DOCUMENT #1

## 2.4 Board Layout

### 2.4.1 ISL29501-CS1Z PCB Layers

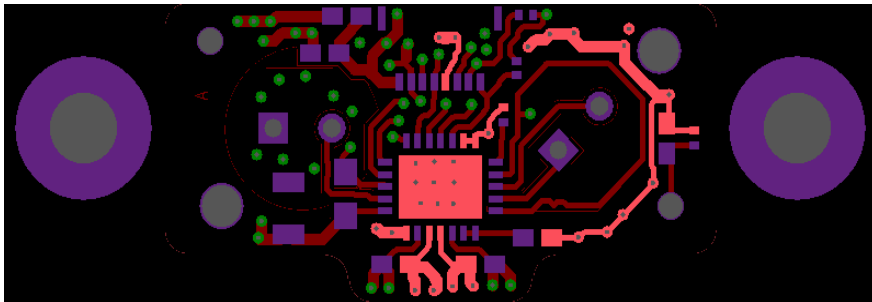

Figure 7. Layer 1



Figure 8. Layer 2

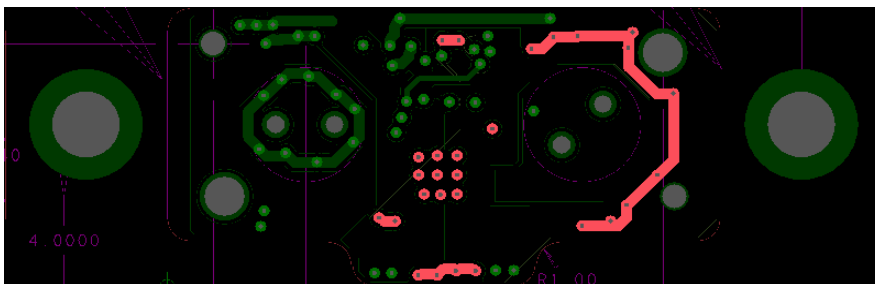

Figure 9. Layer 3

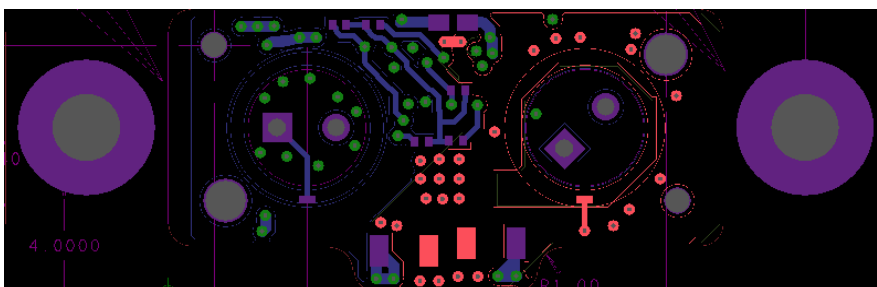

Figure 10. Layer 4

### 2.4.2 ISLI2UEV1Z PCB Layers

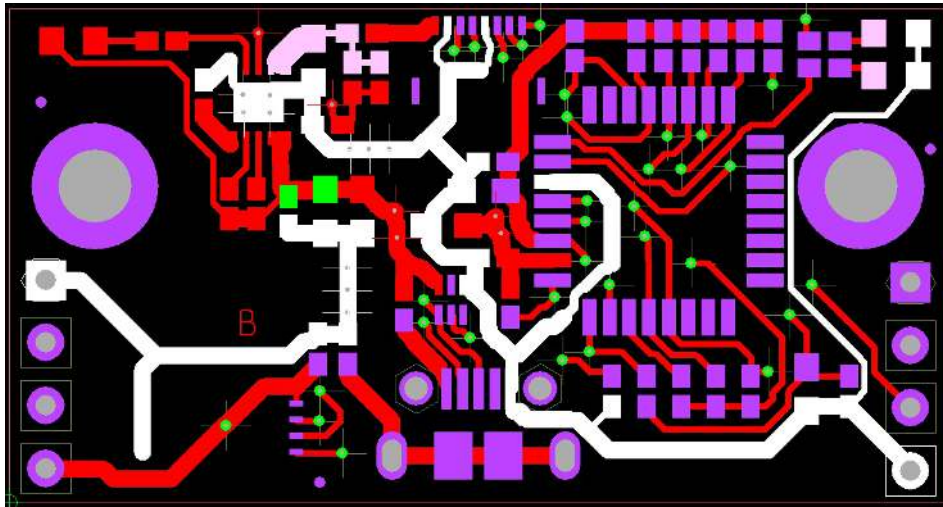

Figure 11. Layer 1 (Viewed from Top)

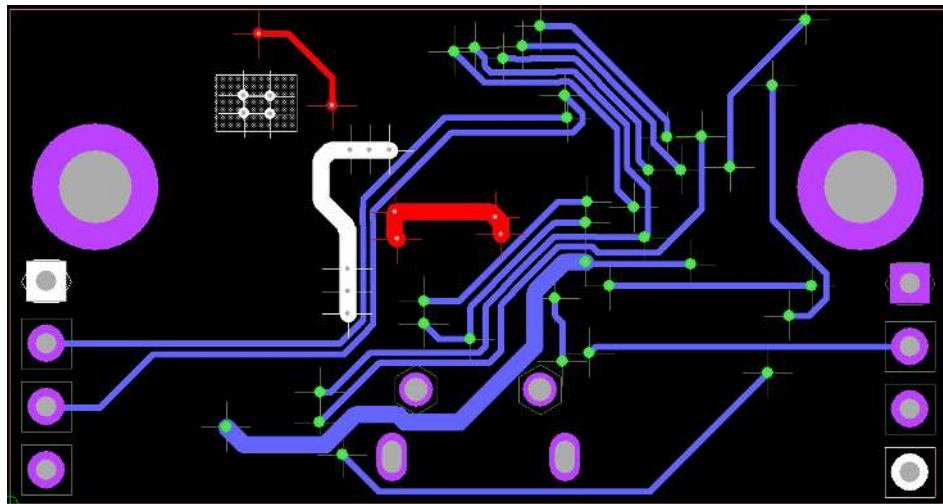

Figure 12. Layer 2 (Viewed from Top)

## 3. Ordering Information

Part Number	Description
ISL29501-CS-EVKIT1Z	ISL29501 Cat Shark evaluation kit

## 4. Revision History

Revision	Date	Description
1.00	Apr 5, 2022	Applied new template.
0.00	Jun 27, 2016	Initial release

## IMPORTANT NOTICE AND DISCLAIMER

RENESAS ELECTRONICS CORPORATION AND ITS SUBSIDIARIES (“RENESAS”) PROVIDES TECHNICAL SPECIFICATIONS AND RELIABILITY DATA (INCLUDING DATASHEETS), DESIGN RESOURCES (INCLUDING REFERENCE DESIGNS), APPLICATION OR OTHER DESIGN ADVICE, WEB TOOLS, SAFETY INFORMATION, AND OTHER RESOURCES “AS IS” AND WITH ALL FAULTS, AND DISCLAIMS ALL WARRANTIES, EXPRESS OR IMPLIED, INCLUDING, WITHOUT LIMITATION, ANY IMPLIED WARRANTIES OF MERCHANTABILITY, FITNESS FOR A PARTICULAR PURPOSE, OR NON-INFRINGEMENT OF THIRD PARTY INTELLECTUAL PROPERTY RIGHTS.

These resources are intended for developers skilled in the art designing with Renesas products. You are solely responsible for (1) selecting the appropriate products for your application, (2) designing, validating, and testing your application, and (3) ensuring your application meets applicable standards, and any other safety, security, or other requirements. These resources are subject to change without notice. Renesas grants you permission to use these resources only for development of an application that uses Renesas products. Other reproduction or use of these resources is strictly prohibited. No license is granted to any other Renesas intellectual property or to any third party intellectual property. Renesas disclaims responsibility for, and you will fully indemnify Renesas and its representatives against, any claims, damages, costs, losses, or liabilities arising out of your use of these resources. Renesas' products are provided only subject to Renesas' Terms and Conditions of Sale or other applicable terms agreed to in writing. No use of any Renesas resources expands or otherwise alters any applicable warranties or warranty disclaimers for these products.

(Rev.1.0 Mar 2020)

### Corporate Headquarters

TOYOSU FORESIA, 3-2-24 Toyosu,  
Koto-ku, Tokyo 135-0061, Japan  
[www.renesas.com](http://www.renesas.com)

### Contact Information

For further information on a product, technology, the most up-to-date version of a document, or your nearest sales office, please visit:  
[www.renesas.com/contact/](http://www.renesas.com/contact/)

### Trademarks

Renesas and the Renesas logo are trademarks of Renesas Electronics Corporation. All trademarks and registered trademarks are the property of their respective owners.