

REVISIONS					
P	LTR	DESCRIPTION	DATE	DWN	APVD
	A	NEW DRAWING	07OCT2017	GK	DB
	A1	UL TABLE UPDATED	06JUN2018	GK	DB

### LABEL AND LINER DESIGN

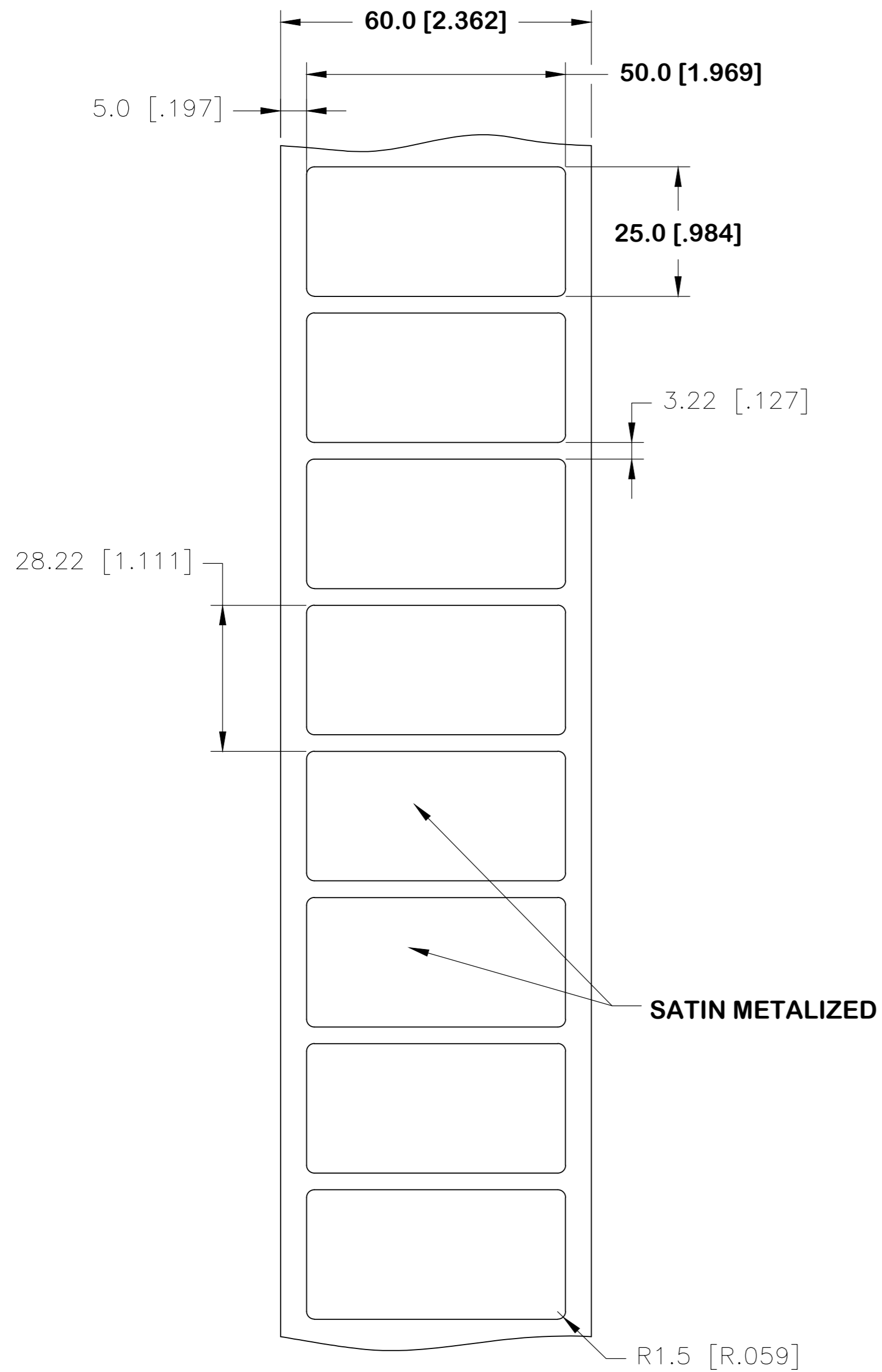

### PRESENTATION

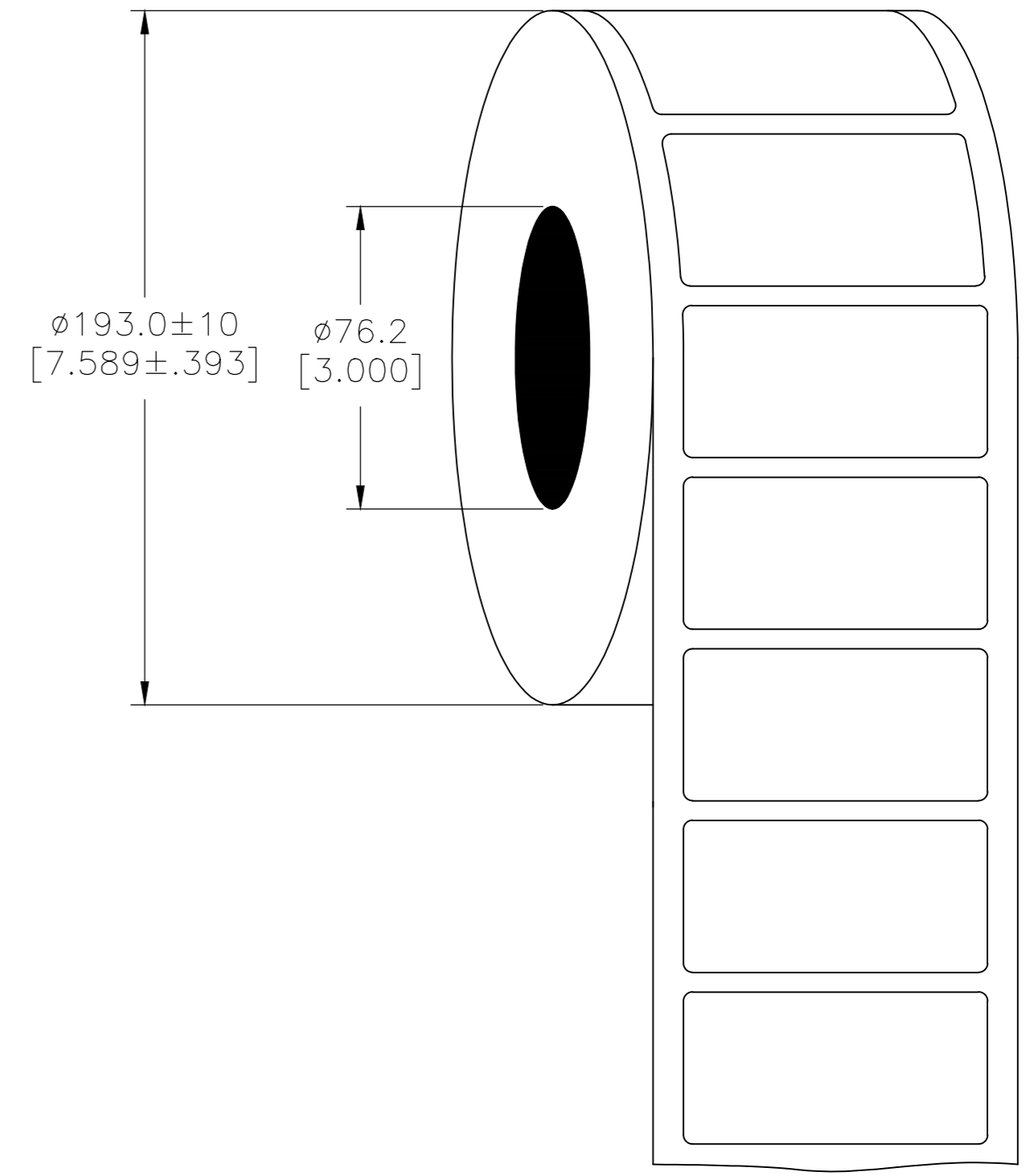

**OUTSIDE WOUND  
 LABEL ACROSS: 1  
 PER ROLL QTY: 1000**

All dimensions in mm [Inch]

**TE PN: 2322593-1**

UL-MARKING AND LABELLING SYSTEMS	
PGJ12 - Printing Materials - Component (UL 969)	
PGJ18 - Printing Materials Certified for Canada - Component (CSA C22.2 No. 0.15)	
File: MH17292	Product design: <b>PL-8A</b> Ribbon: TTB-XXXSC/YYYYAQ529

TOLERANCES mm [INCH]	
LABEL HEIGHT:	$\pm 0.3$ [.012]
LABEL WIDTH:	$\pm 0.3$ [.012]
WEB WIDTH:	$\pm 0.5$ [.020]
VERTICAL REPEAT:	$\pm 0.5$ [.020]*
HORIZONTAL REPEAT:	$\pm 0.5$ [.020]*
LABEL POSITIONING:	$\pm 0.5$ [.020]*
LEFT MARGIN:	$\pm 0.5$ [.020]
QUANTITY:	-0 % +2 %
*NON ACCUMULATING	

MATERIAL	POLYESTER SATIN METALIZED	
ADHESIVE TYPE	ACRYLIC PE FOAM	
LINEAR	BROWN KRAFT	
DWN	GOPALAKRISHNA HV	07OCT2017
CHK	D.BURGAT	07OCT2017
APVD	D.BURGAT	07OCT2017
PRODUCT SPEC	TTDS-245	
APPLICATION SPEC	-	
WEIGHT	0.589 <sub>g</sub>	
CUSTOMER DRAWING	SCALE NTS SHEET 1 of 1 REV A1	