

TPS61252 Evaluation Module

This user's guide describes the characteristics, operation, and use of the TPS61252 evaluation module (EVM). This EVM contains the Texas Instruments 3.25 MHz, up to 6.5 V, step-up DC-DC converter TPS61252 with an adjustable input current limit. The user's guide includes EVM specifications, recommended test setup, the schematic diagram, bill of materials, the board layout, and test data.

CAUTION

Please be aware that the input current is limited to 500 mA on this EVM. For maximum output current operation remove R3 and connect ILIM to VIN.

Contents

1	Introduction	2
	1.1 Requirements	2
	1.2 Applications	2
	1.3 Features	2
2	TPS61252 EVM Electrical Performance Specifications	3
3	TPS61252 EVM Schematic	3
4	Connector and Test Point Descriptions	4
	4.1 Input Connectors	4
	4.2 Output Connectors	4
	4.3 Other Connectors	4
	4.4 Jumpers	4
5	TPS61252 EVM Test Data	5
	5.1 Efficiency	5
	5.2 Line and Load Regulation	5
	5.3 Output Voltage Ripple	6
	5.4 Control Loop Bode Diagram	6
6	TPS61252 EVM Assembly Drawings and Layout	7
7	List of Materials	8

List of Figures

1	TPS61252 EVM Schematic.....	3
2	TPS61252 EVM Efficiency vs Load Current.....	5
3	TPS61252 EVM Load Transient Response Continuous Conduction Mode.....	5
4	TPS61252 EVM Load Transient Response with Mode Change, Snooze Mode to Pulse Frequency Mode.....	5
5	TPS61252 EVM Line Transient Response	5
6	TPS61252 EVM Output Voltage Ripple at No Load.....	6
7	TPS61252 EVM Output Voltage Ripple at Load Limit	6
8	TPS61252 EVM Output Voltage Ripple at Overload	6
9	TPS61252 EVM Gain and Phase vs. Frequency	6
10	TPS61252 EVM Component Placement (Viewed from Top).....	7

11	TPS61252 EVM Top Copper (Viewed from Top)	7
12	TPS61252 EVM Bottom Copper (Viewed from Bottom)	8

List of Tables

1	TPS61252 EVM Electrical and Performance Specifications	3
2	TPS61252 EVM Bill of Materials	8

1 Introduction

The TPS61252 device provides a power supply solution for products powered by either a three-cell alkaline, NiCd or NiMH battery, or a one-cell Li-Ion or Li-polymer battery. The wide input voltage range is ideal to power portable applications like mobile phones or computer peripherals. The device has a resistor programmable (RILIM) input current limit and is suitable for a wide variety of applications.

1.1 Requirements

The TPS61252 EVM is designed to operate over the full input voltage range and produces an output voltage of 5.0 V. The output voltage can be adjusted by changing the feedback resistor divider network.

In order to operate this EVM, only a DC power supply capable of delivering between 2.3 V and 6.0 V at up to 500 mA is necessary.

1.2 Applications

- USB Host Supplies from a Single Li-Ion Battery
- Current Limited Applications
- Li-Ion Applications
- Audio Applications
- RF-PA Buffers

1.3 Features

- Resistor Programmable Input Current Limit
 - $\pm 20\%$ Current Accuracy at 500 mA over Full Temperature Range
 - Programmable from 100 mA up to 1500 mA
- Up to 92% Efficiency
- V_{IN} Range from 2.3 V to 6.0 V
- Power Good Indicates the Appropriate Output Voltage Level
- Adjustable Output Voltage up to 6.5 V
- 100% Duty-Cycle Mode When $V_{IN} > V_{OUT}$
- Load Disconnect and Reverse Current Protection
- Double-sided, two-active-layer PCB with all components on top side
- Active converter area of approximately 60 mm²

2 TPS61252 EVM Electrical Performance Specifications

Table 1. TPS61252 EVM Electrical and Performance Specifications

Parameter	Notes & Conditions	Min	Typ	Max	Unit		
Input Characteristics							
V_{IN}	Input Voltage	2.3		6.0	V		
I_{IN}	Average Input Current	400	500	600	mA		
	No Load Input Current			1	mA		
V_{IN_UVLO}	Input UVLO	Falling	2.0	2.1	V		
Output Characteristics							
V_{OUT}	Output Voltage	$V_{IN} = 3.6\text{ V}, I_{OUT} = 300\text{ mA}$		4.9	4.99	5.1	V
	Line Regulation	$V_{IN} = 2.3\text{ V to }6.0\text{ V}$		0.5%			
	Load Regulation	$I_{OUT} = 0\text{ mA to }300\text{ mA}$		0.5%			
$V_{OUT\text{Ripple}}$	Output Voltage Ripple	$V_{IN} = 3.6\text{ V}, I_{OUT} = 330\text{ mA}$		50		mVpp	
I_{OUT}	Output Current	$V_{IN} = 3.6\text{ V}$		330		mA	
Systems Characteristics							
f	Switching Frequency			3.25		MHz	
η_{pk}	Peak Efficiency	$V_{IN} = 3.6\text{ V}$		92%			
η	Full Load Efficiency	$V_{IN} = 3.6\text{ V}, I_{OUT} = 330\text{ mA}$		90%			

3 TPS61252 EVM Schematic

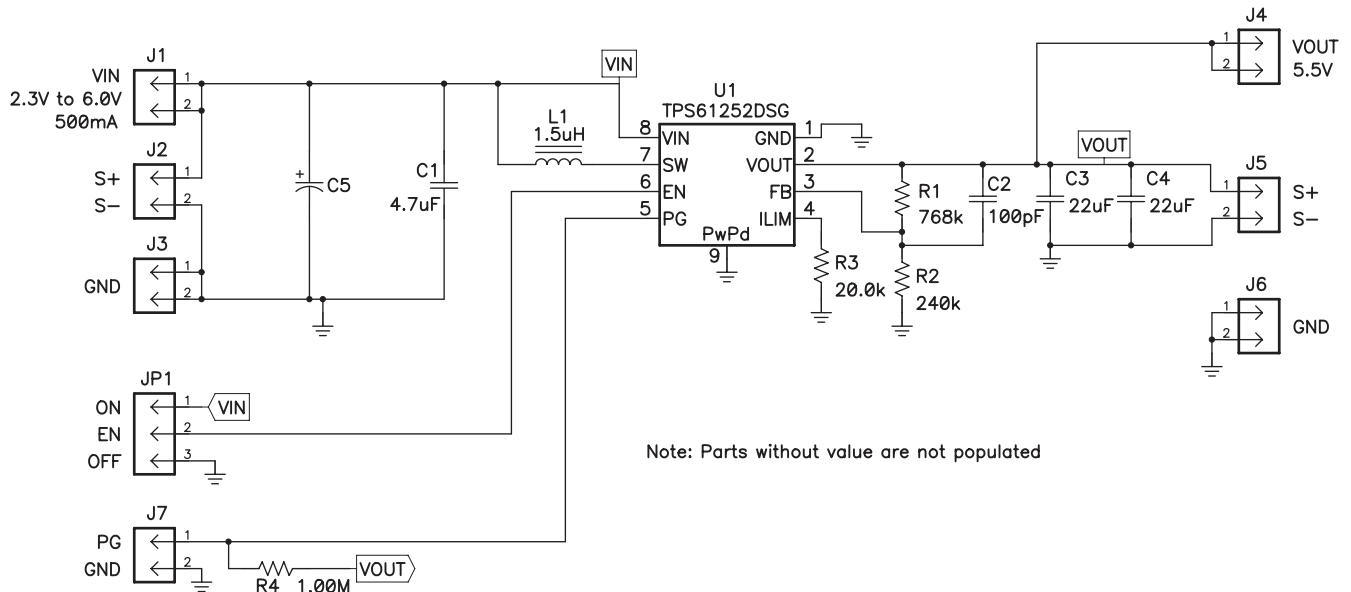

For Reference Only, See [Table 2](#) for Specific Values

Figure 1. TPS61252 EVM Schematic

4 Connector and Test Point Descriptions

4.1 Input Connectors

4.1.1 J1 – VIN

This header is the positive connection to the input power supply. The power supply must be connected between these pins and J3 (GND). Twist the leads to the input supply and keep them as short as possible. The input voltage has to be between 2.3 V and 6.0 V.

4.1.2 J2 – Input Sense Connector

This header is intended to measure the input voltage directly on the input capacitor. Therefore, a 4-wire power and sense supply can be connected. Twist the leads to the sensing connector.

4.1.3 J3 –GND

This header is the return connection to the input power supply. Connect the power supply between these pins and J1 (VIN). Twist the leads to the input supply and keep them as short as possible. The input voltage must be between 2.3 V and 6.0 V.

4.2 Output Connectors

4.2.1 J4 – VOUT

This header is the positive connection of the output voltage. Connect the load between these pins and J6 (GND).

4.2.2 J5 – Output Sense Connector

This header is intended to measure the output voltage directly on the output capacitors.

4.2.3 J6 – GND

This header is the return connection of the output voltage. Connect the load between these pins and J4 (VOUT).

4.3 Other Connectors

4.3.1 J7 – Power Good Connector

The Power Good Output (PG) of the IC is an open-drain output and there is a 1 M Ω resistor connected between PG and VOUT. Pin 1 of this connector is connected to PG and Pin2 is connected to GND.

4.4 Jumpers

4.4.1 JP1 – Enable Jumper

Placing a jumper across pins EN and ON ties the EN pin to VIN, thereby enabling the device. Placing a jumper across pins EN and OFF ties the EN pin to GND, which disables the device.

5 TPS61252 EVM Test Data

Figure 5 through Figure 11 present typical performance curves for the TPS61252 EVM. Since actual performance data can be affected by measurement techniques and environmental variables, these curves are presented for reference and may differ from actual field measurements.

5.1 Efficiency

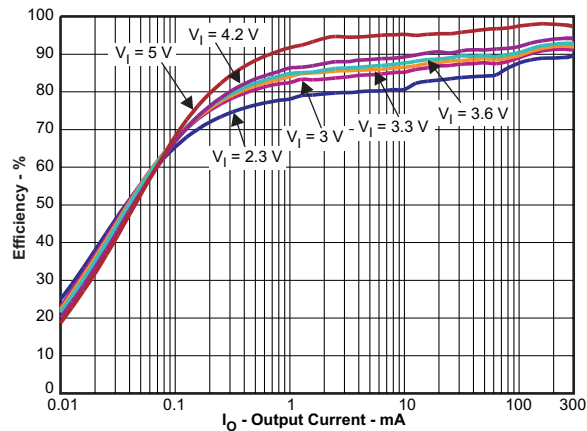

Figure 2. TPS61252 EVM Efficiency vs Load Current

5.2 Line and Load Regulation

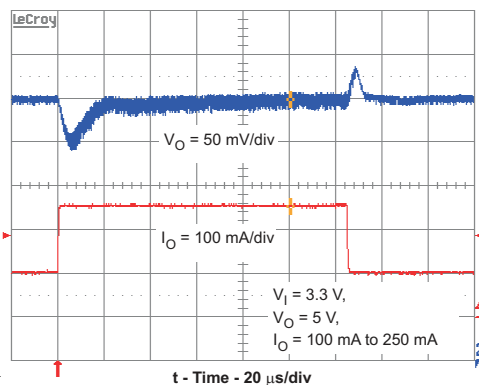

Figure 3. TPS61252 EVM Load Transient Response Continuous Conduction Mode

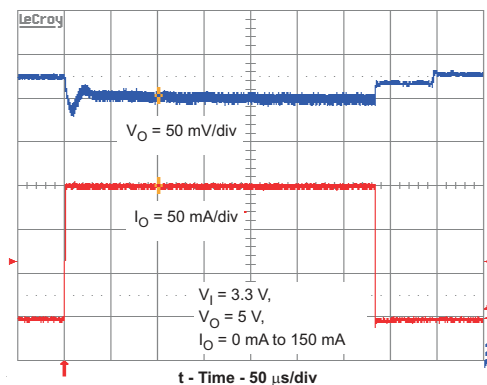

Figure 4. TPS61252 EVM Load Transient Response with Mode Change, Snooze Mode to Pulse Frequency Mode

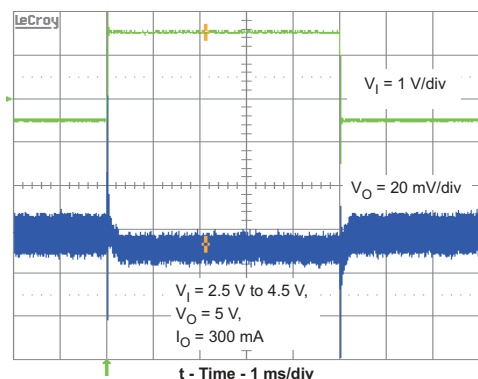

Figure 5. TPS61252 EVM Line Transient Response

5.3 Output Voltage Ripple

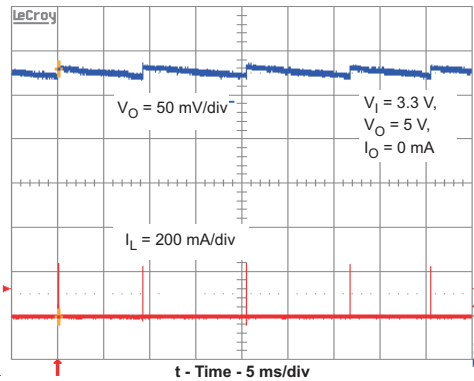

Figure 6. TPS61252 EVM Output Voltage Ripple at No Load

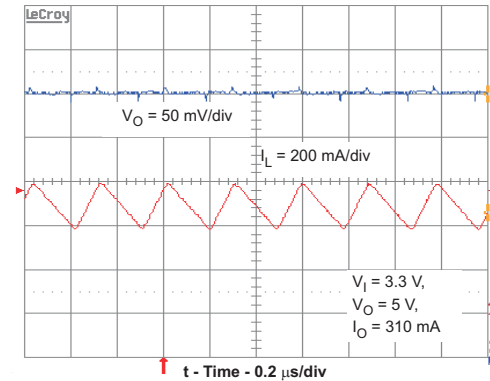

Figure 7. TPS61252 EVM Output Voltage Ripple at Load Limit

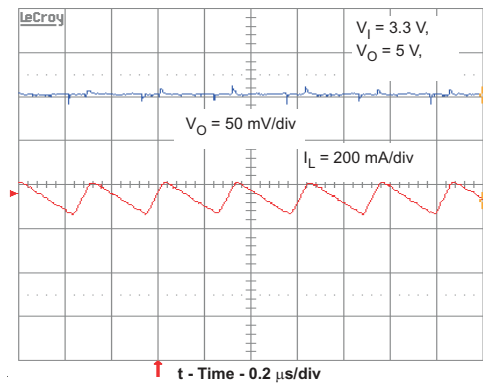

Figure 8. TPS61252 EVM Output Voltage Ripple at Overload

5.4 Control Loop Bode Diagram

The stability was measured with an input voltage of 3.3 V and an output current of 244 mA. The crossover frequency of 47 kHz and the phase margin of 42° correlate with the good load transient response of the part.

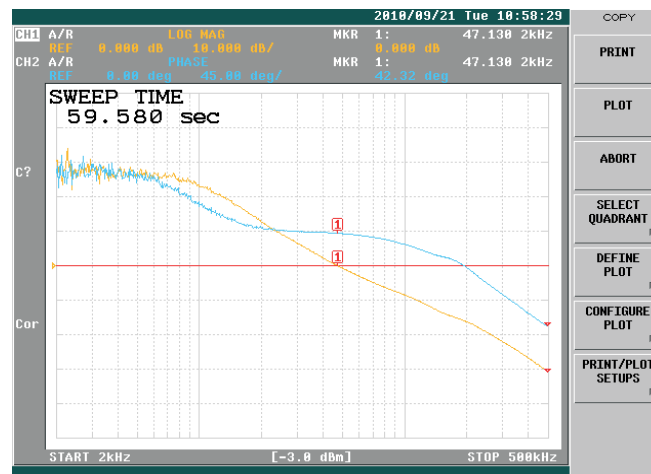

Figure 9. TPS61252 EVM Gain and Phase vs. Frequency

6 TPS61252 EVM Assembly Drawings and Layout

Figure 10 through Figure 12 show the design of the TPS61252 EVM printed circuit board. The EVM uses a 2-Layer, 1-oz copper-clad circuit board 61 mm x 51 mm with all components in a 7 mm x 11 mm active area on the top side. All active top and bottom layer traces allow easy viewing and probing for evaluating the TPS61252 control IC in a practical double-sided application. Moving components to both sides of the PCB, or using additional internal layers, can offer additional size reduction for space-constrained systems.

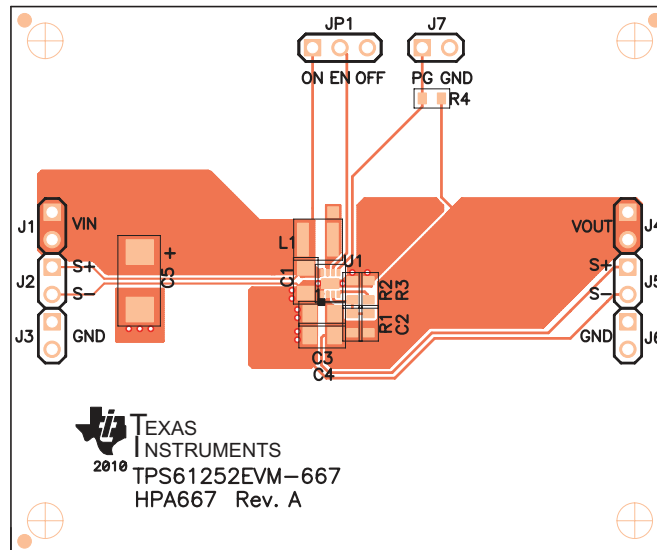

Figure 10. TPS61252 EVM Component Placement (Viewed from Top)

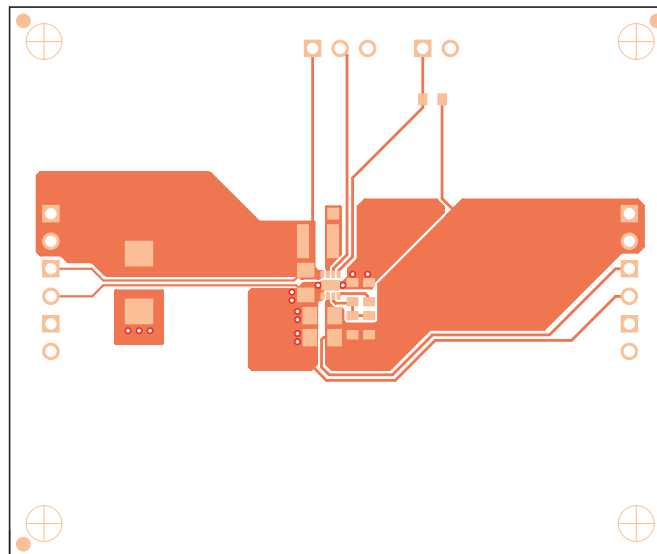

Figure 11. TPS61252 EVM Top Copper (Viewed from Top)

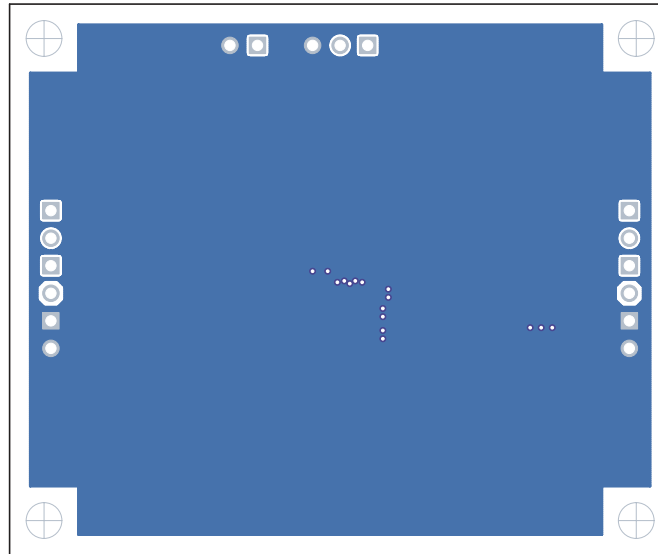

Figure 12. TPS61252 EVM Bottom Copper (Viewed from Bottom)

7 List of Materials

Table 2 lists the EVM components as configured according to the schematic shown in Figure 1.

Table 2. TPS61252 EVM Bill of Materials

Count	RefDes	Value	Description	Size	Part Number	MFR
1	C1	4.7 μ F	Capacitor, Ceramic, 10V, X7R, 10%	0805	GRM21BR71A475KA73	Murata
1	C2	100pF	Capacitor, Ceramic, 50V, X7R, 10%	0603	STD	STD
2	C3, C4	22 μ F	Capacitor, Ceramic, 6.3V, X5R, 20%	0805	GRM21BR61A226ME51	Murata
0	C5	open	Capacitor, Aluminum	6032 (C)	STD	STD
1	L1	1.5 μ H	Inductor, SMT, 2.2A, 72milliohm	0.118 X 0.118 inch	XFL3012-152ME	Coilcraft
1	R1	768k	Resistor, Chip, 1/16W, 1%	0603	STD	STD
1	R2	240k	Resistor, Chip, 1/16W, 1%	0603	STD	STD
1	R3	20.0k	Resistor, Chip, 1/16W, 1%	0603	STD	STD
1	R4	1.00M	Resistor, Chip, 1/16W, 1%	0603	STD	STD
1	U1	TPS61252DSG	IC, High Frequency Step-Up Converter, Variable Vout	QFN	TPS61252DSG	TI

Evaluation Board/Kit Important Notice

Texas Instruments (TI) provides the enclosed product(s) under the following conditions:

This evaluation board/kit is intended for use for **ENGINEERING DEVELOPMENT, DEMONSTRATION, OR EVALUATION PURPOSES ONLY** and is not considered by TI to be a finished end-product fit for general consumer use. Persons handling the product(s) must have electronics training and observe good engineering practice standards. As such, the goods being provided are not intended to be complete in terms of required design-, marketing-, and/or manufacturing-related protective considerations, including product safety and environmental measures typically found in end products that incorporate such semiconductor components or circuit boards. This evaluation board/kit does not fall within the scope of the European Union directives regarding electromagnetic compatibility, restricted substances (RoHS), recycling (WEEE), FCC, CE or UL, and therefore may not meet the technical requirements of these directives or other related directives.

Should this evaluation board/kit not meet the specifications indicated in the User's Guide, the board/kit may be returned within 30 days from the date of delivery for a full refund. **THE FOREGOING WARRANTY IS THE EXCLUSIVE WARRANTY MADE BY SELLER TO BUYER AND IS IN LIEU OF ALL OTHER WARRANTIES, EXPRESSED, IMPLIED, OR STATUTORY, INCLUDING ANY WARRANTY OF MERCHANTABILITY OR FITNESS FOR ANY PARTICULAR PURPOSE.**

The user assumes all responsibility and liability for proper and safe handling of the goods. Further, the user indemnifies TI from all claims arising from the handling or use of the goods. Due to the open construction of the product, it is the user's responsibility to take any and all appropriate precautions with regard to electrostatic discharge.

EXCEPT TO THE EXTENT OF THE INDEMNITY SET FORTH ABOVE, NEITHER PARTY SHALL BE LIABLE TO THE OTHER FOR ANY INDIRECT, SPECIAL, INCIDENTAL, OR CONSEQUENTIAL DAMAGES.

TI currently deals with a variety of customers for products, and therefore our arrangement with the user **is not exclusive.**

TI assumes **no liability for applications assistance, customer product design, software performance, or infringement of patents or services described herein.**

Please read the User's Guide and, specifically, the Warnings and Restrictions notice in the User's Guide prior to handling the product. This notice contains important safety information about temperatures and voltages. For additional information on TI's environmental and/or safety programs, please contact the TI application engineer or visit www.ti.com/esh.

No license is granted under any patent right or other intellectual property right of TI covering or relating to any machine, process, or combination in which such TI products or services might be or are used.

FCC Warning

This evaluation board/kit is intended for use for **ENGINEERING DEVELOPMENT, DEMONSTRATION, OR EVALUATION PURPOSES ONLY** and is not considered by TI to be a finished end-product fit for general consumer use. It generates, uses, and can radiate radio frequency energy and has not been tested for compliance with the limits of computing devices pursuant to part 15 of FCC rules, which are designed to provide reasonable protection against radio frequency interference. Operation of this equipment in other environments may cause interference with radio communications, in which case the user at his own expense will be required to take whatever measures may be required to correct this interference.

EVM Warnings and Restrictions

It is important to operate this EVM within the input voltage range of 2.3 V to 6 V and the output voltage range of 3.0 V to 6.5 V .

Exceeding the specified input range may cause unexpected operation and/or irreversible damage to the EVM. If there are questions concerning the input range, please contact a TI field representative prior to connecting the input power.

Applying loads outside of the specified output range may result in unintended operation and/or possible permanent damage to the EVM. Please consult the EVM User's Guide prior to connecting any load to the EVM output. If there is uncertainty as to the load specification, please contact a TI field representative.

During normal operation, some circuit components may have case temperatures greater than 60° C. The EVM is designed to operate properly with certain components above 60° C as long as the input and output ranges are maintained. These components include but are not limited to linear regulators, switching transistors, pass transistors, and current sense resistors. These types of devices can be identified using the EVM schematic located in the EVM User's Guide. When placing measurement probes near these devices during operation, please be aware that these devices may be very warm to the touch.

Mailing Address: Texas Instruments, Post Office Box 655303, Dallas, Texas 75265
Copyright © 2010, Texas Instruments Incorporated

IMPORTANT NOTICE

Texas Instruments Incorporated and its subsidiaries (TI) reserve the right to make corrections, modifications, enhancements, improvements, and other changes to its products and services at any time and to discontinue any product or service without notice. Customers should obtain the latest relevant information before placing orders and should verify that such information is current and complete. All products are sold subject to TI's terms and conditions of sale supplied at the time of order acknowledgment.

TI warrants performance of its hardware products to the specifications applicable at the time of sale in accordance with TI's standard warranty. Testing and other quality control techniques are used to the extent TI deems necessary to support this warranty. Except where mandated by government requirements, testing of all parameters of each product is not necessarily performed.

TI assumes no liability for applications assistance or customer product design. Customers are responsible for their products and applications using TI components. To minimize the risks associated with customer products and applications, customers should provide adequate design and operating safeguards.

TI does not warrant or represent that any license, either express or implied, is granted under any TI patent right, copyright, mask work right, or other TI intellectual property right relating to any combination, machine, or process in which TI products or services are used. Information published by TI regarding third-party products or services does not constitute a license from TI to use such products or services or a warranty or endorsement thereof. Use of such information may require a license from a third party under the patents or other intellectual property of the third party, or a license from TI under the patents or other intellectual property of TI.

Reproduction of TI information in TI data books or data sheets is permissible only if reproduction is without alteration and is accompanied by all associated warranties, conditions, limitations, and notices. Reproduction of this information with alteration is an unfair and deceptive business practice. TI is not responsible or liable for such altered documentation. Information of third parties may be subject to additional restrictions.

Resale of TI products or services with statements different from or beyond the parameters stated by TI for that product or service voids all express and any implied warranties for the associated TI product or service and is an unfair and deceptive business practice. TI is not responsible or liable for any such statements.

TI products are not authorized for use in safety-critical applications (such as life support) where a failure of the TI product would reasonably be expected to cause severe personal injury or death, unless officers of the parties have executed an agreement specifically governing such use. Buyers represent that they have all necessary expertise in the safety and regulatory ramifications of their applications, and acknowledge and agree that they are solely responsible for all legal, regulatory and safety-related requirements concerning their products and any use of TI products in such safety-critical applications, notwithstanding any applications-related information or support that may be provided by TI. Further, Buyers must fully indemnify TI and its representatives against any damages arising out of the use of TI products in such safety-critical applications.

TI products are neither designed nor intended for use in military/aerospace applications or environments unless the TI products are specifically designated by TI as military-grade or "enhanced plastic." Only products designated by TI as military-grade meet military specifications. Buyers acknowledge and agree that any such use of TI products which TI has not designated as military-grade is solely at the Buyer's risk, and that they are solely responsible for compliance with all legal and regulatory requirements in connection with such use.

TI products are neither designed nor intended for use in automotive applications or environments unless the specific TI products are designated by TI as compliant with ISO/TS 16949 requirements. Buyers acknowledge and agree that, if they use any non-designated products in automotive applications, TI will not be responsible for any failure to meet such requirements.

Following are URLs where you can obtain information on other Texas Instruments products and application solutions:

Products		Applications	
Amplifiers	amplifier.ti.com	Audio	www.ti.com/audio
Data Converters	dataconverter.ti.com	Automotive	www.ti.com/automotive
DLP® Products	www.dlp.com	Communications and Telecom	www.ti.com/communications
DSP	dsp.ti.com	Computers and Peripherals	www.ti.com/computers
Clocks and Timers	www.ti.com/clocks	Consumer Electronics	www.ti.com/consumer-apps
Interface	interface.ti.com	Energy	www.ti.com/energy
Logic	logic.ti.com	Industrial	www.ti.com/industrial
Power Mgmt	power.ti.com	Medical	www.ti.com/medical
Microcontrollers	microcontroller.ti.com	Security	www.ti.com/security
RFID	www.ti-rfid.com	Space, Avionics & Defense	www.ti.com/space-avionics-defense
RF/IF and ZigBee® Solutions	www.ti.com/lprf	Video and Imaging	www.ti.com/video
		Wireless	www.ti.com/wireless-apps

Mailing Address: Texas Instruments, Post Office Box 655303, Dallas, Texas 75265
Copyright © 2010, Texas Instruments Incorporated