

REVISIONS			
REV.	DESCRIPTION	DATE	APPROVED
A00	INITIAL RELEASE	05/30/12	D.N.

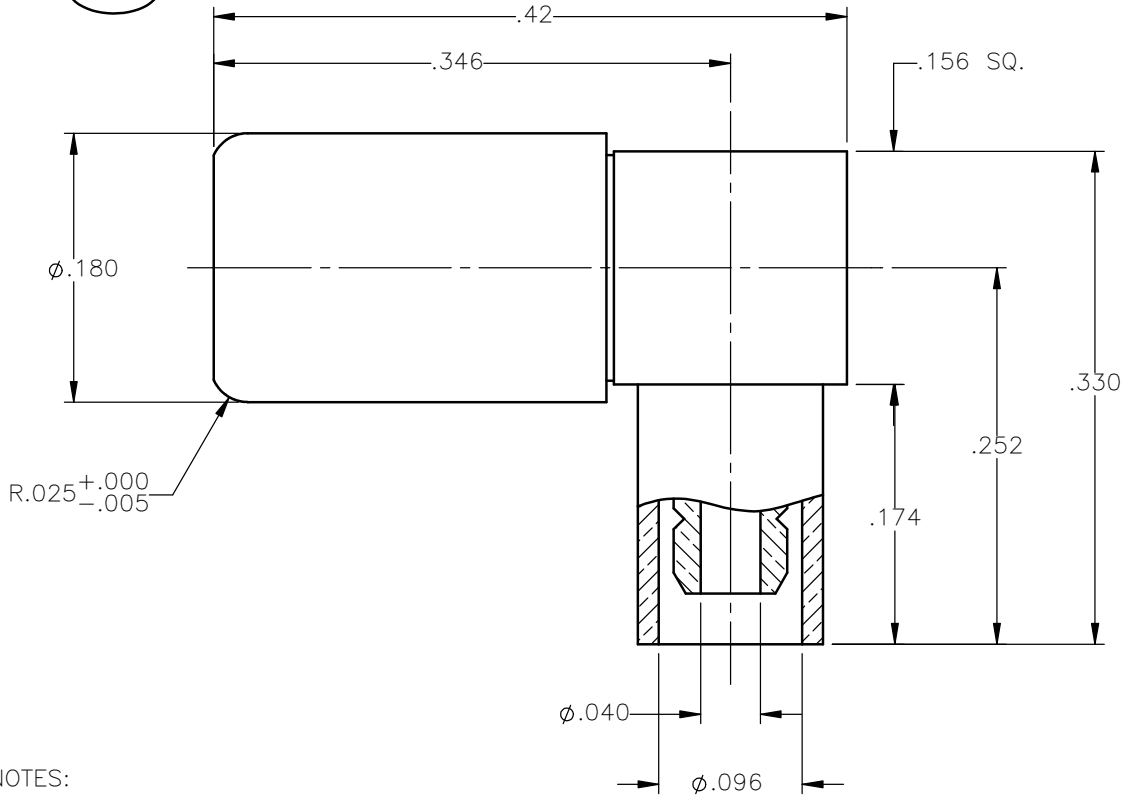

NOTES:



MATERIALS:

1. BODY & CONTACT = BERYLLIUM COPPER PER ASTM B196, ALLOY C17300, TEMPER TD04.
2. INSULATOR = VIRGIN WHITE TEFLON PER ASTM D1710, GRADE 1, TYPE I, CLASS "B".
3. CRIMP SLEEVE = SEAMLESS LOWLEAD BRASS TUBE, ALLOY 330, SOFT ANNEAL TEMPER, .025/.060 GRAIN SIZE OR SEAMLESS COPPER TUBE PER ASTM B75, TYPE C12000, TEMPER: LIGHT ANNEAL O50 EXCEPT YIELD STRENGTH.
4. ALL OTHER METAL PARTS = BRASS PER ASTM B16, ALLOY C36000, TEMPER H02.

FINISHES:

1. CONTACT = GOLD PLATE PER MIL-G-45204, TYPE II, CLASS 1, GRADE C, OVER .00010 TO .00020 STRESS FREE SULFAMATE NICKEL PER QQ-N-290.
2. ALL OTHER METAL PARTS = GOLD PLATE PER MIL-G-45204, TYPE II, CLASS 0, GRADE C, OVER .00010 TO .00020 COPPER STRIKE PER MIL-C-14550.

SHRINK SLEEVE NOT SHOWN

UNLESS OTHERWISE SPECIFIED DIMENSIONS ARE IN INCHES TOLERANCES ON		DWN: D.N.	DATE: 05/30/12	 Property of Radiall This document cannot be reproduced or communicated to a third party without prior written permission of RADIALL.	
DECIMAL	ANGLE	CHKD: J.S.	DATE: 05/30/12		
		APVD: J.M.	DATE: 05/30/12		
REFERENCE:		MATERIALS & FINISHES: SEE NOTES		SSMB RIGHT ANGLE PLUG CRIMP TYPE FOR RG-178 & SIMILAR CABLE	
ORIGINATED: D.N. DATE: 05/30/12		SIZE: A	FSCM NO.: 19505	DWG NO.: 7405-1521-802	REV: A00
		SCALE: 8:1	THIRD ANGLE PROJECTION		SHEET 1 OF 1

7405-1521-802