

UM11835

Introduction to the FRDMSTBI-NMH1000 shield board

Rev. 1 — 10 October 2022

User manual

Document information

Information	Content
Keywords	Magnetic switch, hall effect magnetic field sensor, FRDMSTBI-NMH1000, shield board, evaluation, board, evaluation hardware, ecosystem, NMH1000
Abstract	This document introduces the FRMDSTBI-NMH1000 shield board and explains where to find resources, how to install, configure, and use the tools associated with the board.



Revision history

Rev	Date	Description
v.1	20221010	initial version

IMPORTANT NOTICE**For engineering development or evaluation purposes only**

NXP provides the product under the following conditions:

This evaluation kit is for use of **ENGINEERING DEVELOPMENT OR EVALUATION PURPOSES ONLY**. It is provided as a sample IC pre-soldered to a printed-circuit board to make it easier to access inputs, outputs and supply terminals. This evaluation board may be used with any development system or other source of I/O signals by connecting it to the host MCU computer board via off-the-shelf cables. This evaluation board is not a Reference Design and is not intended to represent a final design recommendation for any particular application. Final device in an application heavily depends on proper printed-circuit board layout and heat sinking design as well as attention to supply filtering, transient suppression, and I/O signal quality.

The product provided may not be complete in terms of required design, marketing, and or manufacturing related protective considerations, including product safety measures typically found in the end device incorporating the product. Due to the open construction of the product, it is the responsibility of the user to take all appropriate precautions for electric discharge. In order to minimize risks associated with the customers' applications, adequate design and operating safeguards must be provided by the customer to minimize inherent or procedural hazards. For any safety concerns, contact NXP sales and technical support services.

1 Introduction

The FRDMSTBI-NMH1000 is an evaluation board comprised of all necessary headers, jumpers, and signal test points to quickly evaluate the NMH1000 magnetic sensor.

This document is intended to help a user quickly set up, configure and operate the FRDMSTBI-NMH1000 evaluation board.

2 Finding kit resources and information on the NXP web site

NXP Semiconductors provides online resources for this evaluation board and its supported device(s) on <http://www.nxp.com>.

The information page for the magnetic sensor, NMH1000, and the FRDMSTBI-NMH1000 evaluation shield board can be found at:

<http://www.preview.nxp.com/products/sensors/magnetic-angular-position-sensors/nmh1000-ultra-low-power-and-low-voltage-magnetic-switch:NMH1000>

The information page provides overview information, documentation, software and tools, ordering information and a Getting Started tab. The Getting Started tab provides quick-reference information applicable to using the FRDMSTBI-NMH1000, including the downloadable assets referenced in this document.

2.1 Collaborate in the NXP community

The NXP Community is for sharing ideas and tips, asking and answering technical questions, and receiving input on just about any embedded design topic.

The NXP Community is at <http://community.nxp.com>.

3 Getting ready

Working with the FRDMSTBI_NMH1000 evaluation shield board also requires a FRDM-KE15Z MCU board, a PC and project demo software available at NXP.com.

3.1 Kit contents

The FRDMSTBI-NMH1000 contents include:

- FRDMSTBI-NMH1000 shield board with Arduino headers

3.2 Additional hardware

The FRDMSTBI-NMH1000 can be paired with NXP MCU boards of your choice, however there is a demo project provided for the FRDM-KE15Z MCU board for evaluation. Detailed information is provided in [Section 4 "Getting to know the hardware"](#).

3.3 Static handling requirements

CAUTION

This device is sensitive to ElectroStatic Discharge (ESD). Therefore care should be taken during transport and handling. You must use a ground strap or touch the PC case or other grounded source before unpacking or handling the hardware.

3.4 Minimum system requirements

The FRDMSTBI-NMH1000 evaluation board requires a Windows 10 PC workstation and a Freedom FRDM-KE15Z MCU board.

3.5 Software

Installing software is necessary to work with this evaluation board. All listed software is available on the evaluation board's information page at <https://www.nxp.com/products/sensors/magnetic-sensors/nmh1000-ultra-low-power-and-low-voltage-magnetic-switch:NMH1000>.

4 Getting to know the hardware

4.1 Kit overview

The FRDMSTBI-NMH1000 shield board incorporates a NMH1000 fully integrated magnetic sensor that provides a small footprint, low current and low operating voltage, I²C mode or standalone mode capabilities.

The FRDMSTBI-NMH1000 shield board can be easily connected to a NXP Freedom MCU board via the Arduino headers for evaluation (See [Section 5 "Configuring the hardware"](#)). The following board is recommended:

- FRDM-KE15Z

The user can connect the two boards for evaluation of the NMH1000 magnetic sensor with either a terminal program using the NXP provided Component Library [Section 5 "Configuring the hardware"](#) or standalone use. In either use case, the hardware helps users in their software development.

These evaluation boards provide an intuitive way to change between the sensors standalone modes and using the I²C interface for communication through jumper selections as well as providing test points that are typically used for evaluation. The NMH1000 datasheet provides additional information and configuration details.

4.2 NMH1000 magnetic sensor board features

The NMH1000 is a hall effect magnetic field sensor that is most sensitive to a vertical field passing through the top-to-bottom surfaces, orthogonal to the plane of the application printed circuit board. The sensor operates at low voltage, low current, low output data rate, and is a small physical size. Features include:

- Z- axis Hall effect switch for axial magnets
 - North and South polarity sensitivity

- Low operating voltage down to 1.2 V
- Ultra-low power consumption
 - 75 nA typ. @ 1 Hz sample rate
- Industrial operating temperature range
 - -40 °C to 85 °C
- Selectable Modes
 - Standalone Mode
 - Threshold selection 3-state hardware pin (70 Gauss, 140 Gauss or 210 Gauss)
 - Samples rate selection 3-state hardware pin (0.1 Hz, 1.0 Hz, 10 Hz)
 - I²C User Mode
 - Threshold selection data bits
 - Sample rate selection data bits (0.1 Hz to 100 Hz)
- Binary state hardware pin output; programmable polarity in I²C User Mode
- Small Form Factor Packaging
 - DFN 1.4 x 1.4 x 0.85 mm
 - 6 pins, 0.5 mm pitch

4.3 Block diagram examples

Example block diagrams of the NMH1000 with an external host is shown in [Figure 1](#) and [Figure 2](#).

[Figure 1](#) shows the I²C circuit setup where the NMH1000 mode is set to V_{DD} and the output signal is sent to the host.

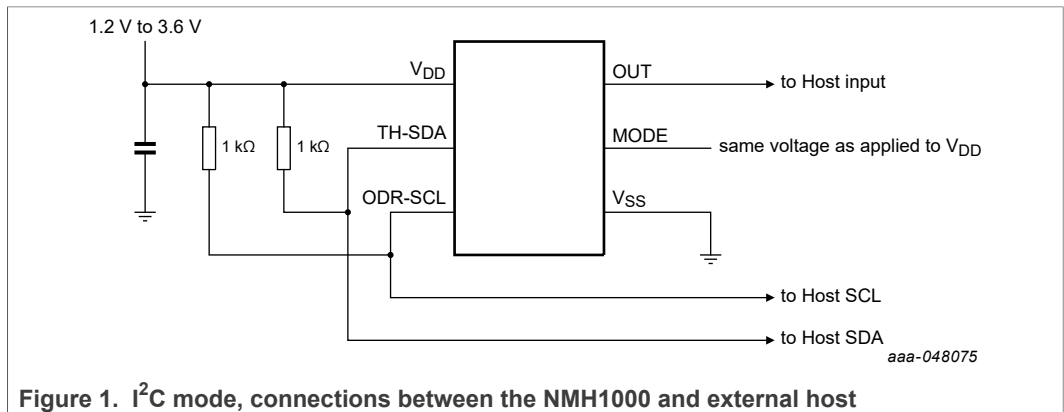

[Figure 2](#) shows the standalone mode circuit setup where the NMH1000 mode is set to GND and the output signal is sent to the host.

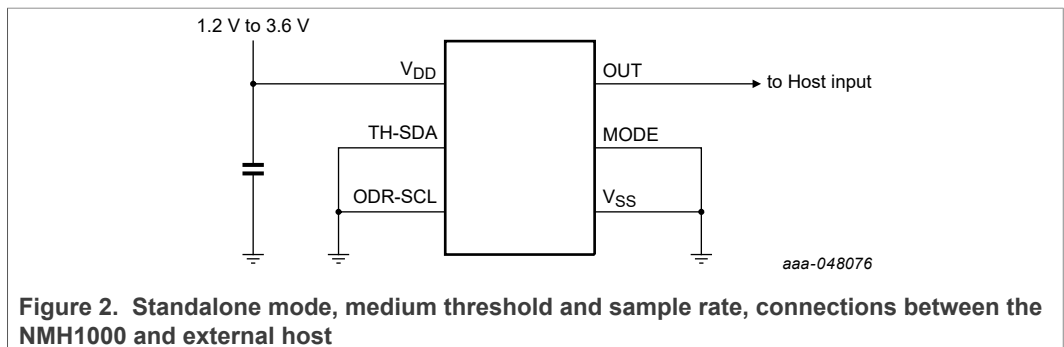

4.4 Kit featured components

Figure 3 identifies important components on the board and Table 1 provides additional details on these components.

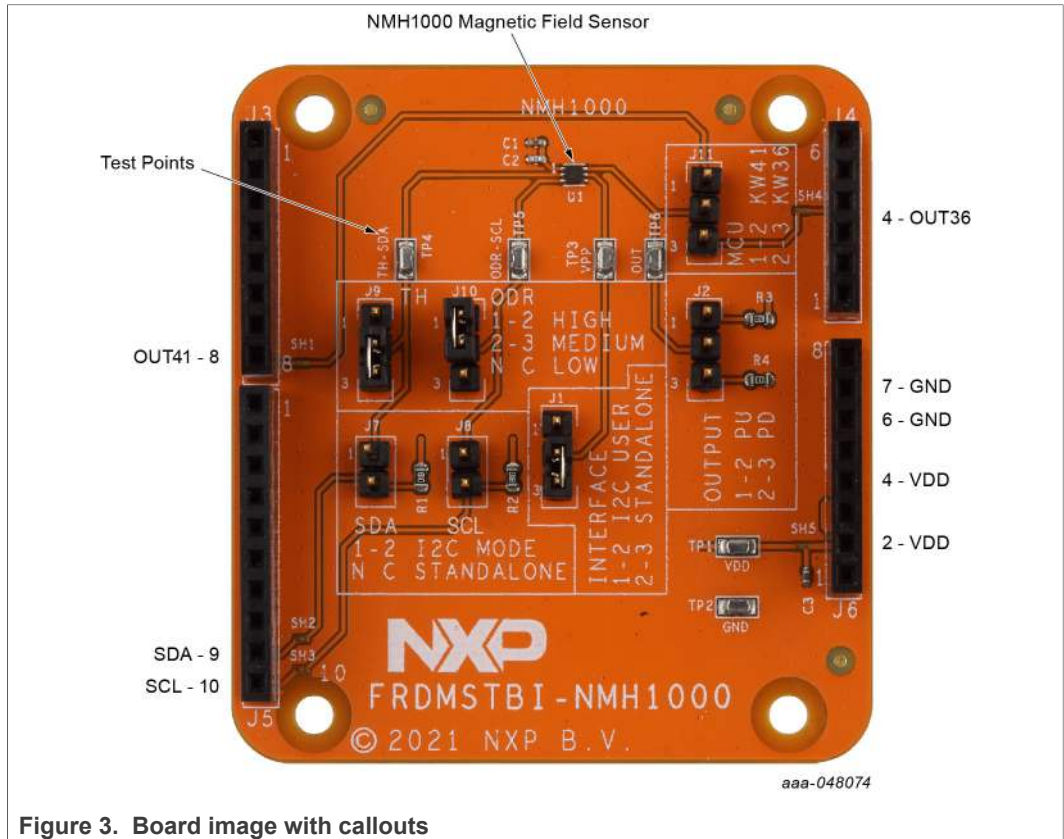

Figure 3. Board image with callouts

The FRDMSTBI-NMH1000 shield board comes with standard Arduino headers and can be paired with NXP Freedom MCU boards for user evaluations and software development. For quick evaluation and prototyping, NXP provides a demo project targeted to the FRDM-KE15Z board and the hardware design files for fast time to market.

Table 1. Evaluation board featured components location

Number	Description
U1	NMH1000 magnetic field sensor
J3	OUT41, pin 8
J4	OUT36, pin 4
J5	SDA, pin 9, SCL, pin 10
J6	VDD, pins 2, 4, GND, pins 6, 7

As labeled in the figure, the following signals are available on the Arduino headers and the selectable signal headers of the FRDMSTBI-NMH1000 shield board:

- The interface or sensor modes are selected by J1
 - I²C mode: J1, 1-2; J7 and J8 ON (placed)

- Standalone mode: J1, 2-3; J7 and J8 OFF (open)
- Standalone mode:
 - Threshold selection (low, med, high) is selected by jumper J9
 - Sampling rate or ODR (low, med, high) is selected by jumper J10
- The I²C interface is provided through J5. These are:
 - J5-9, SDA, Serial data
 - J5-10, SCL, Serial clock
- J11, pin 6 output section to either J4, 4 or J3, 8
- J2, pullup/pull down selection
- VDD is supplied through J6-2 / J6-4. This is typically supplied through a Freedom MCU board; i.e. FRDM-KE15Z.
- GND is supplied through J6-6 / J6-7. This is typically supplied through a Freedom MCU board; i.e. FRDM-KE15Z.

4.4.1 Connectors

Table 2. NMH1000 connectors

Connectors	Description
J3	Eight pin connector
J4	Six pin connector
J5	Ten pin connector
J6	Eight pin connector

4.4.2 Test points

Table 3. NMH1000 test points

Test Points	Description
TP1	V _{DD}
TP2	GND
TP3	V _{PP}
TP4	TH-SDA
TP5	ODR-SCL
TP6	Out

4.4.3 Jumpers

Table 4. NMH1000 jumpers

Jumper	Description
J1	Interface, I ² C user or standalone
J2	Output
J7	SDA
J8	SCL
J9	TH
J10	ODR

Table 4. NMH1000 jumpers...continued

Jumper	Description
J11	MCU

4.4.4 Switches

Table 5. NMH1000 switches

Switch	Description
SH1	Short
SH2	Short
SH3	Short
SH4	Short
SH5	Short

4.5 FRDMSTBI-NMH1000 hardware design files

The FRDMSTBI-NMH1000 shield board design files can be found and downloaded from the NMH1000 product page under the Tools and Software tab. See [Section 6](#) for applicable documents and links.

4.6 Schematic, board layout and bill of materials

The schematic, board layout and bill of materials for the FRDMSTBI-NMH1000 evaluation board are located on the design resources tab at <https://www.nxp.com/products/sensors/magnetic-sensors/nmh1000-ultra-low-power-and-low-voltage-magnetic-switch:NMH1000>.

5 Configuring the hardware

[Figure 4](#) presents the typical hardware configuration incorporating the FRDMSTBI-NMH1000 evaluation board with standard Arduino headers combined with the FRDM-KE15Z Freedom MCU board.

NXP provides a Component Library software example for quick evaluation and prototyping. The demo project is targeted to the FRDM-KE15Z and is located under Design Resources, BSP, DRIVERS AND MIDDLEWARE at the following link: <https://www.nxp.com/products/sensors/magnetic-sensors/nmh1000-ultra-low-power-and-low-voltage-magnetic-switch:NMH1000>

Download the driver NMH1000 sensor driver with examples.



Figure 4. Typical initial configuration

6 References

- [1] NMH1000 — Magnetic field sensor product page. <https://www.nxp.com/products/sensors/magnetic-sensors/nmh1000-ultra-low-power-and-low-voltage-magnetic-switch:NMH1000>
- [2] FRDMSTBI-NMH1000 design files — Tools and software tab. <https://www.nxp.com/design/sensor-developer-resources/sensor-sw-component-library/sensor-drivers-for-nxp-sensors:SENSOR-DRIVERS>

7 Legal information

7.1 Definitions

Draft — A draft status on a document indicates that the content is still under internal review and subject to formal approval, which may result in modifications or additions. NXP Semiconductors does not give any representations or warranties as to the accuracy or completeness of information included in a draft version of a document and shall have no liability for the consequences of use of such information.

7.2 Disclaimers

Limited warranty and liability — Information in this document is believed to be accurate and reliable. However, NXP Semiconductors does not give any representations or warranties, expressed or implied, as to the accuracy or completeness of such information and shall have no liability for the consequences of use of such information. NXP Semiconductors takes no responsibility for the content in this document if provided by an information source outside of NXP Semiconductors.

In no event shall NXP Semiconductors be liable for any indirect, incidental, punitive, special or consequential damages (including - without limitation - lost profits, lost savings, business interruption, costs related to the removal or replacement of any products or rework charges) whether or not such damages are based on tort (including negligence), warranty, breach of contract or any other legal theory.

Notwithstanding any damages that customer might incur for any reason whatsoever, NXP Semiconductors' aggregate and cumulative liability towards customer for the products described herein shall be limited in accordance with the Terms and conditions of commercial sale of NXP Semiconductors.

Right to make changes — NXP Semiconductors reserves the right to make changes to information published in this document, including without limitation specifications and product descriptions, at any time and without notice. This document supersedes and replaces all information supplied prior to the publication hereof.

Suitability for use — NXP Semiconductors products are not designed, authorized or warranted to be suitable for use in life support, life-critical or safety-critical systems or equipment, nor in applications where failure or malfunction of an NXP Semiconductors product can reasonably be expected to result in personal injury, death or severe property or environmental damage. NXP Semiconductors and its suppliers accept no liability for inclusion and/or use of NXP Semiconductors products in such equipment or applications and therefore such inclusion and/or use is at the customer's own risk.

Applications — Applications that are described herein for any of these products are for illustrative purposes only. NXP Semiconductors makes no representation or warranty that such applications will be suitable for the specified use without further testing or modification.

Customers are responsible for the design and operation of their applications and products using NXP Semiconductors products, and NXP Semiconductors accepts no liability for any assistance with applications or customer product design. It is customer's sole responsibility to determine whether the NXP Semiconductors product is suitable and fit for the customer's applications and products planned, as well as for the planned application and use of customer's third party customer(s). Customers should provide appropriate design and operating safeguards to minimize the risks associated with their applications and products.

NXP Semiconductors does not accept any liability related to any default, damage, costs or problem which is based on any weakness or default in the customer's applications or products, or the application or use by customer's third party customer(s). Customer is responsible for doing all necessary testing for the customer's applications and products using NXP Semiconductors products in order to avoid a default of the applications and the products or of the application or use by customer's third party customer(s). NXP does not accept any liability in this respect.

Terms and conditions of commercial sale — NXP Semiconductors products are sold subject to the general terms and conditions of commercial sale, as published at <http://www.nxp.com/profile/terms>, unless otherwise agreed in a valid written individual agreement. In case an individual agreement is concluded only the terms and conditions of the respective agreement shall apply. NXP Semiconductors hereby expressly objects to applying the customer's general terms and conditions with regard to the purchase of NXP Semiconductors products by customer.

Export control — This document as well as the item(s) described herein may be subject to export control regulations. Export might require a prior authorization from competent authorities.

Suitability for use in non-automotive qualified products — Unless this data sheet expressly states that this specific NXP Semiconductors product is automotive qualified, the product is not suitable for automotive use. It is neither qualified nor tested in accordance with automotive testing or application requirements. NXP Semiconductors accepts no liability for inclusion and/or use of non-automotive qualified products in automotive equipment or applications.

In the event that customer uses the product for design-in and use in automotive applications to automotive specifications and standards, customer (a) shall use the product without NXP Semiconductors' warranty of the product for such automotive applications, use and specifications, and (b) whenever customer uses the product for automotive applications beyond NXP Semiconductors' specifications such use shall be solely at customer's own risk, and (c) customer fully indemnifies NXP Semiconductors for any liability, damages or failed product claims resulting from customer design and use of the product for automotive applications beyond NXP Semiconductors' standard warranty and NXP Semiconductors' product specifications.

Translations — A non-English (translated) version of a document, including the legal information in that document, is for reference only. The English version shall prevail in case of any discrepancy between the translated and English versions.

Security — Customer understands that all NXP products may be subject to unidentified vulnerabilities or may support established security standards or specifications with known limitations. Customer is responsible for the design and operation of its applications and products throughout their lifecycles to reduce the effect of these vulnerabilities on customer's applications and products. Customer's responsibility also extends to other open and/or proprietary technologies supported by NXP products for use in customer's applications. NXP accepts no liability for any vulnerability. Customer should regularly check security updates from NXP and follow up appropriately. Customer shall select products with security features that best meet rules, regulations, and standards of the intended application and make the ultimate design decisions regarding its products and is solely responsible for compliance with all legal, regulatory, and security related requirements concerning its products, regardless of any information or support that may be provided by NXP.

NXP has a Product Security Incident Response Team (PSIRT) (reachable at PSIRT@nxp.com) that manages the investigation, reporting, and solution release to security vulnerabilities of NXP products.

7.3 Trademarks

Notice: All referenced brands, product names, service names, and trademarks are the property of their respective owners.

NXP — wordmark and logo are trademarks of NXP B.V.

Tables

Tab. 1.	Evaluation board featured components location	7	Tab. 3.	NMH1000 test points	8
Tab. 2.	NMH1000 connectors	8	Tab. 4.	NMH1000 jumpers	8
			Tab. 5.	NMH1000 switches	9

Figures

Fig. 1.	I2C mode, connections between the NMH1000 and external host	6	Fig. 3.	Board image with callouts	7
Fig. 2.	Standalone mode, medium threshold and sample rate, connections between the NMH1000 and external host	6	Fig. 4.	Typical initial configuration	10

Contents

1	Introduction	4
2	Finding kit resources and information on the NXP web site	4
2.1	Collaborate in the NXP community	4
3	Getting ready	4
3.1	Kit contents	4
3.2	Additional hardware	4
3.3	Static handling requirements	5
3.4	Minimum system requirements	5
3.5	Software	5
4	Getting to know the hardware	5
4.1	Kit overview	5
4.2	NMH1000 magnetic sensor board features	5
4.3	Block diagram examples	6
4.4	Kit featured components	7
4.4.1	Connectors	8
4.4.2	Test points	8
4.4.3	Jumpers	8
4.4.4	Switches	9
4.5	FRDMSTBI-NMH1000 hardware design files	9
4.6	Schematic, board layout and bill of materials	9
5	Configuring the hardware	9
6	References	10
7	Legal information	11

Please be aware that important notices concerning this document and the product(s) described herein, have been included in section 'Legal information'.
