



85V Half Bridge MOSFET Drivers with 5.5V to 16V Gate Drive

MIC4604 Evaluation Board

General Description

The MIC4604 is an 85V Half Bridge MOSFET driver. The MIC4604 features fast 39ns propagation delay times and 20ns driver rise/fall times for a 1nF capacitive load. The low-side and high-side gate drivers are independently controlled. The MIC4604 has TTL input thresholds. It includes a high-voltage internal diode that helps charge the high-side gate drive bootstrap capacitor.

The MIC4604YM Evaluation Board comes with the MIC4604YM SOIC package, while the MIC4604YMT Evaluation Board comes with the MIC4604YMT TDFN package.

Datasheets and support documentation are available on Micrel's web site at: www.micrel.com.

Requirements

At a minimum, the evaluation board requires a 5.5V to 16V power supply to power the VDD terminal (J1) of the MIC4604 and another supply (up to 85V) may be used to power the MOSFETs connected to the VIN terminal (J2). A pulse generator or the output of a PWM control IC may be connected to the HI and LI terminals.

Precautions

There is no reverse input protection on this board. When connecting the input sources, make sure that the correct polarity is observed.

Under extreme load conditions and with a high supply voltage (>48V) connected to the VIN terminal (J2), input transients can be quite large if long test leads are used. In such cases a 100 μ F, 100V electrolytic capacitor is needed across the VIN terminals to prevent overvoltage damage to the IC. This can be removed if a clean supply voltage on VIN is always guaranteed.

Because there is no non-overlap protection, always ensure that the HI/LI inputs are connected to non-overlapping clock signals as shown in Figures 1, 2, 3, and 4. If both HI and LI are ON at the same time, then HO and LO will be high at the same time and turn ON both the MOSFETs, thus shorting the VIN supply to GND.

Getting Started

1. **Connect V_{IN} supply between the VIN and GND terminals and V_{DD} supply between the VDD and GND terminals.**

Connect a supply between the VIN terminal (J2) and the GND terminal (J3), paying careful attention to polarity and supply range ($V_{IN} \leq 85V$). Do not apply power until Step 5.

Connect a supply between the VDD terminal (J1) and the GND terminal (J3), paying careful attention to polarity and supply range ($5.5V \leq V_{DD} < 16V$). Do not apply power until Step 5.

2. **Connect the TTL-compatible HI and LI inputs.**

Connect the HI input (JP2) and LI input (JP3) to a pulse generator or the output of a PWM control IC. Ensure that they are non-overlapping signals and are TTL compatible logic-levels.

3. **Monitor inputs and outputs.**

Monitor the inputs HI (JP2) and LI (JP3) and outputs HO (JP1) and LO (JP4) with an oscilloscope.

4. **Connect motor across HS and GND or connect HS to GND.**

The simplest way to observe the MIC4604 operation is to connect a motor across the HS terminal (J8) and GND (J9). Alternatively the HS terminal (J8) can be shorted to GND (J9) with the V_{IN} supply turned OFF. DC and AC parameters can be easily measured in this configuration.

5. **Turn on supplies and HI/LI inputs.**

Turn on the V_{IN} power supply followed by the V_{DD} power supply. Turn on the HI and LI inputs.

Ordering Information

Part Number	Description
MIC4604YM EV	85V Half Bridge Driver Evaluation Board with MIC4604YM device.
MIC4604YMT EV	85V Half Bridge Driver Evaluation Board with MIC4604YMT device.

Evaluation Board Performance

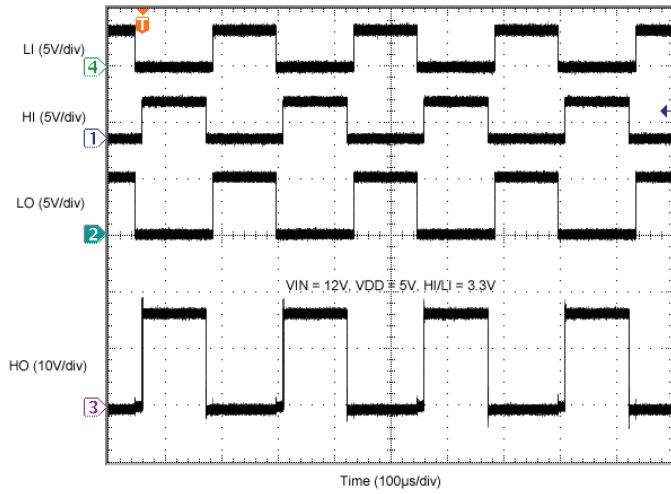

Figure 1. 4kHz Motor Operation Showing LI, HI, LO, and HO Signals

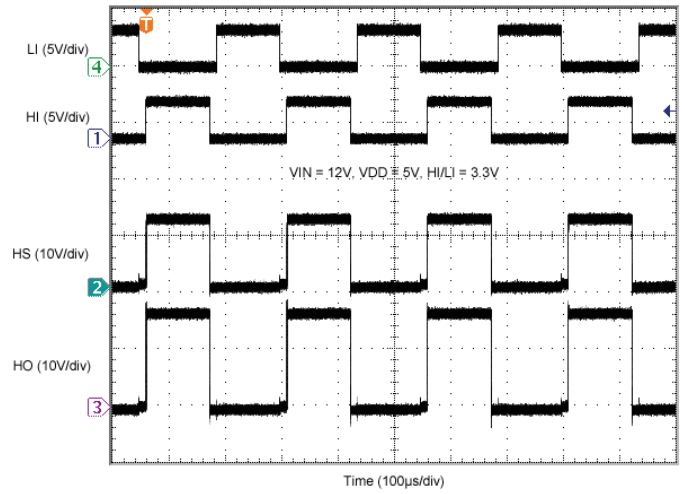

Figure 2. 4kHz Motor Operation Showing LI, HI, HS, and HO Signals

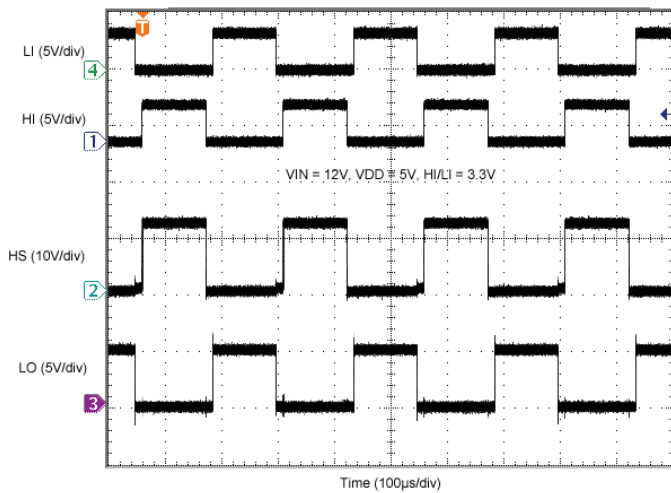

Figure 3. 4kHz Motor Operation Showing LI, HI, HS, and LO Signals

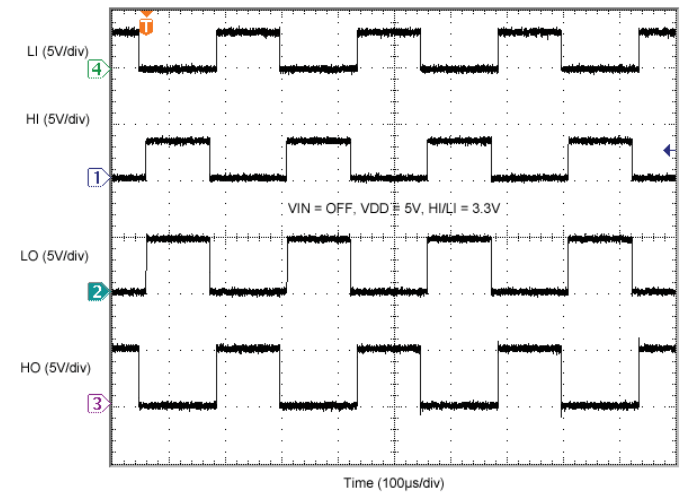
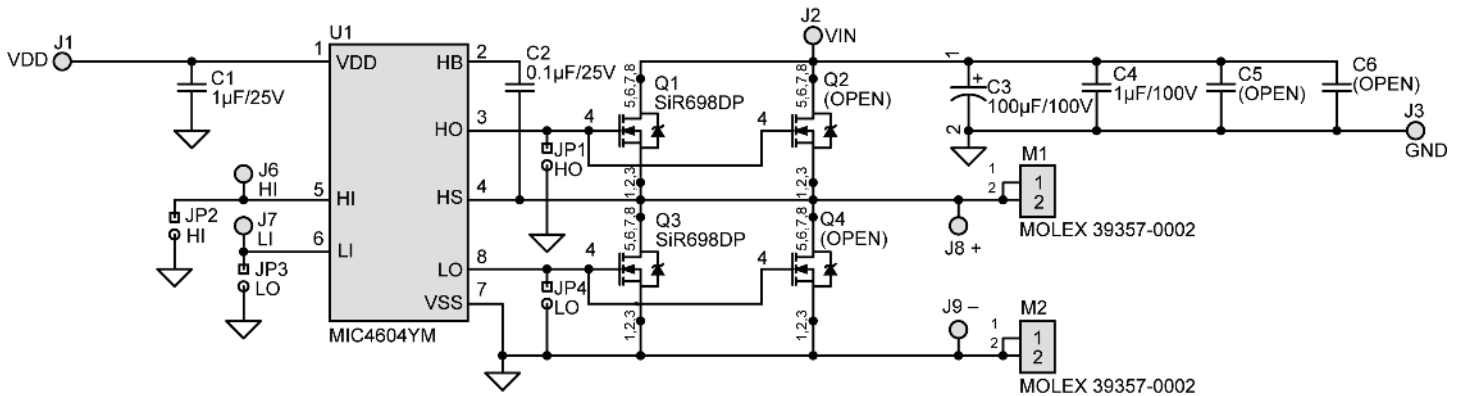

Figure 4. HS tied to GND Showing LI, HI, LO, and HO Signals

Evaluation Board Schematic (MIC4604YM)



Bill of Materials

Item	Part Number	Manufacturer	Description	Qty.
C1	C1608X7R1E105K	TDK ⁽¹⁾	1.0µF Ceramic Capacitor, 25V, X7R, Size 0603	1
	GRM188R71E105KA12D	Murata ⁽²⁾		
C2	C1608X7R1E104K	TDK	0.1µF Ceramic Capacitor, 25V, X7R, Size 0603	1
	06033C104KAT2A	AVX ⁽³⁾		
	GRM188R71E104KA01D	Murata		
C3	ECA-2AHG101	Panasonic ⁽⁴⁾	100µF, 100V, Radial Electrolytic Capacitor,	1
	515D107M100DG6AE3	Vishay ⁽⁵⁾		
C4	CGA5L2X7R2A105K	TDK	1.0µF Ceramic Capacitor, 100V, X7R, Size 1206	1
	12061C105K4Z4A	AVX		
	GRF31CR72A105KA01L	Murata		
Q1, Q3	SiR698DP-T1-GE3	Vishay	100V , N-channel MOSFET , SO8	2
U1	MIC4604YM	Micrel, Inc. ⁽⁶⁾	85V Half Bridge MOSFET Drivers with 5.5V to 16V Gate Drive	1

Notes:

1. TDK: www.tdk.com
2. Murata: www.murata.com
3. AVX: www.avx.com
4. Panasonic: www.panasonic.com
5. Vishay Dale: www.vishay.com.
6. Micrel, Inc.: www.micrel.com.

PCB Layout Recommendations

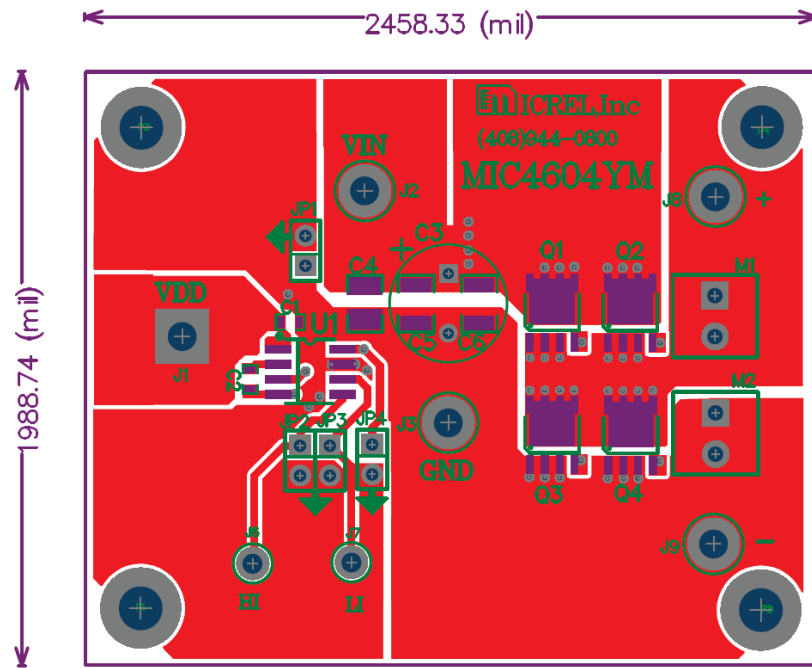

Top Layer: 8-Pin SOIC (M)

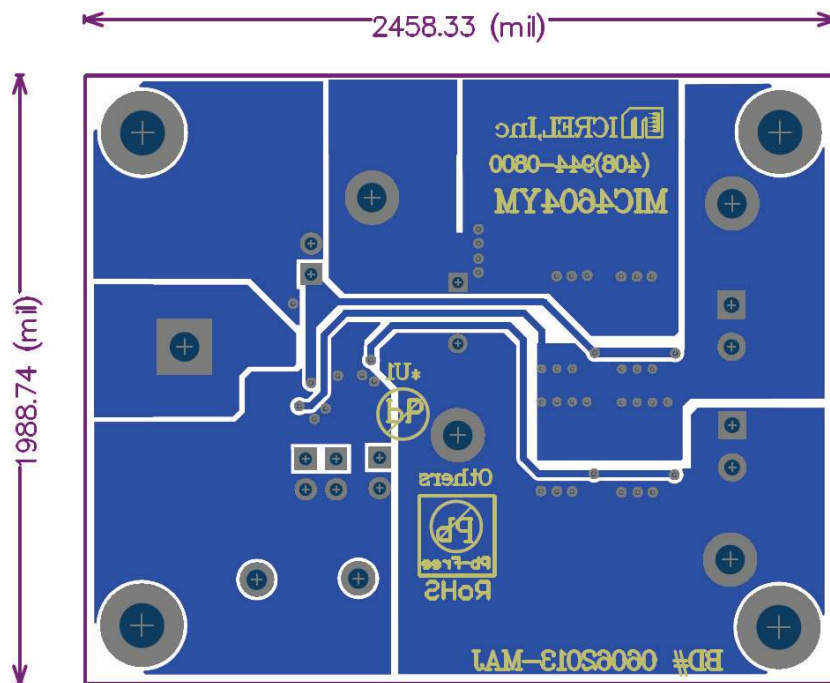

Bottom Layer: 8-Pin SOIC (M)

Evaluation Board Schematic (MIC4604YMT)

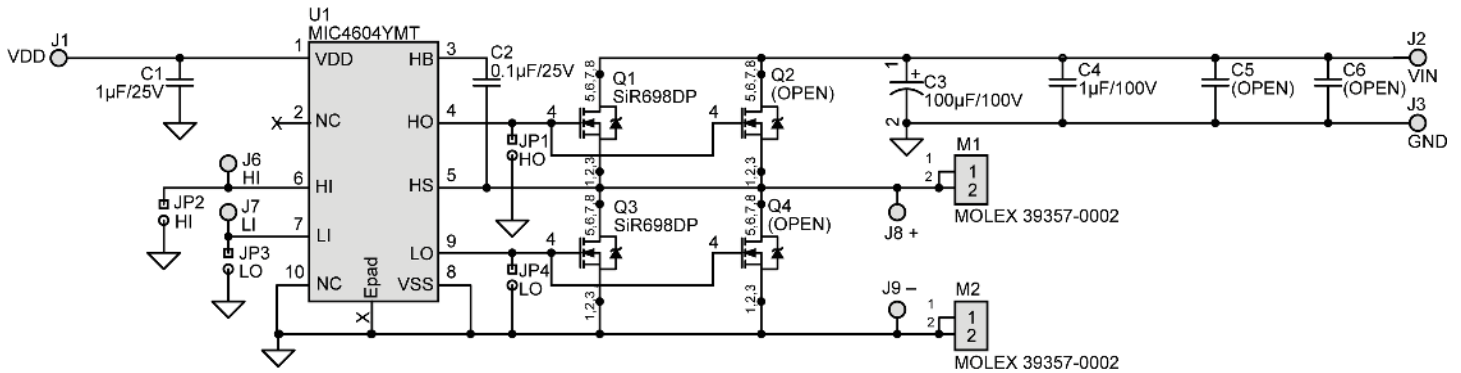

Bill of Materials

Item	Part Number	Manufacturer	Description	Qty.
C1	C1608X7R1E105K	TDK ⁽¹⁾	1.0µF Ceramic Capacitor, 25V, X7R, Size 0603	1
	GRM188R71E105KA12D	Murata ⁽²⁾		
C2	C1608X7R1E104K	TDK	0.1µF Ceramic Capacitor, 25V, X7R, Size 0603	1
	06033C104KAT2A	AVX ⁽³⁾		
	GRM188R71E104KA01D	Murata		
C3	ECA-2AHG101	Panasonic ⁽⁴⁾	100µF, 100V, Radial Electrolytic Capacitor,	1
	515D107M100DG6AE3	Vishay ⁽⁵⁾		
C4	CGA5L2X7R2A105K	TDK	1.0µF Ceramic Capacitor, 100V, X7R, Size 1206	1
	12061C105K4Z4A	AVX		
	GRF31CR72A105KA01L	Murata		
Q1, Q3	SiR698DP-T1-GE3	Vishay	100V , N-channel MOSFET , SO8	2
U1	MIC4604YMT	Micrel, Inc. ⁽⁶⁾	85V Half Bridge MOSFET Drivers with 5.5V to 16V Gate Drive	1

Notes:

1. TDK: www.tdk.com
2. Murata: www.murata.com
3. AVX: www.avx.com
4. Panasonic: www.panasonic.com
5. Vishay Dale: www.vishay.com.
6. Micrel, Inc.: www.micrel.com

PCB Layout Recommendations

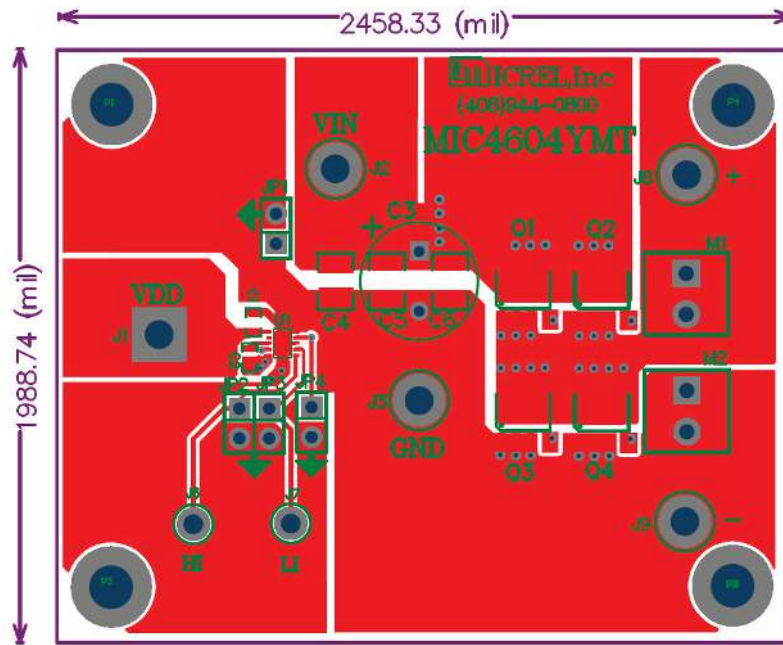

Top Layer: 2.5mm x 2.5mm TDFN-10L (MT)

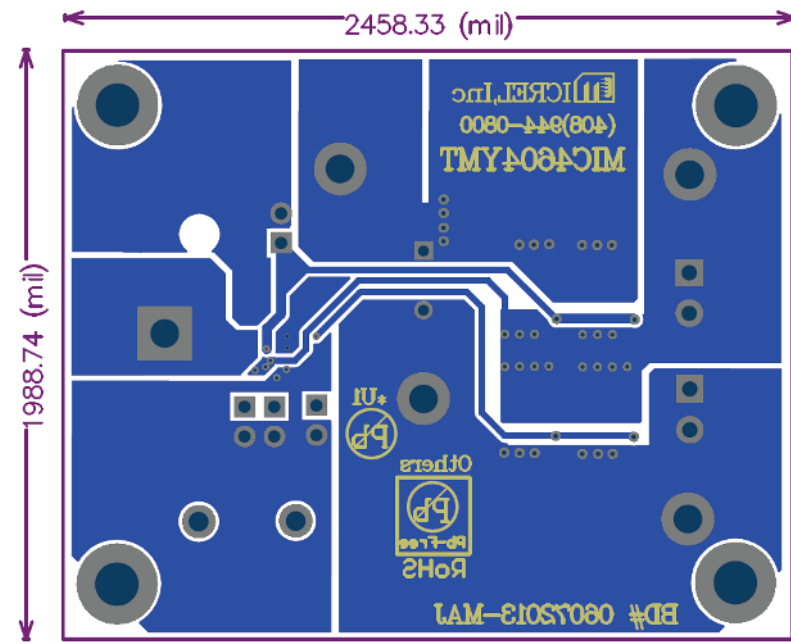

Bottom Layer: 2.5mm x 2.5mm TDFN-10L (MT)

MICREL, INC. 2180 FORTUNE DRIVE SAN JOSE, CA 95131 USATEL +1 (408) 944-0800 FAX +1 (408) 474-1000 WEB <http://www.micrel.com>

Micrel makes no representations or warranties with respect to the accuracy or completeness of the information furnished in this data sheet. This information is not intended as a warranty and Micrel does not assume responsibility for its use. Micrel reserves the right to change circuitry, specifications and descriptions at any time without notice. No license, whether express, implied, arising by estoppel or otherwise, to any intellectual property rights is granted by this document. Except as provided in Micrel's terms and conditions of sale for such products, Micrel assumes no liability whatsoever, and Micrel disclaims any express or implied warranty relating to the sale and/or use of Micrel products including liability or warranties relating to fitness for a particular purpose, merchantability, or infringement of any patent, copyright or other intellectual property right.

Micrel Products are not designed or authorized for use as components in life support appliances, devices or systems where malfunction of a product can reasonably be expected to result in personal injury. Life support devices or systems are devices or systems that (a) are intended for surgical implant into the body or (b) support or sustain life, and whose failure to perform can be reasonably expected to result in a significant injury to the user. A Purchaser's use or sale of Micrel Products for use in life support appliances, devices or systems is a Purchaser's own risk and Purchaser agrees to fully indemnify Micrel for any damages resulting from such use or sale.

© 2013 Micrel, Incorporated.