

NOTES:

1.0 MATERIALS

- 1.1 HOUSING AND COUPLING NUT: STAINLESS STEEL PER ASTM-A582, TYPE 303.
- 1.2 CENTER CONTACT: BERYLLIUM COPPER ROD PER ALLOY C172, PER ASTM B196.
- 1.3 DIELECTRIC: PTFE FLUOROCARBON PER ASTM-D1457.

2.0 PLATING

- 2.1 HOUSING AND COUPLING NUT: PASSIVATED PER QQ-P-35 AND MIL-F-14072.
- 2.2 CENTER CONTACT: GOLD PER MIL-G-45204 TYPE II, CLASS 2.

3.0 ELECTRICAL SPECIFICATIONS

- 3.1 FREQUENCY RANGE: DC to 18.0 GHz.
- 3.2 VSWR (MAX): 1.07 +.015 fGHz
- 3.3 IMPEDANCE: 50 OHMS

4.0 MARKING

- 4.1 MARK UNIT AS SHOWN:
(REF: INK-04398-27-01)

5.0 DIMENSIONS IN PARENTHESIS ARE MILLIMETERS.

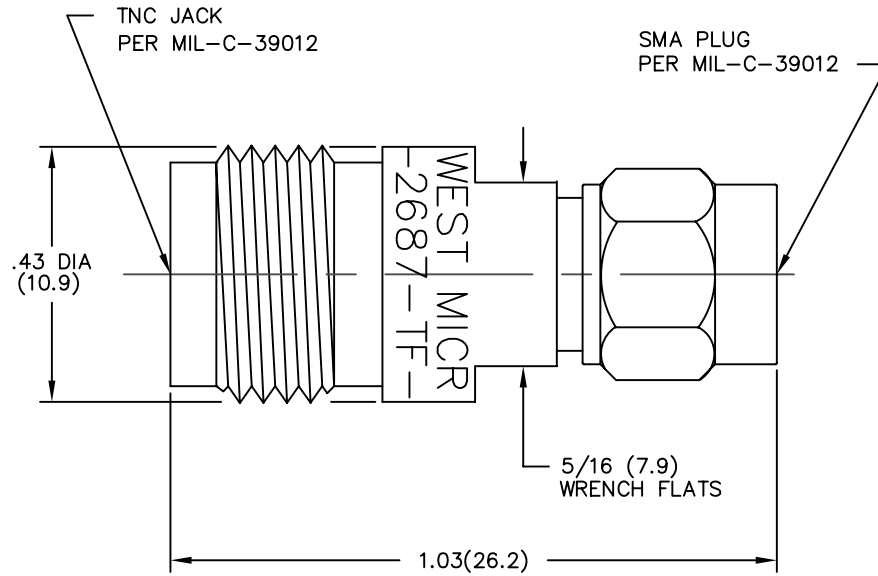

MODEL NUMBER
ADT-2687-TF-SMM-02

REV.	DESCRIPTION	DATE
I	RELEASED	5/10/82
A	ECR 7527	5/19/82
B	ECR 1562	6/21/82
C	ECR 1745	10/12/84
D	ECR 6545	7/10/89
E	UPDATE MOD #	8/5/92
F	UPDATE ON CAD	11/23/92
G	ECN 17289	9/27/98
	ECN 18332	1/25/02

DWG. NO. WAS 04179-01-00

<p>NOTICE: The information contained in this drawing is proprietary and must not be used without the permission of Emerson Network Power.</p> <p>UNLESS OTHERWISE NOTED DIMENSIONS ARE IN INCHES AND TOLERANCES ARE: 3 PLACE DECIMALS ±.005 2 PLACE DECIMALS ±.02 FRACTIONS ±1/64 PARALLELITY: T.I.R. _____ FLATNESS: T.I.R. _____ CONCENTRICITY: T.I.R. _____ ANGLES AND PERPENDICULARITY: ±1'</p>	<p>CAGE CODE 34078</p>	<p>MIDWEST MICROWAVE</p>	
	<p>EMERSON Network Power Connectivity Solutions</p>		<p>TITLE ADAPTER OUTLINE DRAWING</p>
<p>DRAWN/DATE M.HOLLMAN 11/23/92</p>	<p>ENG./DATE A.OSGA 12/2/92</p>	<p>DRAWING NUMBER ADT-2687-TF-SMM-02-01</p>	<p>REV. G</p>
<p>CHECKED/DATE A.BEATTY 12/1/92</p>	<p>APPROVED/DATE</p>	<p>SCALE: 5=1</p>	<p>SHEET 1 of 1</p>