

To our customers,

Old Company Name in Catalogs and Other Documents

On April 1st, 2010, NEC Electronics Corporation merged with Renesas Technology Corporation, and Renesas Electronics Corporation took over all the business of both companies. Therefore, although the old company name remains in this document, it is a valid Renesas Electronics document. We appreciate your understanding.

Renesas Electronics website: <http://www.renesas.com>

April 1st, 2010
Renesas Electronics Corporation

Issued by: Renesas Electronics Corporation (<http://www.renesas.com>)

Send any inquiries to <http://www.renesas.com/inquiry>.

Notice

1. All information included in this document is current as of the date this document is issued. Such information, however, is subject to change without any prior notice. Before purchasing or using any Renesas Electronics products listed herein, please confirm the latest product information with a Renesas Electronics sales office. Also, please pay regular and careful attention to additional and different information to be disclosed by Renesas Electronics such as that disclosed through our website.
2. Renesas Electronics does not assume any liability for infringement of patents, copyrights, or other intellectual property rights of third parties by or arising from the use of Renesas Electronics products or technical information described in this document. No license, express, implied or otherwise, is granted hereby under any patents, copyrights or other intellectual property rights of Renesas Electronics or others.
3. You should not alter, modify, copy, or otherwise misappropriate any Renesas Electronics product, whether in whole or in part.
4. Descriptions of circuits, software and other related information in this document are provided only to illustrate the operation of semiconductor products and application examples. You are fully responsible for the incorporation of these circuits, software, and information in the design of your equipment. Renesas Electronics assumes no responsibility for any losses incurred by you or third parties arising from the use of these circuits, software, or information.
5. When exporting the products or technology described in this document, you should comply with the applicable export control laws and regulations and follow the procedures required by such laws and regulations. You should not use Renesas Electronics products or the technology described in this document for any purpose relating to military applications or use by the military, including but not limited to the development of weapons of mass destruction. Renesas Electronics products and technology may not be used for or incorporated into any products or systems whose manufacture, use, or sale is prohibited under any applicable domestic or foreign laws or regulations.
6. Renesas Electronics has used reasonable care in preparing the information included in this document, but Renesas Electronics does not warrant that such information is error free. Renesas Electronics assumes no liability whatsoever for any damages incurred by you resulting from errors in or omissions from the information included herein.
7. Renesas Electronics products are classified according to the following three quality grades: “Standard”, “High Quality”, and “Specific”. The recommended applications for each Renesas Electronics product depends on the product’s quality grade, as indicated below. You must check the quality grade of each Renesas Electronics product before using it in a particular application. You may not use any Renesas Electronics product for any application categorized as “Specific” without the prior written consent of Renesas Electronics. Further, you may not use any Renesas Electronics product for any application for which it is not intended without the prior written consent of Renesas Electronics. Renesas Electronics shall not be in any way liable for any damages or losses incurred by you or third parties arising from the use of any Renesas Electronics product for an application categorized as “Specific” or for which the product is not intended where you have failed to obtain the prior written consent of Renesas Electronics. The quality grade of each Renesas Electronics product is “Standard” unless otherwise expressly specified in a Renesas Electronics data sheets or data books, etc.
 - “Standard”: Computers; office equipment; communications equipment; test and measurement equipment; audio and visual equipment; home electronic appliances; machine tools; personal electronic equipment; and industrial robots.
 - “High Quality”: Transportation equipment (automobiles, trains, ships, etc.); traffic control systems; anti-disaster systems; anti-crime systems; safety equipment; and medical equipment not specifically designed for life support.
 - “Specific”: Aircraft; aerospace equipment; submersible repeaters; nuclear reactor control systems; medical equipment or systems for life support (e.g. artificial life support devices or systems), surgical implantations, or healthcare intervention (e.g. excision, etc.), and any other applications or purposes that pose a direct threat to human life.
8. You should use the Renesas Electronics products described in this document within the range specified by Renesas Electronics, especially with respect to the maximum rating, operating supply voltage range, movement power voltage range, heat radiation characteristics, installation and other product characteristics. Renesas Electronics shall have no liability for malfunctions or damages arising out of the use of Renesas Electronics products beyond such specified ranges.
9. Although Renesas Electronics endeavors to improve the quality and reliability of its products, semiconductor products have specific characteristics such as the occurrence of failure at a certain rate and malfunctions under certain use conditions. Further, Renesas Electronics products are not subject to radiation resistance design. Please be sure to implement safety measures to guard them against the possibility of physical injury, and injury or damage caused by fire in the event of the failure of a Renesas Electronics product, such as safety design for hardware and software including but not limited to redundancy, fire control and malfunction prevention, appropriate treatment for aging degradation or any other appropriate measures. Because the evaluation of microcomputer software alone is very difficult, please evaluate the safety of the final products or system manufactured by you.
10. Please contact a Renesas Electronics sales office for details as to environmental matters such as the environmental compatibility of each Renesas Electronics product. Please use Renesas Electronics products in compliance with all applicable laws and regulations that regulate the inclusion or use of controlled substances, including without limitation, the EU RoHS Directive. Renesas Electronics assumes no liability for damages or losses occurring as a result of your noncompliance with applicable laws and regulations.
11. This document may not be reproduced or duplicated, in any form, in whole or in part, without prior written consent of Renesas Electronics.
12. Please contact a Renesas Electronics sales office if you have any questions regarding the information contained in this document or Renesas Electronics products, or if you have any other inquiries.

(Note 1) “Renesas Electronics” as used in this document means Renesas Electronics Corporation and also includes its majority-owned subsidiaries.

(Note 2) “Renesas Electronics product(s)” means any product developed or manufactured by or for Renesas Electronics.



User's Manual

μ PD789052, 789062 Subseries

8-Bit Single-Chip Microcontrollers

μ PD789052

μ PD78E9860A

μ PD789062

μ PD78E9861A

Document No. U15861EJ3V1UD00 (3rd edition)

Date Published August 2005 N CP(K)

© NEC Electronics Corporation 2002, 2003
Printed in Japan

[MEMO]

NOTES FOR CMOS DEVICES

① VOLTAGE APPLICATION WAVEFORM AT INPUT PIN

Waveform distortion due to input noise or a reflected wave may cause malfunction. If the input of the CMOS device stays in the area between V_{IL} (MAX) and V_{IH} (MIN) due to noise, etc., the device may malfunction. Take care to prevent chattering noise from entering the device when the input level is fixed, and also in the transition period when the input level passes through the area between V_{IL} (MAX) and V_{IH} (MIN).

② HANDLING OF UNUSED INPUT PINS

Unconnected CMOS device inputs can be cause of malfunction. If an input pin is unconnected, it is possible that an internal input level may be generated due to noise, etc., causing malfunction. CMOS devices behave differently than Bipolar or NMOS devices. Input levels of CMOS devices must be fixed high or low by using pull-up or pull-down circuitry. Each unused pin should be connected to V_{DD} or GND via a resistor if there is a possibility that it will be an output pin. All handling related to unused pins must be judged separately for each device and according to related specifications governing the device.

③ PRECAUTION AGAINST ESD

A strong electric field, when exposed to a MOS device, can cause destruction of the gate oxide and ultimately degrade the device operation. Steps must be taken to stop generation of static electricity as much as possible, and quickly dissipate it when it has occurred. Environmental control must be adequate. When it is dry, a humidifier should be used. It is recommended to avoid using insulators that easily build up static electricity. Semiconductor devices must be stored and transported in an anti-static container, static shielding bag or conductive material. All test and measurement tools including work benches and floors should be grounded. The operator should be grounded using a wrist strap. Semiconductor devices must not be touched with bare hands. Similar precautions need to be taken for PW boards with mounted semiconductor devices.

④ STATUS BEFORE INITIALIZATION

Power-on does not necessarily define the initial status of a MOS device. Immediately after the power source is turned ON, devices with reset functions have not yet been initialized. Hence, power-on does not guarantee output pin levels, I/O settings or contents of registers. A device is not initialized until the reset signal is received. A reset operation must be executed immediately after power-on for devices with reset functions.

⑤ POWER ON/OFF SEQUENCE

In the case of a device that uses different power supplies for the internal operation and external interface, as a rule, switch on the external power supply after switching on the internal power supply. When switching the power supply off, as a rule, switch off the external power supply and then the internal power supply. Use of the reverse power on/off sequences may result in the application of an overvoltage to the internal elements of the device, causing malfunction and degradation of internal elements due to the passage of an abnormal current.

The correct power on/off sequence must be judged separately for each device and according to related specifications governing the device.

⑥ INPUT OF SIGNAL DURING POWER OFF STATE

Do not input signals or an I/O pull-up power supply while the device is not powered. The current injection that results from input of such a signal or I/O pull-up power supply may cause malfunction and the abnormal current that passes in the device at this time may cause degradation of internal elements. Input of signals during the power off state must be judged separately for each device and according to related specifications governing the device.

FIP and EEPROM are trademarks of NEC Electronics Corporation.

Windows and Windows NT are either registered trademarks or trademarks of Microsoft Corporation in the United States and/or other countries.

PC/AT is a trademark of International Business Machines Corporation.

HP9000 series 700 and HP-UX are trademarks of Hewlett-Packard Company.

SPARCstation is a trademark of SPARC International, Inc.

Solaris and SunOS are trademarks of Sun Microsystems, Inc.

These commodities, technology or software, must be exported in accordance with the export administration regulations of the exporting country. Diversion contrary to the law of that country is prohibited.

• **The information in this document is current as of August, 2005. The information is subject to change without notice. For actual design-in, refer to the latest publications of NEC Electronics data sheets or data books, etc., for the most up-to-date specifications of NEC Electronics products. Not all products and/or types are available in every country. Please check with an NEC Electronics sales representative for availability and additional information.**

• No part of this document may be copied or reproduced in any form or by any means without the prior written consent of NEC Electronics. NEC Electronics assumes no responsibility for any errors that may appear in this document.

• NEC Electronics does not assume any liability for infringement of patents, copyrights or other intellectual property rights of third parties by or arising from the use of NEC Electronics products listed in this document or any other liability arising from the use of such products. No license, express, implied or otherwise, is granted under any patents, copyrights or other intellectual property rights of NEC Electronics or others.

• Descriptions of circuits, software and other related information in this document are provided for illustrative purposes in semiconductor product operation and application examples. The incorporation of these circuits, software and information in the design of a customer's equipment shall be done under the full responsibility of the customer. NEC Electronics assumes no responsibility for any losses incurred by customers or third parties arising from the use of these circuits, software and information.

• While NEC Electronics endeavors to enhance the quality, reliability and safety of NEC Electronics products, customers agree and acknowledge that the possibility of defects thereof cannot be eliminated entirely. To minimize risks of damage to property or injury (including death) to persons arising from defects in NEC Electronics products, customers must incorporate sufficient safety measures in their design, such as redundancy, fire-containment and anti-failure features.

• NEC Electronics products are classified into the following three quality grades: "Standard", "Special" and "Specific".

The "Specific" quality grade applies only to NEC Electronics products developed based on a customer-designated "quality assurance program" for a specific application. The recommended applications of an NEC Electronics product depend on its quality grade, as indicated below. Customers must check the quality grade of each NEC Electronics product before using it in a particular application.

"Standard": Computers, office equipment, communications equipment, test and measurement equipment, audio and visual equipment, home electronic appliances, machine tools, personal electronic equipment and industrial robots.

"Special": Transportation equipment (automobiles, trains, ships, etc.), traffic control systems, anti-disaster systems, anti-crime systems, safety equipment and medical equipment (not specifically designed for life support).

"Specific": Aircraft, aerospace equipment, submersible repeaters, nuclear reactor control systems, life support systems and medical equipment for life support, etc.

The quality grade of NEC Electronics products is "Standard" unless otherwise expressly specified in NEC Electronics data sheets or data books, etc. If customers wish to use NEC Electronics products in applications not intended by NEC Electronics, they must contact an NEC Electronics sales representative in advance to determine NEC Electronics' willingness to support a given application.

(Note)

(1) "NEC Electronics" as used in this statement means NEC Electronics Corporation and also includes its majority-owned subsidiaries.

(2) "NEC Electronics products" means any product developed or manufactured by or for NEC Electronics (as defined above).

Regional Information

Some information contained in this document may vary from country to country. Before using any NEC Electronics product in your application, please contact the NEC Electronics office in your country to obtain a list of authorized representatives and distributors. They will verify:

- Device availability
- Ordering information
- Product release schedule
- Availability of related technical literature
- Development environment specifications (for example, specifications for third-party tools and components, host computers, power plugs, AC supply voltages, and so forth)
- Network requirements

In addition, trademarks, registered trademarks, export restrictions, and other legal issues may also vary from country to country.

[GLOBAL SUPPORT]

<http://www.necel.com/en/support/support.html>

NEC Electronics America, Inc. (U.S.)

Santa Clara, California
Tel: 408-588-6000
800-366-9782

NEC Electronics (Europe) GmbH

Duesseldorf, Germany
Tel: 0211-65030

NEC Electronics Hong Kong Ltd.

Hong Kong
Tel: 2886-9318

- **Sucursal en España**

Madrid, Spain
Tel: 091-504 27 87

- **Succursale Française**

Vélizy-Villacoublay, France
Tel: 01-30-67 58 00

- **Filiale Italiana**

Milano, Italy
Tel: 02-66 75 41

- **Branch The Netherlands**

Eindhoven, The Netherlands
Tel: 040-265 40 10

- **Tyskland Filial**

Taeby, Sweden
Tel: 08-63 87 200

- **United Kingdom Branch**

Milton Keynes, UK
Tel: 01908-691-133

NEC Electronics Hong Kong Ltd.

Seoul Branch
Seoul, Korea
Tel: 02-558-3737

NEC Electronics Shanghai Ltd.

Shanghai, P.R. China
Tel: 021-5888-5400

NEC Electronics Taiwan Ltd.

Taipei, Taiwan
Tel: 02-2719-2377

NEC Electronics Singapore Pte. Ltd.

Novena Square, Singapore
Tel: 6253-8311

J05.6

Major Revisions in This Edition

Pages	Description
pp. 22, 23, 30, 31	CHAPTER 1 GENERAL (μPD789052 SUBSERIES) CHAPTER 2 GENERAL (μPD789062 SUBSERIES) <ul style="list-style-type: none"> • Update of 1.5 78K/0S Series Lineup and 2.5 78K/0S Series Lineup to latest version
pp. 60, 61, 62, 64	CHAPTER 5 EEPROM (DATA MEMORY) (μPD78E9860A, 78E9861A ONLY) <ul style="list-style-type: none"> • Deletion of non-selectable clock settings • Addition of Notes to Figure 5-2 Format of EEPROM Write Control Register 10 • Modification of description of (8) in 5.4 Notes for EEPROM Writing
p. 88	CHAPTER 9 8-BIT TIMERS 30 AND 40 <ul style="list-style-type: none"> • Addition of description "output to EEPROM" to Figure 9-2 Block Diagram of Timer 40
p. 144	CHAPTER 14 INTERRUPT FUNCTIONS <ul style="list-style-type: none"> • Modification of a signal name in Figure 14-6 Timing of Non-Maskable Interrupt Request Acknowledgment
pp. 153, 154, 156, 157	CHAPTER 15 STANDBY FUNCTIONS <ul style="list-style-type: none"> • Specification of non-maskable interruption for HALT release in 15.2.1 HALT Mode • Addition of non-maskable interruption for STOP release to 15.2.2 STOP Mode
p. 161	CHAPTER 17 μPD78E9860A, 78E9861A <ul style="list-style-type: none"> • Addition of descriptions of oscillation stabilization time in Table 17-1 Differences Between μPD78E9860A, 78E9861A and Mask ROM Versions • Modification of description of CLK connection in Table 17-3 Pin Connection List
p. 189	CHAPTER 20 ELECTRICAL SPECIFICATIONS <ul style="list-style-type: none"> • Modification of condition of supply currents of μPD78E9860A in DC Characteristics
p. 198	CHAPTER 23 RECOMMENDED SOLDERING CONDITIONS <ul style="list-style-type: none"> • Modification of soldering conditions of μPD789052 and 789062 in Table 23-1 Surface Mounting Type Soldering Conditions
Major revisions in modification version (U15861JE3V1UD00)	
pp. 20, 21, 28, 29	CHAPTER 1 GENERAL (μPD789052 SUBSERIES) CHAPTER 2 GENERAL (μPD789062 SUBSERIES) <ul style="list-style-type: none"> • Addition of lead-free products
p. 199	CHAPTER 23 RECOMMENDED SOLDERING CONDITIONS <ul style="list-style-type: none"> • Addition of soldering conditions of lead-free products in Table 23-1 Surface Mounting Type Soldering Conditions

The mark ★ shows major revised points.

INTRODUCTION

Target Readers

This manual is intended for user engineers who wish to understand the functions of the μ PD789052, 789062 Subseries in order to design and develop its application systems and programs.

The target devices are the following subseries products.

- μ PD789052 Subseries: μ PD789052, 78E9860A
- μ PD789062 Subseries: μ PD789062, 78E9861A

The system clock oscillation frequency of the ceramic/crystal oscillation (μ PD789052 Subseries) is described as f_x and the system clock oscillation frequency of the RC oscillation (μ PD789062 Subseries) is described as f_{cc} .

Purpose

This manual is intended to give users an understanding of the functions described in the **Organization** below.

Organization

Two manuals are available for the μ PD789052, 789062 Subseries: this manual and the Instruction Manual (common to the 78K/0S Series).

μ PD789052, 789062 Subseries User's Manual	78K/0S Series User's Manual Instructions
--	--

- Pin functions
 - Internal block functions
 - Interrupts
 - Other internal peripheral functions
 - Electrical specifications
- CPU function
 - Instruction set
 - Instruction description

How to Use This Manual

It is assumed that the readers of this manual have general knowledge of electrical engineering, logic circuits, and microcontrollers.

To understand the overall functions of the μ PD789052, 789062 Subseries

→ Read this manual in the order of the **CONTENTS**.

How to read register formats

→ The name of a bit whose number is enclosed with $\langle \rangle$ is reserved in the assembler and is defined as an sfr variable by the #pragma sfr directive for the C compiler.

To learn the detailed functions of a register whose register name is known

→ See **APPENDIX C REGISTER INDEX**.

To learn the details of the instruction functions of the 78K/0S Series

→ Refer to **78K/0S Series Instructions User's Manual (U11047E)** separately available.

To learn the electrical specifications of the μ PD789052, 789062 Subseries

→ See **CHAPTER 20 ELECTRICAL SPECIFICATIONS**.

Conventions

Data significance: Higher digits on the left and lower digits on the right
 Active low representation: $\overline{\text{xxx}}$ (overscore over pin or signal name)
Note: Footnote for item marked with **Note** in the text
Caution: Information requiring particular attention
Remark: Supplementary information
 Numerical representation: Binary ... xxxx or xxxxB
 Decimal ... xxx.x
 Hexadecimal ... xxxH

Related Documents

The related documents indicated in this publication may include preliminary versions. However, preliminary versions are not marked as such.

Documents Related to Devices

Document Name	Document No.
μ PD789052, 789062 Subseries User's Manual	This manual
78K/0S Series Instructions User's Manual	U11047E

★ **Documents Related to Development Tools (Software) (User's Manuals)**

Document Name	Document No.	
RA78K0S Assembler Package	Operation	U16656E
	Language	U14877E
	Structured Assembly Language	U11623E
CC78K0S C Compiler	Operation	U16654E
	Language	U14872E
SM78K Series Ver. 2.52 System Simulator	Operation	U16768E
	External Part User Open Interface Specification	U15802E
ID78K0S-NS Ver. 2.52 Integrated Debugger	Operation	U16584E
PM plus Ver.5.10		U16569E

Documents Related to Development Tools (Hardware) (User's Manuals)

Document Name	Document No.
IE-78K0S-NS In-Circuit Emulator	U13549E
IE-78K0S-NS-A In-Circuit Emulator	U15207E
IE-789860-NS-EM1 Emulation Board	U16499E

Caution The related documents listed above are subject to change without notice. Be sure to use the latest version of each document for designing.

Documents Related to Flash Memory Writing

Document Name	Document No.
PG-FP3 Flash Memory Programmer User's Manual	U13502E
PG-FP4 Flash Memory Programmer User's Manual	U15260E

Other Documents

Document Name	Document No.
SEMICONDUCTOR SELECTION GUIDE - Products and Packages -	X13769X
Semiconductor Device Mount Manual	Note
Quality Grades on NEC Semiconductor Devices	C11531E
NEC Semiconductor Device Reliability/Quality Control System	C10983E
Guide to Prevent Damage for Semiconductor Devices by Electrostatic Discharge (ESD)	C11892E

Note See the "Semiconductor Device Mount Manual" website (<http://www.necel.com/pkg/en/mount/index.html>).

Caution The related documents listed above are subject to change without notice. Be sure to use the latest version of each document for designing.

CONTENTS

CHAPTER 1 GENERAL (PD789052 SUBSERIES)	20
1.1 Features	20
1.2 Applications	20
1.3 Ordering Information	20
1.4 Pin Configuration (Top View)	21
1.5 78K/0S Series Lineup	22
1.6 Block Diagram	25
1.7 Overview of Functions	26
CHAPTER 2 GENERAL (PD789062 SUBSERIES)	28
2.1 Features	28
2.2 Applications	28
2.3 Ordering Information	28
2.4 Pin Configuration (Top View)	29
2.5 78K/0S Series Lineup	30
2.6 Block Diagram	33
2.7 Overview of Functions	34
CHAPTER 3 PIN FUNCTIONS	36
3.1 Pin Function List	36
3.2 Description of Pin Functions	37
3.2.1 P00 to P07 (Port 0).....	37
3.2.2 P20, P21 (Port 2).....	37
3.2.3 P40 to P43 (Port 4).....	37
3.2.4 RESET	37
3.2.5 X1, X2 (PD789052 Subseries)	37
3.2.6 CL1, CL2 (PD789062 Subseries)	37
3.2.7 V _{DD}	38
3.2.8 V _{SS}	38
3.2.9 V _{PP} (PD78E9860A, 78E9861A only).....	38
3.2.10 IC (mask ROM version only)	38
3.3 Pin I/O Circuits and Recommended Connection of Unused Pins	39
CHAPTER 4 CPU ARCHITECTURE	40
4.1 Memory Space	40
4.1.1 Internal program memory space.....	42
4.1.2 Internal data memory space	42
4.1.3 Special function register (SFR) area.....	43
4.1.4 Data memory addressing	43
4.2 Processor Registers	45

4.2.1	Control registers	45
4.2.2	General-purpose registers	48
4.2.3	Special function registers (SFRs)	49
4.3	Instruction Address Addressing	51
4.3.1	Relative addressing	51
4.3.2	Immediate addressing	52
4.3.3	Table indirect addressing.....	53
4.3.4	Register addressing.....	53
4.4	Operand Address Addressing	54
4.4.1	Direct addressing.....	54
4.4.2	Short direct addressing.....	55
4.4.3	Special function register (SFR) addressing	56
4.4.4	Register addressing.....	57
4.4.5	Register indirect addressing	58
4.4.6	Based addressing.....	59
4.4.7	Stack addressing.....	59
CHAPTER 5	EEPROM (DATA MEMORY) (PD78E9860A, 78E9861A ONLY).....	60
5.1	Memory Space	60
5.2	EEPROM Configuration	60
5.3	EEPROM Control Register	60
5.4	Notes for EEPROM Writing	63
CHAPTER 6	PORT FUNCTIONS	65
6.1	Port Functions	65
6.2	Port Configuration	65
6.2.1	Port 0.....	66
6.2.2	Port 2.....	67
6.2.3	Port 4.....	68
6.3	Port Function Control Registers	69
6.4	Operation of Port Functions	70
6.4.1	Writing to I/O port	70
6.4.2	Reading from I/O port.....	70
6.4.3	Arithmetic operation of I/O port.....	70
CHAPTER 7	CLOCK GENERATOR (PD789052 SUBSERIES)	71
7.1	Clock Generator Functions	71
7.2	Clock Generator Configuration	71
7.3	Clock Generator Control Register.....	72
7.4	System Clock Oscillators	73
7.4.1	System clock oscillator	73
7.4.2	Examples of incorrect resonator connection.....	74
7.4.3	Frequency divider	75
7.5	Clock Generator Operation	76

7.6	Changing Setting of CPU Clock	77
7.6.1	Time required for switching CPU clock.....	77
7.6.2	Switching CPU clock	77
CHAPTER 8 CLOCK GENERATOR (PD789062 SUBSERIES)		78
8.1	Clock Generator Functions.....	78
8.2	Clock Generator Configuration	78
8.3	Clock Generator Control Register.....	79
8.4	System Clock Oscillators.....	80
8.4.1	System clock oscillator	80
8.4.2	Examples of incorrect resonator connection.....	81
8.4.3	Frequency divider	82
8.5	Clock Generator Operation	83
8.6	Changing Setting of CPU Clock	84
8.6.1	Time required for switching CPU clock.....	84
8.6.2	Switching CPU clock	84
CHAPTER 9 8-BIT TIMERS 30 AND 40.....		85
9.1	8-Bit Timers 30 and 40 Functions.....	85
9.2	8-Bit Timers 30 and 40 Configuration	86
9.3	8-Bit Timers 30 and 40 Control Registers	90
9.4	8-Bit Timers 30 and 40 Operation.....	95
9.4.1	Operation as 8-bit timer counter	95
9.4.2	Operation as 16-bit timer counter	104
9.4.3	Operation as carrier generator.....	111
9.4.4	Operation as PWM output (timer 40 only)	116
9.5	Notes on Using 8-Bit Timers 30 and 40	118
CHAPTER 10 WATCHDOG TIMER		120
10.1	Watchdog Timer Functions.....	120
10.2	Watchdog Timer Configuration	121
10.3	Watchdog Timer Control Registers.....	122
10.4	Watchdog Timer Operation	124
10.4.1	Operation as watchdog timer.....	124
10.4.2	Operation as interval timer	125
CHAPTER 11 POWER-ON-CLEAR CIRCUITS (PD78E9860A, 78E9861A ONLY).....		126
11.1	Power-on-Clear Circuit Functions.....	126
11.2	Power-on-Clear Circuit Configuration	126
11.3	Power-on-Clear Circuit Control Registers.....	128
11.4	Power-on-Clear Circuit Operation	130
11.4.1	Power-on-clear (POC) circuit operation.....	130
11.4.2	Operation of low-voltage detection (LVI) circuit	131

CHAPTER 12 BIT SEQUENTIAL BUFFER	133
12.1 Bit Sequential Buffer Functions	133
12.2 Bit Sequential Buffer Configuration	133
12.3 Bit Sequential Buffer Control Register	134
12.4 Bit Sequential Buffer Operation	135
CHAPTER 13 KEY RETURN CIRCUIT	136
13.1 Key Return Circuit Function	136
13.2 Key Return Circuit Configuration and Operation	136
CHAPTER 14 INTERRUPT FUNCTIONS	137
14.1 Interrupt Function Types	137
14.2 Interrupt Sources and Configuration	137
14.3 Interrupt Function Control Registers	140
14.4 Interrupt Servicing Operation	143
14.4.1 Non-maskable interrupt request acknowledgement operation	143
14.4.2 Maskable interrupt request acknowledgement operation	145
14.4.3 Multiple interrupt servicing	147
14.4.4 Interrupt request pending	149
CHAPTER 15 STANDBY FUNCTION	150
15.1 Standby Function and Configuration	150
15.1.1 Standby function	150
15.1.2 Standby function control register	151
15.2 Standby Function Operation	152
15.2.1 HALT mode	152
15.2.2 STOP mode	155
CHAPTER 16 RESET FUNCTION	158
CHAPTER 17 PD78E9860A, 78E9861A	161
17.1 EEPROM (Program Memory)	162
17.1.1 Programming environment	162
17.1.2 Communication mode	163
17.1.3 On-board pin processing	166
17.1.4 Connection of adapter for flash memory (EEPROM) writing	169
CHAPTER 18 MASK OPTIONS	171
CHAPTER 19 INSTRUCTION SET OVERVIEW	172
19.1 Operation	172
19.1.1 Operand identifiers and description methods	172

19.1.2 Description of “Operation” column.....	173
19.1.3 Description of “Flag” column.....	173
19.2 Operation List.....	174
19.3 Instructions Listed by Addressing Type	179
★ CHAPTER 20 ELECTRICAL SPECIFICATIONS.....	182
★ CHAPTER 21 EXAMPLE OF RC OSCILLATION FREQUENCY CHARACTERISTICS (REFERENCE VALUES)	196
★ CHAPTER 22 PACKAGE DRAWING	197
★ CHAPTER 23 RECOMMENDED SOLDERING CONDITIONS.....	198
APPENDIX A DEVELOPMENT TOOLS.....	200
A.1 Software Package	202
A.2 Language Processing Software	202
A.3 Control Software	203
A.4 EEPROM (Program Memory) Writing Tools	203
A.5 Debugging Tools (Hardware).....	204
A.6 Debugging Tools (Software).....	205
★ APPENDIX B NOTES ON TARGET SYSTEM DESIGN.....	206
APPENDIX C REGISTER INDEX.....	208
C.1 Register Name Index (in Alphabetical Order)	208
C.2 Register Symbol Index (in Alphabetical Order)	209
★ APPENDIX D REVISION HISTORY	210

LIST OF FIGURES (1/3)

Figure No.	Title	Page
3-1	Pin I/O Circuits.....	39
4-1	Memory Map (PD789052, 789062).....	40
4-2	Memory Map (PD78E9860A, 78E9861A).....	41
4-3	Data Memory Addressing (PD789052, 789062).....	43
4-4	Data Memory Addressing (PD78E9860A, 78E9861A).....	44
4-5	Program Counter Configuration.....	45
4-6	Program Status Word Configuration.....	45
4-7	Stack Pointer Configuration.....	47
4-8	Data to Be Saved to Stack Memory.....	47
4-9	Data to Be Restored from Stack Memory.....	47
4-10	General-Purpose Register Configuration.....	48
5-1	EEPROM Block Diagram.....	60
5-2	Format of EEPROM Write Control Register 10.....	61
6-1	Block Diagram of P00 to P07.....	66
6-2	Block Diagram of P20.....	67
6-3	Block Diagram of P21.....	68
6-4	Block Diagram of P40 to P43.....	68
6-5	Format of Port Mode Register.....	69
7-1	Block Diagram of Clock Generator.....	71
7-2	Format of Processor Clock Control Register.....	72
7-3	External Circuit of System Clock Oscillator.....	73
7-4	Example of Incorrect Resonator Connection.....	74
7-5	Switching Between System Clock and CPU Clock.....	77
8-1	Block Diagram of Clock Generator.....	78
8-2	Format of Processor Clock Control Register.....	79
8-3	External Circuit of System Clock Oscillator.....	80
8-4	Example of Incorrect Resonator Connection.....	81
8-5	Switching Between System Clock and CPU Clock.....	84
9-1	Timer 30 Block Diagram.....	87
9-2	Timer 40 Block Diagram.....	88
9-3	Block Diagram of Output Controller (Timer 40).....	89
9-4	Format of 8-Bit Timer Mode Control Register 30.....	91
9-5	Format of 8-Bit Timer Mode Control Register 40.....	92
9-6	Format of Carrier Generator Output Control Register 40.....	93

LIST OF FIGURES (2/3)

Figure No.	Title	Page
9-7	Format of Port Mode Register 2.....	94
9-8	Timing of Interval Timer Operation with 8-Bit Resolution (Basic Operation)	97
9-9	Timing of Interval Timer Operation with 8-Bit Resolution (When CRn0 Is Set to 00H).....	97
9-10	Timing of Interval Timer Operation with 8-Bit Resolution (When CRn0 Is Set to FFH)	98
9-11	Timing of Interval Timer Operation with 8-Bit Resolution (When CRn0 Changes from N to M (N < M))	98
9-12	Timing of Interval Timer Operation with 8-Bit Resolution (When CRn0 Changes from N to M (N > M))	99
9-13	Timing of Interval Timer Operation with 8-Bit Resolution (When Timer 40 Match Signal Is Selected for Timer 30 Count Clock)	100
9-14	Timing of Operation of External Event Counter with 8-Bit Resolution	101
9-15	Timing of Square-Wave Output with 8-Bit Resolution	103
9-16	Timing of Interval Timer Operation with 16-Bit Resolution	106
9-17	Timing of External Event Counter Operation with 16-Bit Resolution	108
9-18	Timing of Square-Wave Output with 16-Bit Resolution	110
9-19	Timing of Carrier Generator Operation (When CR40 = N, CRH40 = M (M > N))	113
9-20	Timing of Carrier Generator Operation (When CR40 = N, CRH40 = M (M < N))	114
9-21	Timing of Carrier Generator Operation (When CR40 = CRH40 = N)	115
9-22	PWM Output Mode Timing (Basic Operation)	117
9-23	PWM Output Mode Timing (When CR40 and CRH40 Are Overwritten)	117
9-24	Case of Error Occurrence of up to 1.5 Clocks	118
9-25	Counting Operation if Timer Is Started When TMI Is High	119
9-26	Timing of Operation as External Event Counter (8-Bit Resolution)	119
10-1	Block Diagram of Watchdog Timer	121
10-2	Format of Timer Clock Selection Register 2	122
10-3	Format of Watchdog Timer Mode Register	123
11-1	Block Diagram of Power-on-Clear Circuit	127
11-2	Block Diagram of Low-Voltage Detection Circuit.....	127
11-3	Format of Power-on-Clear Register 1	128
11-4	Format of Low-Voltage Detection Register 1	129
11-5	Format of Low-Voltage Detection Level Selection Register 1	129
11-6	Timing of Internal Reset Signal Generation in POC Switching Circuit	130
11-7	LVI Circuit Operation Timing.....	132
12-1	Block Diagram of Bit Sequential Buffer	133
12-2	Format of Bit Sequential Buffer Output Control Register 10	134
12-3	Format of Port Mode Register 2.....	134
12-4	Operation Timing of Bit Sequential Buffer.....	135
13-1	Block Diagram of Key Return Circuit.....	136

LIST OF FIGURES (3/3)

Figure No.	Title	Page
13-2	Generation Timing of Key Return Interrupt	136
14-1	Basic Configuration of Interrupt Function	139
14-2	Format of Interrupt Request Flag Register 0	141
14-3	Format of Interrupt Mask Flag Register 0	141
14-4	Program Status Word Configuration	142
14-5	Flowchart from Non-Maskable Interrupt Request Generation to Acknowledgement (INTWDT)	144
14-6	Timing of Non-Maskable Interrupt Request Acknowledgement	144
14-7	Acknowledgement of Non-Maskable Interrupt Request	144
14-8	Interrupt Request Acknowledgement Processing Algorithm	146
14-9	Interrupt Request Acknowledgement Timing (Example of MOV A, r)	147
14-10	Interrupt Request Acknowledgement Timing (When Interrupt Request Flag Is Set at Last Clock During Instruction Execution)	147
14-11	Example of Multiple Interrupts	148
15-1	Format of Oscillation Stabilization Time Selection Register	151
15-2	Releasing HALT Mode by Interrupt	153
15-3	Releasing HALT Mode by $\overline{\text{RESET}}$ Input	154
15-4	Releasing STOP Mode by Interrupt	156
15-5	Releasing STOP Mode by $\overline{\text{RESET}}$ Input	157
16-1	Block Diagram of Reset Function	158
16-2	Reset Timing by $\overline{\text{RESET}}$ Input	159
16-3	Reset Timing by Watchdog Timer Overflow	159
16-4	Reset Timing by $\overline{\text{RESET}}$ Input in STOP Mode	159
17-1	Environment for Writing Program to EEPROM (Program Memory)	162
17-2	Communication Mode Selection Format	163
17-3	Example of Connection with Dedicated Flash Programmer	164
17-4	V _{PP} Pin Connection Example	166
17-5	Signal Conflict (Input Pin of Serial Interface)	167
17-6	Abnormal Operation of Other Device	167
17-7	Signal Conflict ($\overline{\text{RESET}}$ Pin)	168
17-8	Wiring Example for Flash Memory (EEPROM) Writing Adapter with Pseudo 3-Wire	169
A-1	Development Tools	201
B-1	Distance Between In-Circuit Emulator and Conversion Socket	206
B-2	Connection Conditions of Target System	207

LIST OF TABLES (1/2)

Table No.	Title	Page
3-1	Types of Pin I/O Circuits and Recommended Connection of Unused Pins	39
4-1	Internal ROM Capacity.....	42
4-2	Vector Table	42
4-3	Special Function Registers	50
5-1	EEPROM Write Time (When Operating at $f_x = 5.0$ MHz).....	62
5-2	EEPROM Write Time (When Operating at $f_{cc} = 1.0$ MHz).....	62
6-1	Port Functions.....	65
6-2	Configuration of Port	65
6-3	Port Mode Register and Output Latch Settings for Using Alternate Functions.....	69
7-1	Configuration of Clock Generator.....	71
7-2	Maximum Time Required for Switching CPU Clock.....	77
8-1	Configuration of Clock Generator.....	78
8-2	Maximum Time Required for Switching CPU Clock.....	84
9-1	Mode List	85
9-2	Configuration of 8-Bit Timers 30 and 40	86
9-3	Interval Time of Timer 30 (During $f_x = 5.0$ MHz Operation)	96
9-4	Interval Time of Timer 30 (During $f_{cc} = 1.0$ MHz Operation).....	96
9-5	Interval Time of Timer 40 (During $f_x = 5.0$ MHz Operation)	96
9-6	Interval Time of Timer 40 (During $f_{cc} = 1.0$ MHz Operation).....	96
9-7	Square-Wave Output Range of Timer 40 (During $f_x = 5.0$ MHz Operation)	102
9-8	Square-Wave Output Range of Timer 40 (During $f_{cc} = 1.0$ MHz Operation)	102
9-9	Interval Time with 16-Bit Resolution (During $f_x = 5.0$ MHz Operation)	105
9-10	Interval Time with 16-Bit Resolution (During $f_{cc} = 1.0$ MHz Operation)	105
9-11	Square-Wave Output Range with 16-Bit Resolution (During $f_x = 5.0$ MHz Operation).....	109
9-12	Square-Wave Output Range with 16-Bit Resolution (During $f_{cc} = 1.0$ MHz Operation).....	109
10-1	Inadvertent Program Loop Detection Time of Watchdog Timer	120
10-2	Interval Time of Watchdog Timer.....	120
10-3	Configuration of Watchdog Timer	121
10-4	Inadvertent Program Loop Detection Time of Watchdog Timer	124
10-5	Interval Time of Watchdog Timer.....	125
12-1	Configuration of Bit Sequential Buffer	133

LIST OF TABLES (2/2)

Table No.	Title	Page
14-1	Interrupt Sources	138
14-2	Interrupt Request Signals and Corresponding Flags	140
14-3	Time from Generation of Maskable Interrupt Request to Servicing.....	145
15-1	Operation Statuses in HALT Mode	152
15-2	Operation After Releasing HALT Mode.....	154
15-3	Operation Statuses in STOP Mode.....	155
15-4	Operation After Releasing STOP Mode	157
16-1	Status of Hardware After Reset	160
17-1	Differences Between PD78E9860A, 78E9861A and Mask ROM Versions.....	161
17-2	Communication Mode List	163
17-3	Pin Connection List.....	165
19-1	Operand Identifiers and Description Methods.....	172
23-1	Surface Mounting Type Soldering Conditions	198
B-1	Distance Between IE System and Conversion Socket.....	206

CHAPTER 1 GENERAL (μ PD789052 SUBSERIES)

1.1 Features

- ROM and RAM capacity

Product Name \ Item	Program Memory (ROM)		Data Memory	
			Internal High-Speed RAM	EEPROM™
μ PD789052	Mask ROM	4 KB	128 bytes	–
μ PD78E9860A	EEPROM	4 KB		32 bytes

- System clock: Ceramic/crystal oscillation
- Minimum instruction execution time can be changed from high-speed (0.4 μ s) to low-speed (1.6 μ s) at 5.0 MHz operation with system clock.
- I/O ports: 14
- Timer: 3 channels
 - 8-bit timer: 2 channels
 - Watchdog timer: 1 channel
- On-chip power-on-clear circuit (μ PD78E9860A only)
- On-chip bit sequential buffer
- Power supply voltage
 - μ PD789052: $V_{DD} = 1.8$ to 5.5 V
 - μ PD78E9860A: $V_{DD} = 1.8$ to 5.5 V
- Operating ambient temperature: $T_A = -40$ to $+85^\circ\text{C}$

1.2 Applications

TPMS (Tire Pressure Monitoring Systems) and other automotive electrical equipment.

1.3 Ordering Information

	Part Number	Package	Internal ROM
	μ PD789052MC-xxx-5A4	20-pin plastic SSOP (7.62 mm (300))	Mask ROM
	μ PD78E9860AMC-5A4	20-pin plastic SSOP (7.62 mm (300))	EEPROM
★	μ PD789052MC-xxx-5A4-A	20-pin plastic SSOP (7.62 mm (300))	Mask ROM
★	μ PD78E9860AMC-5A4-A	20-pin plastic SSOP (7.62 mm (300))	EEPROM

Remarks 1. xxx indicates ROM code suffix.

2. Products that have the part numbers suffixed by "-A" are lead-free products.

1.4 Pin Configuration (Top View)

20-pin plastic SSOP (7.62 mm (300))

- ★ μ PD789052MC-xxx-5A4 μ PD789052MC-xxx-5A4-A
- ★ μ PD78E9860AMC-5A4 μ PD78E9860AMC-5A4-A

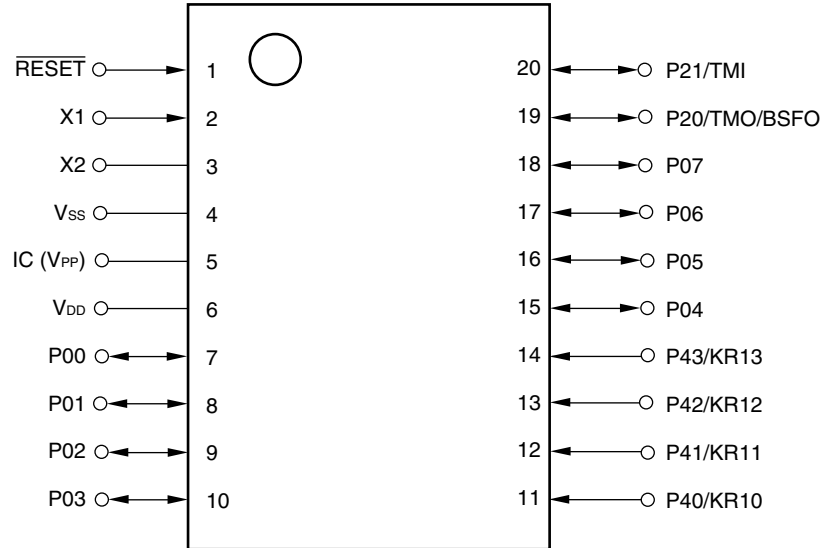

Caution Connect the IC (Internally Connected) pin directly to Vss.

Remark Pin connections in parentheses are intended for the μ PD78E9860A.

BSFO:	Bit sequential buffer output	TMI:	Timer input
IC:	Internally connected	TMO:	Timer output
KR10 to KR13:	Key return	VDD:	Power supply
P00 to P07:	Port 0	VPP:	Programming power supply
P20, P21:	Port 2	Vss:	Ground
P40 to P43:	Port 4	X1, X2:	Crystal/ceramic oscillator
$\overline{\text{RESET}}$:	Reset		

★ 1.5 78K/0S Series Lineup

The products in the 78K/0S Series are listed below. The names enclosed in boxes are subseries names.

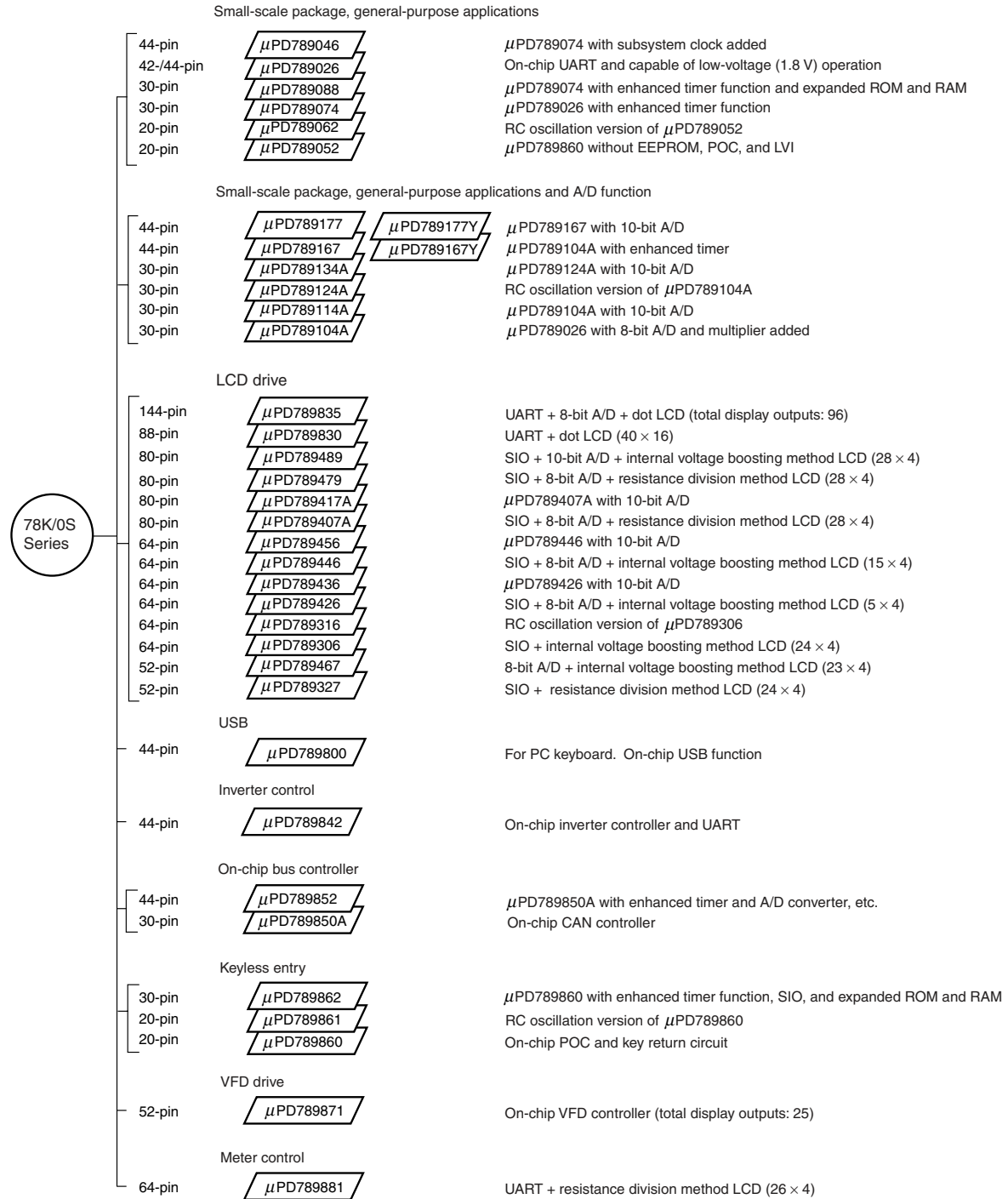
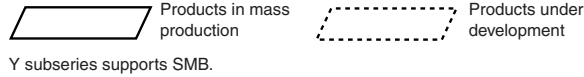

Remark VFD (Vacuum Fluorescent Display) is referred to as FIP™ (Fluorescent Indicator Panel) in some documents, but the functions of the two are the same.

The major differences between subseries are shown below.

Series for General-Purpose and LCD Drive

Subseries		Function	ROM Capacity (Bytes)	Timer				8-Bit A/D	10-Bit A/D	Serial Interface	I/O	V _{DD}	Remarks
				8-Bit	16-Bit	Watch	WDT					MIN.Value	
Small-scale package, general-purpose applications	μ PD789046	16 K	1 ch	1 ch	1 ch	1 ch	–	–	1 ch (UART: 1 ch)	34	1.8 V	–	
	μ PD789026	4 K to 16 K			–					24			
	μ PD789088	16 K to 32 K	3 ch										
	μ PD789074	2 K to 8 K	1 ch										
	μ PD789062	4 K	2 ch	–					–	14		RC-oscillation version	
μ PD789052												–	
Small-scale package, general-purpose applications + A/D converter	μ PD789177	16 K to 24 K	3 ch	1 ch	1 ch	1ch	–	8 ch	1 ch (UART: 1 ch)	31	1.8 V	–	
	μ PD789167						8 ch	–					
	μ PD789134A	2 K to 8 K	1 ch		–		–	4 ch		20		RC-oscillation version	
	μ PD789124A						4 ch	–					
	μ PD789114A						–	4 ch				–	
μ PD789104A						4 ch	–						
LCD drive	μ PD789835	24 K to 60 K	6 ch	–	1 ch	1 ch	3 ch	–	1 ch (UART: 1 ch)	37	1.8 V ^{Note}	Dot LCD supported	
	μ PD789830	24 K	1 ch	1 ch			–			30	2.7 V		
	μ PD789489	32 K to 48 K	3 ch					8 ch	2 ch (UART: 1 ch)	45	1.8 V	–	
	μ PD789479	24 K to 48 K					8 ch	–					
	μ PD789417A	12 K to 24 K					–	7 ch	1 ch (UART: 1 ch)	43			
	μ PD789407A						7 ch	–					
	μ PD789456	12 K to 16 K	2 ch				–	6 ch		30			
	μ PD789446						6 ch	–					
	μ PD789436						–	6 ch		40			
	μ PD789426						6 ch	–					
	μ PD789316	8 K to 16 K					–		2 ch (UART: 1 ch)	23		RC-oscillation version	
	μ PD789306											–	
	μ PD789467	4 K to 24 K		–			1 ch		–	18			
μ PD789327						–		1 ch	21				

Note Flash memory version: 3.0 V

Series for ASSP

Function Subseries Name		ROM Capacity (Bytes)	Timer				8-Bit A/D	10-Bit A/D	Serial Interface	I/O	V _{DD}	Remarks
			8-Bit	16-Bit	Watch	WDT					MIN. Value	
USB	μ PD789800	8 KB	2 ch	–	–	1 ch	–	–	2 ch (USB: 1 ch)	31	4.0 V	–
Inverter control	μ PD789842	8 KB to 16 KB	3 ch	Note 1	1 ch	1 ch	8 ch	–	1 ch (UART: 1 ch)	30	4.0 V	–
On-chip bus controller	μ PD789852	24 KB to 32 KB	3 ch	1 ch	–	1 ch	–	8 ch	3 ch (UART: 2 ch)	31	4.0 V	–
	μ PD789850A	16 KB	1 ch				4 ch	–	2 ch (UART: 1 ch)			
Keyless entry	μ PD789861	4 KB	2 ch	–	–	1 ch	–	–	–	14	1.8 V	RC oscillation version, on-chip EEPROM
	μ PD789860								–			On-chip EEPROM
	μ PD789862	16 KB	1 ch	2 ch	–	–	–	–	1 ch (UART: 1 ch)	22	–	
VFD drive	μ PD789871	4 KB to 8 KB	3 ch	–	1 ch	1 ch	–	–	1 ch	33	2.7 V	–
Meter control	μ PD789881	16 KB	2 ch	1 ch	–	1 ch	–	–	1 ch (UART: 1 ch)	28	2.7 V ^{Note 2}	–

- Notes**
- 10-bit timer: 1 channel
 - Flash memory version: 3.0 V

1.6 Block Diagram

(1) μ PD789052

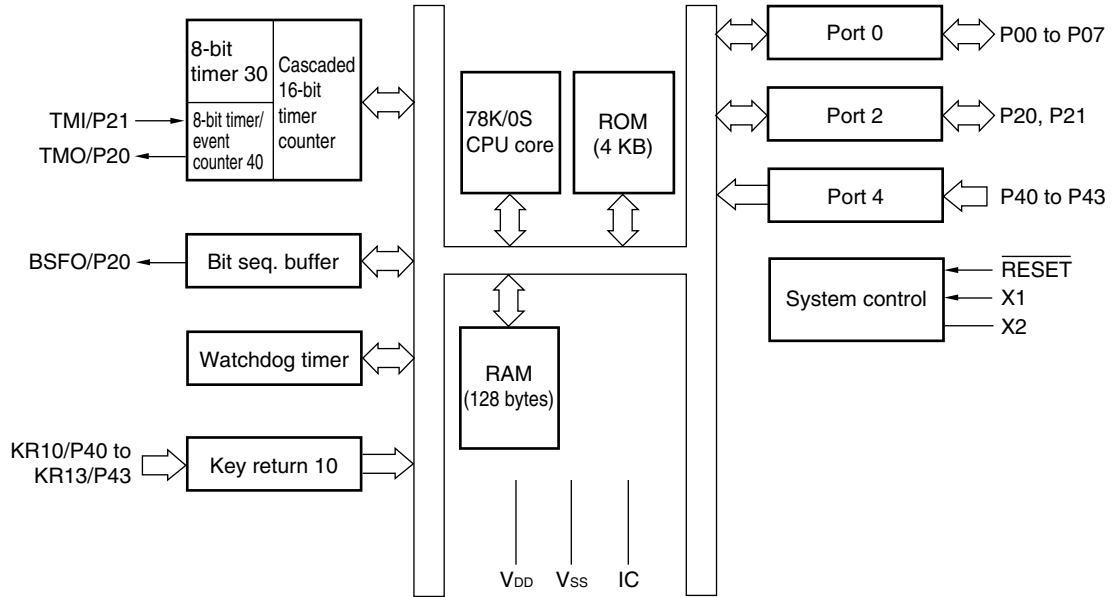

(2) μ PD78E9860A

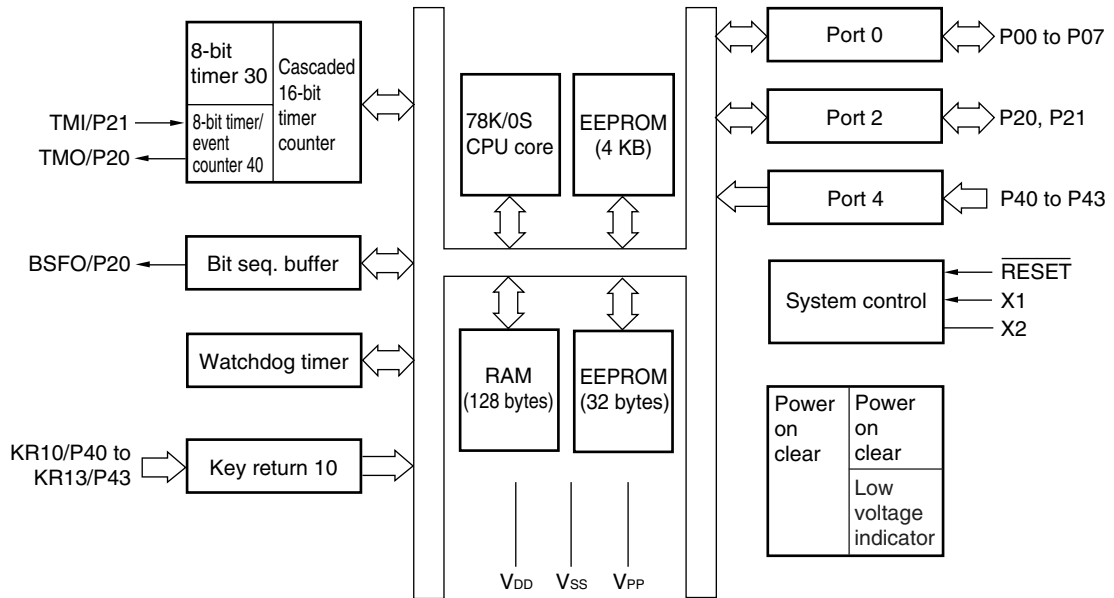

1.7 Overview of Functions

Part Number		μ PD789052	μ PD78E9860A
Item			
Internal memory	ROM	Mask ROM 4 KB	EEPROM
	High-speed RAM	128 bytes	
	EEPROM	–	32 bytes
Oscillator		Ceramic/crystal oscillator	
Minimum instruction execution time		0.4/1.6 μ s (@5.0 MHz operation with system clock)	
General-purpose registers		8 bits \times 8 registers	
Instruction set		<ul style="list-style-type: none"> • 16-bit operations • Bit manipulations (such as set, reset, and test) 	
I/O ports		Total: 14 CMOS I/O: 10 CMOS input: 4	
Timers		<ul style="list-style-type: none"> • 8-bit timer: 2 channels • Watchdog timer: 1 channel 	
Power-on-clear circuit	POC circuit	–	Generates internal reset signal according to comparison of detection voltage to power supply voltage
	LVI circuit	–	Generates interrupt request signal according to comparison of detection voltage to power supply voltage
Bit sequential buffer		8 bits + 8 bits = 16 bits	
Key return function		Generates key return signal according to falling edge detection	
Vectored interrupt sources	Maskable	Internal: 3	Internal: 5
	Non-maskable	Internal: 1, external: 1	
Power supply voltage		$V_{DD} = 1.8$ to 5.5 V	
Operating ambient temperature		$T_A = -40$ to +85°C	
Package		20-pin plastic SSOP (7.62 mm (300))	

An outline of the timer is shown below.

		8-Bit Timer 30	8-Bit Timer 40	Watchdog Timer
Operation mode	Interval timer	1 channel	1 channel	1 channel ^{Note}
	External event counter	–	1 channel	–
Function	Timer outputs	1 output	1 output	–
	PWM outputs	–	1 output	–
	Square-wave outputs	–	1 output	–
	Buzzer outputs	–	–	–
	Capture	–	–	–
	Interrupt sources	1	1	2

Note The watchdog timer has the watchdog timer and interval timer functions. However, use the watchdog timer by selecting either the watchdog timer function or interval timer function.

CHAPTER 2 GENERAL (μ PD789062 SUBSERIES)

2.1 Features

- ROM and RAM capacity

Product Name	Item	Program Memory (ROM)		Data Memory	
				Internal High-Speed RAM	EEPROM
μ PD789062	Mask ROM	4 KB	128 bytes	–	
μ PD78E9861A	EEPROM	4 KB		32 bytes	

- System clock: Ceramic/crystal oscillation
- Minimum instruction execution time can be changed from high-speed (2.0 μ s) to low-speed (8.0 μ s) at 1.0 MHz operation with system clock.
- I/O ports: 14
- Timer: 3 channels
 - 8-bit timer: 2 channels
 - Watchdog timer: 1 channel
- On-chip power-on-clear circuit (μ PD78E9861A only)
- On-chip bit sequential buffer
- Power supply voltage: $V_{DD} = 1.8$ to 3.6 V
- Operating ambient temperature: $T_A = -40$ to $+85^\circ\text{C}$

2.2 Applications

TPMS (Tire Pressure Monitoring Systems) and other automotive electrical equipment.

★ 2.3 Ordering Information

Part Number	Package	Internal ROM
μ PD789062MC-xxx-5A4	20-pin plastic SSOP (7.62 mm (300))	Mask ROM
μ PD78E9861AMC-5A4	20-pin plastic SSOP (7.62 mm (300))	EEPROM
μ PD789062MC-xxx-5A4-A	20-pin plastic SSOP (7.62 mm (300))	Mask ROM
μ PD78E9861AMC-5A4-A	20-pin plastic SSOP (7.62 mm (300))	EEPROM

- Remarks**
1. xxx indicates ROM code suffix.
 2. Products that have the part numbers suffixed by "-A" are lead-free products.

2.4 Pin Configuration (Top View)

20-pin plastic SSOP (7.62 mm (300))

- ★ μ PD789062MC-xxx-5A4 μ PD789062MC-xxx-5A4-A
- ★ μ PD78E9861AMC-5A4 μ PD78E9861AMC-5A4-A

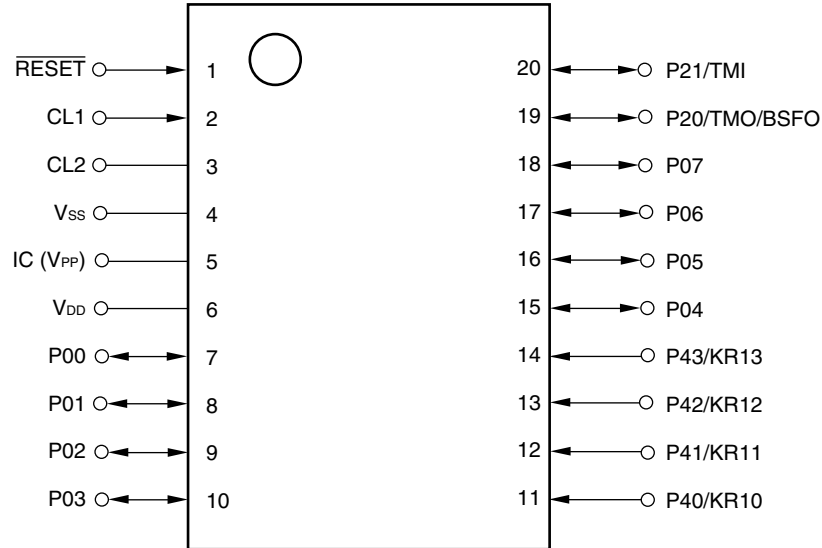

Caution Connect the IC (Internally Connected) pin directly to Vss.

Remark Pin connections in parentheses are intended for the μ PD78E9861A.

BSFO:	Bit sequential buffer output	$\overline{\text{RESET}}$:	Reset
CL1, CL2:	RC oscillator	TMI:	Timer input
IC:	Internally connected	TMO:	Timer output
KR10 to KR13:	Key return	VDD:	Power supply
P00 to P07:	Port 0	VPP:	Programming power supply
P20, P21:	Port 2	Vss:	Ground
P40 to P43:	Port 4		

★ 2.5 78K/0S Series Lineup

The products in the 78K/0S Series are listed below. The names enclosed in boxes are subseries names.

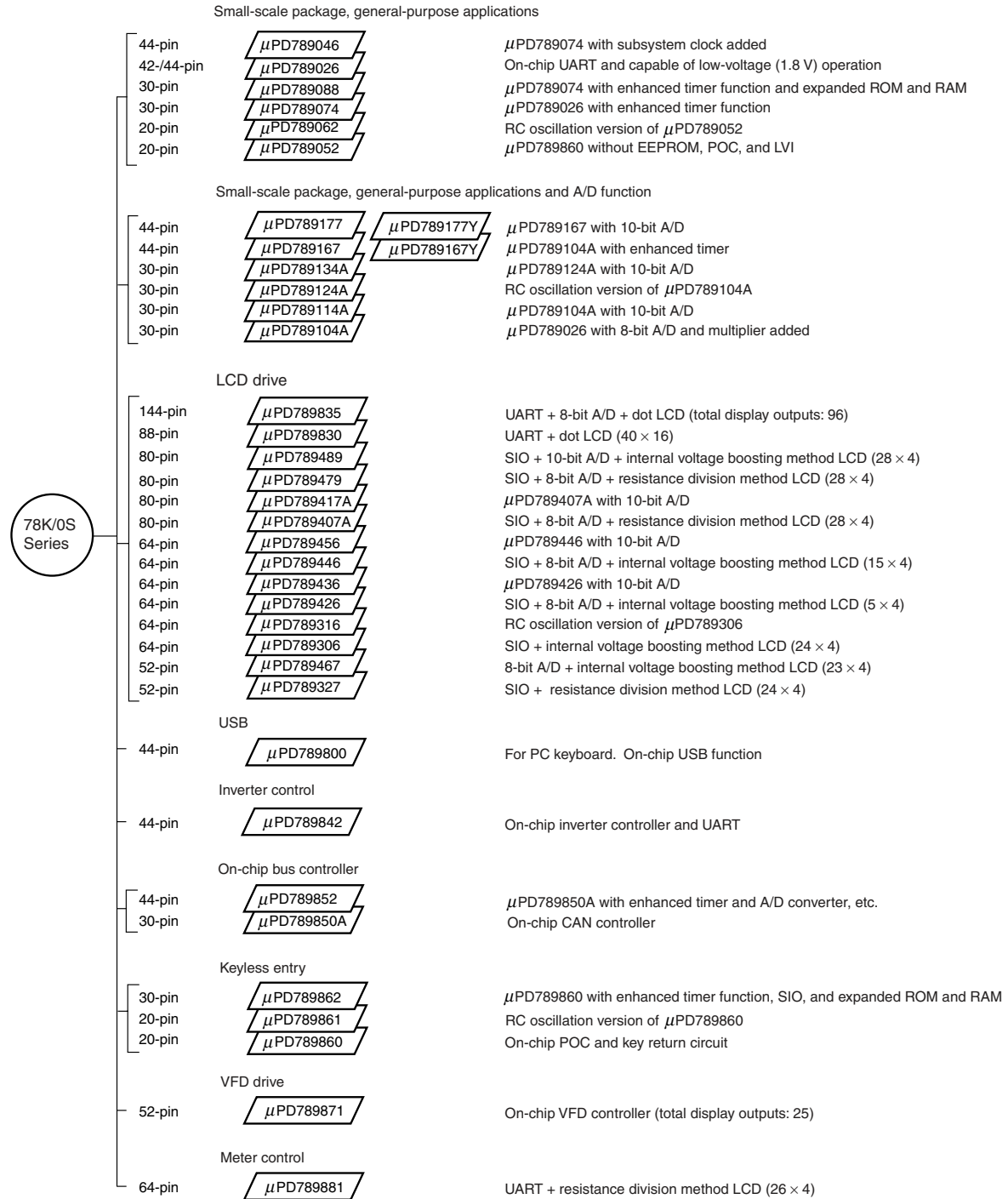
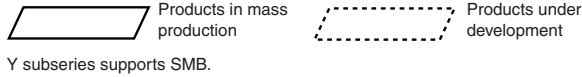

Remark VFD (Vacuum Fluorescent Display) is referred to as FIP (Fluorescent Indicator Panel) in some documents, but the functions of the two are the same.

The major differences between subseries are shown below.

Series for General-Purpose and LCD Drive

Subseries		Function	ROM Capacity (Bytes)	Timer				8-Bit A/D	10-Bit A/D	Serial Interface	I/O	V _{DD}	Remarks
				8-Bit	16-Bit	Watch	WDT					MIN.Value	
Small-scale package, general-purpose applications	μ PD789046	16 K	1 ch	1 ch	1 ch	1 ch	–	–	1 ch (UART: 1 ch)	34	1.8 V	–	
	μ PD789026	4 K to 16 K											
	μ PD789088	16 K to 32 K	3 ch							24			
	μ PD789074	2 K to 8 K	1 ch										
	μ PD789062	4 K	2 ch	–					–	14		RC-oscillation version	
	μ PD789052											–	
Small-scale package, general-purpose applications + A/D converter	μ PD789177	16 K to 24 K	3 ch	1 ch	1 ch	1ch	–	8 ch	1 ch (UART: 1 ch)	31	1.8 V	–	
	μ PD789167						8 ch	–					
	μ PD789134A	2 K to 8 K	1 ch				–	4 ch		20		RC-oscillation version	
	μ PD789124A						4 ch	–					
	μ PD789114A						–	4 ch				–	
	μ PD789104A					4 ch	–						
LCD drive	μ PD789835	24 K to 60 K	6 ch	–	1 ch	1 ch	3 ch	–	1 ch (UART: 1 ch)	37	1.8 V ^{Note}	Dot LCD supported	
	μ PD789830	24 K	1 ch	1 ch			–			30	2.7 V		
	μ PD789489	32 K to 48 K	3 ch					8 ch	2 ch (UART: 1 ch)	45	1.8 V	–	
	μ PD789479	24 K to 48 K					8 ch	–					
	μ PD789417A	12 K to 24 K					–	7 ch	1 ch (UART: 1 ch)	43			
	μ PD789407A						7 ch	–					
	μ PD789456	12 K to 16 K	2 ch				–	6 ch		30			
	μ PD789446						6 ch	–					
	μ PD789436						–	6 ch		40			
	μ PD789426						6 ch	–					
	μ PD789316	8 K to 16 K					–		2 ch (UART: 1 ch)	23		RC-oscillation version	
	μ PD789306											–	
	μ PD789467	4 K to 24 K		–			1 ch		–	18			
μ PD789327						–		1 ch	21				

Note Flash memory version: 3.0 V

Series for ASSP

Function Subseries Name		ROM Capacity (Bytes)	Timer				8-Bit A/D	10-Bit A/D	Serial Interface	I/O	V _{DD}	Remarks
			8-Bit	16-Bit	Watch	WDT					MIN. Value	
USB	μPD789800	8 KB	2 ch	–	–	1 ch	–	–	2 ch (USB: 1 ch)	31	4.0 V	–
Inverter control	μPD789842	8 KB to 16 KB	3 ch	Note 1	1 ch	1 ch	8 ch	–	1 ch (UART: 1 ch)	30	4.0 V	–
On-chip bus controller	μPD789852	24 KB to 32 KB	3 ch	1 ch	–	1 ch	–	8 ch	3 ch (UART: 2 ch)	31	4.0 V	–
	μPD789850A	16 KB	1 ch				4 ch	–	2 ch (UART: 1 ch)			
Keyless entry	μPD789861	4 KB	2 ch	–	–	1 ch	–	–	–	14	1.8 V	RC oscillation version, on-chip EEPROM
	μPD789860								–			On-chip EEPROM
	μPD789862	16 KB	1 ch	2 ch	–	–	–	–	1 ch (UART: 1 ch)	22	–	
VFD drive	μPD789871	4 KB to 8 KB	3 ch	–	1 ch	1 ch	–	–	1 ch	33	2.7 V	–
Meter control	μPD789881	16 KB	2 ch	1 ch	–	1 ch	–	–	1 ch (UART: 1 ch)	28	2.7 V ^{Note 2}	–

Notes 1. 10-bit timer: 1 channel

2. Flash memory version: 3.0 V

2.6 Block Diagram

(1) μ PD789062

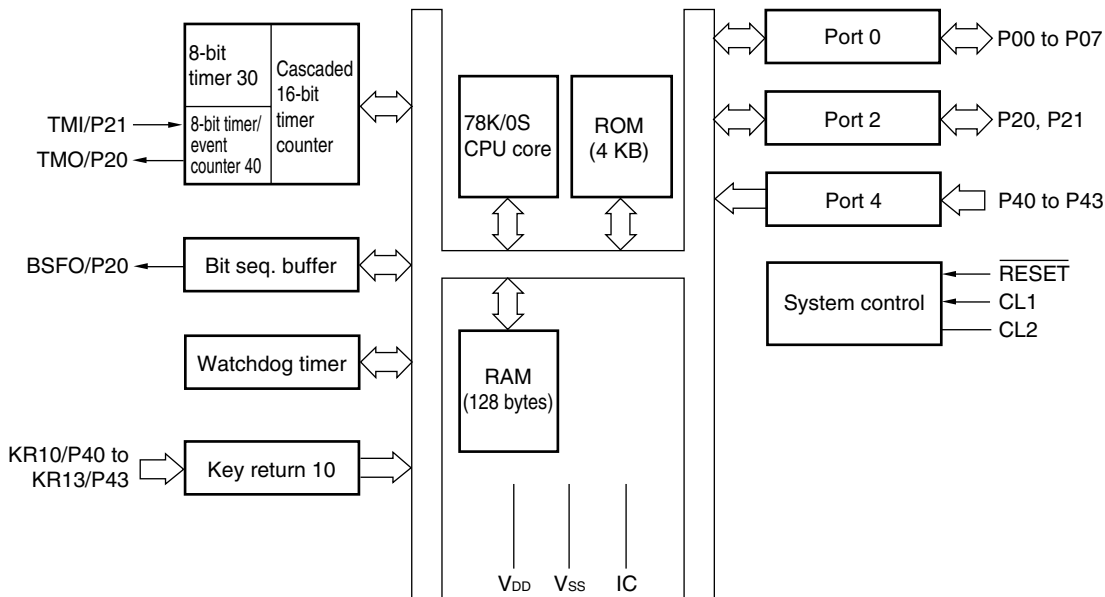

(2) μ PD78E9861A

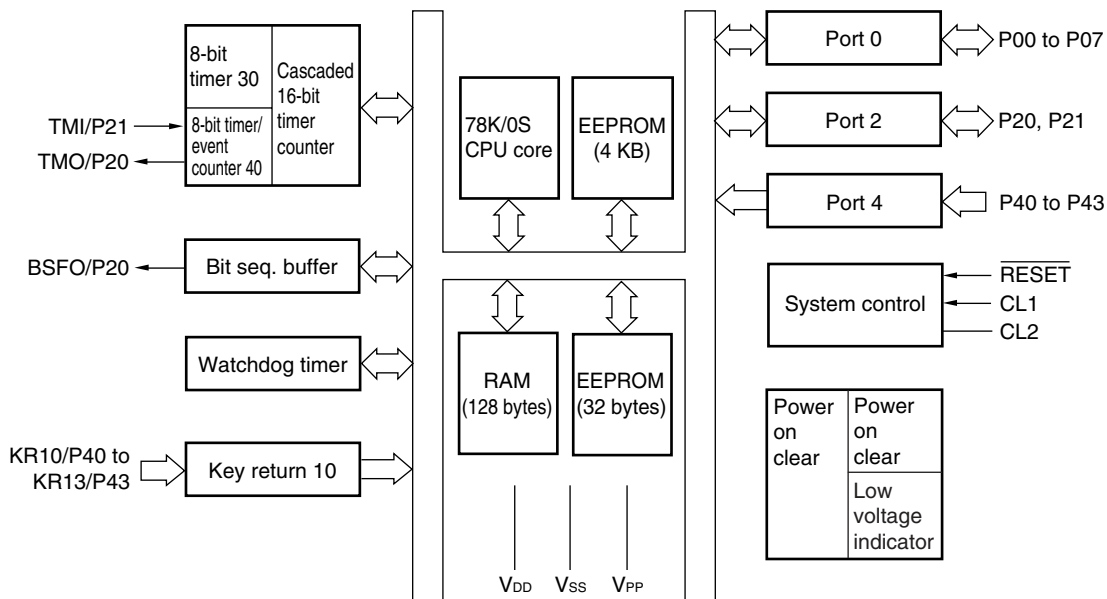

2.7 Overview of Functions

Part Number		μ PD789062	μ PD78E9861A
Item			
Internal memory	ROM	Mask ROM	EEPROM
		4 KB	
	High-speed RAM	128 bytes	
	EEPROM	–	32 bytes
Oscillator		RC oscillator	
Minimum instruction execution time		2.0/8.0 μ s (@ 1.0 MHz operation with system clock)	
General-purpose registers		8 bits \times 8 registers	
Instruction set		<ul style="list-style-type: none"> • 16-bit operations • Bit manipulations (such as set, reset, and test) 	
I/O ports		Total: 14 CMOS I/O: 10 CMOS input: 4	
Timers		<ul style="list-style-type: none"> • 8-bit timer: 2 channels • Watchdog timer: 1 channel 	
Power-on-clear circuit	POC circuit	–	Generates internal reset signal according to comparison of detection voltage to power supply voltage
	LVI circuit	–	Generates interrupt request signal according to comparison of detection voltage to power supply voltage
Bit sequential buffer		8 bits + 8 bits = 16 bits	
Key return function		Generates key return signal according falling edge detection	
Vectored interrupt sources	Maskable	Internal: 3	Internal: 5
	Non-maskable	Internal: 1, external: 1	
Power supply voltage		$V_{DD} = 1.8$ to 3.6 V	
Operating ambient temperature		$T_A = -40$ to $+85^\circ\text{C}$	
Package		20-pin plastic SSOP (7.62 mm (300))	

An outline of the timer is shown below.

		8-Bit Timer 30	8-Bit Timer 40	Watchdog Timer
Operation mode	Interval timer	1 channel	1 channel	1 channel ^{Note}
	External event counter	–	1 channel	–
Function	Timer outputs	1 output	1 output	–
	PWM outputs	–	1 output	–
	Square-wave outputs	–	1 output	–
	Buzzer outputs	–	–	–
	Capture	–	–	–
	Interrupt sources	1	1	2

Note The watchdog timer has the watchdog timer and interval timer functions. However, use the watchdog timer by selecting either the watchdog timer function or interval timer function.

CHAPTER 3 PIN FUNCTIONS

3.1 Pin Function List

(1) Port pins

Pin Name	I/O	Function	After Reset	Alternate Function
P00 to P07	I/O	Port 0 8-bit I/O port Input/output can be specified in 1-bit units.	Input	–
P20	I/O	Port 2 2-bit I/O port Input/output can be specified in 1-bit units.	Input	TMO/BSFO
P21				TMI
P40 to P43	Input	Port 4 4-bit input-only port For mask ROM versions, an on-chip pull-up resistor can be specified by means of the mask option.	Input	KR10 to KR13

(2) Non-port pins

Pin Name	I/O	Function	After Reset	Alternate Function
TMI	Input	8-bit timer (TM40) input	Input	P21
TMO	Output	8-bit timer (TM40) output	Input	P20/BSFO
BSFO	Output	Bit sequential buffer (BSF10) output	Input	P20/TMO
KR10 to KR13	Input	Key return input	Input	P40 to P43
X1 ^{Note 1}	Input	Connecting ceramic/crystal resonator for system clock oscillation	–	–
X2 ^{Note 1}			–	–
CL1 ^{Note 2}	Input	Connecting resistor (R) and capacitor (C) for system clock oscillation	–	–
CL2 ^{Note 2}			–	–
RESET	Input	System reset input	Input	–
V _{DD}	–	Positive supply voltage	–	–
V _{SS}	–	Ground potential	–	–
IC	–	Internally connected. Connect directly to V _{SS} .	–	–
V _{PP}	–	This pin is used to set the EEPROM programming mode and applies a high voltage when a program is written or verified.	–	–

Notes 1. μ PD789052 Subseries only

2. μ PD789062 Subseries only

3.2 Description of Pin Functions

3.2.1 P00 to P07 (Port 0)

These pins constitute an 8-bit I/O port and can be set to input or output port mode in 1-bit units by using port mode register 0 (PM0).

3.2.2 P20, P21 (Port 2)

These pins constitute a 2-bit I/O port. In addition, these pins function as the timer input/output and bit sequential buffer output.

Port 2 can be set to the following operation modes in 1-bit units.

(1) Port mode

In port mode, P20 and P21 function as a 2-bit I/O port. Port 2 can be set to input or output port mode in 1-bit units by using port mode register 2 (PM2).

(2) Control mode

In this mode, P20 and P21 function as the timer input/output and the bit sequential buffer output.

(a) BSFO

This is the output pin of the bit sequential buffer.

(b) TMI

This is the external clock input pin for the timer 40.

(c) TMO

This is the output pin of the timer 40.

3.2.3 P40 to P43 (Port 4)

These pins constitute a 4-bit input-only port. In addition, these pins function as the key return input.

(1) Port mode

In port mode, P40 to P43 function as a 4-bit input-only port. For mask ROM versions, an on-chip pull-up resistor can be specified by means of the mask option.

(2) Control mode

In this mode, P40 to P43 function as the key return input (KR10 to KR13).

3.2.4 $\overline{\text{RESET}}$

An active-low system reset signal is input to this pin.

3.2.5 X1, X2 ($\mu\text{PD789052}$ Subseries)

These pins are used to connect a crystal resonator for system clock oscillation.

To supply an external clock, input the clock to X1 and input the inverted signal to X2.

3.2.6 CL1, CL2 ($\mu\text{PD789062}$ Subseries)

These pins are used to connect a resistor (R) and capacitor (C) for system clock oscillation.

To supply an external clock, input the clock to CL1 and input the inverted signal to CL2.

3.2.7 V_{DD}

This pin supplies positive power.

3.2.8 V_{SS}

This pin is the ground potential pin.

3.2.9 V_{PP} (μ PD78E9860A, 78E9861A only)

A high voltage should be applied to this pin when the EEPROM programming mode is set and when the program is written or verified.

Perform either of the following.

- Independently connect a 10k Ω pull-down resistor to V_{PP}.
- Use the jumper on the board to connect V_{PP} to the dedicated flash programmer or V_{SS}, in programming mode or normal operation mode, respectively.

If the wiring length between the V_{PP} and V_{SS} pins is too long or if external noise is superimposed on the V_{PP} pin, your program may not be executed correctly.

3.2.10 IC (mask ROM version only)

The IC (Internally Connected) pin is used to set the μ PD789052 and 789062 to test mode before shipment. In normal operation mode, directly connect this pin to the V_{SS} pin with as short a wiring length as possible.

If a potential difference is generated between the IC pin and the V_{SS} pin due to a long wiring length between these pins or an external noise superimposed on the IC pin, the user program may not run correctly.

- **Directly connect the IC pin to the V_{SS} pin.**

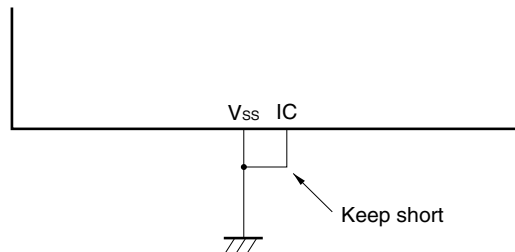

3.3 Pin I/O Circuits and Recommended Connection of Unused Pins

The I/O circuit type of each pin and recommended connection of unused pins are shown in Table 3-1. For the I/O circuit configuration of each type, refer to Figure 3-1.

Table 3-1. Types of Pin I/O Circuits and Recommended Connection of Unused Pins

Pin Name	I/O Circuit Type	I/O	Recommended Connection of Unused Pins
P00 to P07	5	I/O	Input: Independently connect to V_{DD} or V_{SS} via a resistor.
P20/TMO/BSFO			Output: Leave open.
P21/TMI			
P40/KR10 to P43/KR13 (mask ROM version)	2-E	Input	Connect directly to V_{DD} or V_{SS} .
P40/KR10 to P43/KR13 (μ PD78E9860A, 78E9861A)	2		
RESET			
IC	-	-	Connect directly to V_{SS} .
V_{PP}			Independently connect V_{PP} to a 10 k Ω pull-down resistor or directly connect to V_{SS} .

Figure 3-1. Pin I/O Circuits

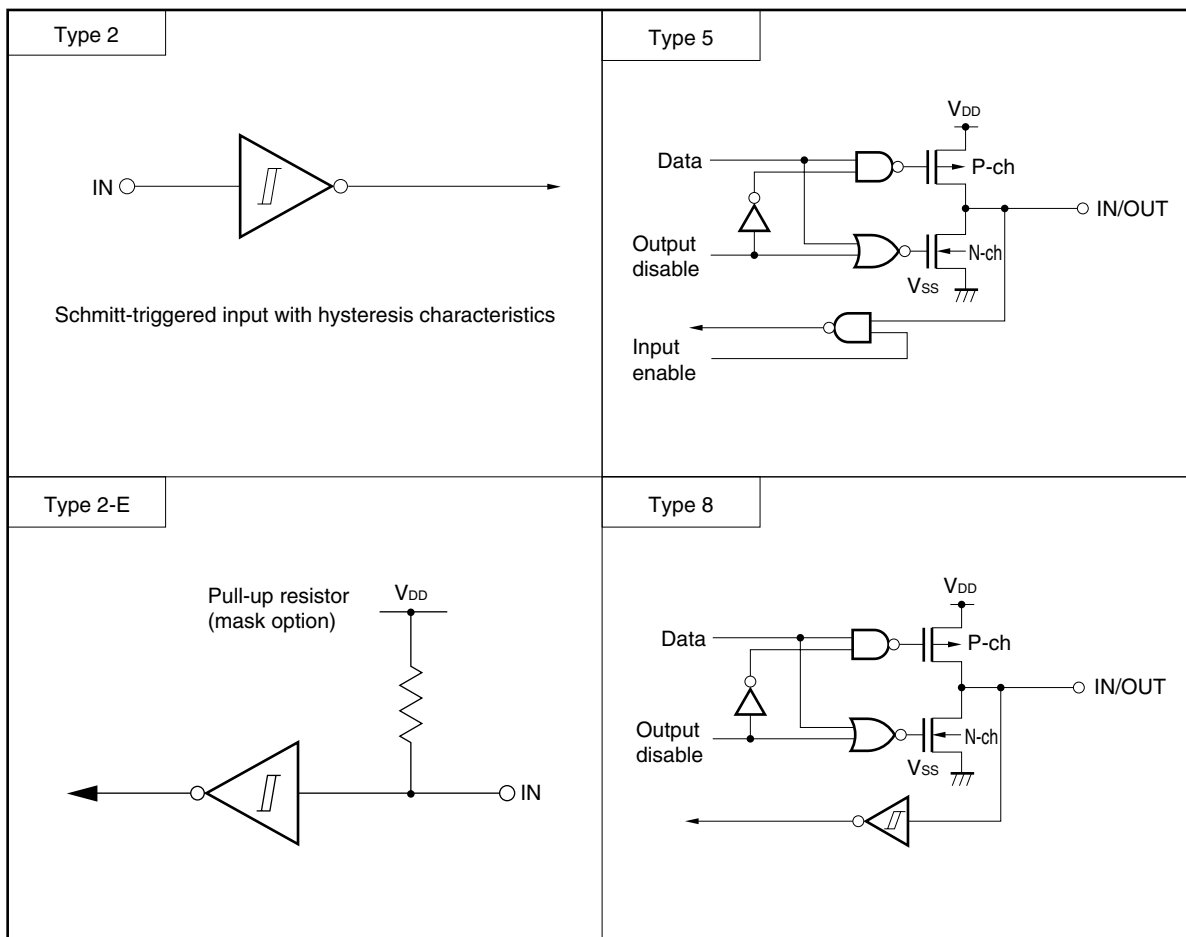

CHAPTER 4 CPU ARCHITECTURE

4.1 Memory Space

The μ PD789052, 789062 Subseries can each access up to 64 KB of memory space. Figures 4-1 and 4-2 show the memory maps.

Figure 4-1. Memory Map (μ PD789052, 789062)

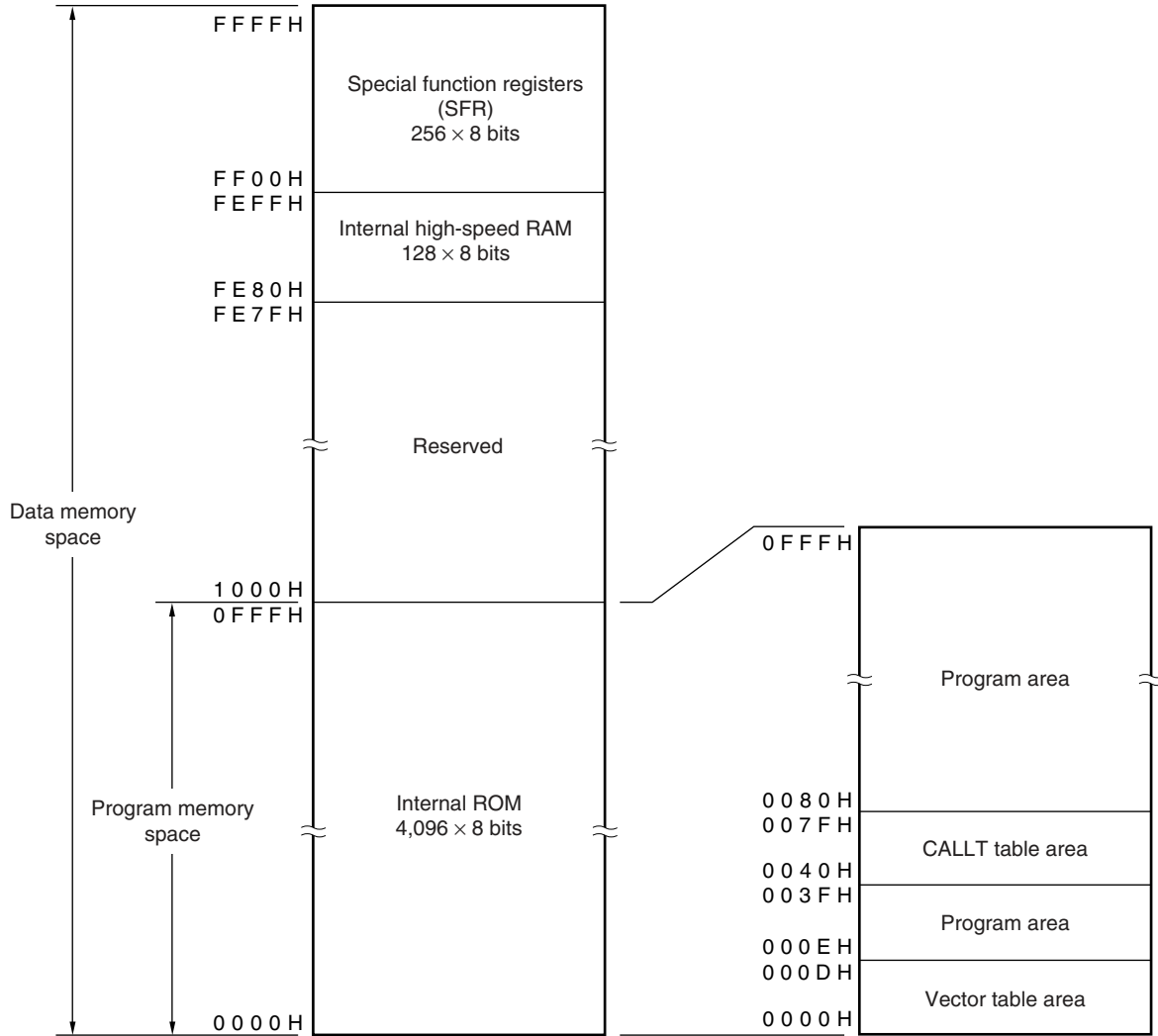
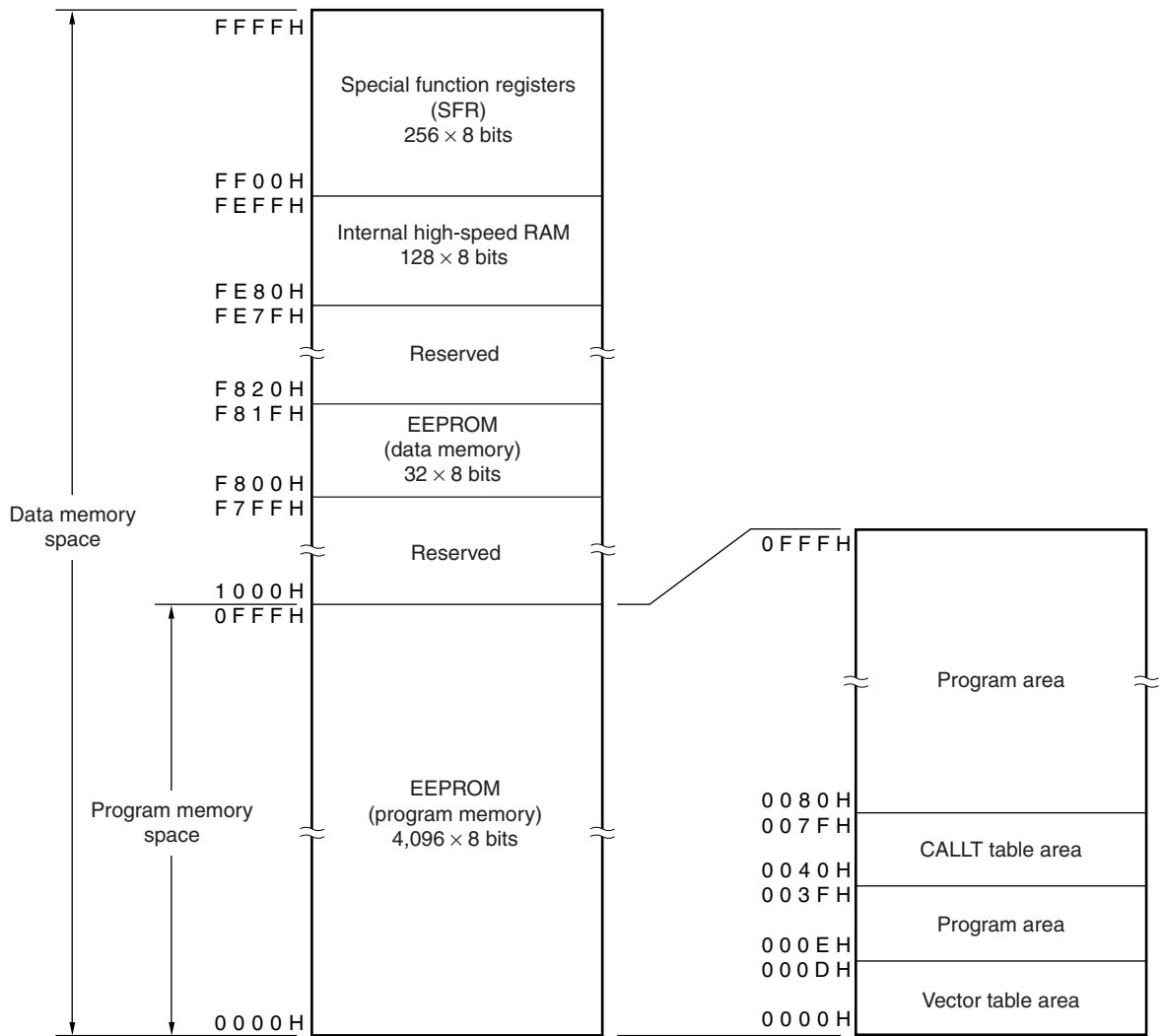

Figure 4-2. Memory Map (μ PD78E9860A, 78E9861A)



4.1.1 Internal program memory space

The internal program memory space stores programs and table data. This space is usually addressed by the program counter (PC).

The μ PD789052, 789062 Subseries provide the following internal ROMs (or EEPROM) containing the following capacities.

Table 4-1. Internal ROM Capacity

Part Number	Internal ROM	
	Structure	Capacity
μ PD789052, 789062	Mask ROM	4,096 \times 8 bits
μ PD78E9860A, 78E9861A	EEPROM	

The following areas are allocated to the internal program memory space:

(1) Vector table area

The 14-byte area of addresses 0000H to 000DH is reserved as a vector table area. This area stores program start addresses to be used when branching by $\overline{\text{RESET}}$ input or interrupt request generation. Of a 16-bit address, the lower 8 bits are stored in an even address, and the higher 8 bits are stored in an odd address.

Table 4-2. Vector Table

Vector Table Address	Interrupt Request	Vector Table Address	Interrupt Request
0000H	$\overline{\text{RESET}}$ input	0008H	INTTM40
0002H	INTKR1	000AH	INTLV11 ^{Note}
0004H	INTWDT	000CH	INTEE0 ^{Note}
0006H	INTTM30		

Note μ PD78E9860A, 78E9861A only

(2) CALLT instruction table area

The subroutine entry address of a 1-byte call instruction (CALLT) can be stored in the 64-byte area of addresses 0040H to 007FH.

4.1.2 Internal data memory space

The μ PD789052, 789062 Subseries provide the following RAMs.

(1) Internal high-speed RAM

The internal high-speed RAM is provided in the area of FE80H to FEFFH.

The internal high-speed RAM can also be used as a stack memory.

(2) EEPROM (μ PD78E9860A, 78E9861A only)

In the μ PD78E9860A, 78E9861A, the EEPROM is provided in the area of F800H to F81FH.

For details of EEPROM, refer to **CHAPTER 5 EEPROM (DATA MEMORY) (μ PD78E9860A, 78E9861A ONLY)**.

4.1.3 Special function register (SFR) area

Special function registers (SFRs) of on-chip peripheral hardware are allocated to the area of FF00H to FFFFH (see **Table 4-3**).

4.1.4 Data memory addressing

Each of the μ PD789052, 789062 Subseries is provided with a wide range of addressing modes to make memory manipulation as efficient as possible. The data memory area (FE80H to FFFFH) can be accessed using a unique addressing mode according to its use, such as a special function register (SFR). Figures 4-3 and 4-4 illustrate the data memory addressing.

Figure 4-3. Data Memory Addressing (μ PD789052, 789062)

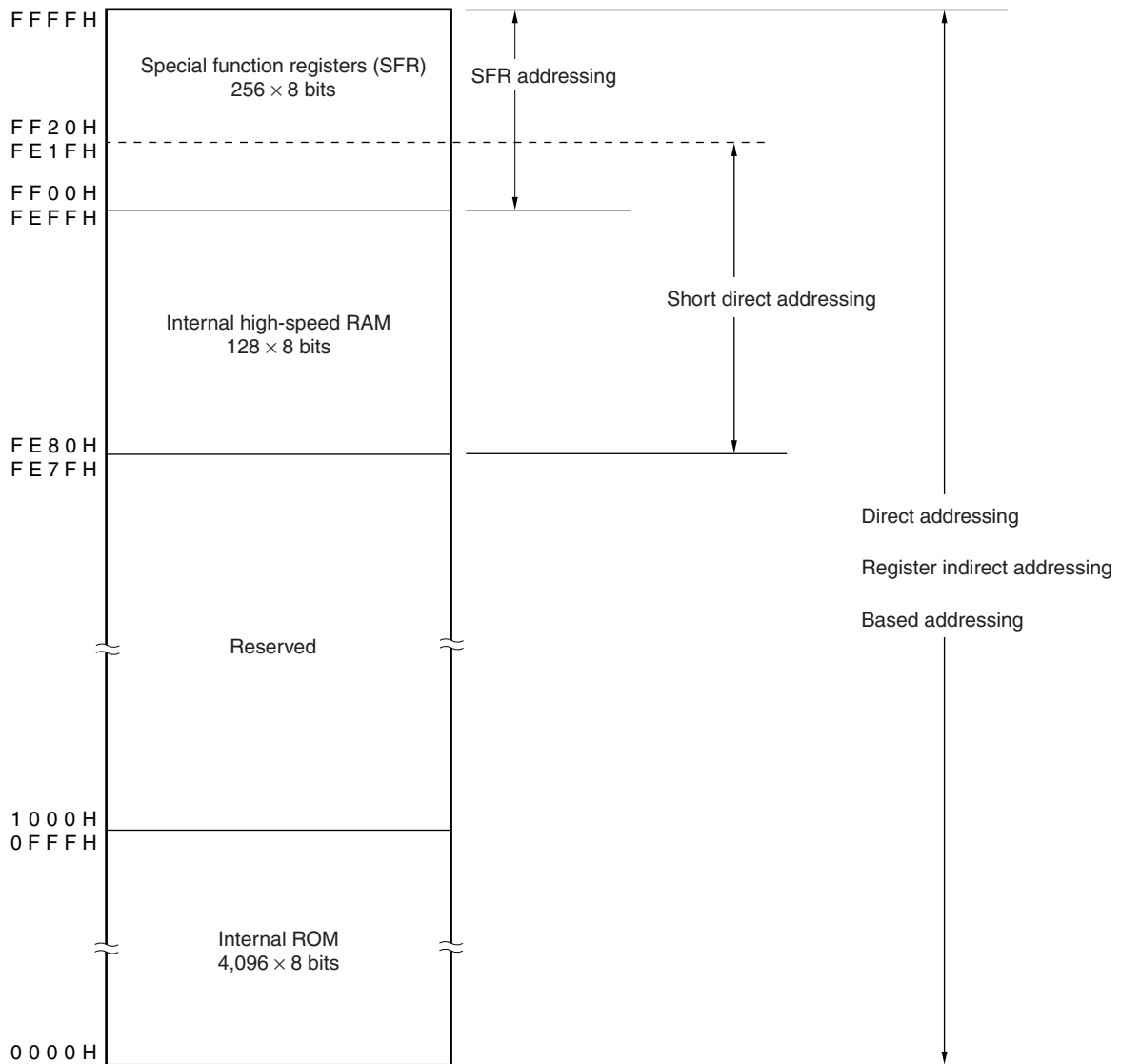
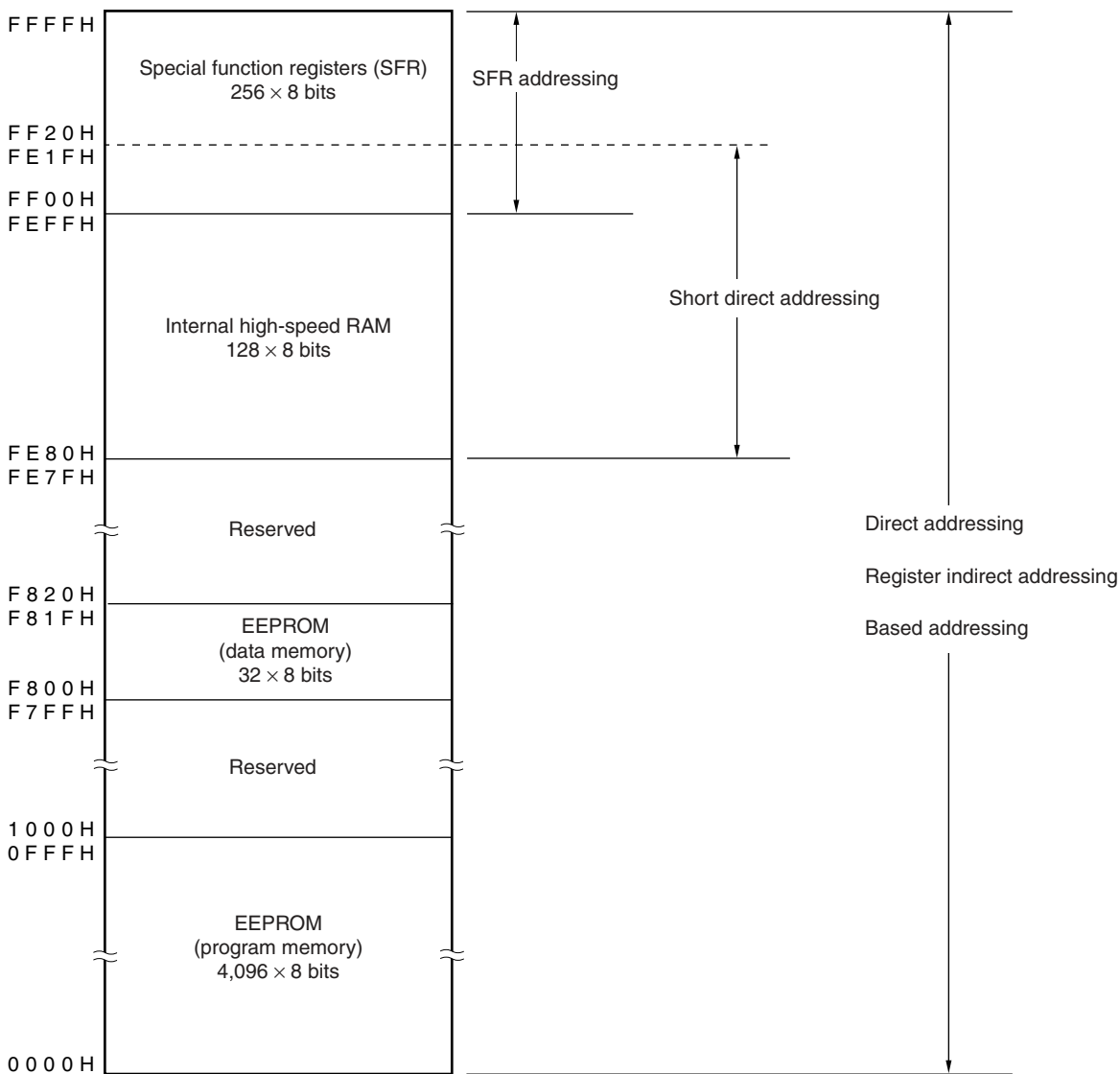

Figure 4-4. Data Memory Addressing (μ PD78E9860A, 78E9861A)



4.2 Processor Registers

The μ PD789052, 789062 Subseries provide the following on-chip processor registers:

4.2.1 Control registers

The control registers have special functions to control the program sequence statuses and stack memory. The control registers include a program counter, a program status word, and a stack pointer.

(1) Program counter (PC)

The program counter is a 16-bit register which holds the address information of the next program to be executed.

In normal operation, the PC is automatically incremented according to the number of bytes of the instruction to be fetched. When a branch instruction is executed, immediate data or register contents are set.

$\overline{\text{RESET}}$ input sets the reset vector table values at addresses 0000H and 0001H to the program counter.

Figure 4-5. Program Counter Configuration

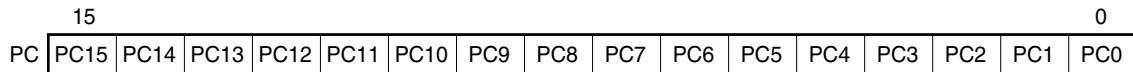

(2) Program status word (PSW)

The program status word is an 8-bit register consisting of various flags to be set/reset by instruction execution.

Program status word contents are automatically stacked upon interrupt request generation or PUSH PSW instruction execution and are automatically restored upon execution of the RETI and POP PSW instructions.

$\overline{\text{RESET}}$ input sets PSW to 02H.

Figure 4-6. Program Status Word Configuration

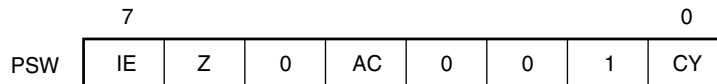

(a) Interrupt enable flag (IE)

This flag controls interrupt request acknowledge operations of the CPU.

When IE = 0, the interrupt disabled (DI) status is set. All interrupt requests except non-maskable interrupt are disabled.

When IE = 1, the interrupt enabled (EI) status is set. Interrupt request acknowledgment is controlled with an interrupt mask flag for various interrupt sources.

This flag is reset to 0 upon DI instruction execution or interrupt acknowledgment and is set to 1 upon EI instruction execution.

(b) Zero flag (Z)

When the operation result is zero, this flag is set to 1. It is reset to 0 in all other cases.

(c) Auxiliary carry flag (AC)

If the operation result has a carry from bit 3 or a borrow at bit 3, this flag is set to 1. It is reset to 0 in all other cases.

(d) Carry flag (CY)

This flag stores overflow and underflow that have occurred upon add/subtract instruction execution. It stores the shift-out value upon rotate instruction execution and functions as a bit accumulator during bit operation instruction execution.

(3) Stack pointer (SP)

This is a 16-bit register to hold the start address of the memory stack area. Only the internal high-speed RAM area can be set as the stack area.

Figure 4-7. Stack Pointer Configuration

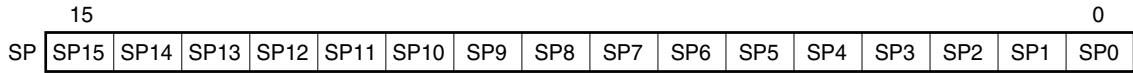

The SP is decremented before writing (saving) to the stack memory and is incremented after reading (restoring) from the stack memory.

Each stack operation saves/restores data as shown in Figures 4-8 and 4-9.

★ **Caution** Since $\overline{\text{RESET}}$ input makes SP contents undefined, be sure to initialize the SP before using the stack.

Figure 4-8. Data to Be Saved to Stack Memory

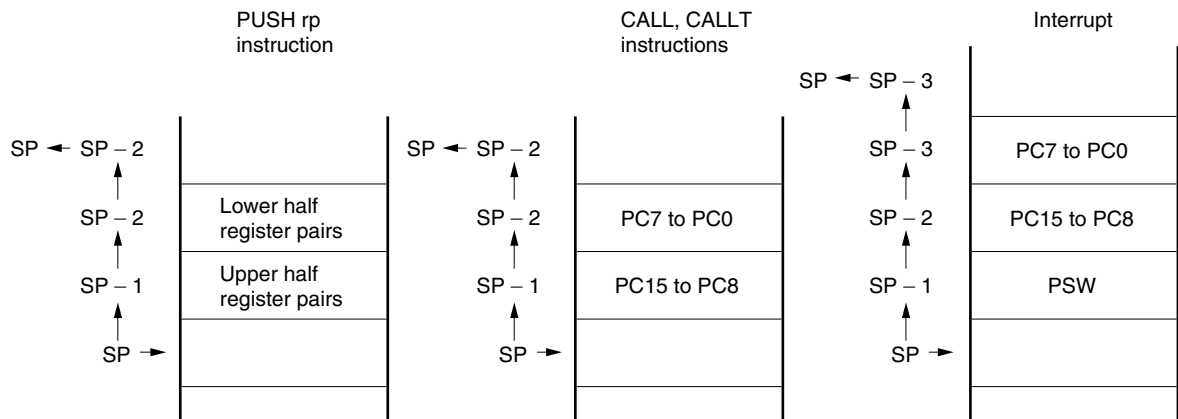
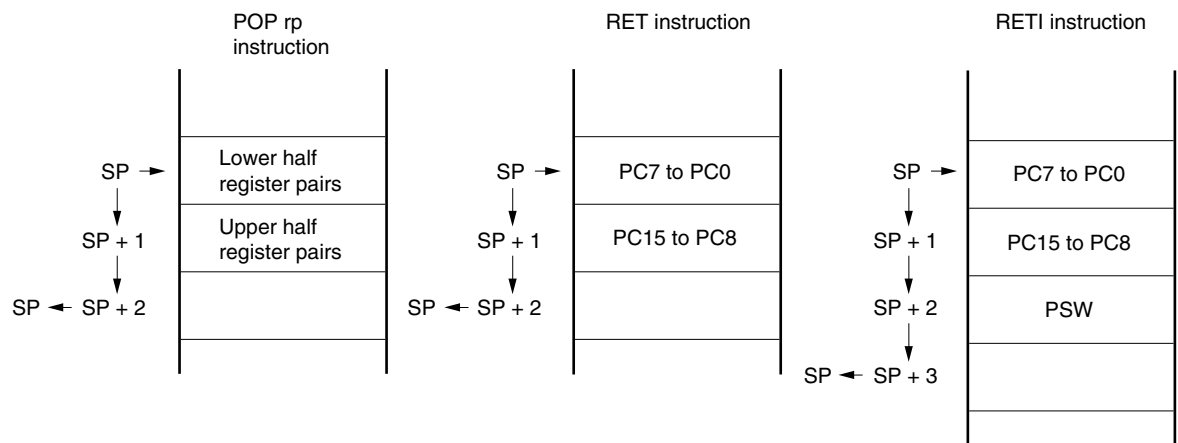

Figure 4-9. Data to Be Restored from Stack Memory



4.2.2 General-purpose registers

A general-purpose register consists of eight 8-bit registers (X, A, C, B, E, D, L, and H).

In addition each register being used as an 8-bit register, two 8-bit registers in pairs can be used as a 16-bit register (AX, BC, DE, and HL).

Registers can be described in terms of function names (X, A, C, B, E, D, L, H, AX, BC, DE, and HL) and absolute names (R0 to R7 and RP0 to RP3).

Figure 4-10. General-Purpose Register Configuration

(a) Absolute names

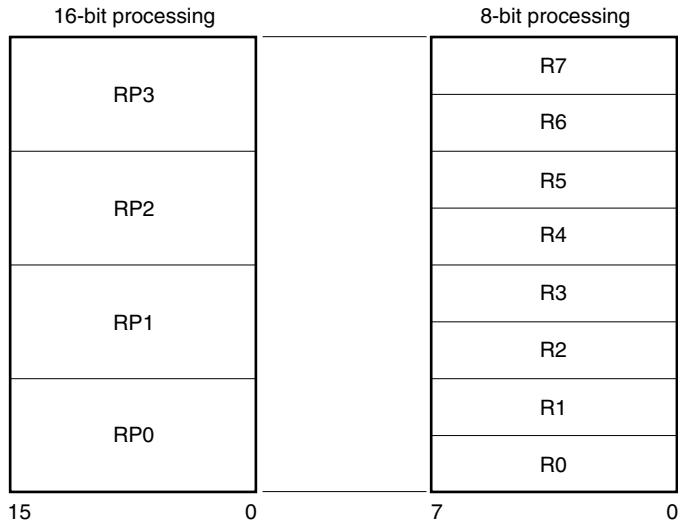

(b) Function names

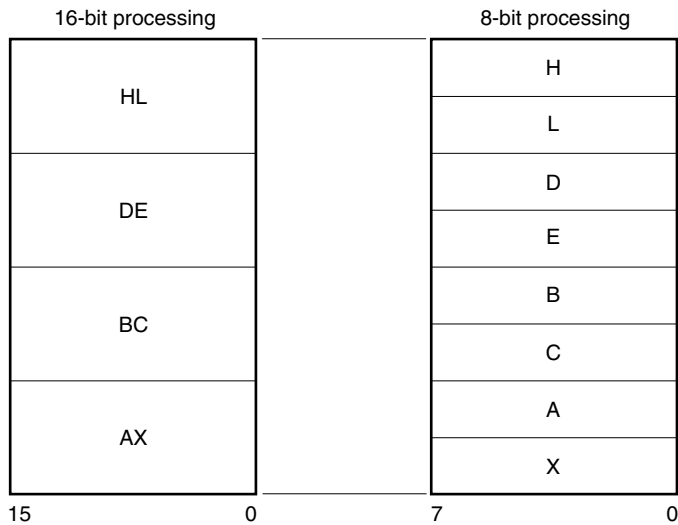

4.2.3 Special function registers (SFRs)

Unlike the general-purpose registers, each special function register has a special function.

The special function registers are allocated to the 256-byte area FF00H to FFFFH.

The special function registers can be manipulated, like the general-purpose registers, with operation, transfer, and bit manipulation instructions. Manipulatable bit units (1, 8, and 16) differ depending on the special function register type.

Each manipulation bit unit can be specified as follows.

- 1-bit manipulation
Describes a symbol reserved by the assembler for the 1-bit manipulation instruction operand (sfr.bit). This manipulation can also be specified with an address.
- 8-bit manipulation
Describes a symbol reserved by the assembler for the 8-bit manipulation instruction operand (sfr). This manipulation can also be specified with an address.
- 16-bit manipulation
Describes a symbol reserved by the assembler for the 16-bit manipulation instruction operand. When specifying an address, describe an even address.

Table 4-3 lists the special function registers. The meanings of the symbols in this table are as follows:

- Symbol
Indicates the addresses of the implemented special function registers. The symbols shown in this column are reserved words in the assembler, and have already been defined as an sfr variable by the #pragma sfr directive for the C compiler. Therefore, these symbols can be used as instruction operands if an assembler or integrated debugger is used.
- R/W
Indicates whether the special function register can be read or written.
R/W: Read/write
R: Read only
W: Write only
- Number of bits manipulated simultaneously
Indicates the bit units (1, 8, and 16) in which the special function register can be manipulated.
- After reset
Indicates the status of the special function register when the $\overline{\text{RESET}}$ signal is input.

Table 4-3. Special Function Registers

Address	Special Function Register (SFR) Name	Symbol	R/W	Number of Bits Manipulated Simultaneously			After Reset	
				1 Bit	8 Bits	16 Bits		
FF00H	Port 0	P0	R/W	√	√	–	00H	
FF02H	Port 2	P2		√	√	–		
FF04H	Port 4	P4	R	√	√	–		
FF10H	Bit sequential buffer 10 data register L	BSFRL10	W	–	√	√ ^{Note 1}	Undefined	
FF11H	Bit sequential buffer 10 data register H	BSFRH10		–	√			
FF20H	Port mode register 0	PM0	R/W	√	√	–	FFH	
FF22H	Port mode register 2	PM2		√	√	–		
FF42H	Timer clock selection register 2	TCL2		–	√	–		
FF50H	8-bit compare register 30	CR30	W	–	√	–	Undefined	
FF51H	8-bit timer counter 30	TM30	R	–	√	–	00H	
FF52H	8-bit timer mode control register 30	TMC30	R/W	√	√	–		
FF53H	8-bit compare register 40	CR40	W	–	√	–	Undefined	
FF54H	8-bit compare register H40	CRH40		–	√	–		
FF55H	8-bit timer counter 40	TM40	R	–	√	–	00H	
FF56H	8-bit timer mode control register 40	TMC40	R/W	√	√	–		
FF57H	Carrier generator output control register 40	TCA40	W	–	√	–		
FF60H	Bit sequential buffer output control register 10	BSFC10	R/W	√	√	–		
FFD8H	EEPROM write control register 10 ^{Note 2}	EEWC10		√	√	–		08H
FFDDH	Power-on-clear register 1 ^{Note 2}	POCF1		√	√	–		00H ^{Note 3}
FFDEH	Low-voltage detection register 1 ^{Note 2}	LVIF1		√	√	–		00H
FFDFH	Low-voltage detection level selection register 1 ^{Note 2}	LVIS1		√	√	–		
FFE0H	Interrupt request flag register 0	IF0		√	√	–		
FFE4H	Interrupt mask flag register 0	MK0		√	√	–	FFH	
FFF9H	Watchdog timer mode register	WDTM	√	√	–	00H		
FFFAH	Oscillation stabilization time selection register ^{Note 4}	OSTS	–	√	–	04H		
FFFBH	Processor clock control register	PCC	√	√	–	02H		

- Notes**
1. Specify address FF10H directly for 16-bit access.
 2. μ PD78E9860A, 78E9861A only
 3. This value is 04H only after a power-on-clear reset.
 4. μ PD789052 Subseries only

4.3 Instruction Address Addressing

An instruction address is determined by the program counter (PC) contents. The PC contents are normally incremented (+1 for each byte) automatically according to the number of bytes of an instruction to be fetched each time another instruction is executed. When a branch instruction is executed, the branch destination address information is set to the PC to branch by the following addressing (for details of each instruction, refer to **78K/0S Series Instructions User's Manual (U11047E)**).

4.3.1 Relative addressing

[Function]

The value obtained by adding 8-bit immediate data (displacement value: *jdisp8*) of an instruction code to the start address of the following instruction is transferred to the program counter (PC) to branch. The displacement value is treated as signed two's complement data (−128 to +127) and bit 7 becomes the sign bit. In other words, the range of branch in relative addressing is between −128 and +127 of the start address of the following instruction.

This function is carried out when the BR \$addr16 instruction or a conditional branch instruction is executed.

[Illustration]

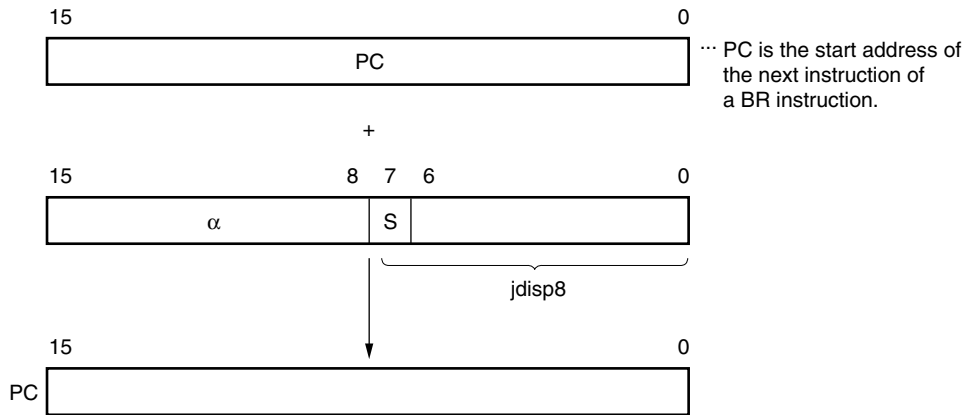

When S = 0, α indicates that all bits are "0".
 When S = 1, α indicates that all bits are "1".

4.3.2 Immediate addressing

[Function]

Immediate data in the instruction word is transferred to the program counter (PC) to branch. This function is carried out when the CALL !addr16 and BR !addr16 instructions are executed. CALL !addr16 and BR !addr16 instructions can be used to branch to all the memory spaces.

[Illustration]

In case of CALL !addr16 and BR !addr16 instructions

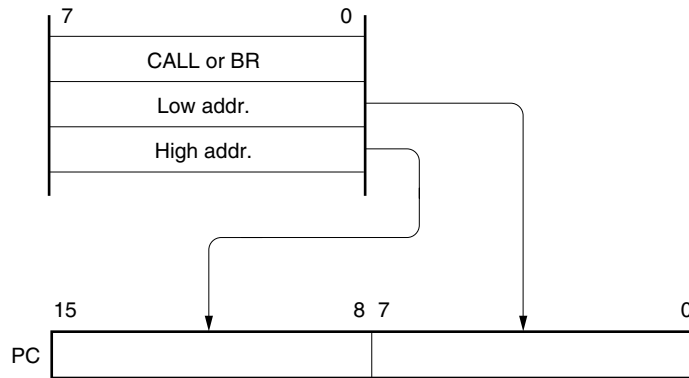

4.3.3 Table indirect addressing

[Function]

The table contents (branch destination address) of the particular location to be addressed by the immediate data of an instruction code from bit 1 to bit 5 are transferred to the program counter (PC) to branch.

Table indirect addressing is carried out when the CALLT [addr5] instruction is executed. This instruction can be used to branch to all the memory spaces according to the address stored in the memory table 40H to 7FH.

[Illustration]

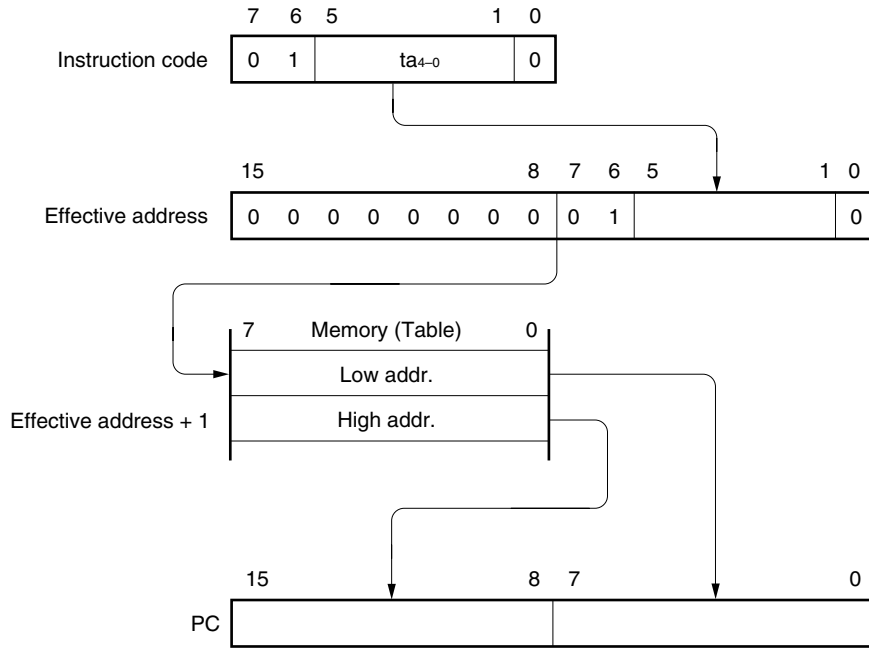

4.3.4 Register addressing

[Function]

The register pair (AX) contents to be specified with an instruction word are transferred to the program counter (PC) to branch.

This function is carried out when the BR AX instruction is executed.

[Illustration]

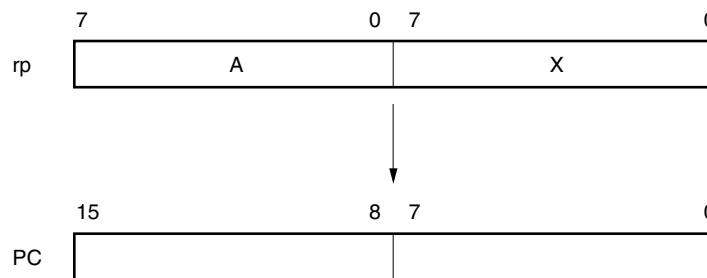

4.4 Operand Address Addressing

The following methods (addressing) are available to specify the register and memory to undergo manipulation during instruction execution.

4.4.1 Direct addressing

[Function]

The memory indicated by immediate data in an instruction word is directly addressed.

[Operand format]

Identifier	Description
addr16	Label or 16-bit immediate data

[Description example]

MOV A, !FE00H; When setting !addr16 to FE00H

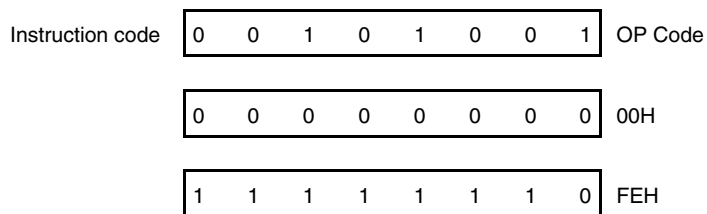

[Illustration]

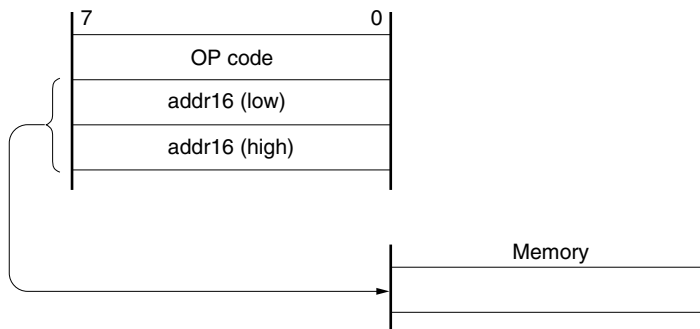

4.4.2 Short direct addressing

[Function]

The memory to be manipulated in the fixed space is directly addressed with the 8-bit data in an instruction word. The fixed space where this addressing is applied is the 256-byte space FE20H to FF1FH. An internal high-speed RAM is mapped at FE20H to FEFFH and the special function registers (SFR) are mapped at FF00H to FF1FH.

The SFR area where short direct addressing is applied (FF00H to FF1FH) is a part of the total SFR area. In this area, ports which are frequently accessed in a program and a compare register of the timer counter are mapped, and these SFRs can be manipulated with a small number of bytes and clocks.

When 8-bit immediate data is at 20H to FFH, bit 8 of an effective address is set to 0. When it is at 00H to 1FH, bit 8 is set to 1. See [Illustration] below.

[Operand format]

Identifier	Description
saddr	Label or FE20H to FF1FH immediate data
saddrp	Label or FE20H to FF1FH immediate data (even address only)

[Description example]

MOV FE90H, #50H; When setting saddr to FE90H and the immediate data to 50H

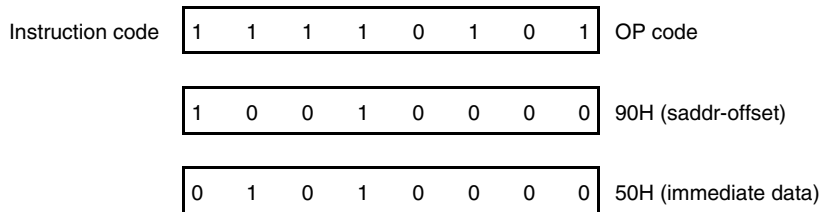

[Illustration]

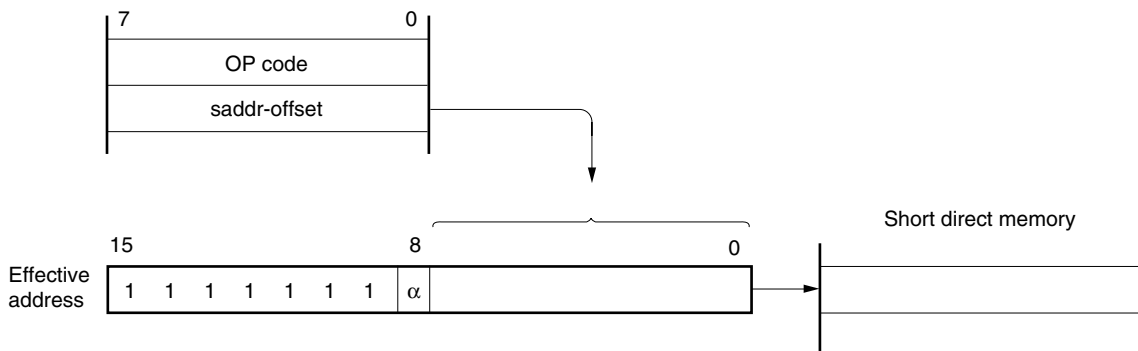

When 8-bit immediate data is 20H to FFH, $\alpha = 0$.
 When 8-bit immediate data is 00H to 1FH, $\alpha = 1$.

4.4.3 Special function register (SFR) addressing

[Function]

A memory-mapped special function register (SFR) is addressed with the 8-bit immediate data in an instruction word.

This addressing is applied to the 256-byte space FF00H to FFFFH. However, SFRs mapped at FF00H to FF1FH can also be accessed with short direct addressing.

[Operand format]

Identifier	Description
sfr	Special function register name

[Description example]

MOV PM0, A; When selecting PM0 for sfr

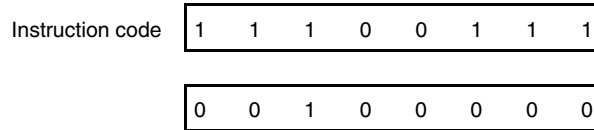

[Illustration]

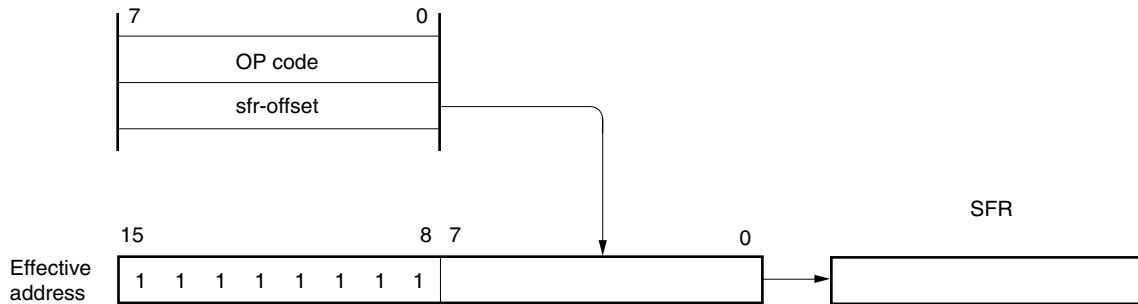

4.4.4 Register addressing

[Function]

A general-purpose register is accessed as an operand.

The general-purpose register to be accessed is specified with the register specify code and functional name in the instruction code.

Register addressing is carried out when an instruction with the following operand format is executed. When an 8-bit register is specified, one of the eight registers is specified with 3 bits in the instruction code.

[Operand format]

Identifier	Description
r	X, A, C, B, E, D, L, H
rp	AX, BC, DE, HL

'r' and 'rp' can be described with absolute names (R0 to R7 and RP0 to RP3) as well as function names (X, A, C, B, E, D, L, H, AX, BC, DE, and HL).

[Description example]

MOV A, C; When selecting the C register for r

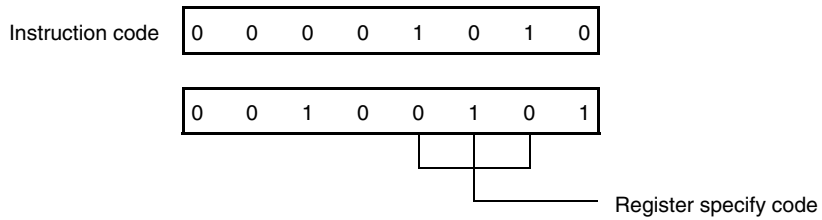

INCW DE; When selecting the DE register pair for rp

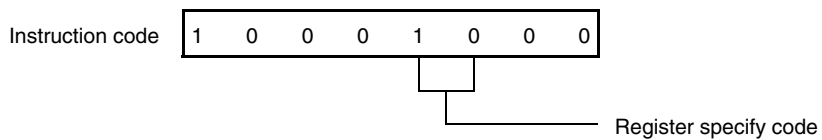

4.4.5 Register indirect addressing

[Function]

The memory is addressed with the contents of the register pair specified as an operand. The register pair to be accessed is specified with the register pair specify code in the instruction code. This addressing can be carried out for all the memory spaces.

[Operand format]

Identifier	Description
-	[DE], [HL]

[Description example]

MOV A, [DE]; When selecting register pair [DE]

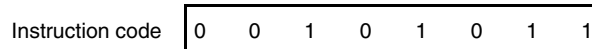

[Illustration]

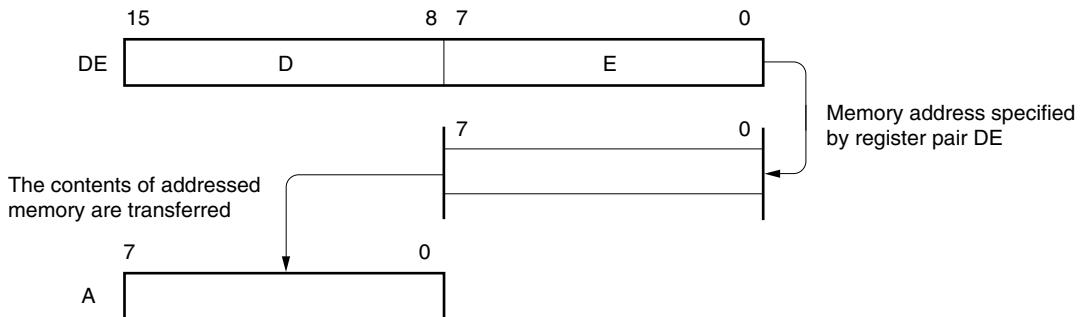

4.4.6 Based addressing

[Function]

8-bit immediate data is added to the contents of the base register, that is, the HL register pair, and the sum is used to address the memory. Addition is performed by expanding the offset data as a positive number to 16 bits. A carry from the 16th bit is ignored. This addressing can be carried out for all the memory spaces.

[Operand format]

Identifier	Description
-	[HL+byte]

[Description example]

MOV A, [HL+10H]; When setting byte to 10H

Instruction code	0 0 1 0 1 1 0 1
	0 0 0 1 0 0 0 0

4.4.7 Stack addressing

[Function]

The stack area is indirectly addressed with the stack pointer (SP) contents. This addressing method is automatically employed when the PUSH, POP, subroutine call, and return instructions are executed or the register is saved/restored upon interrupt request generation. Stack addressing can be used to access the internal high-speed RAM area only.

[Description example]

In the case of PUSH DE

Instruction code	1 0 1 0 1 0 1 0
------------------	-----------------

CHAPTER 5 EEPROM (DATA MEMORY) (μ PD78E9860A, 78E9861A ONLY)

5.1 Memory Space

Besides internal high-speed RAM, the μ PD78E9860A and 78E9861A have 32×8 bits of electrically erasable PROM (EEPROM) on-chip as data memory.

Unlike normal RAM, EEPROM can maintain its contents even if its power supply is cut. In addition, unlike EPROM, its electrical contents can be erased without using ultraviolet rays.

5.2 EEPROM Configuration

EEPROM consists of the EEPROM itself and a control section.

The control section consists of EEPROM write control register 10 (EEWC10) which controls EEPROM writing and a part that detects the termination of writing and generates an interrupt request signal (INTEE0).

★

Figure 5-1. EEPROM Block Diagram

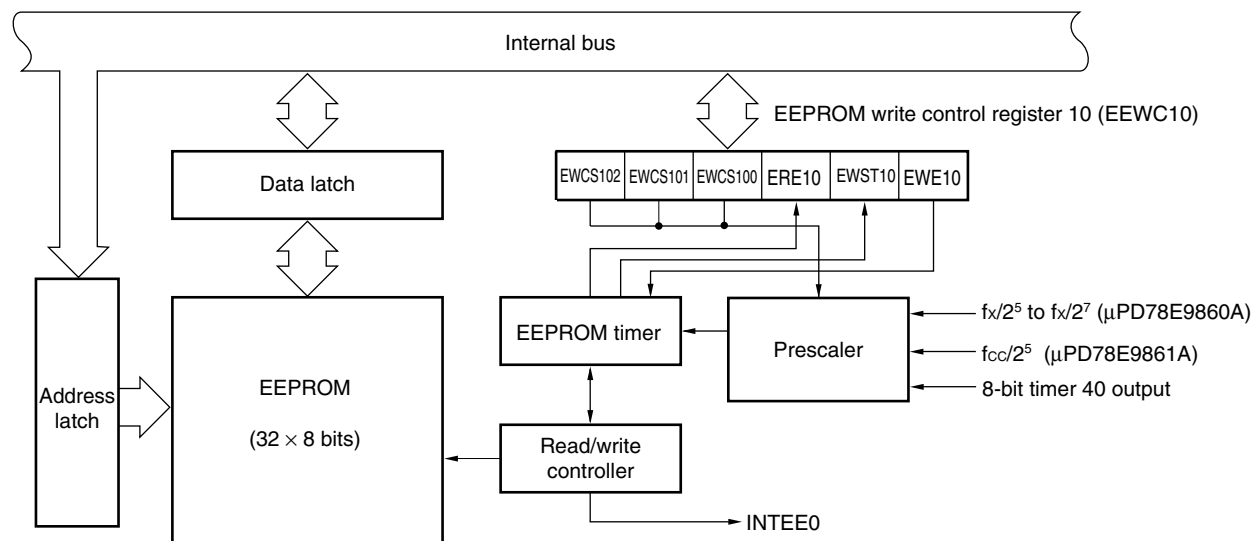

5.3 EEPROM Control Register

EEPROM is controlled by EEPROM write control register 10 (EEWC10).

EEWC10 is the register that sets the EEPROM count clock selection, and EEPROM write control.

EEWC10 is set with a 1-bit or 8-bit memory manipulation instruction.

$\overline{\text{RESET}}$ input sets this register to 08H.

Figure 5-2 shows the format of EEPROM write control register 10. Tables 5-1 and 5-2 show EEPROM write times.

Figure 5-2. Format of EEPROM Write Control Register 10

Symbol	7	6	5	4	3	<2>	<1>	<0>	Address	After reset	R/W
EEWC10	0	EWCS102	EWCS101	EWCS100	1	ERE10	EWST10	EWE10	FFD8H	08H	R/W ^{Note 1}

★

EWCS102	EWCS101	EWCS100	EEPROM timer count clock selection	
0	1	0	$f_x/2^5$ or $f_{cc}/2^5$	(Setting enabled only when f_{cc} or $f_x < 1.41$ MHz)
0	1	1	$f_x/2^6$	(Setting enabled only when $1.41 \leq f_x \leq 2.81$ MHz)
1	0	0	$f_x/2^7$	(Setting enabled only when $f_x > 2.81$ MHz)
1	1	0	Output of 8-bit timer 40 ^{Note 2}	(Setting enabled only when 8-bit timer 40 is operating in discrete mode)
Other than above			Setting prohibited	

ERE10	EWE10	Write	Read	Remarks
0	0	Disabled	Disabled	EEPROM is in standby state (low power consumption mode)
0	1	Setting prohibited		
1	0	Disabled	Enabled	
1	1	Enabled	Enabled	

EWST10	EEPROM write status flag
0	Not writing to EEPROM (EEPROM can be read or written. However, writing is disabled if EWE10 = 0.)
1	Writing to EEPROM (EEPROM cannot be read or written.)

Notes 1. Bit 1 is read only.

★

2. Even if timer 40 output is disabled ($TOE40 = 0$), the timer output signal is internally supplied to EEPROM.

Caution Be sure to set bit 3 to 1 and bit 7 to 0.

Remarks 1. f_x : System clock oscillation frequency (ceramic/crystal oscillation)
 2. f_{cc} : System clock oscillation frequency (RC oscillation)

★ **Table 5-1. EEPROM Write Time (When Operating at $f_x = 5.0$ MHz)**

EWCS102	EWCS101	EWCS100	EEPROM Timer Count Clock	EEPROM Data Write Time ^{Note 1}
1	0	0	$f_x/2^7$ (39.1 kHz)	$2^7/f_x \times 145$ (3.71 ms)
1	1	0	Output of 8-bit timer 40 ^{Note 2}	Output of 8-bit timer 40×145
Other than above			Setting prohibited	

- Notes**
1. Be sure to set the EEPROM write time within the range of 3.3 to 6.6 ms.
 2. Even if timer 40 output is disabled ($TOE40 = 0$), the timer output signal is internally supplied to EEPROM.

Remark f_x : System clock oscillation frequency (ceramic/crystal oscillation)

★ **Table 5-2. EEPROM Write Time (When Operating at $f_{cc} = 1.0$ MHz)**

EWCS102	EWCS101	EWCS100	EEPROM Timer Count Clock	EEPROM Data Write Time ^{Note 1}
0	1	0	$f_{cc}/2^5$ (31.3 kHz)	$2^5/f_{cc} \times 145$ (4.64 ms)
1	1	0	Output of 8-bit timer 40 ^{Note 2}	Output of 8-bit timer 40×145
Other than above			Setting prohibited	

- Notes**
1. Be sure to set the EEPROM write time within the range of 3.3 to 6.6 ms.
 2. Even if timer 40 output is disabled ($TOE40 = 0$), the timer output signal is internally supplied to EEPROM.

Remark f_{cc} : System clock oscillation frequency (RC oscillation)

5.4 Notes for EEPROM Writing

The following caution points pertain to writing to EEPROM.

- (1) When fetching an instruction from EEPROM or stopping the system clock oscillator, be sure to do so after setting EEPROM to write-disabled (EWE10 = 0).
- (2) Set the count clock in a state in which the selected clock is operating (oscillating). If the selected count clock is stopped, there is no transition to the state in which writing is possible even if the clock operation is subsequently started and EEPROM is set to write-enabled (EWE10 = 1).
- (3) Be sure to set the EEPROM write time within the range of 3.3 to 6.6 ms.
- (4) When setting ERE10 and EWE10, be sure to use the following procedure. If you set these using other than the following procedure, there is no transition to the state in which writing to EEPROM is possible.

- <1> Set ERE10 to 1 (In a state in which EWE10 = 0)
- <2> Set EWE10 to 1 (In a state in which ERE10 = 1)
- <3> Wait 1 ms or more using software
- <4> Shift to state in which writing to EEPROM is possible

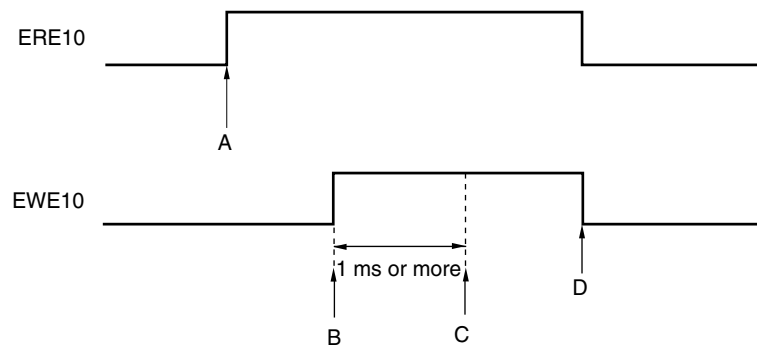

- A (ERE10 = 1): Transition to state in which reading is possible
 B (EWE10 = 1): Set count clock before this point.
 C: Transition to state in which writing is possible
 D: When ERE10 is cleared (ERE10 = 0), EWE10 is also cleared (EWE10 = 0).
 Reading or writing is not possible in this state.

- (5) When performing a write to EEPROM, execute it after confirming that EWST10 = 0.
 If a write is executed to EEPROM when EWST10 = 1, the instruction is ignored.

(6) Do not execute the following operations while writing to EEPROM, as execution will cause the EEPROM cell value at that address to become undefined.

- Turn off the power
- Execute a reset
- Set ERE10 to 0
- Set EWE10 to 0
- Switch the EEPROM timer count clock

(7) Do not execute the following operation while writing to EEPROM after selecting system clock division for the EEPROM timer count clock, as execution will cause the EEPROM cell value at that address to become undefined.

- Execute a STOP instruction

(8) Do not execute the following operations while writing to EEPROM after selecting 8-bit timer 40 (TM40) output for the EEPROM timer count clock, as execution will cause the EEPROM cell value at that address to become undefined.

- Execute a STOP instruction
- Set 8-bit timer 40 operation mode to other than “discrete mode”
- Stop 8-bit timer 40 operation

★

(9) Do not execute the following operations while writing to or reading from EEPROM, as execution will cause the EEPROM data read next to become undefined, and a CPU inadvertent program loop could result.

- Set ERE10 to 0
- Execute a write to EEPROM

(10) When not writing to or reading from EEPROM, it is possible to enter low-power consumption mode by setting ERE10 to 0. In the ERE10 = 1 state, a current of about 0.27 mA ($V_{DD} = 3.6$ V) is always flowing. If an instruction to read from EEPROM is then executed, a further 0.9 mA current will flow, increasing the total current flow at this time to approximately 1.17 mA ($V_{DD} = 3.6$ V).

In the ERE10 = 1, EWE10 = 1 state, a current of about 0.3 mA ($V_{DD} = 3.6$ V) is always flowing. If an instruction to write to EEPROM is then executed, a further 0.7 mA current will flow, and if an instruction to read from EEPROM is executed, a further 0.9 mA current will flow, increasing the total current flow at this time to approximately 1.0 mA ($V_{DD} = 3.6$ V) for the former case and 1.2 mA ($V_{DD} = 3.6$ V) for the latter.

(11) Execution of a STOP instruction causes an automatic change to low-power consumption mode, regardless of the ERE10 and EWE10 settings. The states of ERE10 and EWE10 at the time are maintained. During the wait time following STOP mode release, a current of approximately 300 μ A ($V_{DD} = 3.6$ V) flows.

Executing a HALT instruction does not change the mode to low-power consumption mode.

CHAPTER 6 PORT FUNCTIONS

6.1 Port Functions

The PD789052, 789062 Subseries is provided with the ports shown in Table 6-1. These ports enable several types of control.

These ports, while originally designed as digital input/output ports, have alternate functions. For the alternate functions, refer to **CHAPTER 3 PIN FUNCTIONS**.

Table 6-1. Port Functions

Name	Pin Name	Function
Port 0	P00 to P07	I/O port. Input/output can be specified in 1-bit units.
Port 2	P20, P21	I/O port. Input/output can be specified in 1-bit units.
Port 4	P40 to P43	Input-only port. Mask ROM versions can specify an on-chip pull-up resistor by means of the mask option.

6.2 Port Configuration

Ports include the following hardware.

Table 6-2. Configuration of Port

Item	Configuration
Control registers	Port mode registers (PMm: m = 0, 2)
Ports	Total: 14 (CMOS I/O: 10, CMOS input: 4)
Pull-up resistors	Mask ROM version: 4 (mask option control only) EEPROM version: None

6.2.1 Port 0

This is an 8-bit I/O port with an output latch. Port 0 can be set to input or output mode in 1-bit units by using port mode register 0 (PM0).

$\overline{\text{RESET}}$ input sets port 0 to input mode.

Figure 6-1 shows a block diagram of port 0.

Figure 6-1. Block Diagram of P00 to P07

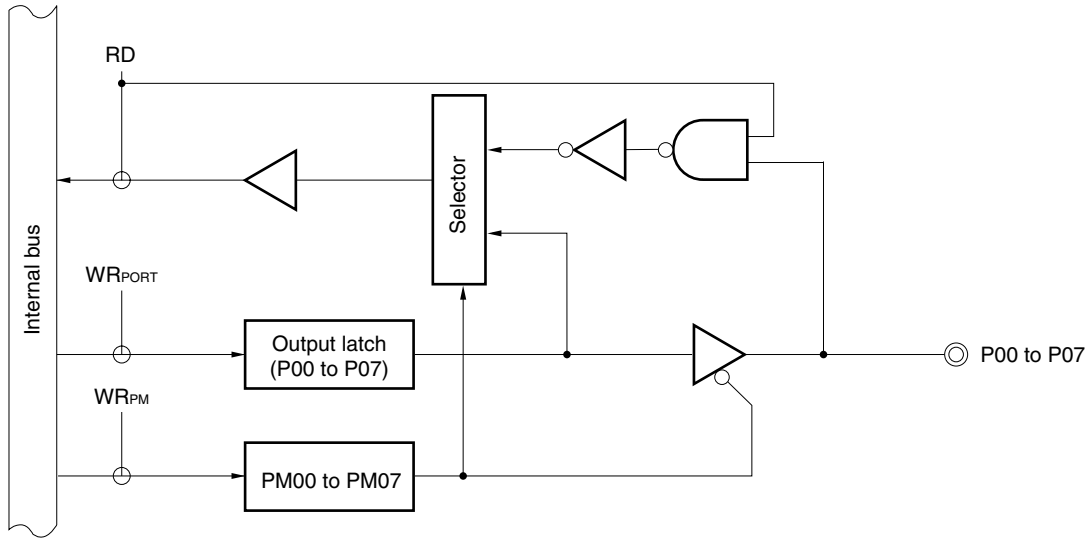

- PM: Port mode register
- RD: Port 0 read signal
- WR: Port 0 write signal

6.2.2 Port 2

This is a 2-bit I/O port with output latches. Port 2 can be set to input or output mode in 1-bit units by using port mode register 2 (PM2).

$\overline{\text{RESET}}$ input sets port 2 to input mode.

Figures 6-2 and 6-3 show block diagrams of port 2.

Figure 6-2. Block Diagram of P20

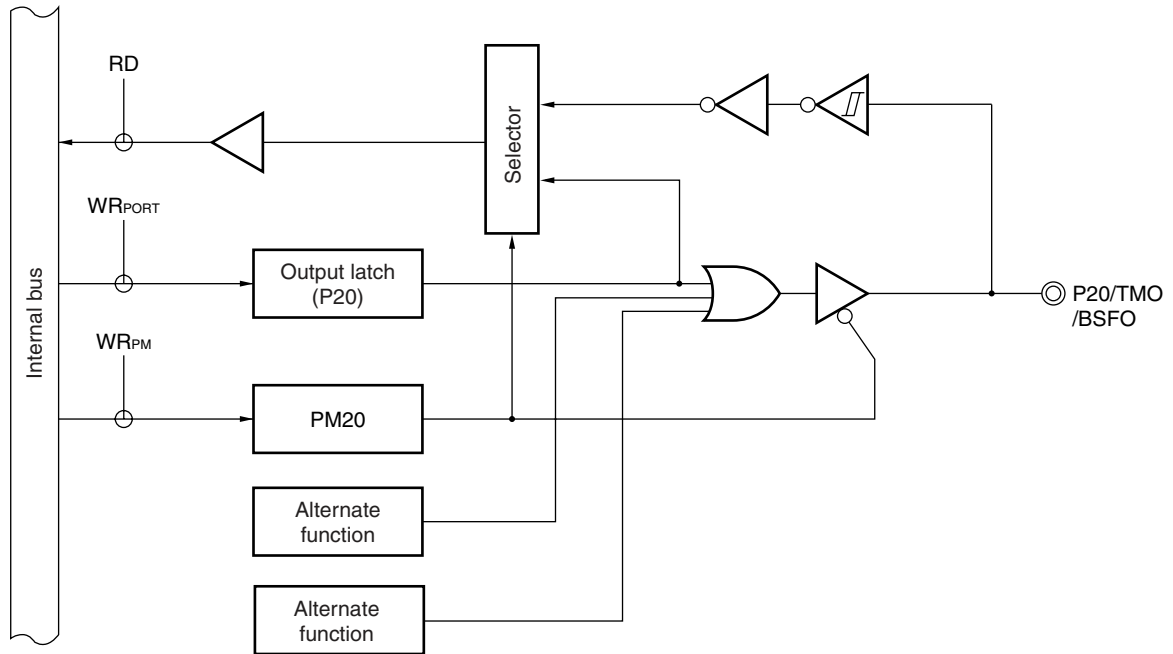

- PM: Port mode register
- RD: Port 2 read signal
- WR: Port 2 write signal

Figure 6-3. Block Diagram of P21

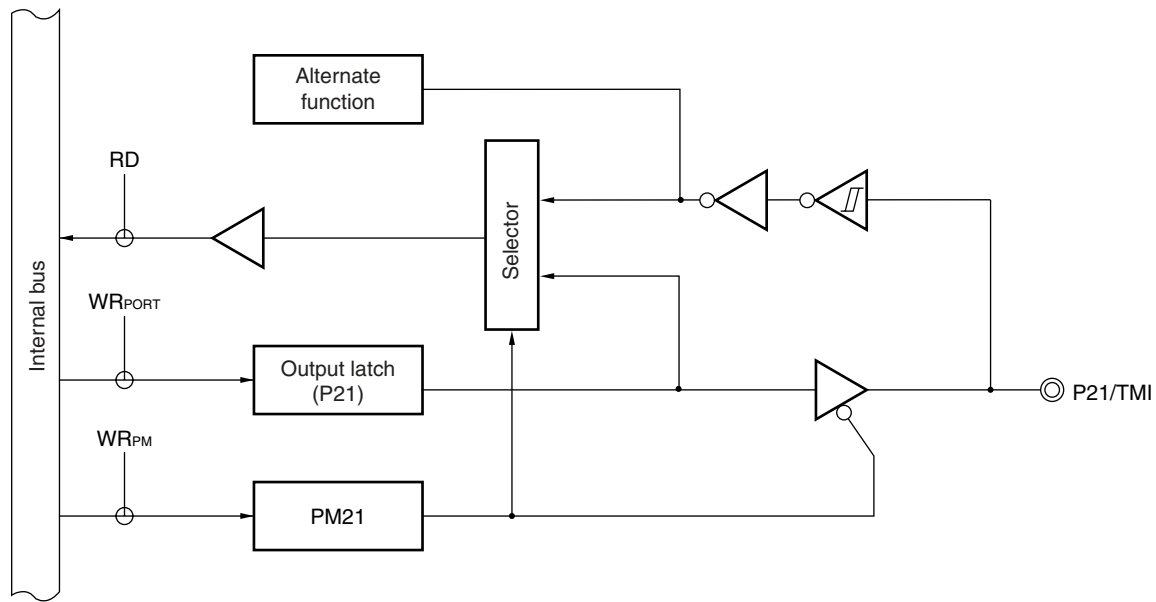

PM: Port mode register
 RD: Port 2 read signal
 WR: Port 2 write signal

6.2.3 Port 4

This is a 4-bit input-only port. Mask ROM versions can specify an on-chip pull-up resistor by means of the mask option.

The port is also used as key return input.

$\overline{\text{RESET}}$ input sets port 4 to input mode.

Figure 6-4 shows a block diagram of port 4.

Figure 6-4. Block Diagram of P40 to P43

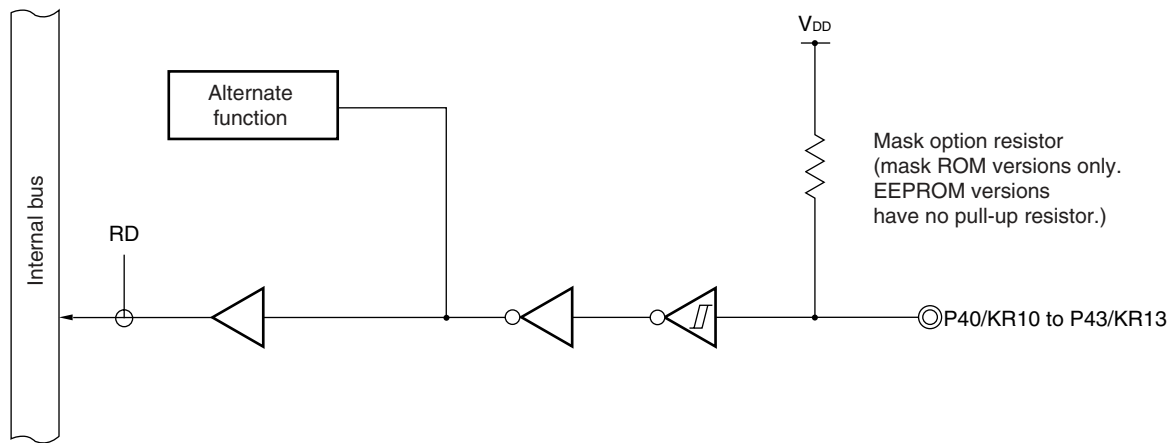

RD: Port 4 read signal

6.3 Port Function Control Registers

The following registers are used to control the ports.

- Port mode registers (PM0, PM2)

(1) Port mode registers (PM0, PM2)

The port mode registers separately set each port bit to either input or output.

Each port mode register is set with a 1-bit or 8-bit memory manipulation instruction.

RESET input sets the port mode registers to FFH.

When port pins are used for alternate functions, the corresponding port mode register and output latch must be set or reset as described in Table 6-3.

Figure 6-5. Format of Port Mode Register

Symbol	7	6	5	4	3	2	1	0	Address	After reset	R/W
PM0	PM07	PM06	PM05	PM04	PM03	PM02	PM01	PM00	FF20H	FFH	R/W
PM2	1	1	1	1	1	1	PM21	PM20	FF22H	FFH	R/W

PMmn	Pmn pin input/output mode selection (m = 0, 2, n = 0 to 7)
0	Output mode (output buffer on)
1	Input mode (output buffer off)

Table 6-3. Port Mode Register and Output Latch Settings for Using Alternate Functions

Pin Name	Alternate Function		PM	P
	Name	Input/Output		
P20	TMO	Output	0	0
	BSFO	Output	0	0
P21	TMI	Input	1	

- Remark** :
- don't care
 - PM : Port mode register
 - P : Port output latch

6.4 Operation of Port Functions

The operation of a port differs depending on whether the port is set to input or output mode, as described below.

6.4.1 Writing to I/O port

(1) In output mode

A value can be written to the output latch of a port by using a transfer instruction. The contents of the output latch can be output from the pins of the port.

The data once written to the output latch is retained until new data is written to the output latch.

(2) In input mode

A value can be written to the output latch by using a transfer instruction. However, the status of the port pin is not changed because the output buffer is OFF.

The data once written to the output latch is retained until new data is written to the output latch.

Caution A 1-bit memory manipulation instruction is executed to manipulate one bit of a port. However, this instruction accesses the port in 8-bit units. When this instruction is executed to manipulate a bit of a port consisting both of inputs and outputs, therefore, the contents of the output latch of the pin that is set to input mode and not subject to manipulation become undefined.

6.4.2 Reading from I/O port

(1) In output mode

The contents of the output latch can be read by using a transfer instruction. The contents of the output latch are not changed.

(2) In input mode

The status of a pin can be read by using a transfer instruction. The contents of the output latch are not changed.

6.4.3 Arithmetic operation of I/O port

(1) In output mode

An arithmetic operation can be performed with the contents of the output latch. The result of the operation is written to the output latch. The contents of the output latch are output from the port pins.

The data once written to the output latch is retained until new data is written to the output latch.

(2) In input mode

The contents of the output latch become undefined. However, the status of the pin is not changed because the output buffer is OFF.

Caution A 1-bit memory manipulation instruction is executed to manipulate one bit of a port. However, this instruction accesses the port in 8-bit units. When this instruction is executed to manipulate a bit of a port consisting both of inputs and outputs, therefore, the contents of the output latch of the pin that is set to input mode and not subject to manipulation become undefined.

CHAPTER 7 CLOCK GENERATOR (μ PD789052 SUBSERIES)

7.1 Clock Generator Functions

The clock generator generates the clock to be supplied to the CPU and peripheral hardware. The following type of system clock oscillator is used.

- System clock (crystal/ceramic) oscillator
This circuit oscillates at 1.0 to 5.0 MHz. Oscillation can be stopped by executing the STOP instruction.

7.2 Clock Generator Configuration

The clock generator includes the following hardware.

Table 7-1. Configuration of Clock Generator

Item	Configuration
Control register	Processor clock control register (PCC)
Oscillator	Crystal/ceramic oscillator

Figure 7-1. Block Diagram of Clock Generator

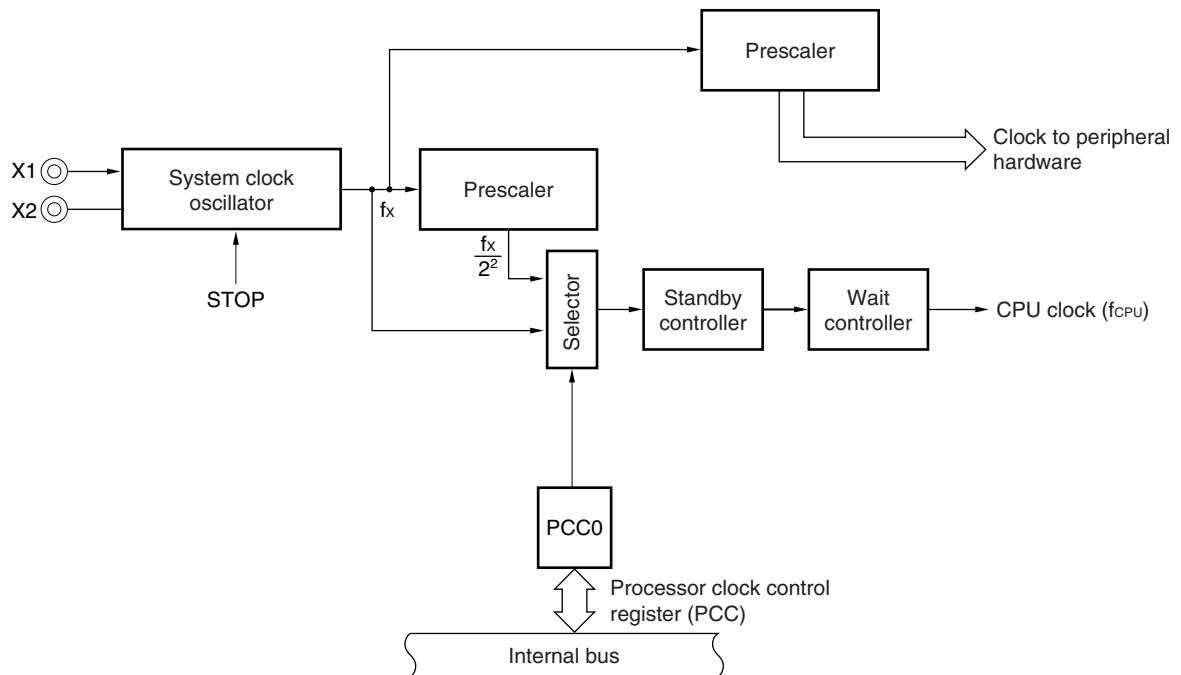

7.3 Clock Generator Control Register

The clock generator is controlled by the following register:

- Processor clock control register (PCC)

(1) Processor clock control register (PCC)

PCC selects the CPU clock and the division ratio.

PCC is set with a 1-bit or 8-bit memory manipulation instruction.

$\overline{\text{RESET}}$ input sets PCC to 02H.

Figure 7-2. Format of Processor Clock Control Register

Symbol	7	6	5	4	3	2	1	0	Address	After reset	R/W
PCC	0	0	0	0	0	0	PCC0	0	FFFBH	02H	R/W

PCC0	CPU clock (f_{CPU}) selection		Minimum instruction execution time: $2/f_{\text{CPU}}$
			At $f_x = 5.0$ MHz operation
0	f_x		$0.4 \mu\text{s}$
1	$f_x/2^2$		$1.6 \mu\text{s}$

Caution Bits 0 and 2 to 7 must all be set to 0.

Remark f_x : System clock oscillation frequency

7.4 System Clock Oscillators

7.4.1 System clock oscillator

The system clock oscillator is oscillated by the crystal or ceramic resonator (5.0 MHz TYP.) connected across the X1 and X2 pins.

An external clock can also be input to the circuit. In this case, input the clock signal to the X1 pin, and input the inverted signal to the X2 pin.

Figure 7-3 shows the external circuit of the system clock oscillator.

Figure 7-3. External Circuit of System Clock Oscillator

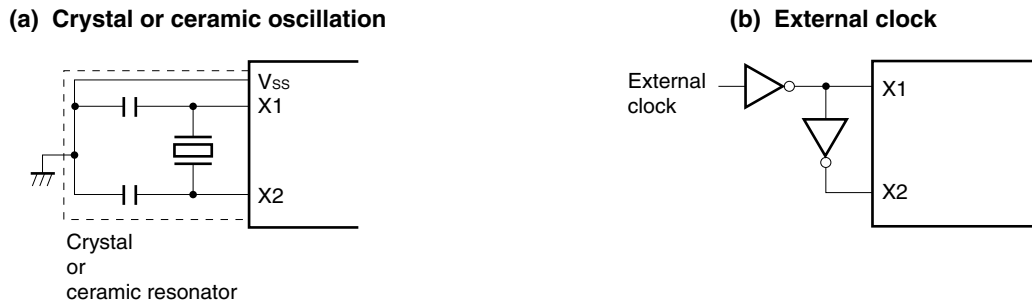

Caution When using the system clock oscillator, wire as follows in the area enclosed by the broken lines in Figure 7-3 to avoid an adverse effect from wiring capacitance.

- Keep the wiring length as short as possible.
- Do not cross the wiring with the other signal lines. Do not route the wiring near a signal line through which a high fluctuating current flows.
- Always make the ground point of the oscillator capacitor the same potential as V_{SS} . Do not ground the capacitor to a ground pattern through which a high current flows.
- Do not fetch signals from the oscillator.

7.4.2 Examples of incorrect resonator connection

Figure 7-4 shows an example of incorrect resonator connections.

Figure 7-4. Example of Incorrect Resonator Connection (1/2)

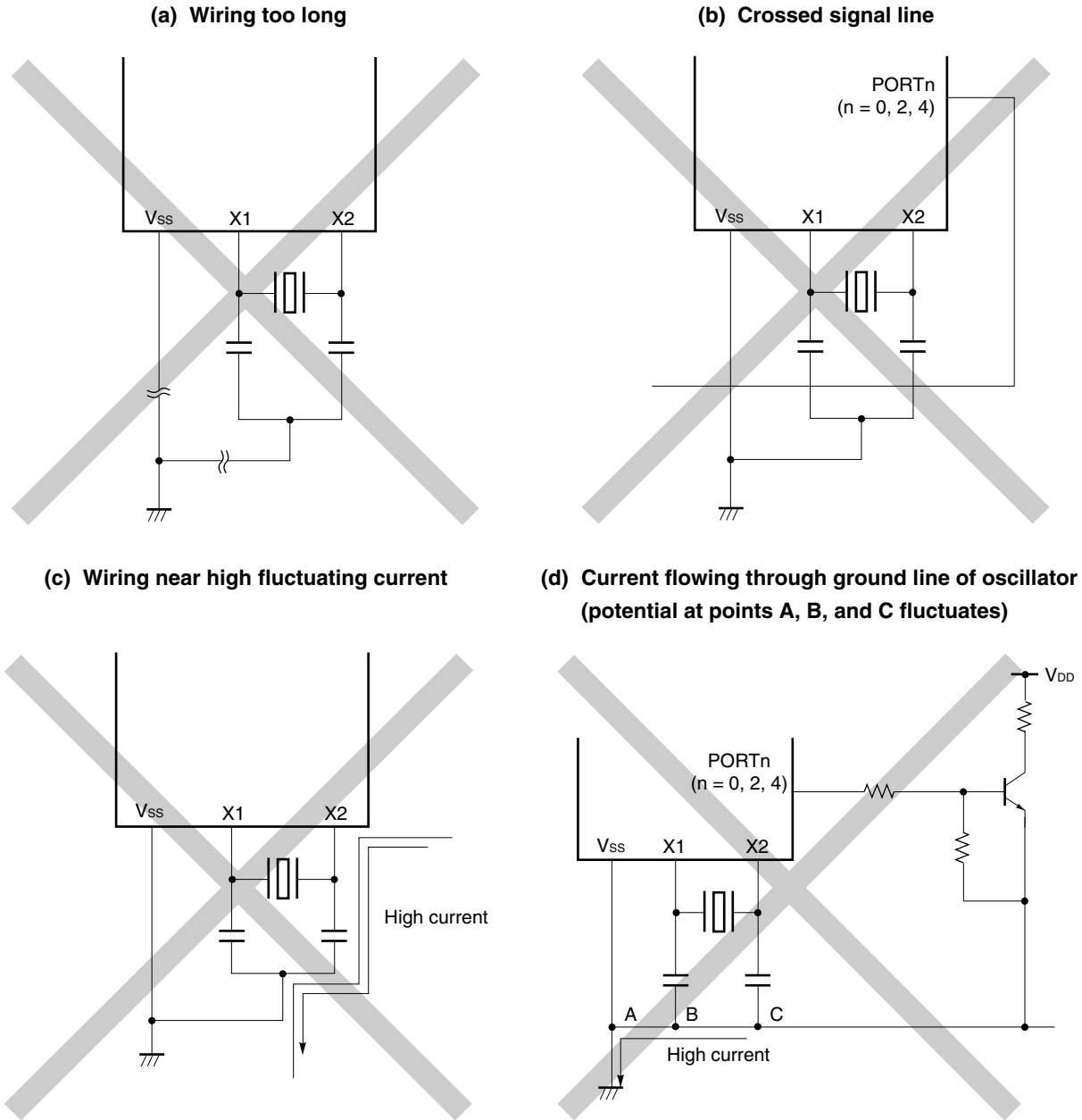
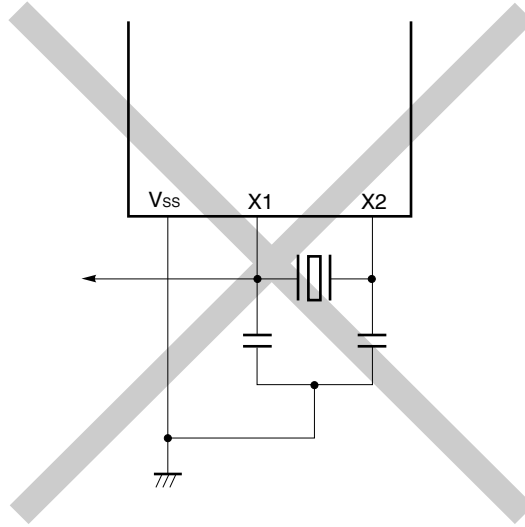

Figure 7-4. Example of Incorrect Resonator Connection (2/2)

(e) Signal is fetched



7.4.3 Frequency divider

The frequency divider divides the system clock oscillator output (fx) and generates clocks.

7.5 Clock Generator Operation

The clock generator generates the following clocks and controls the operation modes of the CPU, such as standby mode:

- System clock f_x
- CPU clock f_{CPU}
- Clock to peripheral hardware

The operation of the clock generator is determined by the processor clock control register (PCC) as follows:

- (a) The slow mode (1.6 μ s: at 5.0 MHz operation) of the system clock is selected when the $\overline{\text{RESET}}$ signal is generated (PCC = 02H). While a low level is input to the $\overline{\text{RESET}}$ pin, oscillation of the system clock is stopped.
- (b) Two types of minimum instruction execution time (f_{CPU}) (0.4 μ s, 1.6 μ s: at 5.0 MHz operation) can be selected by the PCC setting.
- (c) Two standby modes, STOP and HALT, can be used.
- (d) The clock for the peripheral hardware is generated by dividing the frequency of the system clock. Therefore, the peripheral hardware stops when the system clock stops (except for an external input clock).

7.6 Changing Setting of CPU Clock

7.6.1 Time required for switching CPU clock

The CPU clock can be selected by using bit 1 (PCC0) of the processor clock control register (PCC).

Actually, the specified clock is not selected immediately after the setting of PCC has been changed, and the old clock is used for the duration of several instructions after that (see **Table 7-2**).

Table 7-2. Maximum Time Required for Switching CPU Clock

Set Value Before Switching	Set Value After Switching	
	PCC0	PCC0
0	0	1
	1	4 clocks
1	2 clocks	

Remark Two clocks are the minimum instruction execution time of the CPU clock before switching.

7.6.2 Switching CPU clock

The following figure illustrates how the CPU clock is switched.

Figure 7-5. Switching Between System Clock and CPU Clock

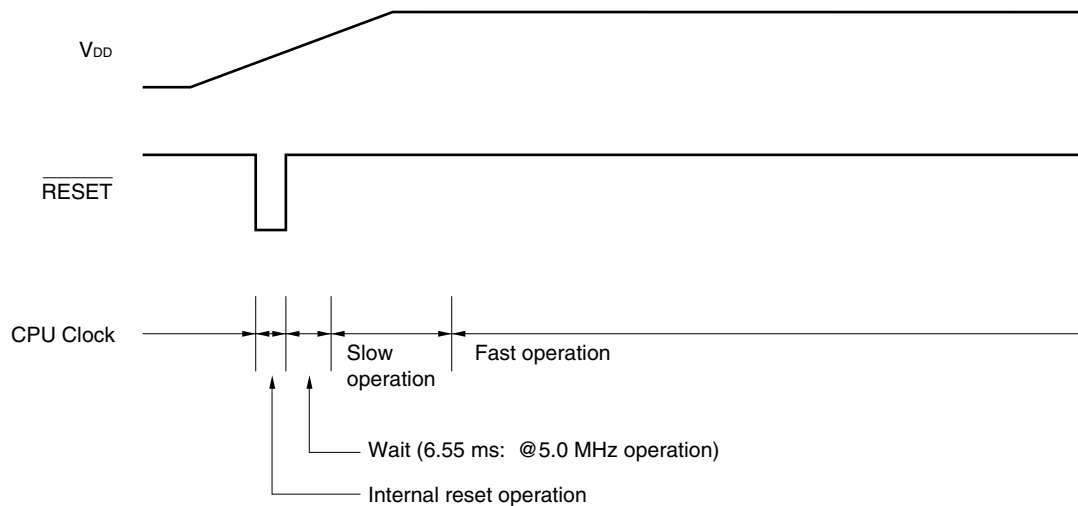

<1> The CPU is reset when the $\overline{\text{RESET}}$ pin is made low on power application. The effect of resetting is released when the $\overline{\text{RESET}}$ pin is later made high, and the system clock starts oscillating. At this time, the oscillation stabilization time ($2^{15}/f_x$) is automatically secured.

After that, the CPU starts instruction execution at the slow speed of the system clock (1.6 μ s: @ 5.0 MHz operation).

<2> After the time required for the V_{DD} voltage to rise to the level at which the CPU can operate at the high speed has elapsed, the processor clock control register (PCC) is rewritten so that the high-speed operation can be selected.

CHAPTER 8 CLOCK GENERATOR (μ PD789062 SUBSERIES)

8.1 Clock Generator Functions

The clock generator generates the clock to be supplied to the CPU and peripheral hardware. The following type of system clock oscillator is used.

- System clock (RC) oscillator
This circuit oscillates at 1.0 MHz \pm 15%. Oscillation can be stopped by executing the STOP instruction.

8.2 Clock Generator Configuration

The clock generator includes the following hardware.

Table 8-1. Configuration of Clock Generator

Item	Configuration
Control register	Processor clock control register (PCC)
Oscillator	RC oscillator

Figure 8-1. Block Diagram of Clock Generator

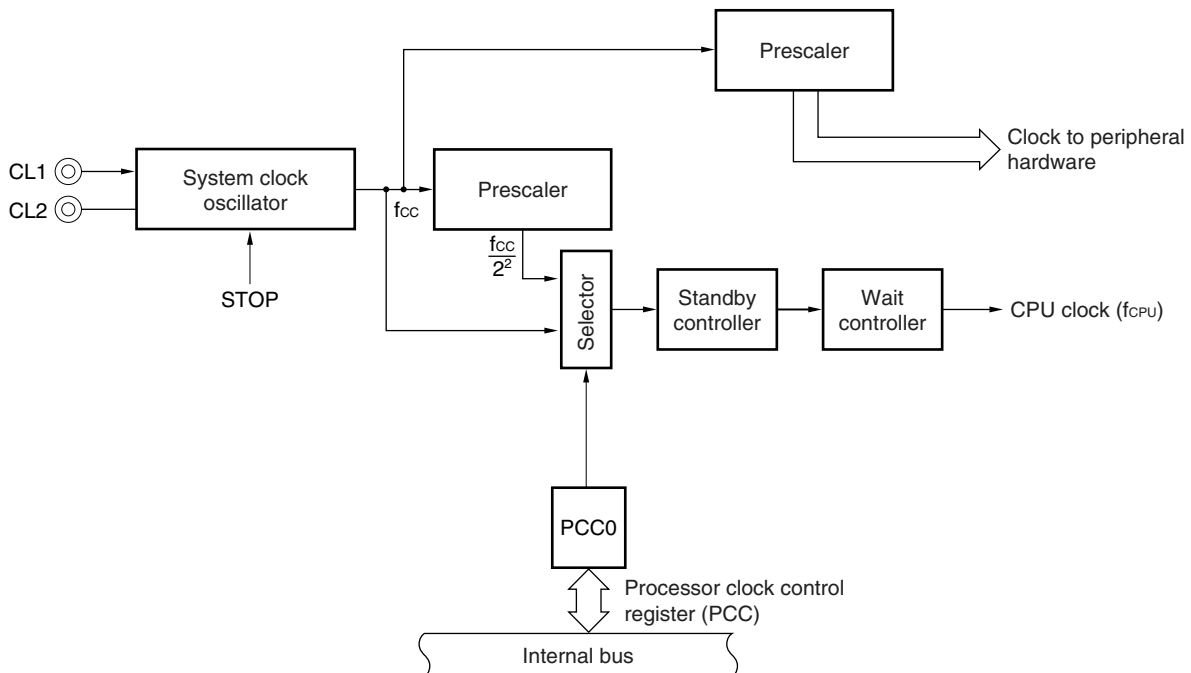

8.3 Clock Generator Control Register

The clock generator is controlled by the following register:

- Processor clock control register (PCC)

(1) Processor clock control register (PCC)

PCC selects the CPU clock and the division ratio.

PCC is set with a 1-bit or 8-bit memory manipulation instruction.

$\overline{\text{RESET}}$ input sets PCC to 02H.

Figure 8-2. Format of Processor Clock Control Register

Symbol	7	6	5	4	3	2	1	0	Address	After reset	R/W
PCC	0	0	0	0	0	0	PCC0	0	FFFBH	02H	R/W

PCC0	CPU clock (f_{CPU}) selection		Minimum instruction execution time: $2/f_{\text{CPU}}$
			At $f_{\text{CC}} = 1.0 \text{ MHz}$ operation
0	f_{CC}		$2.0 \mu\text{s}$
1	$f_{\text{CC}}/2^2$		$8.0 \mu\text{s}$

Caution Bits 0 and 2 to 7 must all be set to 0.

Remark f_{CC} : System clock oscillation frequency

8.4 System Clock Oscillators

8.4.1 System clock oscillator

The system clock oscillator is oscillated by the resistor (R) and capacitor (C) (1.0 MHz TYP.) connected across the CL1 and CL2 pins.

An external clock can also be input to the circuit. In this case, input the clock signal to the CL1 pin, and input the inverted signal to the CL2 pin.

Figure 8-3 shows the external circuit of the system clock oscillator.

Figure 8-3. External Circuit of System Clock Oscillator

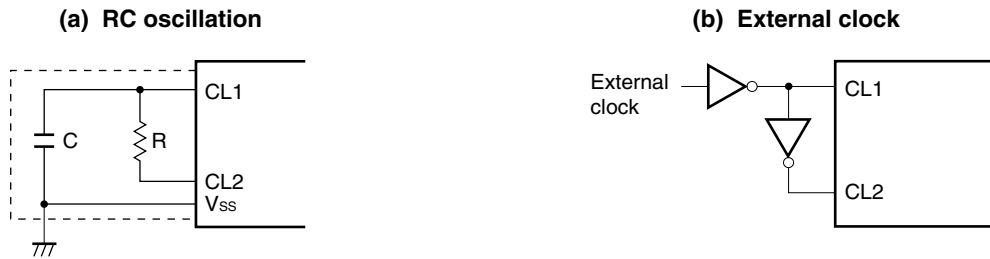

Caution When using the system clock oscillator, wire as follows in the area enclosed by the broken lines in Figure 8-3 to avoid an adverse effect from wiring capacitance.

- Keep the wiring length as short as possible.
- Do not cross the wiring with the other signal lines. Do not route the wiring near a signal line through which a high fluctuating current flows.
- Always make the ground point of the oscillator capacitor the same potential as V_{SS}. Do not ground the capacitor to a ground pattern through which a high current flows.
- Do not fetch signals from the oscillator.

8.4.2 Examples of incorrect resonator connection

Figure 8-4 shows an example of incorrect resonator connections.

Figure 8-4. Example of Incorrect Resonator Connection (1/2)

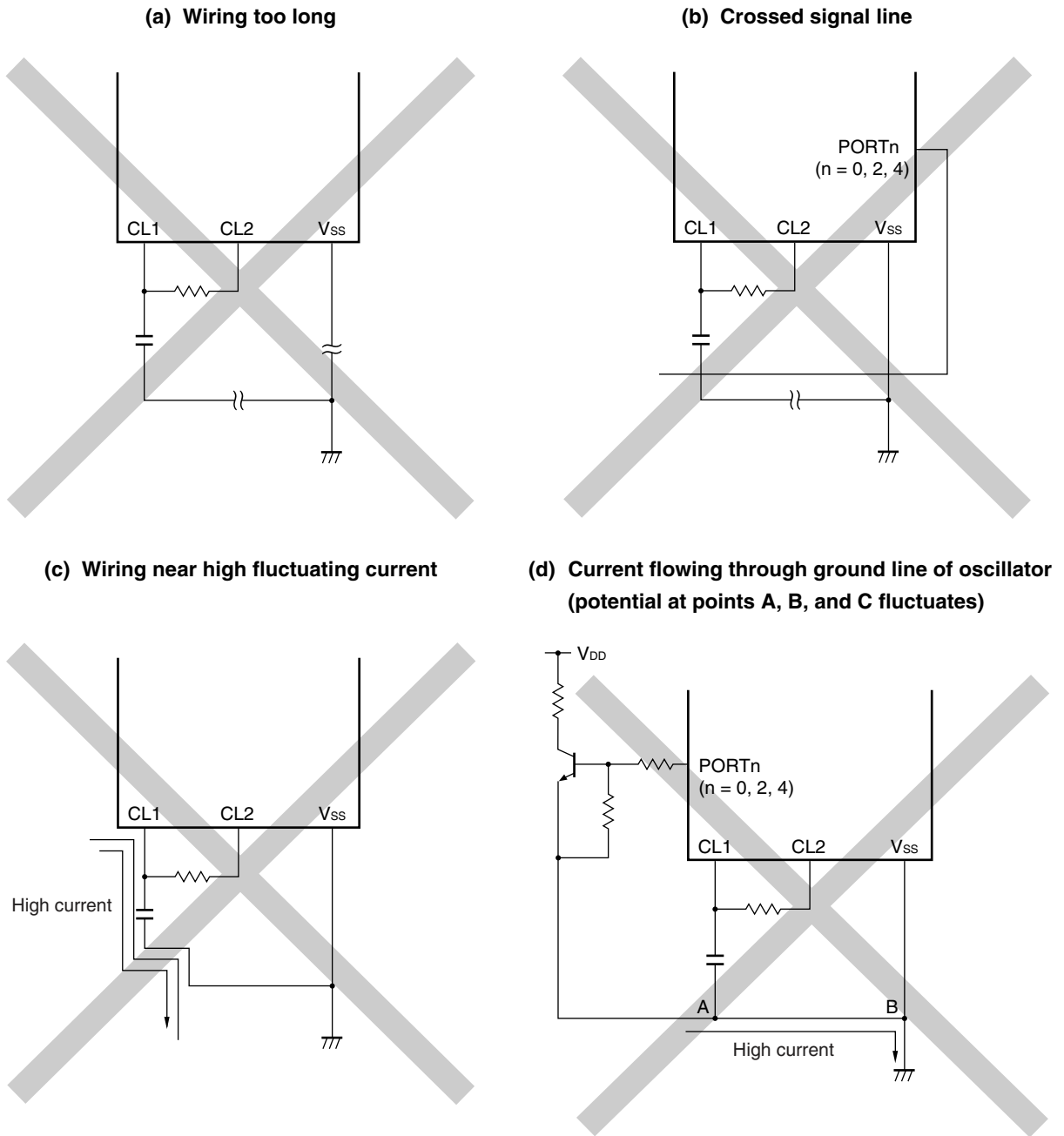
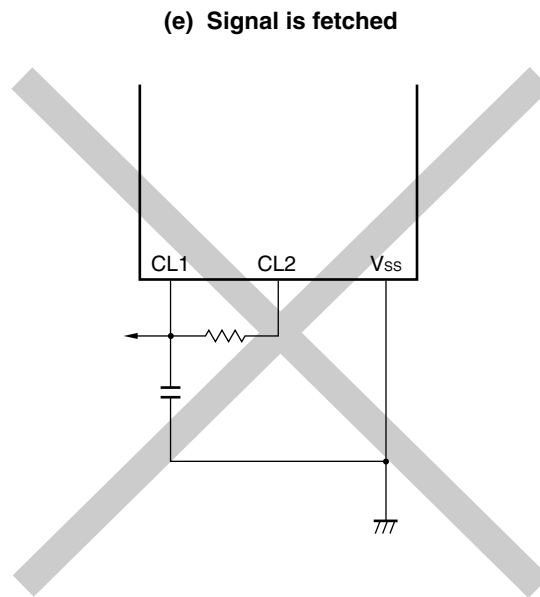

Figure 8-4. Example of Incorrect Resonator Connection (2/2)



8.4.3 Frequency divider

The frequency divider divides the system clock oscillator output (fcc) and generates clocks.

8.5 Clock Generator Operation

The clock generator generates the following clocks and controls the operation modes of the CPU, such as standby mode:

- System clock f_{CC}
- CPU clock f_{CPU}
- Clock to peripheral hardware

The operation of the clock generator is determined by the processor clock control register (PCC) as follows:

- (a) The slow mode (8.0 μ s: at 1.0 MHz operation) of the system clock is selected when the $\overline{\text{RESET}}$ signal is generated (PCC = 02H). While a low level is input to the $\overline{\text{RESET}}$ pin, oscillation of the system clock is stopped.
- (b) Two types of minimum instruction execution time (f_{CPU}) (2.0 μ s, 8.0 μ s: at 1.0 MHz operation) can be selected by the PCC setting.
- (c) Two standby modes, STOP and HALT, can be used.
- (d) The clock for the peripheral hardware is generated by dividing the frequency of the system clock. Therefore, the peripheral hardware stops when the system clock stops (except for an external input clock).

8.6 Changing Setting of CPU Clock

8.6.1 Time required for switching CPU clock

The CPU clock can be selected by using bit 1 (PCC0) of the processor clock control register (PCC).

Actually, the specified clock is not selected immediately after the setting of PCC has been changed, and the old clock is used for the duration of several instructions after that (see **Table 8-2**).

Table 8-2. Maximum Time Required for Switching CPU Clock

Set Value Before Switching	Set Value After Switching	
PCC0	PCC0	PCC0
	0	1
0		4 clocks
1	2 clocks	

Remark Two clocks are the minimum instruction execution time of the CPU clock before switching.

8.6.2 Switching CPU clock

The following figure illustrates how the CPU clock is switched.

Figure 8-5. Switching Between System Clock and CPU Clock

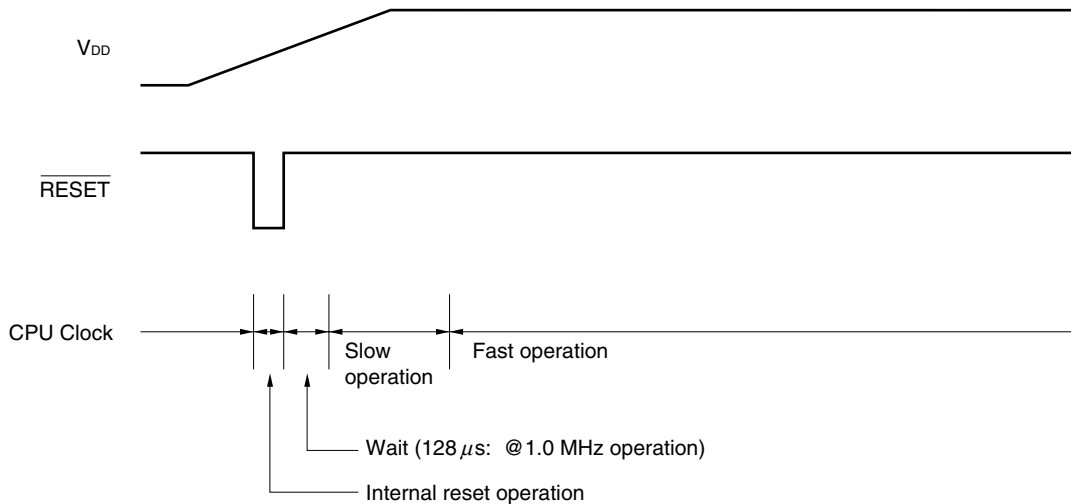

<1> The CPU is reset when the $\overline{\text{RESET}}$ pin is made low on power application. The effect of resetting is released when the $\overline{\text{RESET}}$ pin is later made high, and the system clock starts oscillating. At this time, the oscillation stabilization time ($2^7/f_{cc}$) is automatically secured.

After that, the CPU starts instruction execution at the slow speed of the system clock (8.0 μs: @ 1.0 MHz operation).

<2> After the time required for the V_{DD} voltage to rise to the level at which the CPU can operate at the high speed has elapsed, the processor clock control register (PCC) is rewritten so that the high-speed operation can be selected.

CHAPTER 9 8-BIT TIMERS 30 AND 40

9.1 8-Bit Timers 30 and 40 Functions

The μ PD789052, 789062 Subseries have on chip an 8-bit timer (timer 30) (1 channel) and an 8-bit timer/event counter (timer 40) (1 channel). The operation modes shown in the table below are possible by means of mode register settings.

Table 9-1. Mode List

Mode \ Channel	Timer 30	Timer 40
8-bit timer counter mode (discrete mode)	√	√
16-bit timer counter mode (cascade connection mode)		√
Carrier generator mode		√
PWM output mode	×	√

(1) 8-bit timer counter mode (discrete mode)

The following functions can be used.

- 8-bit resolution interval timer
- 8-bit resolution external event counter (timer 40 only)
- 8-bit resolution square wave output (timer 40 only)

(2) 16-bit timer counter mode (cascade connection mode)

Operates as a 16-bit timer/event counter due to cascade connection.

The following functions can be used.

- 16-bit resolution interval timer
- 16-bit resolution external event counter
- 16-bit resolution square wave output

(3) Carrier generator mode

In this mode, the carrier clock generated by timer 40 is output in the cycle set by timer 30.

(4) PWM output mode (timer 40 only)

Outputs a pulse of an arbitrary duty factor set by timer 40.

9.2 8-Bit Timers 30 and 40 Configuration

The 8-bit timer includes the following hardware.

Table 9-2. Configuration of 8-Bit Timers 30 and 40

Item	Configuration
Timer counter	8 bits × 2 (TM30, TM40)
Registers	Compare registers: 8 bits × 3 (CR30, CR40, CRH40)
Timer output	1 (TMO)
Control registers	8-bit timer mode control register 30 (TMC30) 8-bit timer mode control register 40 (TMC40) Carrier generator output control register 40 (TCA40) Port mode register 2 (PM2) Port 2 (P2)

Figure 9-1. Timer 30 Block Diagram

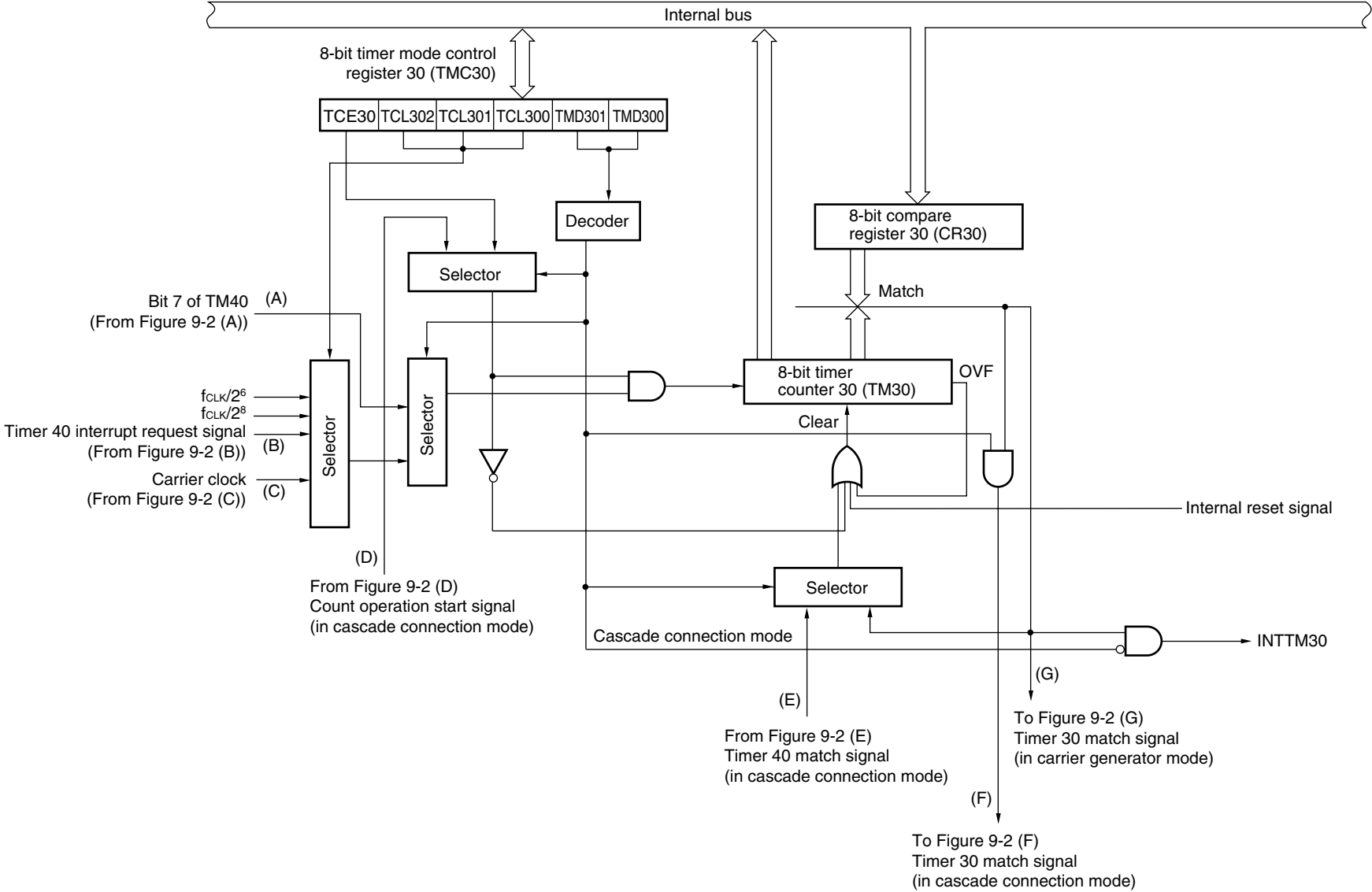

Remark f_{CLK}: fx or fcc



Figure 9-2. Timer 40 Block Diagram

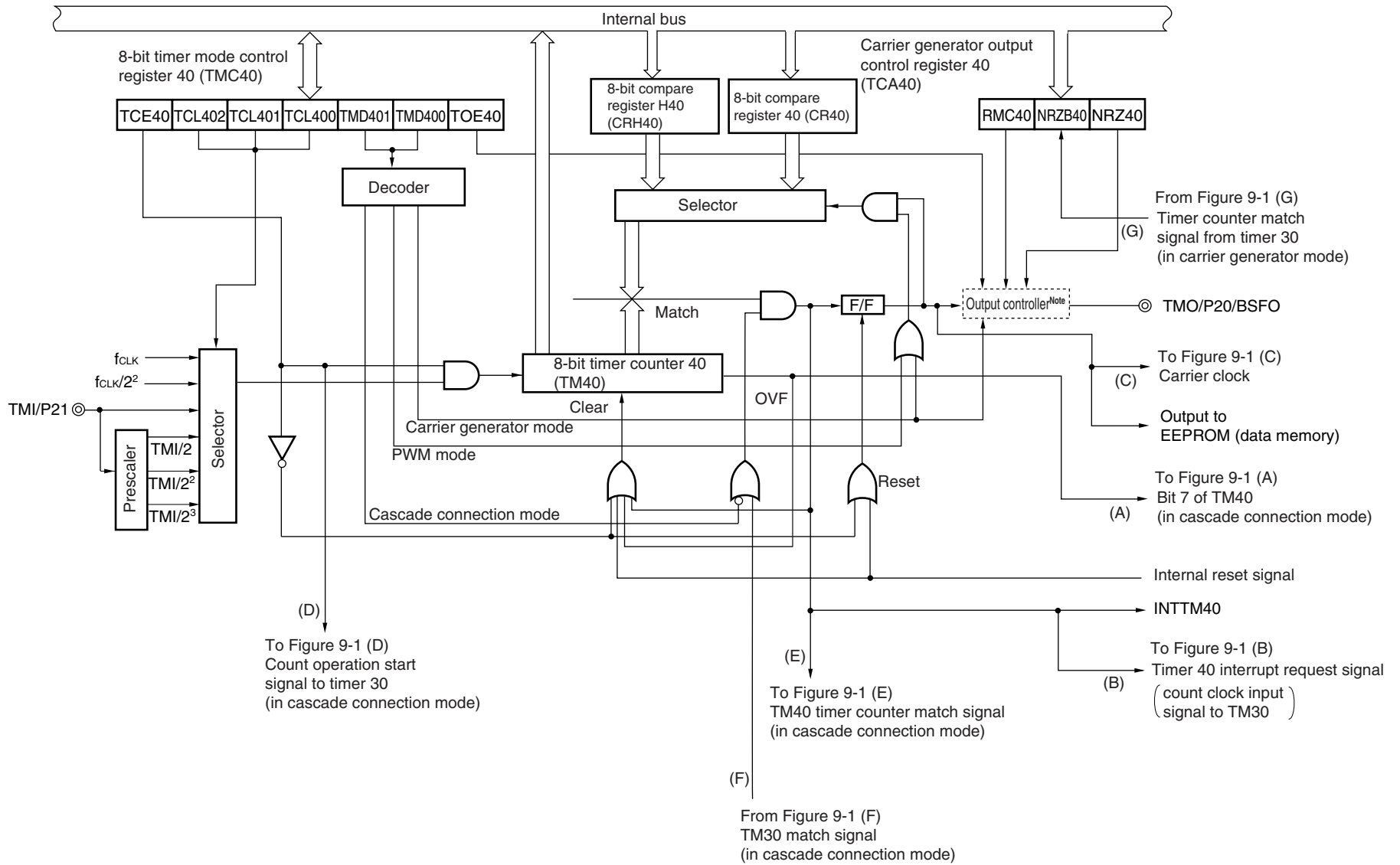

Note For details, refer to Figure 9-3.

Remark fCLK: fx or fcc

Figure 9-3. Block Diagram of Output Controller (Timer 40)

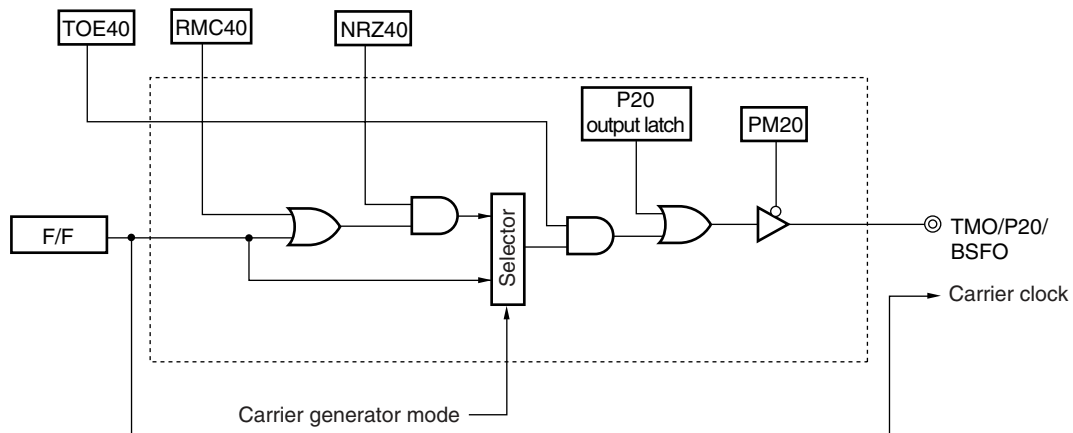
**(1) 8-bit compare register 30 (CR30)**

This register is an 8-bit register that always compares the count value of 8-bit timer counter 30 (TM30) with the value set in CR30 and generates an interrupt request (INTTM30) if they match.

CR30 is set with an 8-bit memory manipulation instruction.

$\overline{\text{RESET}}$ input makes this register undefined.

Caution CR30 cannot be used in PWM output mode.

(2) 8-bit compare register 40 (CR40)

This register is an 8-bit register that always compares the count value of 8-bit timer counter 40 (TM40) with the value set in CR40 and generates an interrupt request (INTTM40) if they match. In addition, when cascade-connected to TM30 and used as a 16-bit timer/event counter, an interrupt request (INTTM40) is generated only if TM30 matches with CR30 and TM40 matches with CR40 simultaneously (INTTM30 is not generated).

In carrier generator mode or PWM output mode, set the low-level width of the timer output.

CR40 is set with an 8-bit memory manipulation instruction.

$\overline{\text{RESET}}$ input makes this register undefined.

(3) 8-bit compare register H40 (CRH40)

In carrier generator mode or PWM output mode, writing a CRH40 value sets the width of high level timer output.

The value set in CRH40 is constantly compared with the TM40 count value, and an interrupt request (INTTM40) is generated if they match.

CRH40 is set with an 8-bit memory manipulation instruction.

$\overline{\text{RESET}}$ input makes this register undefined.

(4) 8-bit timer counters 30 and 40 (TM30, TM40)

These 8-bit registers count pulse counts.

Each of TM30 and TM40 is read with an 8-bit memory manipulation instruction.

$\overline{\text{RESET}}$ input sets these registers to 00H.

The conditions under which TM30 and TM40 are cleared to 00H are shown next.

(a) Discrete mode**(i) TM30**

- Reset
- Clearing of TCE30 (bit 7 of 8-bit timer mode control register 30 (TMC30)) to 0
- Match of TM30 and CR30
- TM30 count value overflow

(ii) TM40

- Reset
- Clearing of TCE40 (bit 7 of 8-bit timer mode control register 40 (TMC40)) to 0
- Match of TM40 and CR40
- TM40 count value overflow

(b) Cascade connection mode (TM30, TM40 simultaneously cleared to 00H)

- Reset
- Clearing of the TCE40 flag to 0
- Simultaneous match of TM30 with CR30 and TM40 with CR40
- TM30 and TM40 count values overflow simultaneously

(c) Carrier generator/PWM output mode (TM40 only)

- Reset
- Clearing of the TCE40 flag to 0
- Match of TM40 and CR40
- Match of TM40 and CRH40
- TM40 count value overflow

9.3 8-Bit Timers 30 and 40 Control Registers

The 8-bit timer is controlled by the following five registers.

- 8-bit timer mode control register 30 (TMC30)
- 8-bit timer mode control register 40 (TMC40)
- Carrier generator output control register 40 (TCA40)
- Port mode register 2 (PM2)
- Port 2 (P2)

(1) 8-bit timer mode control register 30 (TMC30)

8-bit timer mode control register 30 (TMC30) is the register that controls the setting of the timer 30 count clock and the setting of the operating mode.

TMC30 is set with a 1-bit or 8-bit memory manipulation instruction.

$\overline{\text{RESET}}$ input sets this register to 00H.

Figure 9-4. Format of 8-Bit Timer Mode Control Register 30

Symbol	<7>	6	5	4	3	2	1	0	Address	After reset	R/W
TMC30	TCE30	0	TCL302	TCL301	TCL300	TMD301	TMD300	0	FF52H	00H	R/W

TCE30	TM30 count operation control ^{Note 1}
0	Clears TM30 count value and halt operation
1	Starts count operation

TCL302	TCL301	TCL300	Selection of timer 30 count clock	
			When operating at $f_x = 5.0 \text{ MHz}$	When operating at $f_{cc} = 1.0 \text{ MHz}$
0	0	0	$f_x/2^6$ (78.1 kHz)	$f_{cc}/2^6$ (15.6 kHz)
0	0	1	$f_x/2^8$ (19.5 kHz)	$f_{cc}/2^8$ (3.91 kHz)
0	1	0	Timer 40 match signal	
0	1	1	Carrier clock generated by timer 40	
Other than above			Setting prohibited	

TMD301	TMD300	TMD401	TMD400	Selection of timer 30, timer 40 operating mode ^{Note 2}
0	0	0	0	Discrete mode
0	1	0	1	Cascade connection mode
0	0	1	1	Carrier generator mode
0	0	1	0	PWM output mode
Other than above				Setting prohibited

Notes 1. In cascade connection mode, since count operations are controlled by TCE40 (bit 7 of TMC40), TCE30 is ignored even if it is set.

2. The selection of operating mode is made by combining the two registers TMC30 and TMC40.

Cautions 1. Be sure to set bits 0 and 6 to 0.

2. In cascade connection mode, timer 40 output signal is forcibly selected for count clock.

Remarks 1. f_x : System clock oscillation frequency (ceramic/crystal oscillation)

2. f_{cc} : System clock oscillation frequency (RC oscillation)

(2) **8-bit timer mode control register 40 (TMC40)**

8-bit timer mode control register 40 (TMC40) is the register that controls the setting of the timer 40 count clock and the setting of the operating mode.

TMC40 is set with a 1-bit or 8-bit memory manipulation instruction.

$\overline{\text{RESET}}$ input sets this register to 00H.

Figure 9-5. Format of 8-Bit Timer Mode Control Register 40

Symbol	<7>	6	5	4	3	2	1	<0>	Address	After reset	R/W
TMC40	TCE40	0	TCL402	TCL401	TCL400	TMD401	TMD400	TOE40	FF56H	00H	R/W

TCE40	TM40 count operation control ^{Note 1}
0	Clears TM40 count value and halt operation (in cascade connection mode, the TM30 count value is simultaneously cleared as well.)
1	Starts count operation (in cascade connection mode, the TM30 count operation is simultaneously started as well.)

TCL402	TCL401	TCL400	Selection of timer 40 count clock	
			When operating at $f_x = 5.0 \text{ MHz}$	When operating at $f_{cc} = 1.0 \text{ MHz}$
0	0	0	f_x (5.0 MHz)	f_{cc} (1.0 MHz)
0	0	1	$f_x/2^2$ (1.25 MHz)	$f_{cc}/2^2$ (250 kHz)
0	1	0	f_{TMI}	
0	1	1	$f_{TMI}/2$	
1	0	0	$f_{TMI}/2^2$	
1	0	1	$f_{TMI}/2^3$	

TMD301	TMD300	TMD401	TMD400	Selection of timer 30, timer 40 operating mode ^{Note 2}
0	0	0	0	Discrete mode
0	1	0	1	Cascade connection mode
0	0	1	1	Carrier generator mode
0	0	1	0	PWM output mode
Other than above				Setting prohibited

TOE40	Timer output control
0	Output disabled
1	Output enabled (port mode)

Notes 1. In cascade connection mode, since count operations are controlled by TCE40, TCE30 (bit 7 of TMC30) is ignored even if it is set.

2. The selection of operating mode is made by combining the two registers TMC30 and TMC40.

Caution Be sure to clear bit 6 to 0.

- Remarks**
1. f_x : System clock oscillation frequency (ceramic/crystal oscillation)
 2. f_{cc} : System clock oscillation frequency (RC oscillation)
 3. f_{TMI} : External clock input from TMI/P21 pin

(3) Carrier generator output control register 40 (TCA40)

This register is used to set the timer output data in the carrier generator mode.

TCA40 is set with an 8-bit memory manipulation instruction.

$\overline{\text{RESET}}$ input sets this register to 00H.

Figure 9-6. Format of Carrier Generator Output Control Register 40

Symbol	7	6	5	4	3	2	1	0	Address	After reset	R/W
TCA40	0	0	0	0	0	RMC40	NRZB40	NRZ40	FF57H	00H	W

RMC40	Remote controller output control
0	When NRZ40 = 1, a carrier pulse is output to the TMO/P20/BSFO pin
1	When NRZ40 = 1, a high level is output to the TMO/P20/BSFO pin

NRZB40	This bit stores the data that NRZ40 will output next. Data is transferred to NRZ40 at the rising edge of the timer 30 match signal. Input the necessary value in NRZB40 in advance by program.
--------	--

NRZ40	No return, zero data
0	A low level is output (the carrier clock is stopped)
1	A carrier pulse or high level is output

- Cautions**
1. Be sure to clear bits 3 to 7 to 0.
 2. TCA40 cannot be set with a 1-bit memory manipulation instruction. Be sure to use an 8-bit memory manipulation instruction to set TCA40.
 3. The NRZ40 flag can be written only when carrier generator output is stopped (TOE40 = 0). The data cannot be overwritten when TOE40 = 1.
 4. When the carrier generator is stopped once and then started again, NRZB40 does not hold the previous data. Re-set data to NRZB40. At this time, a 1-bit memory manipulation instruction must not be used. Be sure to use an 8-bit memory manipulation instruction.
 5. To enable operation in the carrier generator mode, set a value to the compare registers (CR30, CR40, and CRH40), and input the necessary value to the NRZB40 and NRZ40 flags in advance. Otherwise, the signal of the timer match circuit will become unstable and the NRZ40 flag will be undefined.
 6. Note that the $\mu\text{PD78E9860}$ and 78E9861 have the following restrictions (which do not apply to the mask ROM version and the $\mu\text{PD78E9860A}$ and 78E9861A).
 - (a) While INTTM30 (interrupt generated by the match signal of timer 30) is being output, accessing TCA40 is prohibited.
 - (b) Accessing TCA40 is prohibited while 8-bit timer/counter 30 (TM30) is 00H. To access TCA40 while TM30 = 00H, wait for more than half a period of the TM30 count clock and then rewrite TCA40.

(4) Port mode register 2 (PM2)

This register sets port 2 to input/output in 1-bit units.

When using the P20/TMO/BSFO pin as a timer output, set the PM20 and P20 output latch to 0.

When using the P21/TMI pin as a timer input, set the PM21 to 1.

PM2 is set with a 1-bit or 8-bit memory manipulation instruction.

RESET input sets this register to FFH.

Figure 9-7. Format of Port Mode Register 2

Symbol	7	6	5	4	3	2	1	0	Address	After reset	R/W
PM2	1	1	1	1	1	1	PM21	PM20	FF22H	FFH	R/W

PM2m	P2m pin input/output mode (m = 0, 1)
0	Output mode (output buffer on)
1	Input mode (output buffer off)

9.4 8-Bit Timers 30 and 40 Operation

9.4.1 Operation as 8-bit timer counter

Timer 30 and timer 40 can independently be used as an 8-bit timer counter. The following modes can be used for the 8-bit timer counter.

- Interval timer with 8-bit resolution
- External event counter with 8-bit resolution (timer 40 only)
- Square wave output with 8-bit resolution (timer 40 only)

(1) Operation as interval timer with 8-bit resolution

The interval timer with 8-bit resolution repeatedly generates an interrupt at a time interval specified by the count value preset in 8-bit compare register n0 (CRn0).

To operate 8-bit timer n0 as an interval timer, settings must be made in the following sequence.

- <1> Disable operation of 8-bit timer counter n0 (TMn0) (TCEn0 = 0).
- <2> Disable timer output of TMO (TOE40 = 0)^{Note}.
- <3> Set a count value in CRn0.
- <4> Set the operation mode of timer n0 to 8-bit timer counter mode (see **Figures 9-4** and **9-5**).
- <5> Set the count clock for timer n0 (see **Tables 9-3** to **9-6**).
- <6> Enable the operation of TMn0 (TCEn0 = 1).

When the count value of 8-bit timer counter n0 (TMn0) matches the value set in CRn0, TMn0 is cleared to 0 and continues counting. At the same time, an interrupt request signal (INTTMn0) is generated.

Tables 9-3 to 9-6 show interval time, and Figures 9-8 to 9-13 show the timing of the interval timer operation.

Note Timer 40 only

Caution Be sure to stop the timer operation before overwriting the count clock with different data.

Remark n = 3, 4

Table 9-3. Interval Time of Timer 30 (During $f_x = 5.0$ MHz Operation)

TCL302	TCL301	TCL300	Minimum Interval Time	Maximum Interval Time	Resolution
0	0	0	$2^6/f_x$ (12.8 μ s)	$2^{14}/f_x$ (3.28 ms)	$2^9/f_x$ (12.8 μ s)
0	0	1	$2^8/f_x$ (51.2 μ s)	$2^{16}/f_x$ (13.1 ms)	$2^9/f_x$ (51.2 μ s)
0	1	0	Input cycle of timer 40 match signal	Input cycle of timer 40 match signal $\times 2^8$	Input cycle of timer 40 match signal
0	1	1	Carrier clock cycle generated by timer 40	Carrier clock cycle generated by timer 40 $\times 2^8$	Carrier clock cycle generated by timer 40

Remark f_x : System clock oscillation frequency (ceramic/crystal oscillation)

Table 9-4. Interval Time of Timer 30 (During $f_{cc} = 1.0$ MHz Operation)

TCL302	TCL301	TCL300	Minimum Interval Time	Maximum Interval Time	Resolution
0	0	0	$2^6/f_{cc}$ (64 μ s)	$2^{14}/f_{cc}$ (16.4 ms)	$2^9/f_{cc}$ (64 μ s)
0	0	1	$2^8/f_{cc}$ (256 μ s)	$2^{16}/f_{cc}$ (65.5 ms)	$2^9/f_{cc}$ (256 μ s)
0	1	0	Input cycle of timer 40 match signal	Input cycle of timer 40 match signal $\times 2^8$	Input cycle of timer 40 match signal
0	1	1	Carrier clock cycle generated by timer 40	Carrier clock cycle generated by timer 40 $\times 2^8$	Carrier clock cycle generated by timer 40

Remark f_{cc} : System clock oscillation frequency (RC oscillation)

Table 9-5. Interval Time of Timer 40 (During $f_x = 5.0$ MHz Operation)

TCL402	TCL401	TCL400	Minimum Interval Time	Maximum Interval Time	Resolution
0	0	0	$1/f_x$ (0.2 μ s)	$2^9/f_x$ (51.2 μ s)	$1/f_x$ (0.2 μ s)
0	0	1	$2^2/f_x$ (0.8 μ s)	$2^{10}/f_x$ (204.8 μ s)	$2^2/f_x$ (0.8 μ s)
0	1	0	f_{TMI} input cycle	f_{TMI} input cycle $\times 2^8$	f_{TMI} input cycle
0	1	1	$f_{TMI}/2$ input cycle	$f_{TMI}/2$ input cycle $\times 2^8$	$f_{TMI}/2$ input cycle
1	0	0	$f_{TMI}/2^2$ input cycle	$f_{TMI}/2^2$ input cycle $\times 2^8$	$f_{TMI}/2^2$ input cycle
1	0	1	$f_{TMI}/2^3$ input cycle	$f_{TMI}/2^3$ input cycle $\times 2^8$	$f_{TMI}/2^3$ input cycle

Remark f_x : System clock oscillation frequency (ceramic/crystal oscillation)

Table 9-6. Interval Time of Timer 40 (During $f_{cc} = 1.0$ MHz Operation)

TCL402	TCL401	TCL400	Minimum Interval Time	Maximum Interval Time	Resolution
0	0	0	$1/f_{cc}$ (1.0 μ s)	$2^9/f_{cc}$ (256 μ s)	$1/f_{cc}$ (1.0 μ s)
0	0	1	$2^2/f_{cc}$ (4.0 μ s)	$2^{10}/f_{cc}$ (1024 μ s)	$2^2/f_{cc}$ (4.0 μ s)
0	1	0	f_{TMI} input cycle	f_{TMI} input cycle $\times 2^8$	f_{TMI} input cycle
0	1	1	$f_{TMI}/2$ input cycle	$f_{TMI}/2$ input cycle $\times 2^8$	$f_{TMI}/2$ input cycle
1	0	0	$f_{TMI}/2^2$ input cycle	$f_{TMI}/2^2$ input cycle $\times 2^8$	$f_{TMI}/2^2$ input cycle
1	0	1	$f_{TMI}/2^3$ input cycle	$f_{TMI}/2^3$ input cycle $\times 2^8$	$f_{TMI}/2^3$ input cycle

Remark f_{cc} : System clock oscillation frequency (RC oscillation)

Figure 9-8. Timing of Interval Timer Operation with 8-Bit Resolution (Basic Operation)

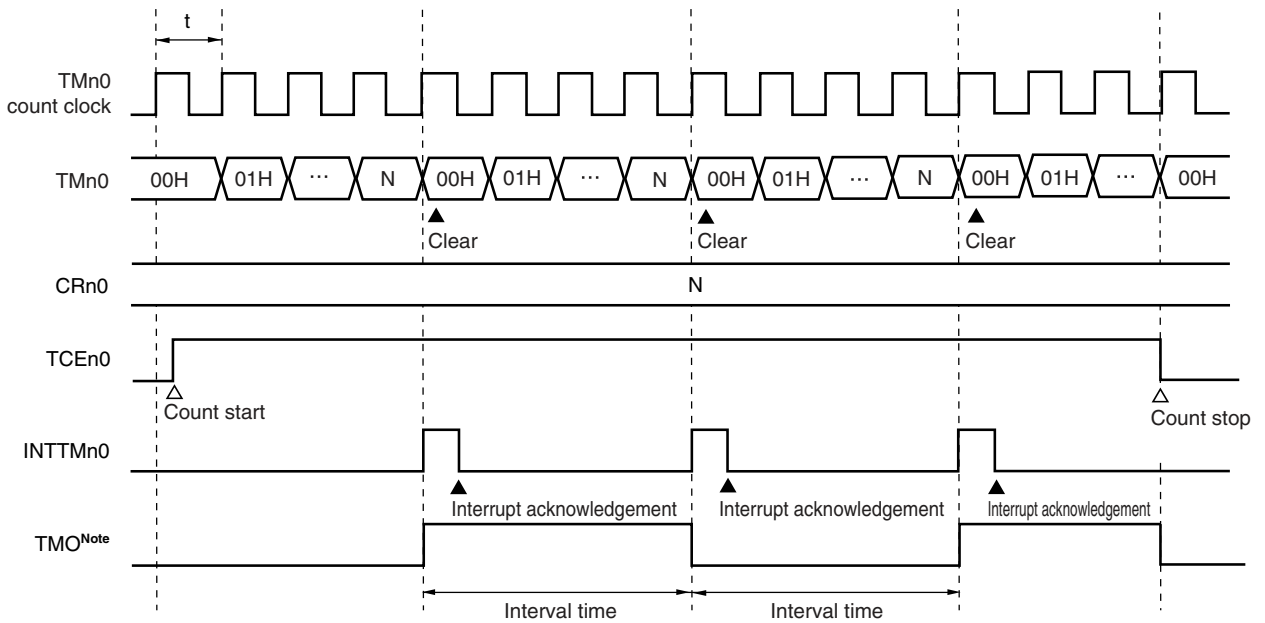

Note Timer 40 only

- Remarks**
- Interval time: $(N + 1) \times t$; $N = 00H$ to FFH
 - $n = 3, 4$

Figure 9-9. Timing of Interval Timer Operation with 8-Bit Resolution (When CRn0 Is Set to 00H)

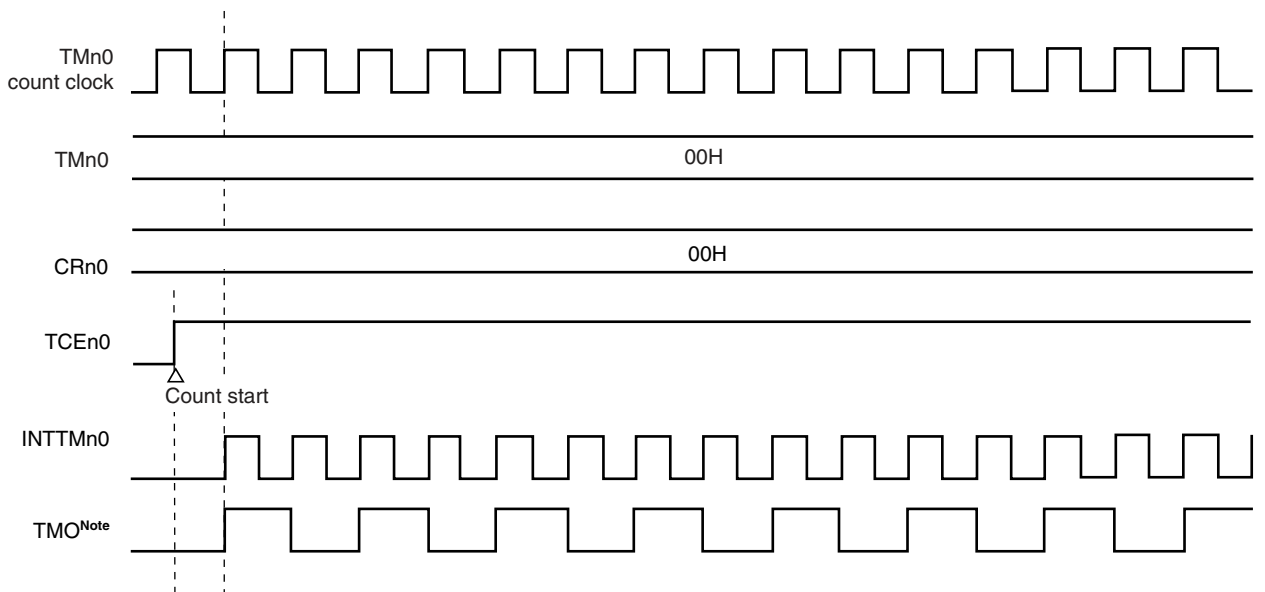

Note Timer 40 only

Remark $n = 3, 4$

Figure 9-10. Timing of Interval Timer Operation with 8-Bit Resolution (When CRn0 Is Set to FFH)

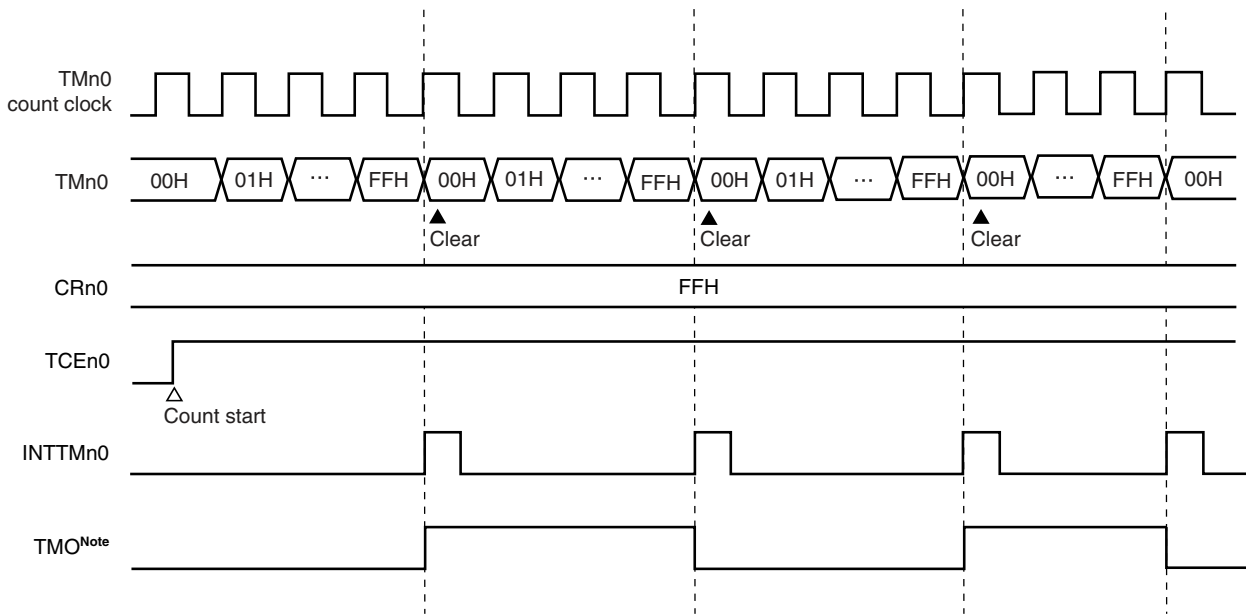

Note Timer 40 only

Remark n = 3, 4

Figure 9-11. Timing of Interval Timer Operation with 8-Bit Resolution (When CRn0 Changes from N to M (N < M))

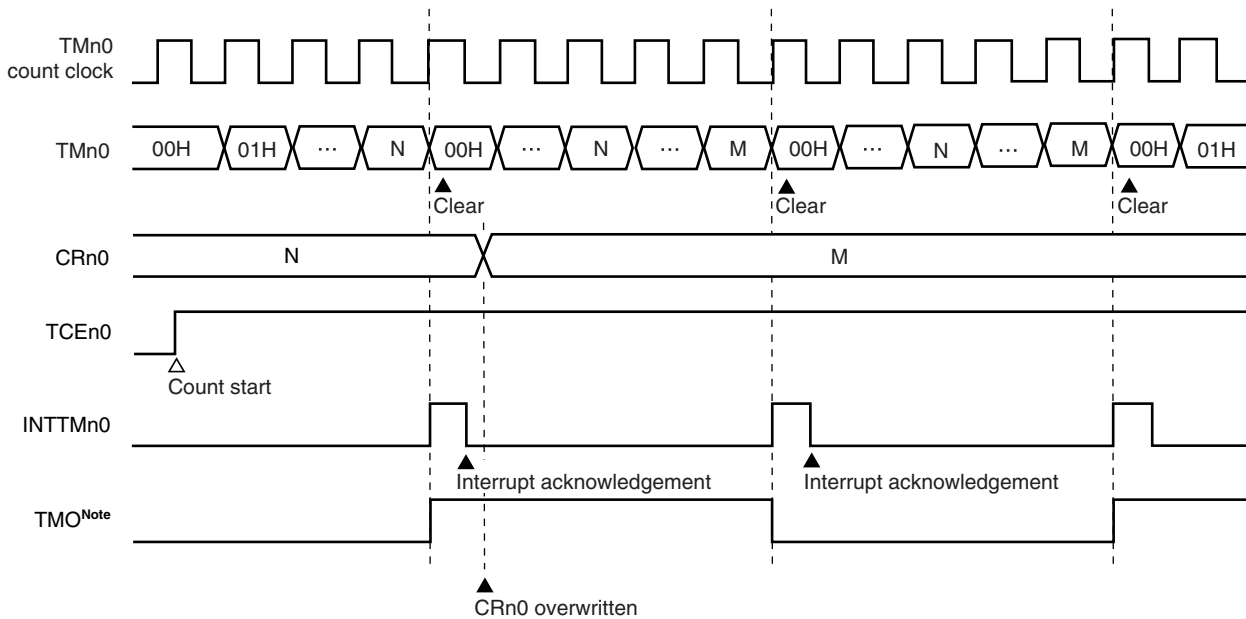

Note Timer 40 only

Remark n = 3, 4

**Figure 9-12. Timing of Interval Timer Operation with 8-Bit Resolution
(When CRn0 Changes from N to M (N > M))**

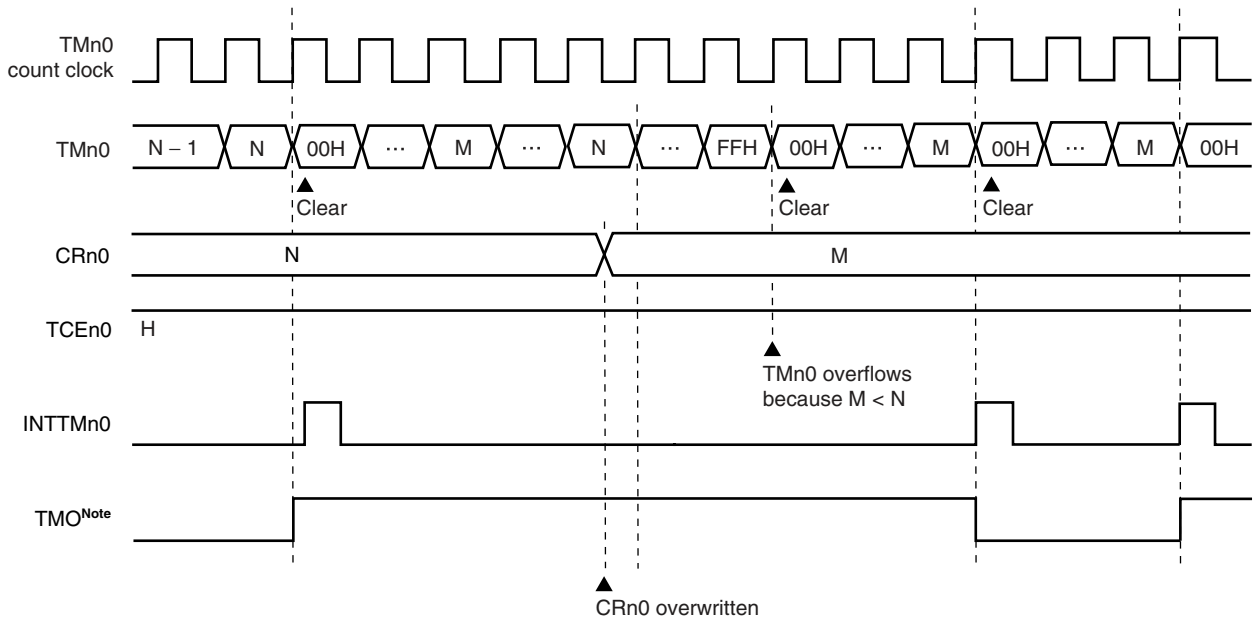

Note Timer 40 only

Remark n = 3, 4

**Figure 9-13. Timing of Interval Timer Operation with 8-Bit Resolution
(When Timer 40 Match Signal Is Selected for Timer 30 Count Clock)**

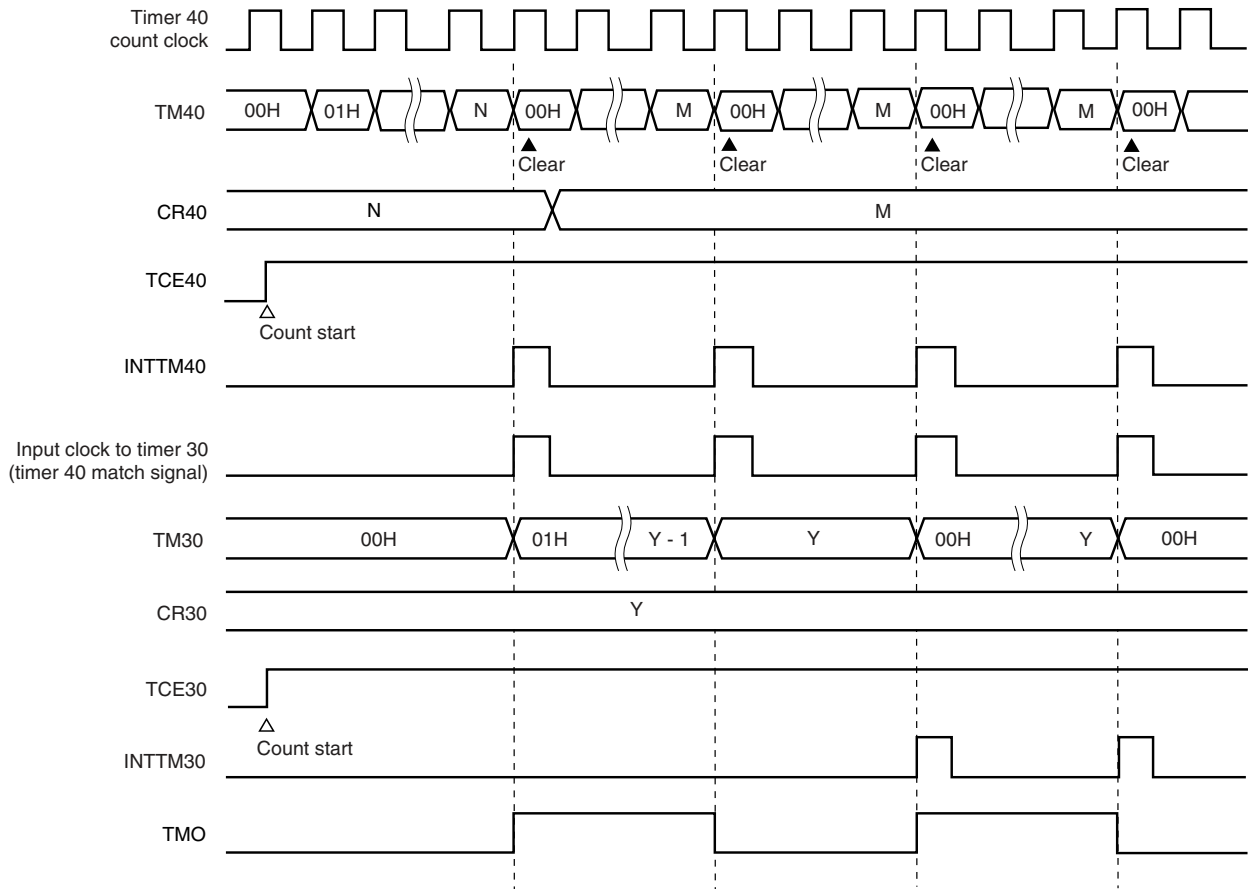

Remark n = 3, 4

(2) Operation as external event counter with 8-bit resolution (timer 40 only)

The external event counter counts the number of external clock pulses input to the TMI/P21 pin by using 8-bit timer counter 40 (TM40).

To operate timer 40 as an external event counter, settings must be made in the following sequence.

- <1> Disable operation of 8-bit timer counter 40 (TM40) (TCE40 = 0).
- <2> Disable timer output of TMO (TOE40 = 0).
- <3> Set P21 to input mode (PM21 = 1).
- <4> Select the external input clock for timer 40 (see **Tables 9-5** and **9-6**).
- <5> Set the operation mode of timer 40 to 8-bit timer counter mode (see **Figures 9-4** and **9-5**).
- <6> Set a count value in CR40.
- <7> Enable the operation of TM40 (TCE40 = 1).

Each time the valid edge is input, the value of TM40 is incremented.

When the count value of TM40 matches the value set in CR40, TM40 is cleared to 00H and continues counting. At the same time, an interrupt request signal (INTTM40) is generated.

Figure 9-14 shows the timing of the external event counter operation.

Caution Be sure to stop the timer operation before overwriting the count clock with different data.

Figure 9-14. Timing of Operation of External Event Counter with 8-Bit Resolution

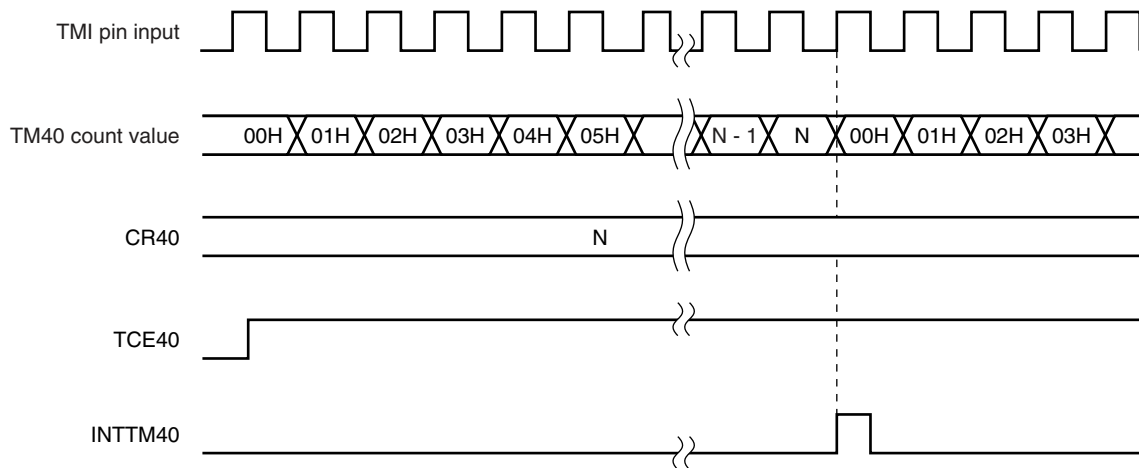

Remark N = 00H to FFH

(3) Operation as square-wave output with 8-bit resolution (timer 40 only)

Square waves of any frequency can be output at an interval specified by the value preset in 8-bit compare register 40 (CR40).

To operate timer 40 for square-wave output, settings must be made in the following sequence.

- <1> Set P20 to output mode (PM20 = 0).
- <2> Set the output latches of P20 to 0.
- <3> Disable operation of 8-bit timer counter 40 (TM40) (TCE40 = 0).
- <4> Set a count clock for timer 40 and enable output of TMO (TOE40 = 1).
- <5> Set a count value in CR40.
- <6> Enable the operation of TM40 (TCE40 = 1).

When the count value of TM40 matches the value set in CR40, the TMO pin output will be inverted. Through application of this mechanism, square waves of any frequency can be output. As soon as a match occurs, TM40 is cleared to 00H and continues counting. At the same time, an interrupt request signal (INTTM40) is generated.

The square-wave output is cleared to 0 by setting TCE40 to 0.

Tables 9-7 and 9-8 show the square-wave output range, and Figure 9-15 shows the timing of square-wave output.

Caution Be sure to stop the timer operation before overwriting the count clock with different data.

Table 9-7. Square-Wave Output Range of Timer 40 (During $f_x = 5.0$ MHz Operation)

TCL402	TCL401	TCL400	Minimum Pulse Width	Maximum Pulse Width	Resolution
0	0	0	$1/f_x$ (0.2 μ s)	$2^8/f_x$ (51.2 μ s)	$1/f_x$ (0.2 μ s)
0	0	1	$2^2/f_x$ (0.8 μ s)	$2^{10}/f_x$ (204.8 μ s)	$2^2/f_x$ (0.8 μ s)

Remark f_x : System clock oscillation frequency (ceramic/crystal oscillation)

Table 9-8. Square-Wave Output Range of Timer 40 (During $f_{cc} = 1.0$ MHz Operation)

TCL402	TCL401	TCL400	Minimum Pulse Width	Maximum Pulse Width	Resolution
0	0	0	$1/f_{cc}$ (1.0 μ s)	$2^8/f_{cc}$ (256 μ s)	$1/f_{cc}$ (1.0 μ s)
0	0	1	$2^2/f_{cc}$ (4.0 μ s)	$2^{10}/f_{cc}$ (1024 μ s)	$2^2/f_{cc}$ (4.0 μ s)

Remark f_{cc} : System clock oscillation frequency (RC oscillation)

Figure 9-15. Timing of Square-Wave Output with 8-Bit Resolution

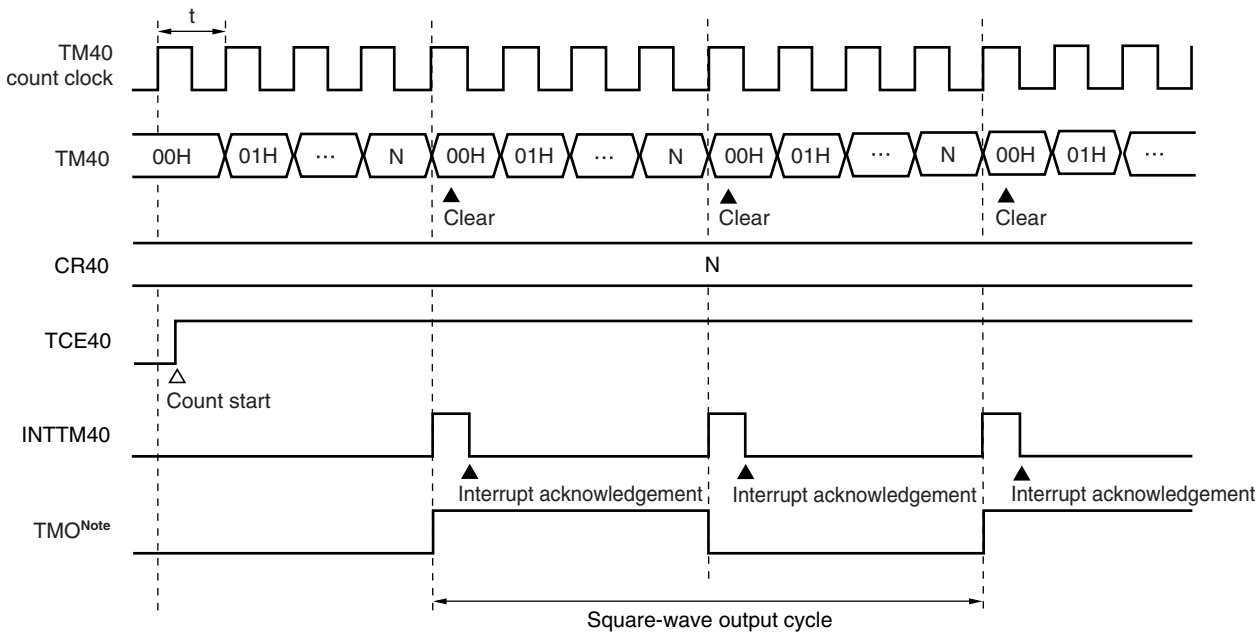

Note The initial value of TMO is low level when output is enabled (TOE40 = 1).

Remark Square-wave output cycle = $2(N+1) \times t$
 N = 00H to FFH

9.4.2 Operation as 16-bit timer counter

Timer 30 and timer 40 can be used as a 16-bit timer counter using cascade connection. In this case, 8-bit timer counter 30 (TM30) is the higher 8 bits and 8-bit timer counter 40 (TM40) is the lower 8 bits. 8-bit timer 40 controls reset and clear.

The following modes can be used for the 16-bit timer counter.

- Interval timer with 16-bit resolution
- External event counter with 16-bit resolution
- Square wave output with 16-bit resolution

(1) Operation as interval timer with 16-bit resolution

The interval timer with 16-bit resolution repeatedly generates an interrupt at a time interval specified by the count value preset in 8-bit compare register 30 (CR30) and 8-bit compare register 40 (CR40).

To operate as an interval timer with 16-bit resolution, settings must be made in the following sequence.

- <1> Disable operation of 8-bit timer counter 30 (TM30) and 8-bit timer counter 40 (TM40) (TCE30 = 0, TCE40 = 0).
- <2> Disable timer output of TMO (TOE40 = 0)^{Note 1}.
- <3> Set the count clock for timer 40 (see **Tables 9-9** and **9-10**).
- <4> Set the operation mode of timer 30 and timer 40 to 16-bit timer counter mode (see **Figures 9-4** and **9-5**).
- <5> Set a count value in CR30 and CR40.
- <6> Enable the operation of TM30 and TM40 (TCE40 = 1^{Note 2}).

- Notes**
1. Timer 40 only
 2. Start and clear of the timer in the 16-bit timer counter mode are controlled by TCE40 (the value of TCE30 is invalid).

When the count values of TM30 and TM40 match the values set in CR30 and CR40 respectively, both TM30 and TM40 are simultaneously cleared to 00H and counting continues. At the same time, an interrupt request signal (INTTM40) is generated (INTTM30 is not generated).

Tables 9-9 and 9-10 show interval time, and Figure 9-16 shows the timing of the interval timer operation.

Caution Be sure to stop the timer operation before overwriting the count clock with different data.

Table 9-9. Interval Time with 16-Bit Resolution (During $f_x = 5.0$ MHz Operation)

TCL402	TCL401	TCL400	Minimum Interval Time	Maximum Interval Time	Resolution
0	0	0	$1/f_x$ (0.2 μ s)	$2^{16}/f_x$ (13.1 ms)	$1/f_x$ (0.2 μ s)
0	0	1	$2^2/f_x$ (0.8 μ s)	$2^{18}/f_x$ (52.4 ms)	$2^2/f_x$ (0.8 μ s)
0	1	0	f_{TMI} input cycle	f_{TMI} input cycle $\times 2^{16}$	f_{TMI} input cycle
0	1	1	$f_{TMI}/2$ input cycle	$f_{TMI}/2$ input cycle $\times 2^{16}$	$f_{TMI}/2$ input cycle
1	0	0	$f_{TMI}/2^2$ input cycle	$f_{TMI}/2^2$ input cycle $\times 2^{16}$	$f_{TMI}/2^2$ input cycle
1	0	1	$f_{TMI}/2^3$ input cycle	$f_{TMI}/2^3$ input cycle $\times 2^{16}$	$f_{TMI}/2^3$ input cycle

Remark f_x : System clock oscillation frequency (ceramic/crystal oscillation)

Table 9-10. Interval Time with 16-Bit Resolution (During $f_{cc} = 1.0$ MHz Operation)

TCL402	TCL401	TCL400	Minimum Interval Time	Maximum Interval Time	Resolution
0	0	0	$1/f_{cc}$ (1.0 μ s)	$2^{16}/f_{cc}$ (65.5 ms)	$1/f_{cc}$ (1.0 μ s)
0	0	1	$2^2/f_{cc}$ (4.0 μ s)	$2^{18}/f_{cc}$ (262.1 ms)	$2^2/f_{cc}$ (4.0 μ s)
0	1	0	f_{TMI} input cycle	f_{TMI} input cycle $\times 2^{16}$	f_{TMI} input cycle
0	1	1	$f_{TMI}/2$ input cycle	$f_{TMI}/2$ input cycle $\times 2^{16}$	$f_{TMI}/2$ input cycle
1	0	0	$f_{TMI}/2^2$ input cycle	$f_{TMI}/2^2$ input cycle $\times 2^{16}$	$f_{TMI}/2^2$ input cycle
1	0	1	$f_{TMI}/2^3$ input cycle	$f_{TMI}/2^3$ input cycle $\times 2^{16}$	$f_{TMI}/2^3$ input cycle

Remark f_{cc} : System clock oscillation frequency (RC oscillation)

Figure 9-16. Timing of Interval Timer Operation with 16-Bit Resolution

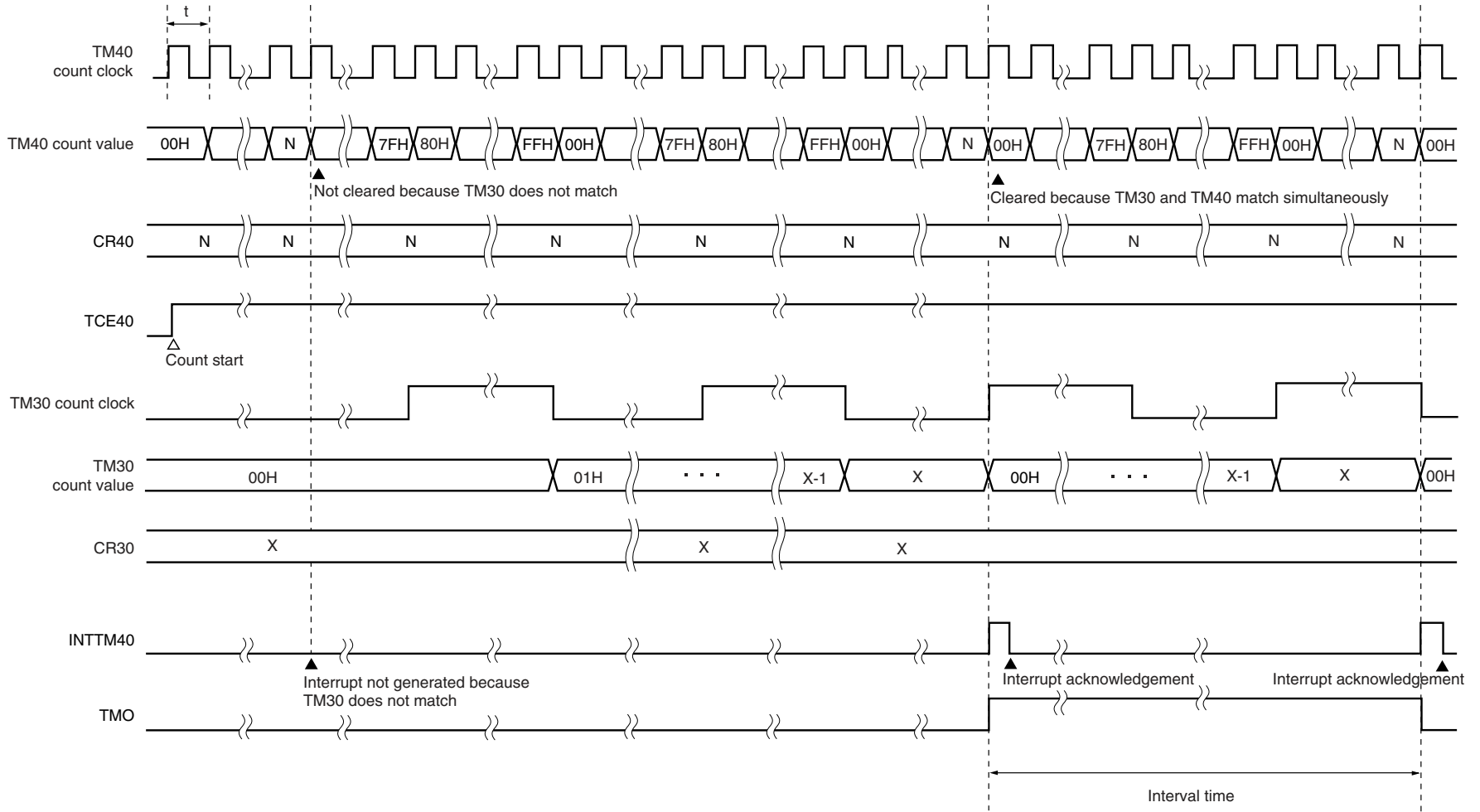

Remark Interval time: $(256X + N + 1) \times t$: X = 00H to FFH, N = 00H to FFH

(2) Operation as external event counter with 16-bit resolution

The external event counter counts the number of external clock pulses input to the TMI/P21 pin by TM30 and TM40.

To operate as an external event counter with 16-bit resolution, settings must be made in the following sequence.

- <1> Disable operation of TM30 and TM40 ($TCE30 = 0$, $TCE40 = 0$).
- <2> Disable timer output of TMO ($TOE40 = 0$)^{Note 1}.
- <3> Set P21 to input mode ($PM21 = 1$).
- <4> Select the external input clock for timer 40 (see **Tables 9-9** and **9-10**).
- <5> Set the operation mode of timer 30 and timer 40 to 16-bit timer counter mode (see **Figures 9-4** and **9-5**).
- <6> Set a count value in CR30 and CR40.
- <7> Enable the operation of TM30 and TM40 ($TCE40 = 1$)^{Note 2}.

Notes 1. Timer 40 only

- 2. Start and clear of the timer in the 16-bit timer counter mode are controlled by TCE40 (the value of TCE30 is invalid).

Each time the valid edge is input, the values of TM30 and TM40 are incremented.

When the count values of TM30 and TM40 match the values set in CR30 and CR40 respectively, both TM30 and TM40 are simultaneously cleared to 00H and counting continues. At the same time, an interrupt request signal (INTTM40) is generated (INTTM30 is not generated).

Figure 9-17 shows the timing of the external event counter operation.

Caution Be sure to stop the timer operation before overwriting the count clock with different data.

Figure 9-17. Timing of External Event Counter Operation with 16-Bit Resolution

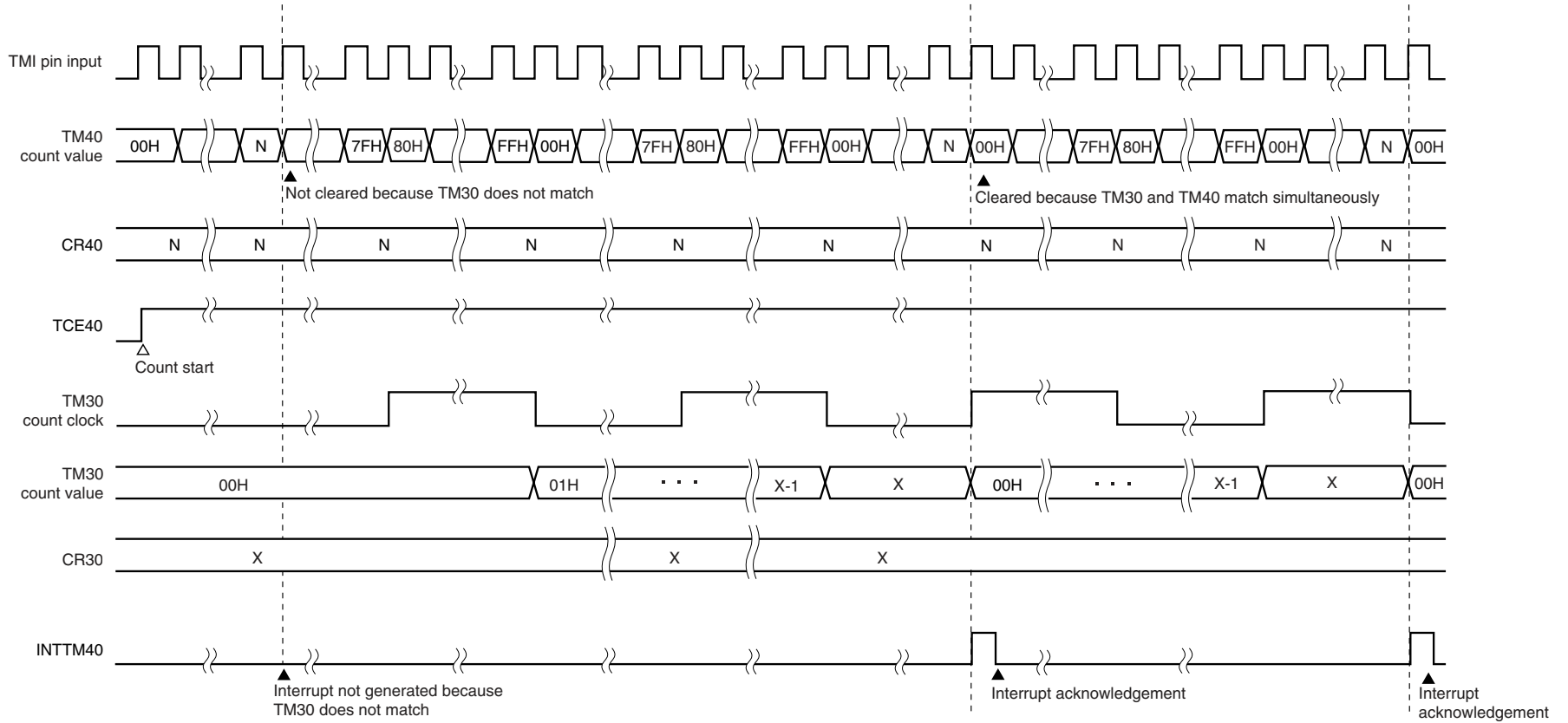

Remark X = 00H to FFH, N = 00H to FFH

(3) Operation as square-wave output with 16-bit resolution

Square waves of any frequency can be output at an interval specified by the count value preset in CR30 and CR40.

To operate as a square-wave output with 16-bit resolution, settings must be made in the following sequence.

- <1> Disable operation of TM30 and TM40 ($TCE30 = 0$, $TCE40 = 0$).
- <2> Disable output of TMO ($TOE40 = 0$).
- <3> Set a count clock for timer 40.
- <4> Set P20 to output mode ($PM20 = 0$) and P20 output latch to 0 and enable TMO output ($TOE40 = 1$).
- <5> Set count values in CR30 and CR40.
- <6> Enable the operation of TM40 ($TCE40 = 1$ ^{Note}).

Note Start and clear of the timer in the 16-bit timer counter mode are controlled by TCE40 (the value of TCE30 is invalid).

When the count values of TM30 and TM40 simultaneously match the values set in CR30 and CR40 respectively, the TMO pin output will be inverted. Through application of this mechanism, square waves of any frequency can be output. As soon as a match occurs, TM30 and TM40 are cleared to 00H and counting continues. At the same time, an interrupt request signal (INTTM40) is generated (INTTM30 is not generated). The square-wave output is cleared to 0 by setting TCE40 to 0.

Tables 9-11 and 9-12 show the square wave output range, and Figure 9-18 shows timing of square wave output.

Caution Be sure to stop the timer operation before overwriting the count clock with different data.

Table 9-11. Square-Wave Output Range with 16-Bit Resolution (During $f_x = 5.0$ MHz Operation)

TCL402	TCL401	TCL400	Minimum Pulse Time	Maximum Pulse Time	Resolution
0	0	0	$1/f_x$ (0.2 μ s)	$2^{16}/f_x$ (13.1 ms)	$1/f_x$ (0.2 μ s)
0	0	1	$2^2/f_x$ (0.8 μ s)	$2^{18}/f_x$ (52.4 ms)	$2^2/f_x$ (0.8 μ s)

Remark f_x : System clock oscillation frequency (ceramic/crystal oscillation)

Table 9-12. Square-Wave Output Range with 16-Bit Resolution (During $f_{cc} = 1.0$ MHz Operation)

TCL402	TCL401	TCL400	Minimum Pulse Time	Maximum Pulse Time	Resolution
0	0	0	$1/f_{cc}$ (1.0 μ s)	$2^{16}/f_{cc}$ (65.5 ms)	$1/f_{cc}$ (1.0 μ s)
0	0	1	$2^2/f_{cc}$ (4.0 μ s)	$2^{18}/f_{cc}$ (262.1 ms)	$2^2/f_{cc}$ (4.0 μ s)

Remark f_{cc} : System clock oscillation frequency (RC oscillation)

Figure 9-18. Timing of Square-Wave Output with 16-Bit Resolution

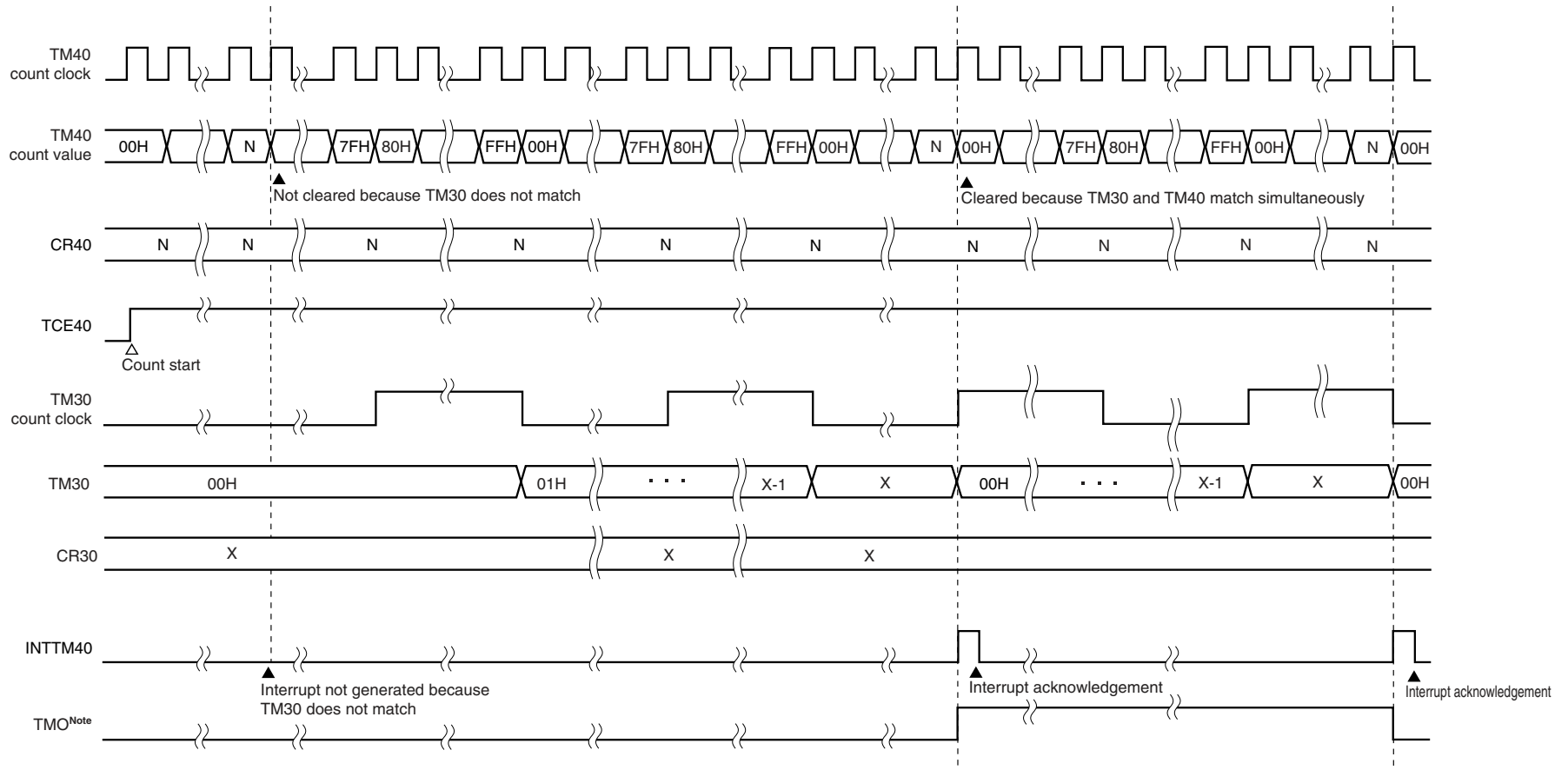

Note The initial value of TMO is low level when output is enabled (TOE40 = 1).

Remark X = 00H to FFH, N = 00H to FFH

9.4.3 Operation as carrier generator

An arbitrary carrier clock generated by TM40 can be output in the cycle set in TM30.

To operate timer 30 and timer 40 as carrier generators, setting must be made in the following sequence.

- <1> Disable operation of TM30 and TM40 (TCE30 = 0, TCE40 = 0).
- <2> Disable timer output of TMO (TOE40 = 0).
- <3> Set count values in CR30, CR40, and CRH40.
- <4> Set the operation mode of timer 40 to carrier generator mode (see **Figures 9-4** and **9-5**).
- <5> Set the count clock for timer 30 and timer 40.
- <6> Set remote control output to carrier pulse (RMC40 (bit 2 of carrier generator output control register 40 (TCA40)) = 0).
Input the required value to NRZB40 (bit 1 of TCA40) by program.
Input a value to NRZ40 (bit 0 of TCA40) before it is reloaded from NRZB40.
- <7> Set P20 to output mode (PM20 = 0) and the P20 output latch to 0 and enable TMO output by setting TOE40 to 1.
- <8> Enable the operation of TM30 and TM40 (TCE30 = 1, TCE40 = 1).
- <9> Save the value of NRZB40 to a general-purpose register.
- <10> When INTTM30 rises, the value of NRZB40 is transferred to NRZ40. After that, rewrite TCA40 with an 8-bit memory manipulation instruction. Input the value to be transferred to NRZ40 next time to NRZB40, and input the value saved in <9> to NRZ40.
- <11> Generate the desired carrier signal by repeating <9> and <10>.

The operation of the carrier generator is as follows.

- <1> When the count value of TM40 matches the value set in CR40, an interrupt request signal (INTTM40) is generated and output of timer 40 is inverted, which makes the compare register switch from CR40 to CRH40.
- <2> After that, when the count value of TM40 matches the value set in CRH40, an interrupt request signal (INTTM40) is generated and output of timer 40 is inverted again, which makes the compare register switch from CRH40 to CR40.
- <3> The carrier clock is generated by repeating <1> and <2> above.
- <4> When the count value of TM30 matches the value set in CR30, an interrupt request signal (INTTM30) is generated. The rising edge of INTTM30 is the data reload signal of NRZB40 and is transferred to NRZ40.
- <5> When NRZ40 is 1, a carrier clock is output from TMO pin.

Cautions 1. TCA40 cannot be set with a 1-bit memory manipulation instruction. Be sure to use an 8-bit memory manipulation instruction to set TCA40.

2. **The NRZ40 flag can be written only when carrier generator output is stopped (TOE40 = 0). The data cannot be overwritten when TOE40 = 1.**
3. **When the carrier generator is stopped once and then started again, NRZB40 does not hold the previous data. Re-set data to NRZB40. At this time, a 1-bit memory manipulation instruction must not be used. Be sure to use an 8-bit memory manipulation instruction.**
4. **To enable operation in the carrier generator mode, set a value to the compare registers (CR30, CR40, and CRH40), and input the necessary value to the NRZB40 and NRZ40 flags in advance. Otherwise, the signal of the timer match circuit will become unstable and the NRZ40 flag will be undefined.**
5. **Note that the μ PD78E9860 and 78E9861 have the following restrictions (which do not apply to the mask ROM version and the μ PD78E9860A and 78E9861A).**
 - (a) **While INTTM30 (interrupt generated by the match signal of timer 30) is being output, accessing TCA40 is prohibited.**
 - (b) **Accessing TCA40 is prohibited while 8-bit timer/counter 30 (TM30) is 00H. To access TCA40 while TM30 = 00H, wait for more than half a period of the TM30 count clock and then rewrite TCA40.**

Figures 9-19 to 9-21 show the operation timing of the carrier generator.

Figure 9-19. Timing of Carrier Generator Operation (When CR40 = N, CRH40 = M (M > N))

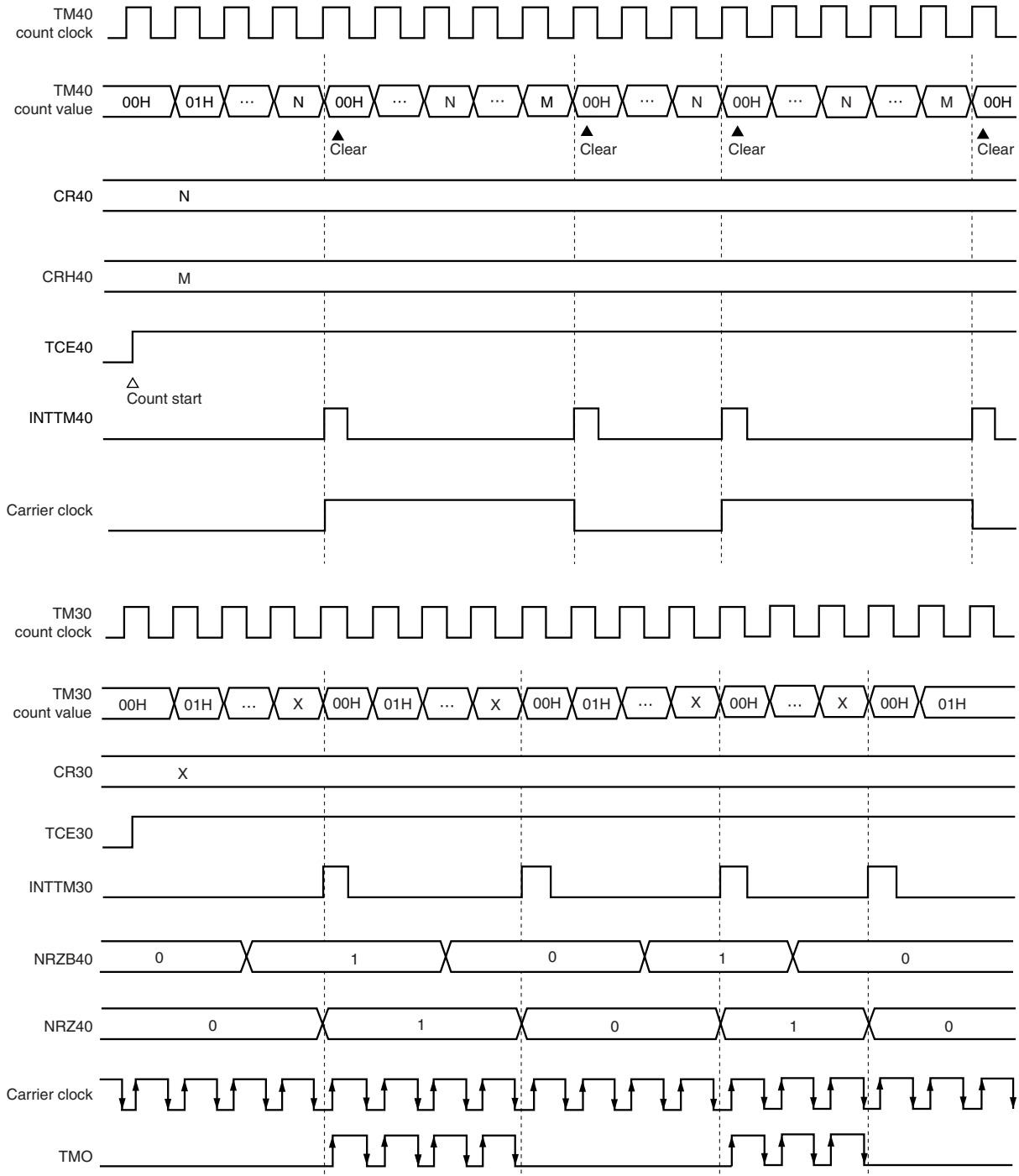
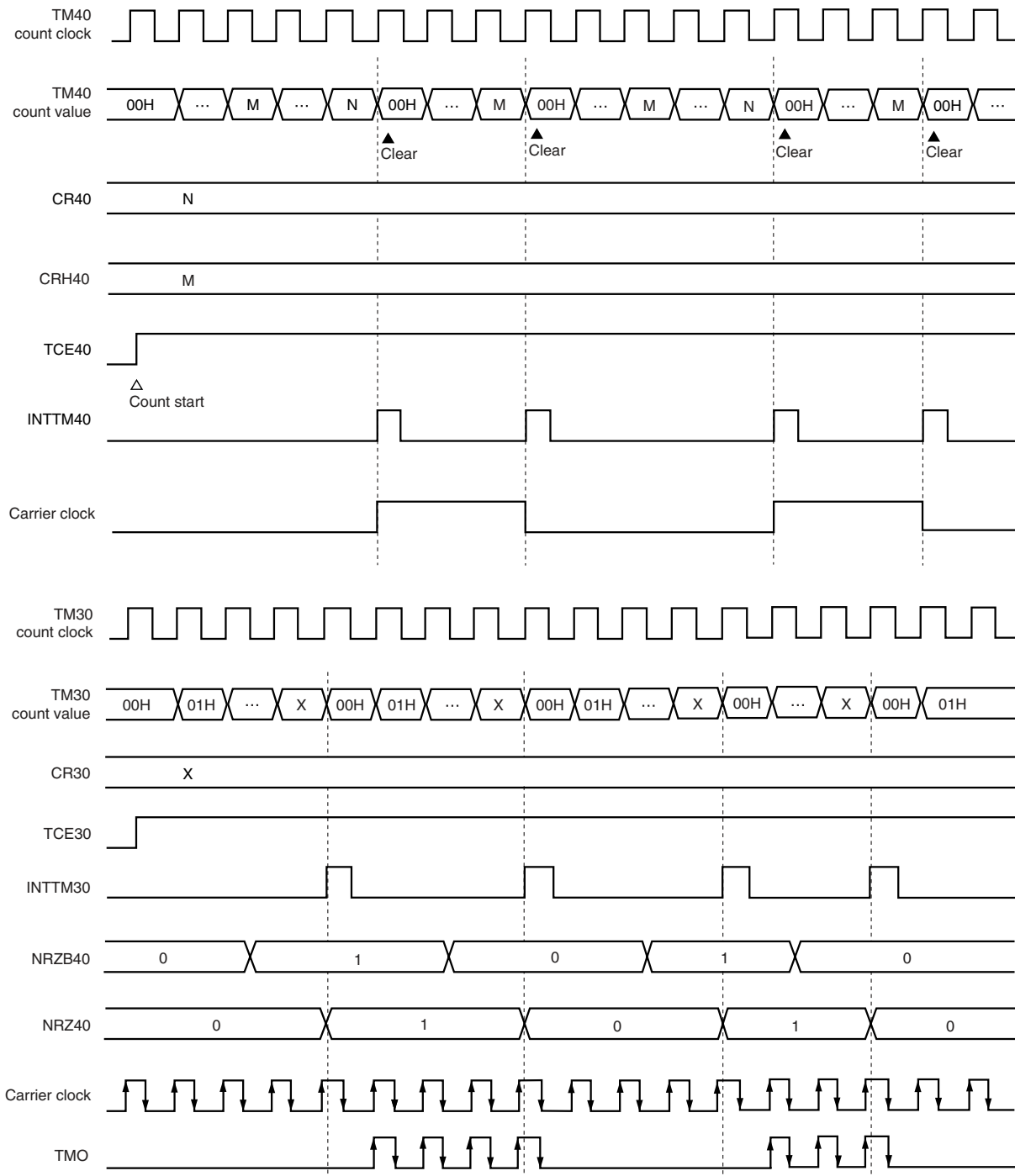
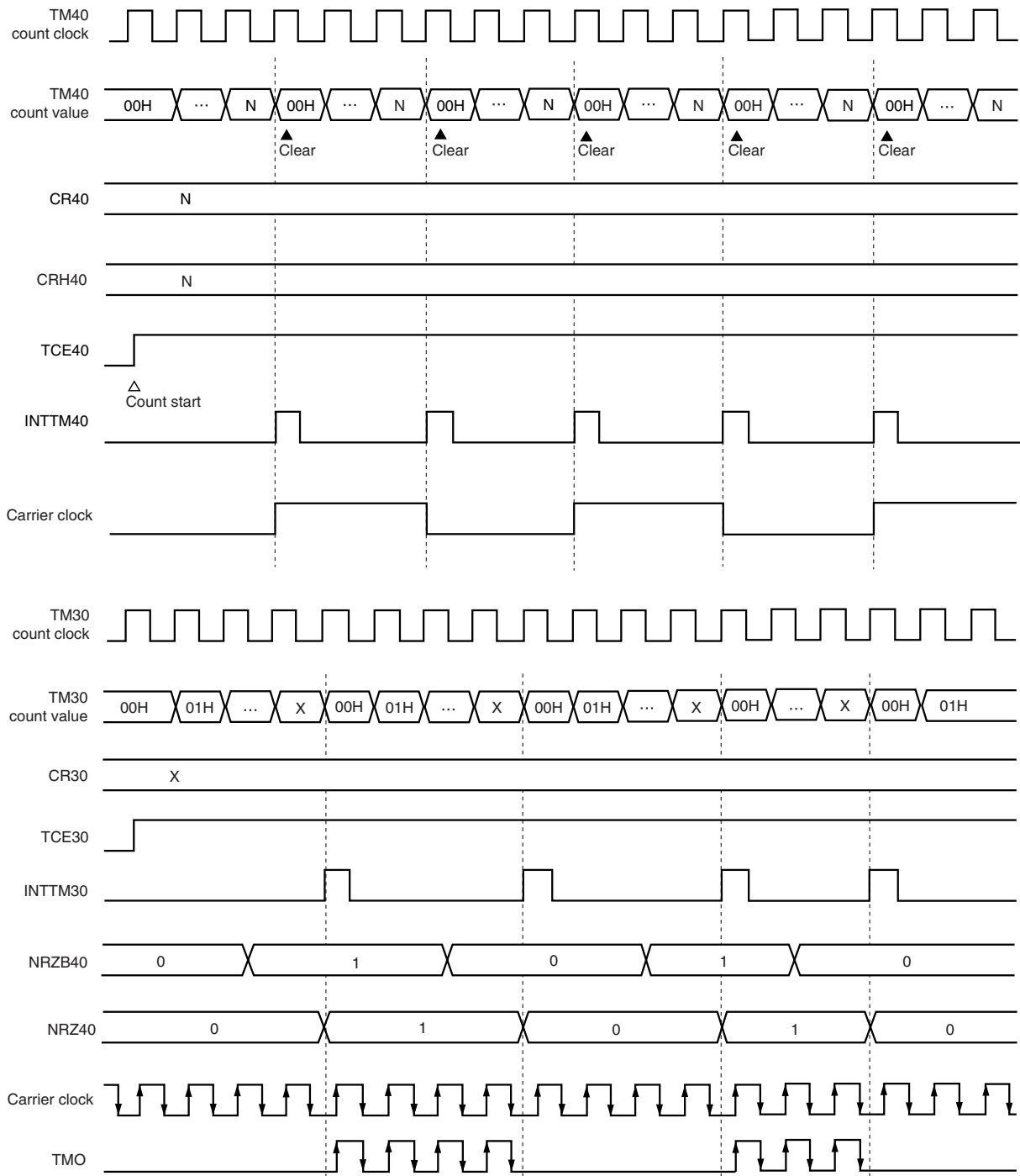

Figure 9-20. Timing of Carrier Generator Operation (When CR40 = N, CRH40 = M (M < N))



Remark This timing chart shows an example in which the value of NRZ40 is changed while the carrier clock is high.

Figure 9-21. Timing of Carrier Generator Operation (When CR40 = CRH40 = N)



9.4.4 Operation as PWM output (timer 40 only)

In the PWM output mode, a pulse of any duty ratio can be output by setting a low-level width using CR40 and a high-level width using CRH40.

To operate timer 40 in PWM output mode, settings must be made in the following sequence.

- <1> Disable operation of TM40 (TCE40 = 0).
- <2> Disable timer output of TMO (TOE40 = 0).
- <3> Set count values in CR40 and CRH40.
- <4> Set the operation mode of timer 40 to PWM output mode (see **Figure 9-5**).
- <5> Set the count clock for timer 40.
- <6> Set P20 to output mode (PM20 = 0) and the P20 output latch to 0 and enable timer output of TMO (TOE40 = 1).
- <7> Enable the operation of TM40 (TCE40 = 1).

The operation in the PWM output mode is as follows.

- <1> When the count value of TM40 matches the value set in CR40, an interrupt request signal (INTTM40) is generated and output of timer 40 is inverted, which makes the compare register switch from CR40 to CRH40.
- <2> A match between TM40 and CR40 clears the TM40 value to 00H and then counting starts again.
- <3> After that, when the count value of TM40 matches the value set in CRH40, an interrupt request signal (INTTM40) is generated and output of timer 40 is inverted again, which makes the compare register switch from CRH40 to CR40.
- <4> A match between TM40 and CRH40 clears the TM40 value to 00H and then counting starts again.

A pulse of any duty ratio is output by repeating <1> to <4> above. Figures 9-22 and 9-23 show the operation timing in the PWM output mode.

Figure 9-22. PWM Output Mode Timing (Basic Operation)

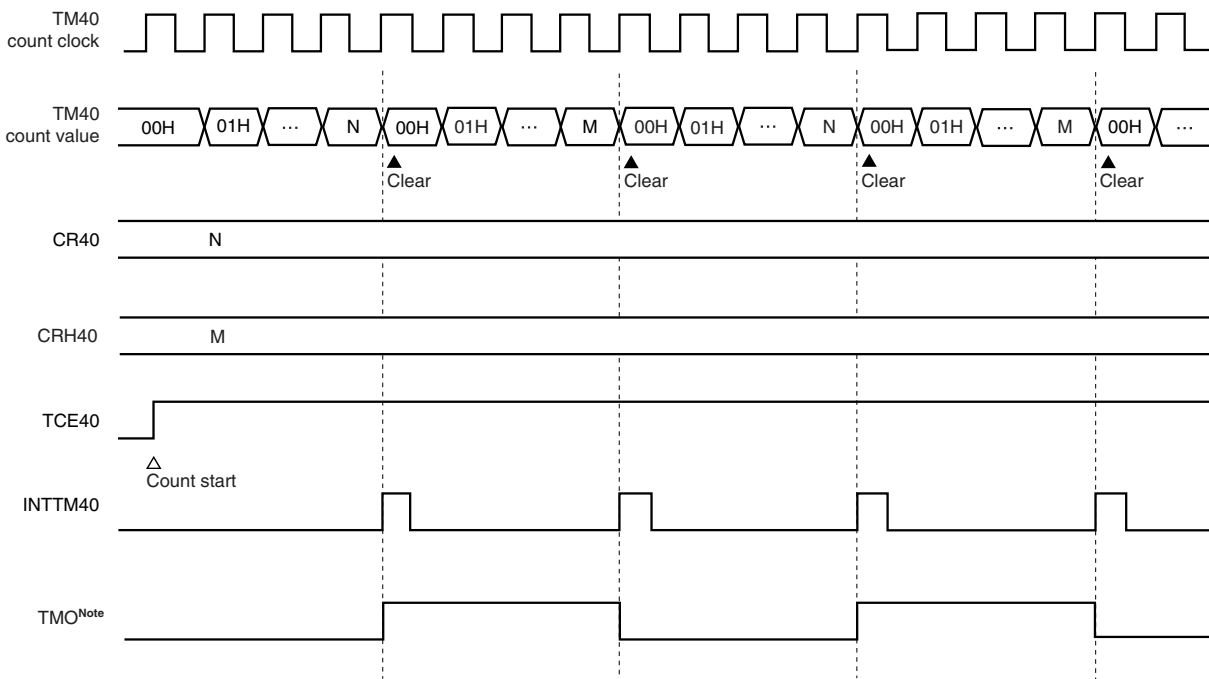

Note The initial value of TMO is low level when output is enabled (TOE40 = 1).

Figure 9-23. PWM Output Mode Timing (When CR40 and CRH40 Are Overwritten)

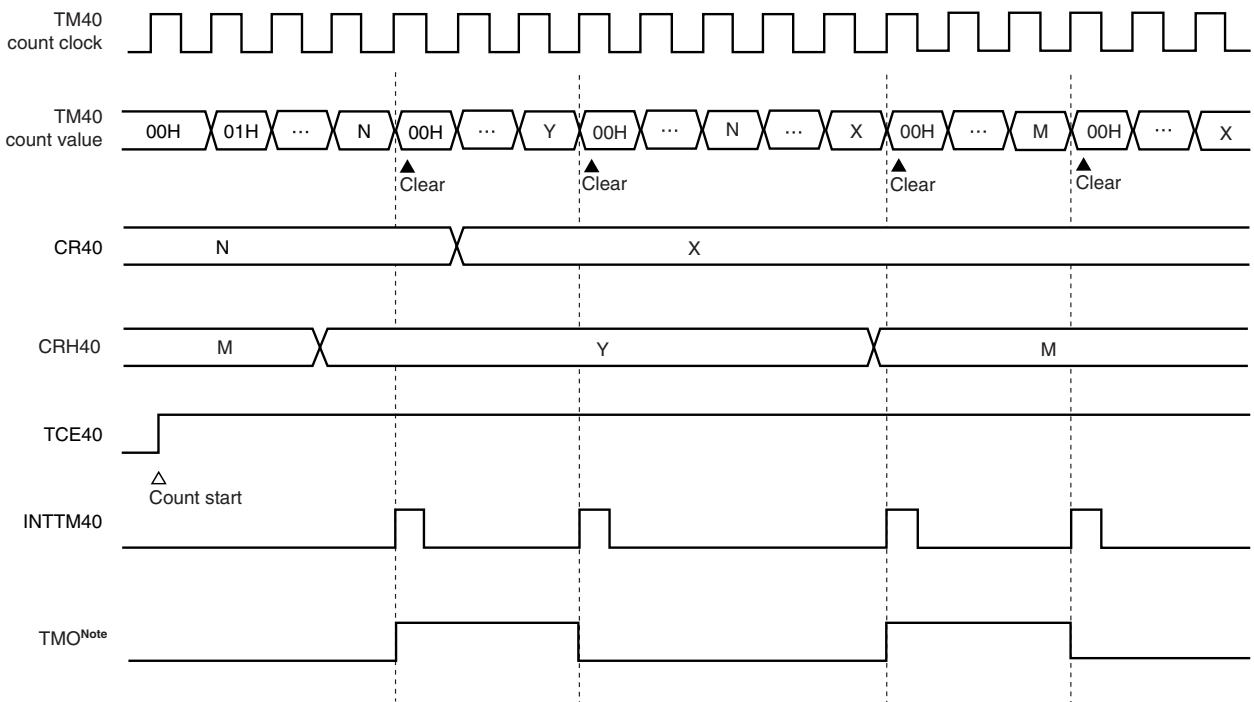

Note The initial value of TMO is low level when output is enabled (TOE40 = 1).

9.5 Notes on Using 8-Bit Timers 30 and 40

(1) Error on starting timer

An error of up to 1.5 clocks is included in the time between the timer being started and a match signal being generated. This is because the rising edge is detected and the counter is incremented if the timer is started while the count clock is high (see **Figure 9-24**).

Figure 9-24. Case of Error Occurrence of up to 1.5 Clocks

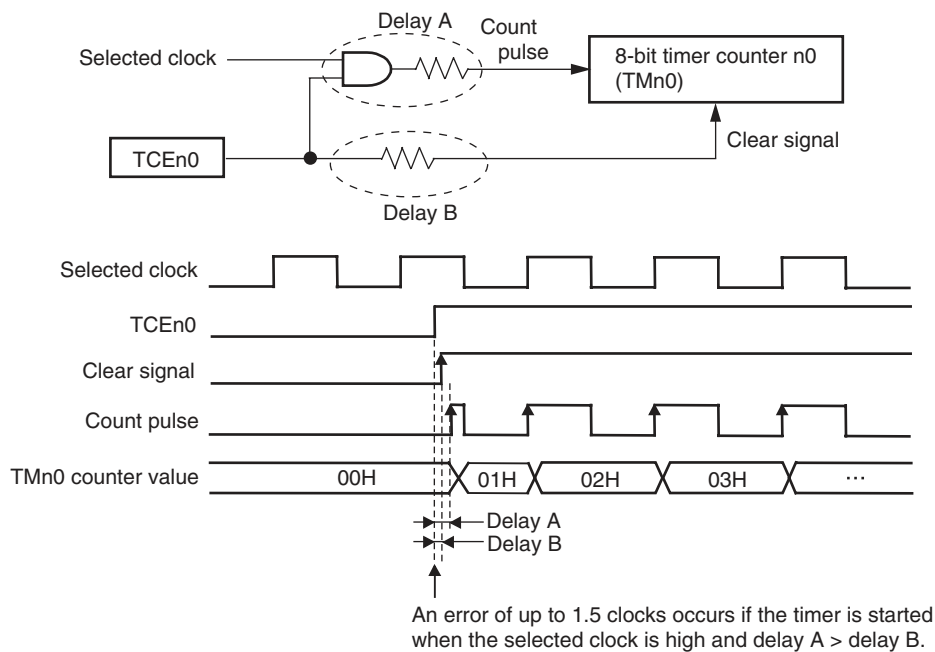

Remark n = 3, 4

(2) Count value if external clock input from TMI pin is selected

When the external clock signal input from the TMI pin is selected as the count clock, the count value may start from 01H if the timer is enabled (TCE40 = 0 → 1) while the TMI pin is high. This is because the input signal of the TMI pin is internally ANDed with the TCE40 signal. Consequently, the counter is incremented because the rising edge of the count clock is input to the timer immediately when the TCE40 pin is set. Depending on the delay timing, the count value is incremented by one if the rising edge is input after the counter is cleared. Counting is not affected if the rising edge is input before the counter is cleared (the counter operates normally).

Use the timer being aware that it has an error of one count, or take either of the following actions A or B.

<Action A> Always start the timer when the TMI pin is low.

<Action B> Save the count value to a control register when the timer is started, SUB the count value with the count value saved to the control register when reading the count value, and take the result of SUB as the true count value.

Figure 9-25. Counting Operation if Timer Is Started When TMI Is High

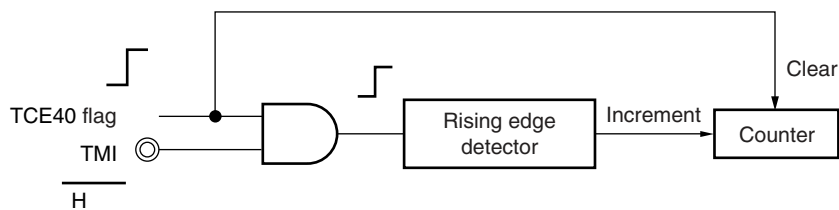

(3) Setting of 8-bit compare register n0

8-bit compare register n0 (CRn0) can be set to 00H.

Therefore, one pulse can be counted when the 8-bit timer operates as an event counter.

Figure 9-26. Timing of Operation as External Event Counter (8-Bit Resolution)

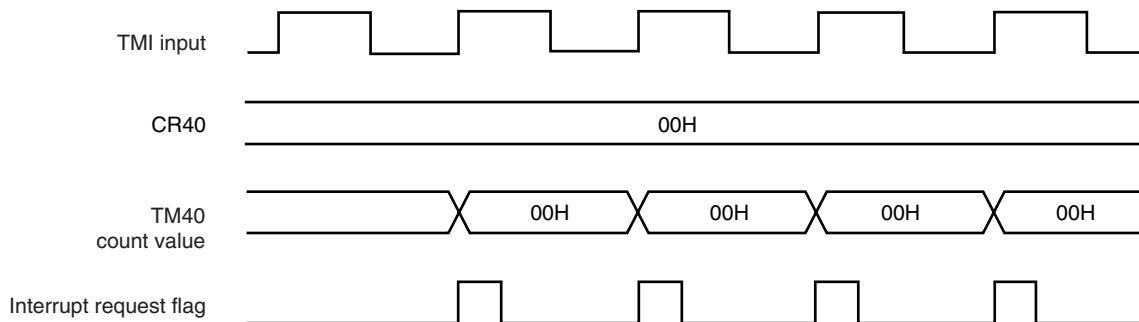

Remark n = 3, 4

CHAPTER 10 WATCHDOG TIMER

10.1 Watchdog Timer Functions

The watchdog timer has the following functions:

- Watchdog timer
- Interval timer

Caution Select the watchdog timer mode or interval timer mode by using the watchdog timer mode register (WDTM).

(1) Watchdog timer

The watchdog timer is used to detect inadvertent program loops. When the inadvertent program loop is detected, a non-maskable interrupt or a $\overline{\text{RESET}}$ signal can be generated.

Table 10-1. Inadvertent Program Loop Detection Time of Watchdog Timer

Inadvertent Program Loop Detection Time	At $f_x = 5.0 \text{ MHz}$	At $f_{cc} = 1.0 \text{ MHz}$
$2^{11} \times 1/f_{\text{CLK}}$	$2^{11}/f_x$ (410 μs)	$2^{11}/f_{cc}$ (2.05 ms)
$2^{13} \times 1/f_{\text{CLK}}$	$2^{13}/f_x$ (1.64 ms)	$2^{13}/f_{cc}$ (8.19 ms)
$2^{15} \times 1/f_{\text{CLK}}$	$2^{15}/f_x$ (6.55 ms)	$2^{15}/f_{cc}$ (32.8 ms)
$2^{17} \times 1/f_{\text{CLK}}$	$2^{17}/f_x$ (26.2 ms)	$2^{17}/f_{cc}$ (131.1 ms)

- Remarks**
1. f_{CLK} : f_x or f_{cc}
 2. f_x : System clock oscillation frequency (ceramic/crystal oscillation)
 3. f_{cc} : System clock oscillation frequency (RC oscillation)

(2) Interval timer

The interval timer generates an interrupt at an arbitrary preset interval.

Table 10-2. Interval Time of Watchdog Timer

Interval	At $f_x = 5.0 \text{ MHz}$	At $f_{cc} = 1.0 \text{ MHz}$
$2^{11} \times 1/f_{\text{CLK}}$	$2^{11}/f_x$ (410 μs)	$2^{11}/f_{cc}$ (2.05 ms)
$2^{13} \times 1/f_{\text{CLK}}$	$2^{13}/f_x$ (1.64 ms)	$2^{13}/f_{cc}$ (8.19 ms)
$2^{15} \times 1/f_{\text{CLK}}$	$2^{15}/f_x$ (6.55 ms)	$2^{15}/f_{cc}$ (32.8 ms)
$2^{17} \times 1/f_{\text{CLK}}$	$2^{17}/f_x$ (26.2 ms)	$2^{17}/f_{cc}$ (131.1 ms)

- Remarks**
1. f_{CLK} : f_x or f_{cc}
 2. f_x : System clock oscillation frequency (ceramic/crystal oscillation)
 3. f_{cc} : System clock oscillation frequency (RC oscillation)

10.2 Watchdog Timer Configuration

The watchdog timer includes the following hardware.

Table 10-3. Configuration of Watchdog Timer

Item	Configuration
Control registers	Timer clock selection register 2 (TCL2) Watchdog timer mode register (WDTM)

Figure 10-1. Block Diagram of Watchdog Timer

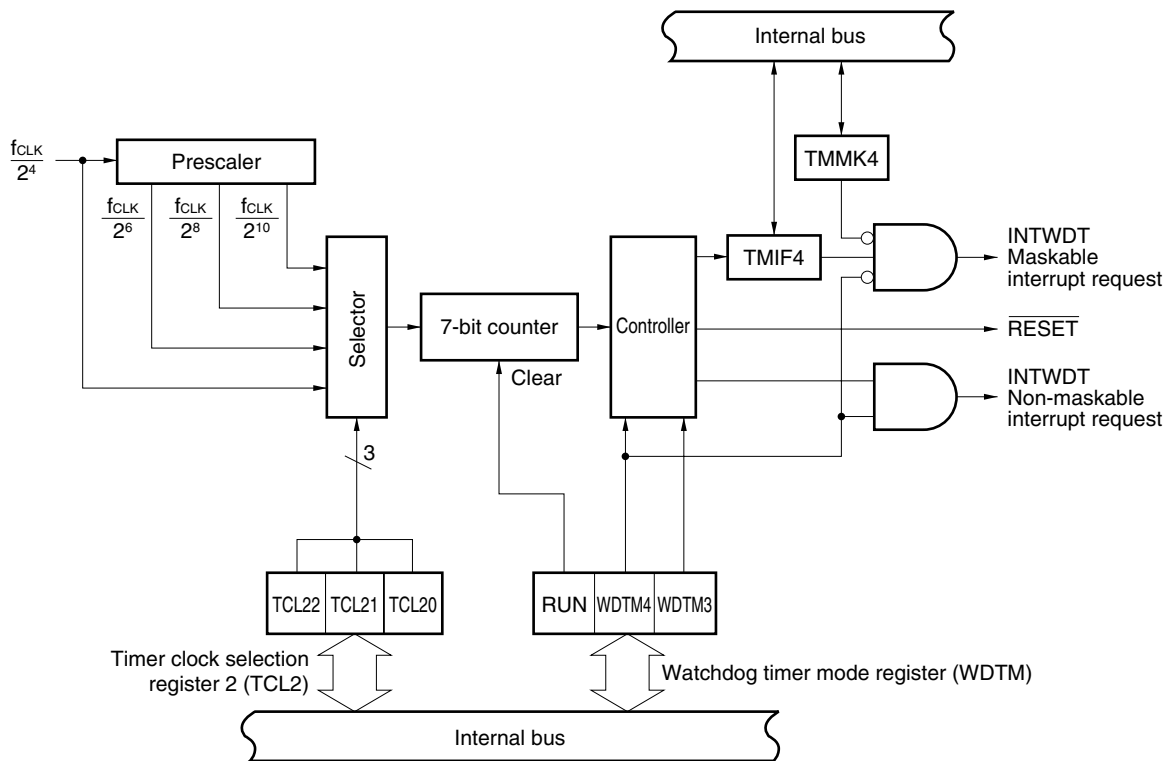

Remark f_{CLK} : f_x or f_{cc}

10.3 Watchdog Timer Control Registers

The following two registers are used to control the watchdog timer.

- Timer clock selection register 2 (TCL2)
- Watchdog timer mode register (WDTM)

(1) Timer clock selection register 2 (TCL2)

This register sets the watchdog timer count clock.

TCL2 is set with an 8-bit memory manipulation instruction.

$\overline{\text{RESET}}$ input clears TCL2 to 00H.

Figure 10-2. Format of Timer Clock Selection Register 2

Symbol	7	6	5	4	3	<2>	<1>	<0>	Address	After reset	R/W
TCL2	0	0	0	0	0	TCL22	TCL21	TCL20	FF42H	00H	R/W

TCL22	TCL21	TCL20	Count clock selection	
			At $f_x = 5.0 \text{ MHz}$	At $f_{cc} = 1.0 \text{ MHz}$
0	0	0	$f_x/2^4$ (313 kHz)	$f_{cc}/2^4$ (62.5 kHz)
0	1	0	$f_x/2^6$ (78.1 kHz)	$f_{cc}/2^6$ (15.6 kHz)
1	0	0	$f_x/2^8$ (19.5 kHz)	$f_{cc}/2^8$ (3.91 kHz)
1	1	0	$f_x/2^{10}$ (4.88 kHz)	$f_{cc}/2^{10}$ (977 Hz)
Other than above			Setting prohibited	

- Remarks**
1. f_x : System clock oscillation frequency (ceramic/crystal oscillation)
 2. f_{cc} : System clock oscillation frequency (RC oscillation)

(2) Watchdog timer mode register (WDTM)

This register sets the operation mode of the watchdog timer, and enables/disables counting of the watchdog timer.

WDTM is set with a 1-bit or 8-bit memory manipulation instruction.

$\overline{\text{RESET}}$ input clears WDTM to 00H.

Figure 10-3. Format of Watchdog Timer Mode Register

Symbol	<7>	6	5	4	3	2	1	0	Address	After reset	R/W
WDTM	RUN	0	0	WDTM4	WDTM3	0	0	0	FFF9H	00H	R/W

RUN	Watchdog timer operation selection ^{Note 1}
0	Stops counting.
1	Clears counter and starts counting.

WDTM4	WDTM3	Watchdog timer operation mode selection ^{Note 2}
0	0	Operation stop
0	1	Interval timer mode (Generates a maskable interrupt upon overflow occurrence.) ^{Note 3}
1	0	Watchdog timer mode 1 (Generates a non-maskable interrupt upon overflow occurrence.)
1	1	Watchdog timer mode 2 (Starts a reset operation upon overflow occurrence.)

- Notes**
- Once RUN has been set to 1, it cannot be cleared to 0 by software. Therefore, when counting is started, it cannot be stopped by any means other than $\overline{\text{RESET}}$ input.
 - Once WDTM3 and WDTM4 have been set to 1, they cannot be cleared to 0 by software.
 - The watchdog timer starts operation as an interval timer when RUN is set to 1.

- Cautions**
- When the watchdog timer is cleared by setting RUN to 1, the actual overflow time is up to 0.8% shorter than the time set by the timer clock selection register 2 (TCL2).
 - To set watchdog timer mode 1 or 2, set WDTM4 to 1 after confirming TMIF4 (bit 0 of interrupt request flag register 0 (IF0)) being set to 0. When watchdog timer mode 1 or 2 is selected with TMIF4 set to 1, a non-maskable interrupt is generated upon the completion of rewriting WDTM.

10.4 Watchdog Timer Operation

10.4.1 Operation as watchdog timer

The watchdog timer detects an inadvertent program loop when bit 4 (WDTM4) of the watchdog timer mode register (WDTM) is set to 1.

The count clock (inadvertent program loop detection time interval) of the watchdog timer can be selected by bits 0 to 2 (TCL20 to TCL22) of the timer clock selection register 2 (TCL2). By setting bit 7 (RUN) of WDTM to 1, the watchdog timer is started. Set RUN to 1 within the set inadvertent program loop detection time interval after the watchdog timer has been started. By setting RUN to 1, the watchdog timer can be cleared and start counting. If RUN is not set to 1, and the inadvertent program loop detection time is exceeded, a system reset signal or a non-maskable interrupt is generated, depending on the value of bit 3 (WDTM3) of WDTM.

The watchdog timer continues operation in HALT mode, but stops in STOP mode. Therefore, first set RUN to 1 to clear the watchdog timer before executing the STOP instruction.

Caution The actual inadvertent program loop detection time may be up to 0.8% shorter than the set time.

Table 10-4. Inadvertent Program Loop Detection Time of Watchdog Timer

TCL22	TCL21	TCL20	At $f_x = 5.0$ MHz	At $f_{cc} = 1.0$ MHz
0	0	0	$2^{11}/f_x$ (410 μ s)	$2^{11}/f_{cc}$ (2.05 ms)
0	1	0	$2^{13}/f_x$ (1.64 ms)	$2^{13}/f_{cc}$ (8.19 ms)
1	0	0	$2^{15}/f_x$ (6.55 ms)	$2^{15}/f_{cc}$ (32.8 ms)
1	1	0	$2^{17}/f_x$ (26.2 ms)	$2^{17}/f_{cc}$ (131.1 ms)
Other than above			Setting prohibited	

- Remarks**
1. f_x : System clock oscillation frequency (ceramic/crystal oscillation)
 2. f_{cc} : System clock oscillation frequency (RC oscillation)

10.4.2 Operation as interval timer

When bits 4 and 3 (WDTM4, WDTM3) of the watchdog timer mode register (WDTM) are set to 0 and 1, respectively, the watchdog timer operates as an interval timer that repeatedly generates an interrupt at an interval specified by a preset count value.

Select a count clock (or interval time) by setting bits 0 to 2 (TCL20 to TCL22) of the timer clock selection register 2 (TCL2). The watchdog timer starts operation as an interval timer when the RUN bit (bit 7 of WDTM) is set to 1.

In interval timer mode, the interrupt mask flag (TMMK4) is valid, and a maskable interrupt (INTWDT) can be generated. The priority of INTWDT is set as the highest of all the maskable interrupts.

The interval timer continues operation in HALT mode, but stops in STOP mode. Therefore, first set RUN to 1 to clear the interval timer before executing the STOP instruction.

- Cautions**
1. Once bit 4 (WDTM4) of WDTM is set to 1 (when watchdog timer mode is selected), interval timer mode is not set unless a $\overline{\text{RESET}}$ signal is input.
 2. The interval time may be up to 0.8% shorter than the set time when WDTM has just been set.

Table 10-5. Interval Time of Watchdog Timer

TCL22	TCL21	TCL20	At $f_x = 5.0 \text{ MHz}$	At $f_{cc} = 1.0 \text{ MHz}$
0	0	0	$2^{11}/f_x$ (410 μs)	$2^{11}/f_{cc}$ (2.05 ms)
0	1	0	$2^{13}/f_x$ (1.64 ms)	$2^{13}/f_{cc}$ (8.19 ms)
1	0	0	$2^{15}/f_x$ (6.55 ms)	$2^{15}/f_{cc}$ (32.8 ms)
1	1	0	$2^{17}/f_x$ (26.2 ms)	$2^{17}/f_{cc}$ (131.1 ms)
Other than above			Setting prohibited	

- Remarks**
1. f_x : System clock oscillation frequency (ceramic/crystal oscillation)
 2. f_{cc} : System clock oscillation frequency (RC oscillation)

CHAPTER 11 POWER-ON-CLEAR CIRCUITS (μ PD78E9860A, 78E9861A ONLY)

11.1 Power-on-Clear Circuit Functions

The power-on-clear circuits include the following two circuits, which have the following function.

(1) Power-on-clear (POC) circuit

- Compares the detection voltage (V_{POC}) with the power supply voltage (V_{DD}) and generates an internal reset signal if $V_{DD} < V_{POC}$.
- This circuit can operate even in STOP mode.

(2) Low-voltage detection (LVI) circuit

- Compares the detection voltage (V_{LVI}) with the power supply voltage (V_{DD}) and generates an interrupt request signal (INTLVI1) if $V_{DD} < V_{LVI}$.
- Eight levels of detection voltage can be selected using software.
- This circuit stops operation in STOP mode.

11.2 Power-on-Clear Circuit Configuration

Figures 11-1 and 11-2 show the block diagrams of the power-on-clear circuits.

Figure 11-1. Block Diagram of Power-on-Clear Circuit

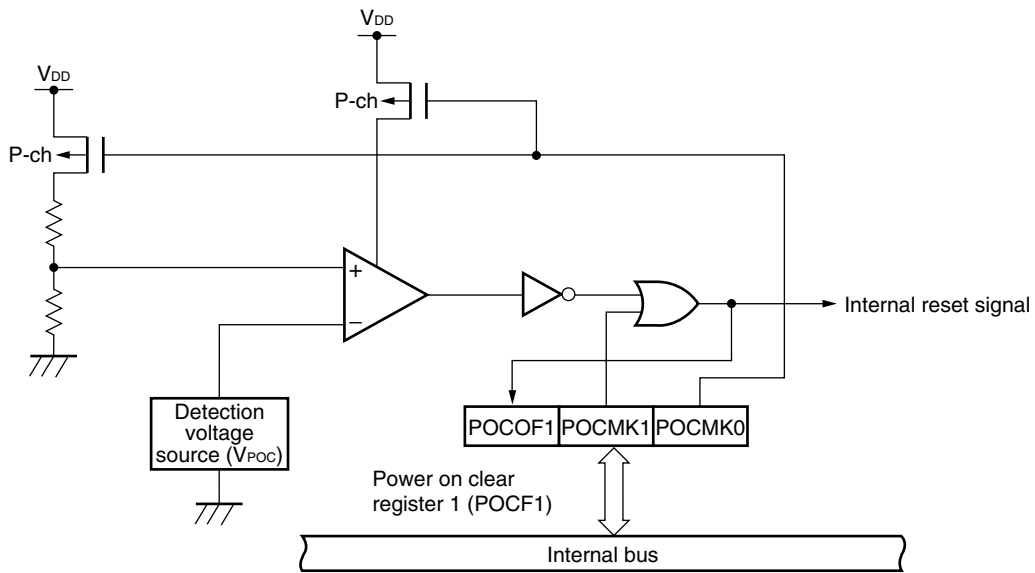
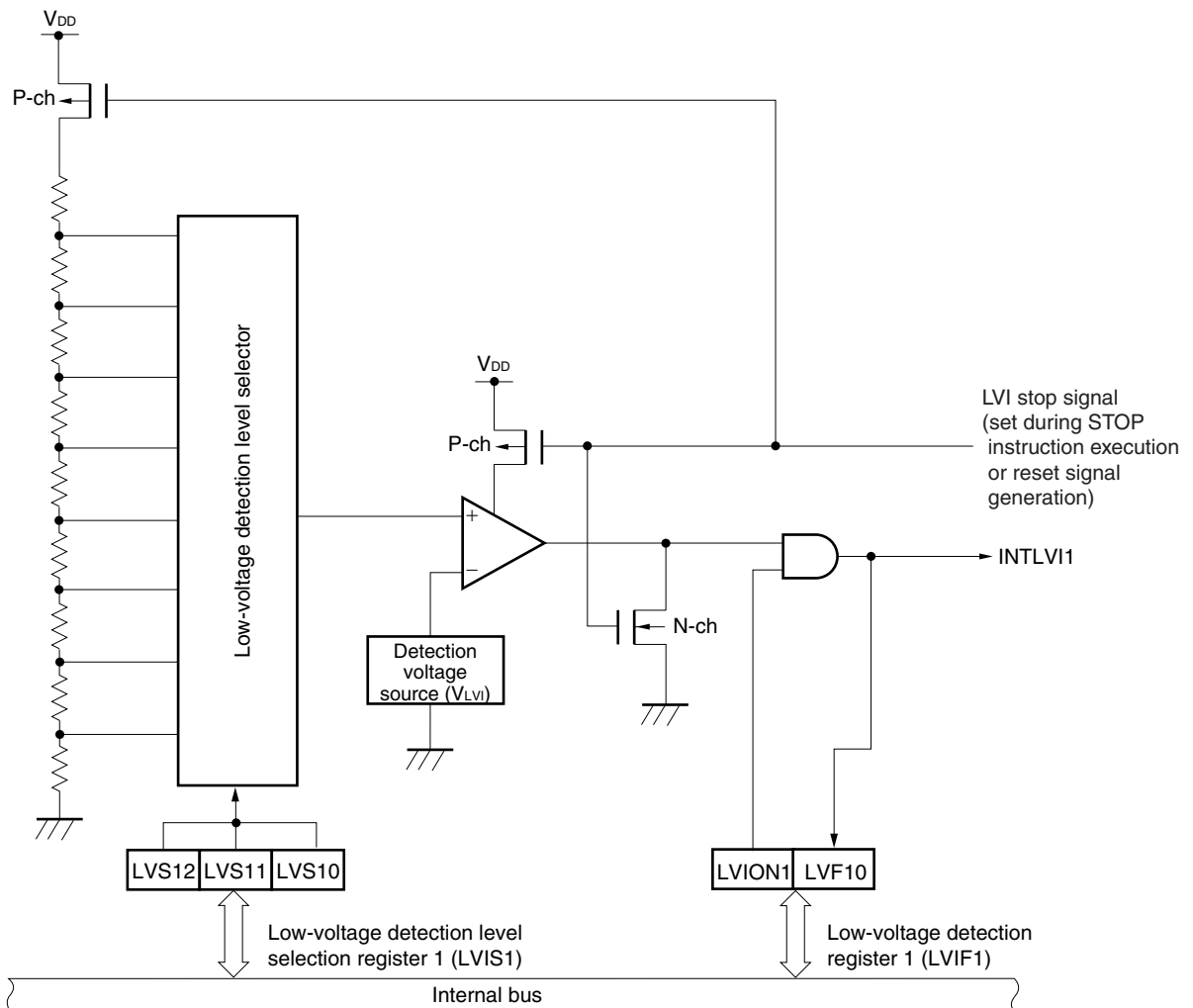

Figure 11-2. Block Diagram of Low-Voltage Detection Circuit



11.3 Power-on-Clear Circuit Control Registers

The following three registers control the power-on-clear circuits.

- Power-on-clear register 1 (POCF1)
- Low-voltage detection register 1 (LVIF1)
- Low-voltage detection level selection register 1 (LVIS1)

(1) Power-on-clear register 1 (POCF1)

This register controls POC circuit operation.

POCF1 is set with a 1-bit or 8-bit memory manipulation instruction.

Figure 11-3. Format of Power-on-Clear Register 1

Symbol	7	6	5	4	3	<2>	<1>	<0>	Address	After reset	R/W
POCF1	0	0	0	0	0	POCOF1	POCMK1	POCMK0	FFDDH	00H ^{Note}	R/W

POCOF1	POC output detection flag
0	Non-generation of reset signal by POC or in cleared state due to a write operation to POCF1
1	Generation of reset signal by POC

POCMK1	POC reset control
0	Generation of reset signal by POC enabled
1	Generation of reset signal by POC disabled

POCMK0	POC operation control
0	POC operating
1	POC halted

Note This value is 04H only after a power-on-clear reset.

(2) Low-voltage detection register 1 (LVIF1)

This register controls the operation of the LVI circuit.

LVIF1 is set with a 1-bit or 8-bit memory manipulation instruction.

$\overline{\text{RESET}}$ input sets this register to 00H.

Figure 11-4. Format of Low-Voltage Detection Register 1

Symbol	<7>	6	5	4	3	2	1	<0>	Address	After reset	R/W
LVIF1	LVION1	0	0	0	0	0	0	LVF10	FFDEH	00H	R/W ^{Note}

LVION1	LVI operation enable flag
0	LVI disabled
1	LVI enabled

LVF10	LVI output detection flag
0	Power supply voltage (V_{DD}) > LVI detection voltage (V_{LVI}) or operation disabled
1	$V_{DD} < V_{LVI}$

Note Bit 0 is read only.

(3) Low-voltage detection level selection register 1 (LVIS1)

This register selects the level of the detection voltage (V_{LVI}).

LVIS1 is set with a 1-bit or 8-bit memory manipulation instruction.

$\overline{\text{RESET}}$ input sets this register to 00H.

Figure 11-5. Format of Low-Voltage Detection Level Selection Register 1

Symbol	7	6	5	4	3	<2>	<1>	<0>	Address	After reset	R/W
LVIS1	0	0	0	0	0	LVS12	LVS11	LVS10	FFDFH	00H	R/W

LVS12	LVS11	LVS10	Selection of detection voltage (V_{LVI}) level ^{Note}
0	0	0	V_{LVI0}
0	0	1	V_{LVI1}
0	1	0	V_{LVI2}
0	1	1	V_{LVI3}
1	0	0	V_{LVI4}
1	0	1	V_{LVI5}
1	1	0	V_{LVI6}
1	1	1	V_{LVI7}

Note Refer to **CHAPTER 20 ELECTRICAL SPECIFICATIONS** for detection voltage specifications.

Caution When changing the detection voltage level (V_{LVI}), an operation stabilization time of about 2 ms is required in order for the LVI output to stabilize. Do not, therefore, set the LVI circuit to operation-enable until the operation has stabilized.

11.4 Power-on-Clear Circuit Operation

11.4.1 Power-on-clear (POC) circuit operation

The POC circuit compares the detection voltage (V_{POC}) with the power supply voltage (V_{DD}) and generates an internal reset signal if $V_{DD} < V_{POC}$.

For the μ PD78E9860A and 78E9861A, POC operation can be controlled by the POC switching circuit.

Observe the following procedure when switching POC operation.

(1) Switching from POC stopped to POC operating

- <1> Check that $POCMK1 = 1$
- <2> Set $POCMK0$ to 0 to put the POC circuit into the operating state
- <3> Wait until the operation stabilization time has elapsed (because the output signal is unstable, generation of the reset signal via the POC circuit is set to disabled)
- <4> Set $POCMK1$ to 0 to enable generation of the reset signal via the POC circuit

(2) Switching from POC operating to POC stopped

- <1> Set $POCMK1$ to 1 to disable generation of the reset signal via the POC circuit
- <2> Set $POCMK0$ to 1 to put the POC circuit into the operation stopped state

Generation of the reset signal via the POC circuit can be determined by reading the $POCOF1$ flag. When the reset signal is generated via the POC circuit, $POCOF1$ is set to 1. $POCOF1$ is cleared by writing 0 to $POCF1$ ^{Note}.

When using the POC circuit, clear the $POCOF1$ beforehand.

Note $POCOF1$ is cleared when data is written to any of bits 0 to 2 in the $POCF1$ register.

Figure 11-6 shows the timing of reset signal generation via the POC circuit.

Figure 11-6. Timing of Internal Reset Signal Generation in POC Switching Circuit

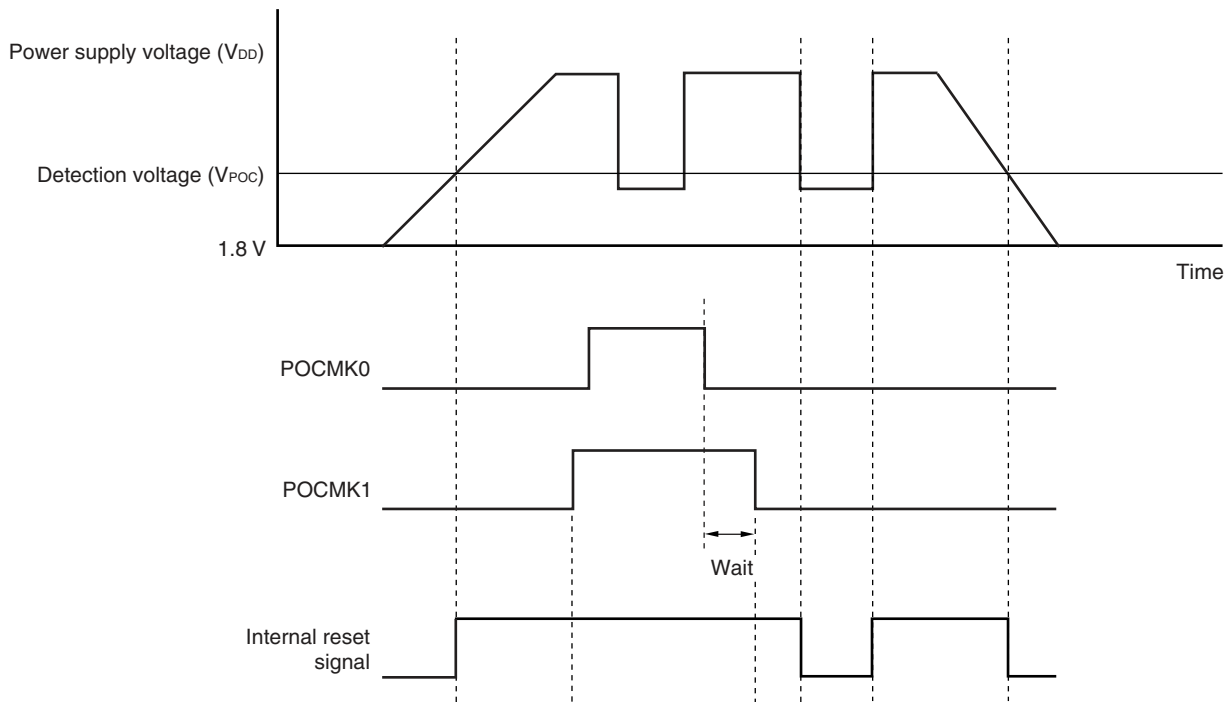

11.4.2 Operation of low-voltage detection (LVI) circuit

The LVI circuit compares the detection voltage (V_{LVI}) with the power supply voltage (V_{DD}) and generates an interrupt request signal (INTLVI1) if $V_{DD} < V_{LVI}$ (LVI circuit operating).

As shown in **Figure 11-2 Block Diagram of Low-Voltage Detection Circuit**, the divided resistors and comparators of the LVI circuit turn OFF when the reset signal is generated or in STOP mode. After reset is released, LVI operation starts when LVION1 (bit 7 of low-voltage detection register 1 (LVIF1)) is set. At this time, approximately 2 ms are required until the LVI circuit operation is stabilized.

Once the LVI operation is started, divided resistors and comparators cannot be OFF unless the STOP instruction or reset signal is generated, even LVION1 is cleared. Low-voltage detection is enabled immediately after LVION1 is set again.

Caution The divider resistor and comparator of the LVI circuit are turned ON after reset is released.

Use one of the following methods to constantly monitor low voltage.

- <1> Low-voltage monitoring by LVFI0 (bit 0 of low-voltage detection register 1 (LVIF1)) without using LVI detection interrupt.
- <2> Low-voltage monitoring using LVI detection interrupt. In this case, disable the LVI operation once, and then enable it (LVION1 = 0 \rightarrow 1) before enabling interrupts (LVIMK1 = 0).

An example of a program in which low voltage is constantly monitored using the LVI detection interrupt is shown below.

(a) Processing when reset mode is released

```

DI
MOV    LVIS1, #xxH;    Setting LVI detection voltage
SET1   LVIMK1;        LVI interrupt disabled
SET1   LVION1;        LVI operation enabled
CALL   !WAIT_2ms;     2 ms wait
CLR1   LVIF1;
CLR1   LVION1;        LVI operation disabled
SET1   LVION1;        LVI operation enabled
CLR1   LVIMK1;        LVI interrupt enabled
EI

```

(b) Processing when STOP mode is released

```

SET1   LVIMK1;        LVI interrupt disabled
STOP
CALL   !WAIT;         Total 2 ms wait, combined with oscillation stabilization time
CLR1   LVIF1
CLR1   LVION1;        LVI operation disabled
SET1   LVION1;        LVI operation enabled
CLR1   LVIMK1;        LVI interrupt enabled
EI

```

(c) Processing to enable LVI interrupt again after LVI interrupt servicing

SET1	LVIMK1;	LVI interrupt disabled
CLR1	LVION1;	LVI operation disabled
SET1	LVION1;	LVI operation enabled
CLR1	LVIMK1;	LVI interrupt enabled
EI		

Figure 11-7 shows the LVI circuit operation timing.

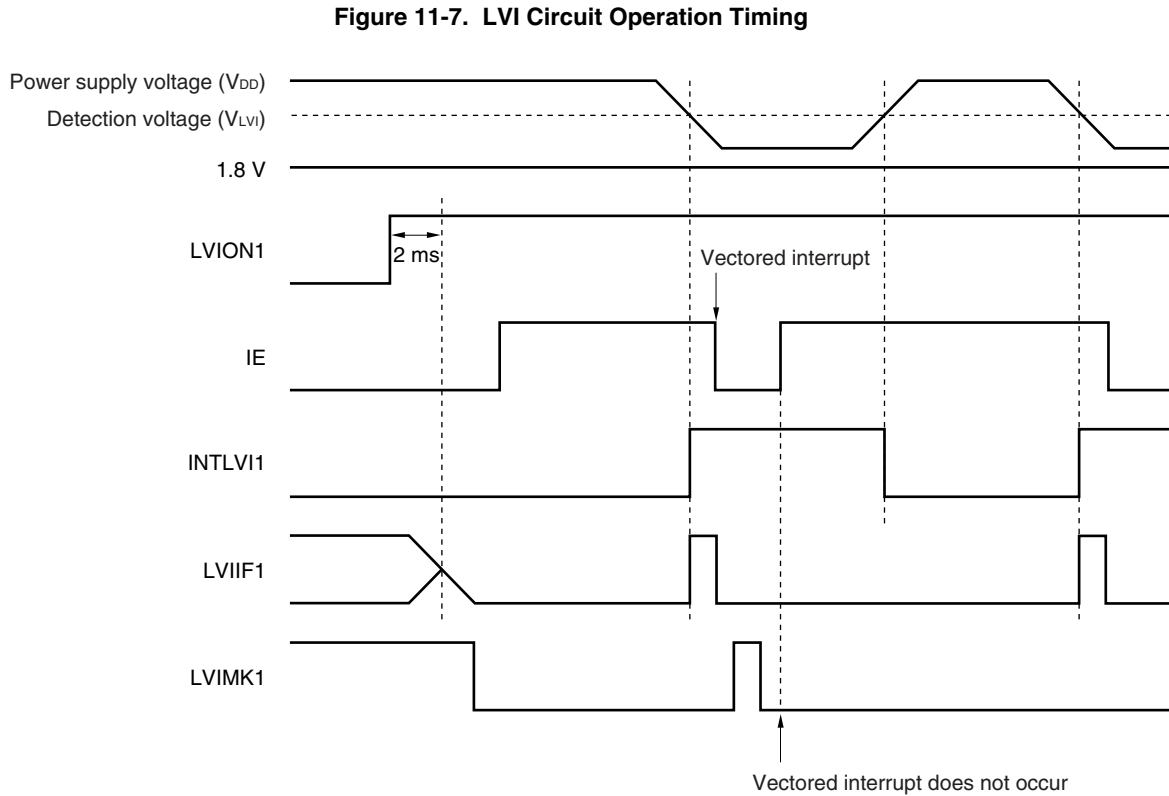

Caution The low-voltage detection interrupt request flag (LVIIIF1) is set at the rising edge of the LVI circuit comparator output signal (INTLVI1). Therefore, the power supply voltage (V_{DD}) becomes lower than the detection voltage (V_{LVI}) during LVI operation, and if that state continues after INTLVI1 generation, LVIIIF1 is not set. After low-voltage detection, when set as $V_{DD} > V_{LVI}$ and then $V_{DD} < V_{LVI}$ again, LVIIIF1 is set.

CHAPTER 12 BIT SEQUENTIAL BUFFER

12.1 Bit Sequential Buffer Functions

The μ PD789052, 789062 Subseries have an on-chip bit sequential buffer of 8 bits + 8 bits = 16 bits. The functions of the bit sequential buffer are shown below.

- If the value of the bit sequential buffer 10 data register (BSFRL10, BSFRH10) is shifted 1 bit to the lower side, the LSB can be output to the port at the same time.
- It is possible to write to BSFRL10 and BSFRH10 using an 8-bit or 16-bit memory manipulation instruction (reading is not possible).
- Overwriting is enabled during a shift operation on the higher 8 bits (BSFRH10) only (the period in which shift clock is low level).

12.2 Bit Sequential Buffer Configuration

The bit sequential buffer includes the following hardware.

Table 12-1. Configuration of Bit Sequential Buffer

Item	Configuration
Data register	Bit sequential buffer: 8 bits + 8 bits = 16 bits
Control register	Bit sequential buffer output control register 10 (BSFC10) Port mode register 2 (PM2) Port 2 (P2)

Figure 12-1. Block Diagram of Bit Sequential Buffer

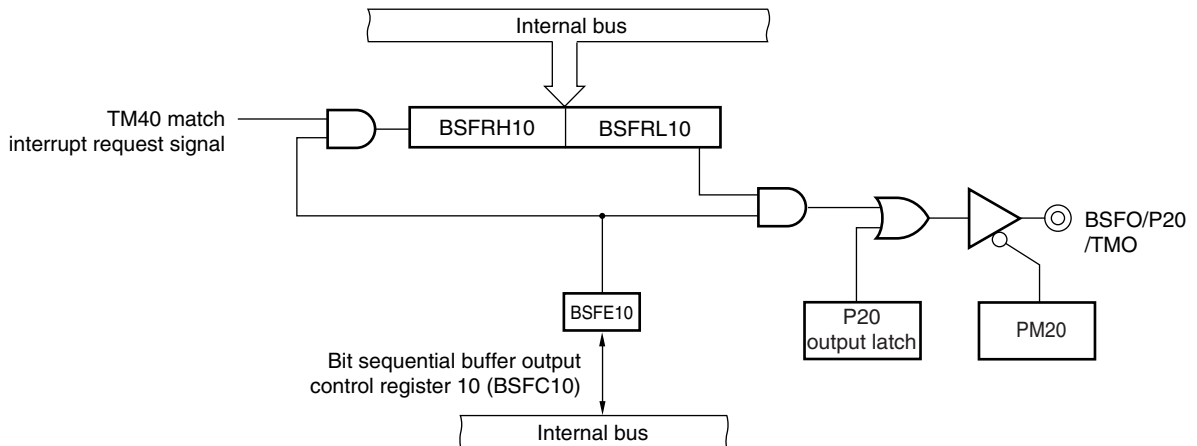

12.3 Bit Sequential Buffer Control Register

The bit sequential buffer is controlled by the following three registers.

- Bit sequential buffer output control register 10 (BSFC10)
- Port mode register 2 (PM2)
- Port 2 (P2)

(1) Bit sequential buffer output control register 10 (BSFC10)

This register controls the operation of the bit sequential buffer.

BSFC10 is set with a 1-bit or 8-bit memory manipulation instruction.

$\overline{\text{RESET}}$ input sets this register to 00H.

Figure 12-2. Format of Bit Sequential Buffer Output Control Register 10

Symbol	7	6	5	4	3	2	1	<0>	Address	After reset	R/W
BSFC10	0	0	0	0	0	0	0	BSFE10	FF60H	00H	R/W

BSFE10	Bit sequential buffer operation control
0	Operation disabled
1	Operation enabled

(2) Port mode register 2 (PM2)

PM2 sets port 2 to input/output in 1-bit units.

When using the P20/TMO/BSFO pin as a data output of the bit sequential buffer, clear the PM20 and P20 output latch to 0.

This register is set with a 1-bit or 8-bit memory manipulation instruction.

$\overline{\text{RESET}}$ input sets this register to FFH.

Figure 12-3. Format of Port Mode Register 2

Symbol	7	6	5	4	3	2	1	0	Address	After reset	R/W
PM2	1	1	1	1	1	1	PM21	PM20	FF22H	FFH	R/W

PM20	P20 pin input/output mode
0	Output mode (output buffer on)
1	Input mode (output buffer off)

12.4 Bit Sequential Buffer Operation

Set as follows to operate the bit sequential buffer.

- <1> Set values to bit sequential buffer 10 data registers L and H (BSFRL10, BSFRH10)
- <2> Set the bit sequential buffer to operation enabled (BSFE10 = 1)
If the LSB of BSFRL10 is being output at the P20/BSFO/TMO pin, set P20 to output mode (PM20 = 0) and the output latch of P20 to 0
- <3> Start the clock operation

If the clock is input before the bit sequential buffer starts operation, the output time of the start bit may be shorter than one cycle of the clock when output commences, as shown in the figure below.

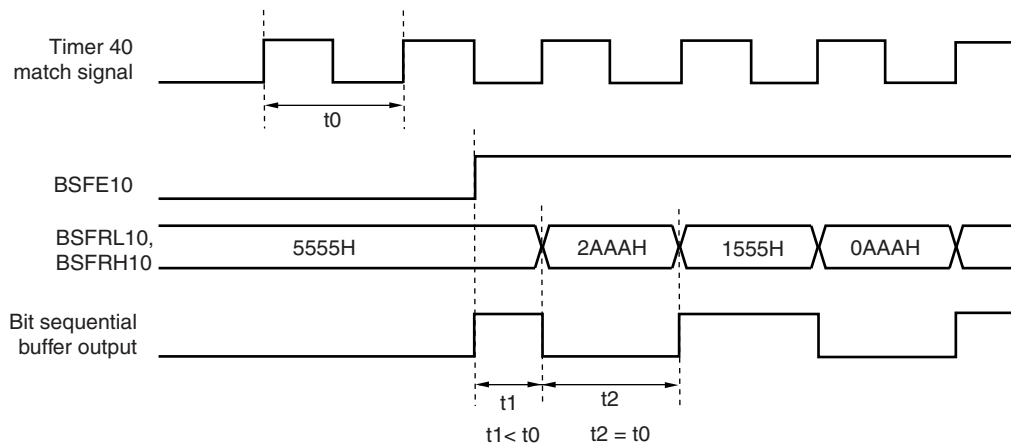
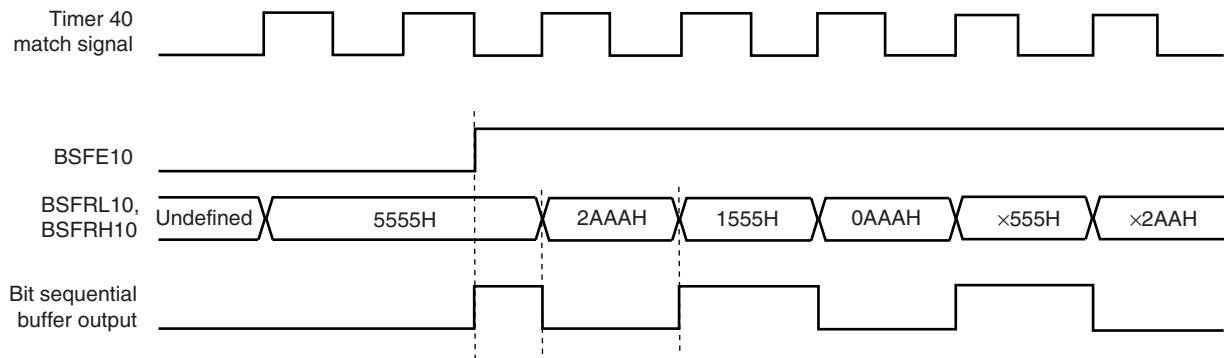

Figure 12-4 shows the operation timing of the bit sequential buffer.

Figure 12-4. Operation Timing of Bit Sequential Buffer



- Cautions**
1. Even if data is written to the data register while the bit sequential buffer is operating, the shift clock (timer 40 match signal) will not stop. Data should therefore be written to the data register when the shift clock is low level.
 2. The value of the data register is undefined after a shift.

Remark x: Undefined

CHAPTER 13 KEY RETURN CIRCUIT

13.1 Key Return Circuit Function

In STOP mode, this circuit generates a key return interrupt (INTKR1) by inputting a P40/KR10 to P43/KR13 falling edge.

- Cautions**
1. The key return interrupt is a non-maskable interrupt that is effective only in STOP mode. In addition, P40/KR10 to P43/KR13 key input cannot be performed by mask control.
 2. A key return signal cannot be detected while any one of the key return pins (P40/KR10 to P43/KR13) is low level even when a falling edge occurred at another pin.

13.2 Key Return Circuit Configuration and Operation

Figure 13-1 shows the block diagram of the key return circuit. Figure 13-2 shows the generation timing of the key return interrupt (INTKR1).

Figure 13-1. Block Diagram of Key Return Circuit

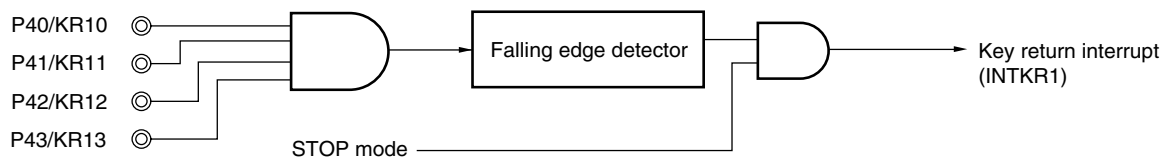
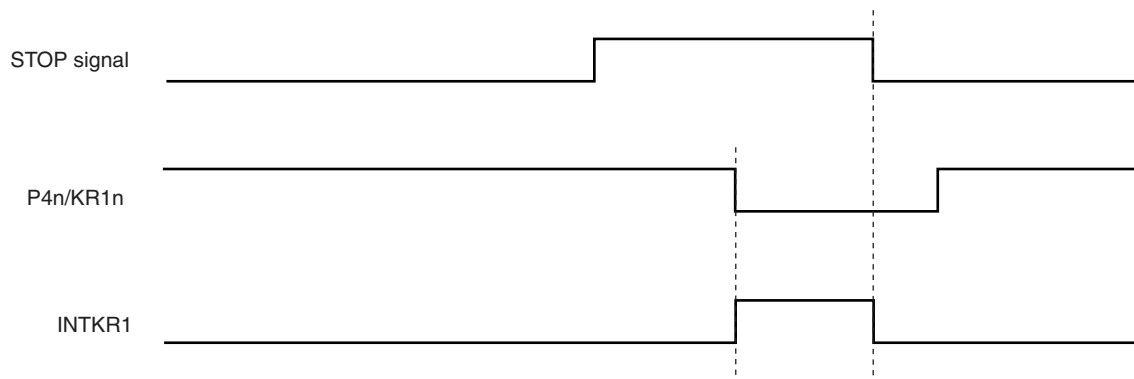

Figure 13-2. Generation Timing of Key Return Interrupt



Remark n = 0 to 3

CHAPTER 14 INTERRUPT FUNCTIONS

14.1 Interrupt Function Types

The following two types of interrupt functions are used.

(1) Non-maskable interrupts

This interrupt is acknowledged unconditionally even if interrupts are disabled. It does not undergo interrupt priority control and is given top priority over all other interrupt requests.

A standby release signal is generated.

There are one external source and one internal source of non-maskable interrupts.

(2) Maskable interrupts

These interrupts undergo mask control. If two or more interrupt requests are simultaneously generated, each interrupt has a predetermined priority as shown in Table 14-1.

A standby release signal is generated.

The number of maskable interrupt sources differs depending on the product as follows.

- μ PD789052, 789062: 3 internal sources
- μ PD78E9860A, 78E9861A: 5 internal sources

14.2 Interrupt Sources and Configuration

There are a total of 5 non-maskable and maskable interrupt sources in the μ PD789052 and 789062, and a total of 7 in the μ PD78E9860A and 78E9861A (see **Table 14-1**).

Table 14-1. Interrupt Sources

Interrupt Type	Priority ^{Note 1}	Interrupt Source		Internal/External	Vector Table Address	Basic Configuration Type ^{Note 2}
		Name	Trigger			
Non-maskable interrupt	–	INTKR1	Key return input falling edge detection	External	0002H	(A)
		INTWDT	Watchdog timer overflow (when watchdog timer mode 1 is selected)	Internal	0004H	
Maskable interrupt	0	INTWDT	Watchdog timer overflow (when interval timer mode is selected)	Internal		(B)
	1	INTTM30	Generation of match signal for 8-bit timer 30		0006H	
	2	INTTM40	Generation of match signal for 8-bit timer 40		0008H	
	3	INTLVI1 ^{Note 3}	LVI interrupt request signal		000AH	
	4	INTEE0 ^{Note 3}	EEPROM write termination signal		000CH	

- Notes**
1. Priority is the priority order when several maskable interrupt requests are generated at the same time. 0 is the highest and 4 is the lowest.
 2. Basic configuration types (A) and (B) correspond to (A) and (B) in Figure 14-1.
 3. μ PD78E9860A, 78E9861A only

Remark There are two interrupt sources for the watchdog timer (INTWDT): non-maskable interrupts and maskable interrupts (internal). Either one (but not both) should be selected for actual use.

Figure 14-1. Basic Configuration of Interrupt Function

(A) External/internal non-maskable interrupt

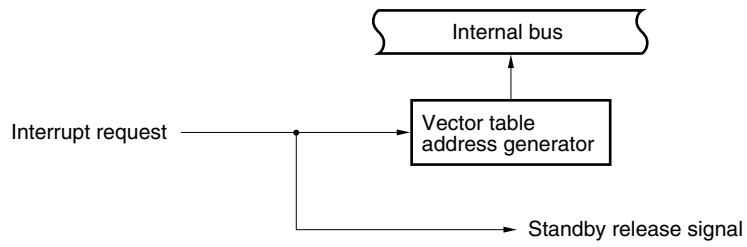

(B) Internal maskable interrupt

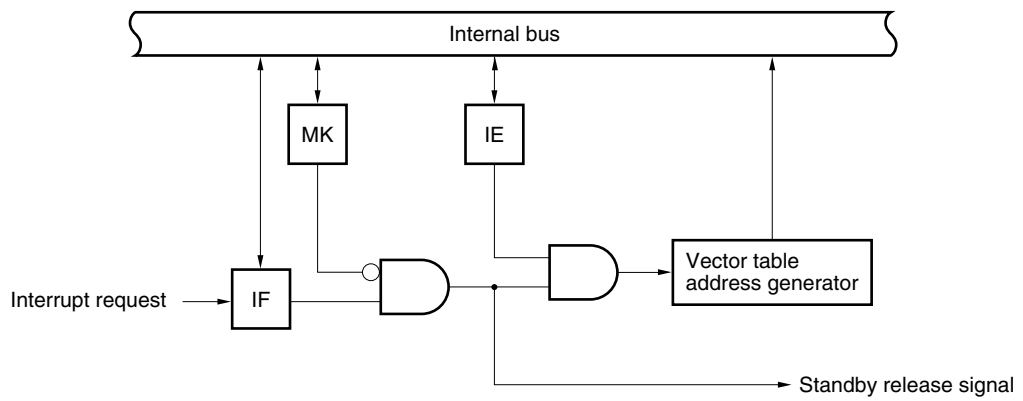

IF: Interrupt request flag

IE: Interrupt enable flag

MK: Interrupt mask flag

14.3 Interrupt Function Control Registers

The interrupt functions are controlled by the following three types of registers.

- Interrupt request flag register 0 (IF0)
- Interrupt mask flag register 0 (MK0)
- Program status word (PSW)

Table 14-2 lists interrupt requests, the corresponding interrupt request flags, and interrupt mask flags.

Table 14-2. Interrupt Request Signals and Corresponding Flags

Interrupt Request Signal	Interrupt Request Flag	Interrupt Mask Flag
INTWDT	TMIF4	TMMK4
INTTM30	TMIF30	TMMK30
INTTM40	TMIF40	TMMK40
INTLVI1 ^{Note}	LVIF1 ^{Note}	LVIMK1 ^{Note}
INTEE0 ^{Note}	EEIF0 ^{Note}	EEMK0 ^{Note}

Note μ PD78E9860A, 78E9861A only

(1) Interrupt request flag register 0 (IF0)

An interrupt request flag is set to 1 when the corresponding interrupt request is issued, or when the instruction is executed. It is cleared to 0 by executing an instruction when the interrupt request is acknowledged or when a $\overline{\text{RESET}}$ signal is input.

IF0 is set with a 1-bit or 8-bit memory manipulation instruction.

$\overline{\text{RESET}}$ input clears IF0 to 00H.

Figure 14-2. Format of Interrupt Request Flag Register 0

Symbol	7	6	5	<4>	<3>	<2>	<1>	<0>	Address	After reset	R/W
IF0	0	0	0	EEIF0 ^{Note}	LVIIIF1 ^{Note}	TMIF40	TMIF30	TMIF4	FFE0H	00H	R/W

xxIFx	Interrupt request flag
0	No interrupt request signal has been issued.
1	An interrupt request signal has been issued; an interrupt request status.

Note $\mu\text{PD78E9860A}$, 78E9861A only

Cautions 1. **Bits 5 to 7 must all be set to 0.**

2. **The TMIF4 flag can be read- and write-accessed only when the watchdog timer is being used as an interval timer. It must be cleared to 0 if the watchdog timer is used in watchdog timer mode 1 or 2.**

3. **When an interrupt is acknowledged, the interrupt request flag is automatically cleared and then the interrupt routine is started.**

(2) Interrupt mask flag register 0 (MK0)

The interrupt mask flag is used to enable and disable the corresponding maskable interrupts.

MK0 is set with a 1-bit or 8-bit memory manipulation instruction.

$\overline{\text{RESET}}$ input sets MK0 to FFH.

Figure 14-3. Format of Interrupt Mask Flag Register 0

Symbol	7	6	5	<4>	<3>	<2>	<1>	<0>	Address	After reset	R/W
MK0	0	0	0	EEMK0 ^{Note}	LVIMK1 ^{Note}	TMMK40	TMMK30	TMMK4	FFE4H	FFH	R/W

xxMKx	Interrupt servicing control
0	Enables servicing servicing.
1	Disables servicing servicing.

Note $\mu\text{PD78E9860A}$, 78E9861A only

Cautions 1. **Bits 5 to 7 must all be set to 1.**

★

2. **The TMMK4 flag can be read- and write-accessed only when the watchdog timer is being used as an interval timer.**

(3) Program status word (PSW)

The program status word is used to hold the instruction execution result and the current status of the interrupt requests. The IE flag, used to enable and disable maskable interrupts, is mapped to PSW.

PSW can be read- and write-accessed in 8-bit units, as well as using bit manipulation instructions and dedicated instructions (EI and DI). When a vectored interrupt is acknowledged, the PSW is automatically saved to a stack, and the IE flag is reset to 0.

RESET input sets PSW to 02H.

Figure 14-4. Program Status Word Configuration

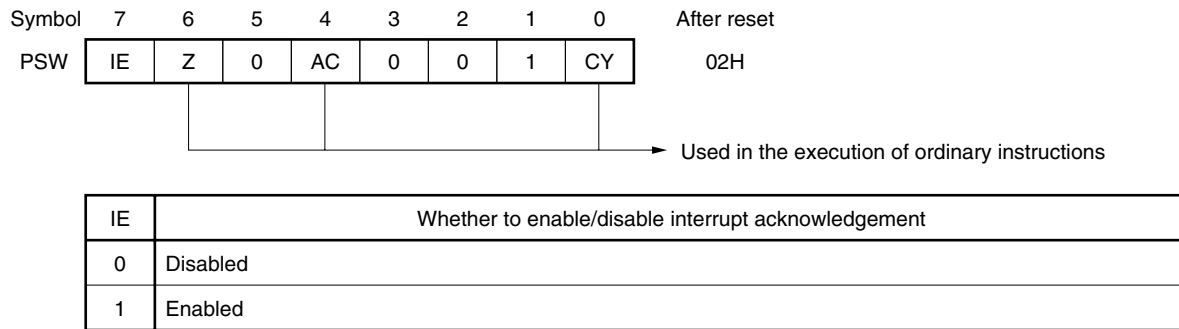

14.4 Interrupt Servicing Operation

14.4.1 Non-maskable interrupt request acknowledgement operation

The non-maskable interrupt request is unconditionally acknowledged even when interrupts are disabled. It is not subject to interrupt priority control and takes precedence over all other interrupts.

When the non-maskable interrupt request is acknowledged, PSW and PC are saved to the stack in that order, the IE flag is reset to 0, the contents of the vector table are loaded to the PC, and then program execution branches.

Figure 14-5 shows the flowchart from non-maskable interrupt request generation to acknowledgement. Figure 14-6 shows the timing of non-maskable interrupt request acknowledgement. Figure 14-7 shows the acknowledgement operation if multiple non-maskable interrupts are generated.

Caution The μ PD789052 and 789062 Subseries have two non-maskable interrupt sources. Therefore, during execution of a non-maskable interrupt servicing program, a new non-maskable interrupt request is not acknowledged until the RETI instruction is executed. Be sure to execute the RETI instruction after the interrupt servicing program has been executed.

When using the watchdog timer as a non-maskable interrupt, push the address of restore destination before executing the RETI instruction. If the RETI instruction is executed without pushing the restore destination, the program will jump to an illegal address. A program example is shown below.

<Example> Program example in which watchdog timer is used as non-maskable interrupt and program branches to reset vector when interrupt occurs

```

XVECT          CSEG  AT 0000H
DW  IRESET          ;(00)  RESET
DW  IKR              ;(02)  KeyReturn
DW  IWDT             ;(04)  INTWDT
:
XRST           CSEG  AT 0080H
IRESET: DI
            MOVW  AX,#0FEFFH
            MOVW  SP,AX
:
:
IWDT:
            (Interrupt servicing)
            MOVW  AX,#0080H
            PUSH  AX
            RETI

```

Figure 14-5. Flowchart from Non-Maskable Interrupt Request Generation to Acknowledgement (INTWDT)

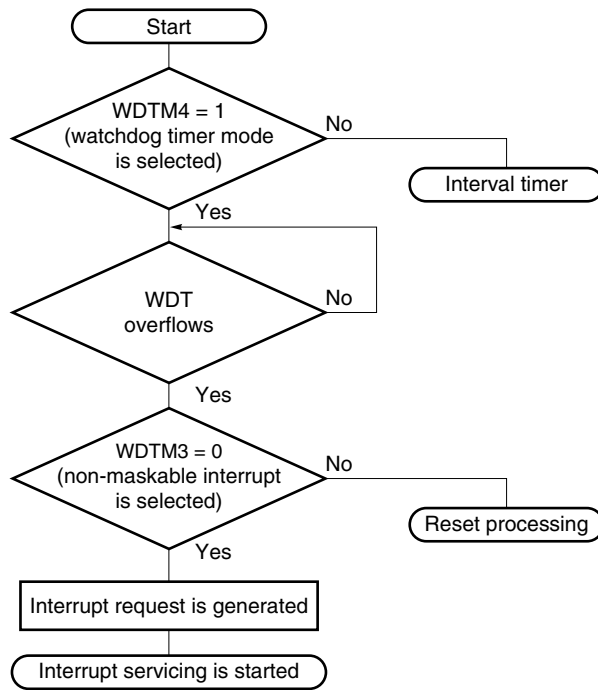

WDTM: Watchdog timer mode register
WDT: Watchdog timer

★

Figure 14-6. Timing of Non-Maskable Interrupt Request Acknowledgement

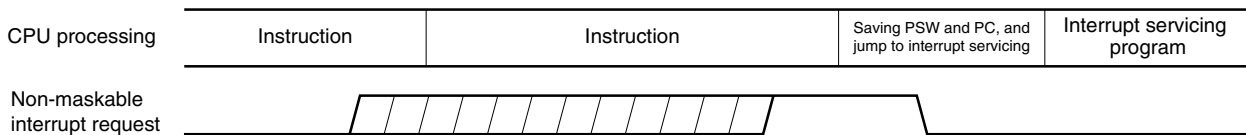
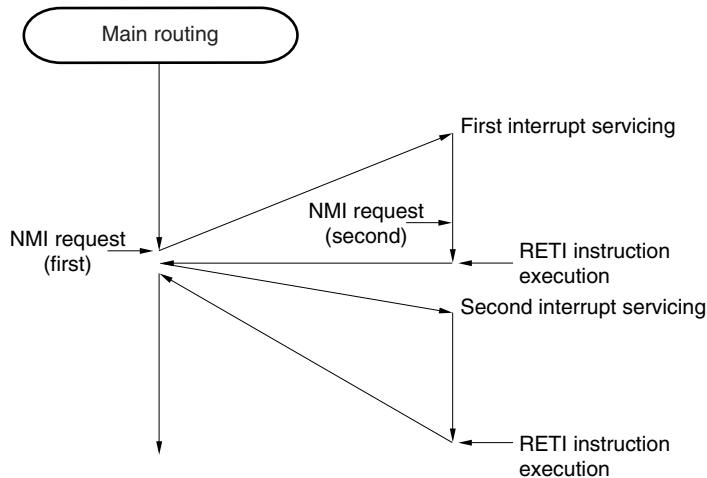

Figure 14-7. Acknowledgement of Non-Maskable Interrupt Request



14.4.2 Maskable interrupt request acknowledgement operation

A maskable interrupt request can be acknowledged when the interrupt request flag is set to 1 and the corresponding interrupt mask flag is cleared to 0. A vectored interrupt request is acknowledged in the interrupt enabled status (when the IE flag is set to 1).

The time required to start the interrupt servicing after a maskable interrupt request has been generated is shown in Table 14-3.

See **Figures 14-9** and **14-10** for the interrupt request acknowledgement timing.

Table 14-3. Time from Generation of Maskable Interrupt Request to Servicing

Minimum Time	Maximum Time ^{Note}
9 clocks	19 clocks

Note The wait time is maximum when an interrupt request is generated immediately before BT and BF instruction.

Remark 1 clock: $\frac{1}{f_{\text{CPU}}}$ (f_{CPU} : CPU clock)

When two or more maskable interrupt requests are generated at the same time, they are acknowledged starting from the interrupt request assigned the highest priority.

A pending interrupt is acknowledged when a status in which it can be acknowledged is set.

Figure 14-8 shows the algorithm of interrupt request acknowledgement.

When a maskable interrupt request is acknowledged, the contents of the PSW and PC are saved to the stack in that order, the IE flag is reset to 0, and the data in the vector table determined for each interrupt request is loaded to the PC, and execution branches.

To return from interrupt servicing, use the RETI instruction.

Figure 14-8. Interrupt Request Acknowledgement Processing Algorithm

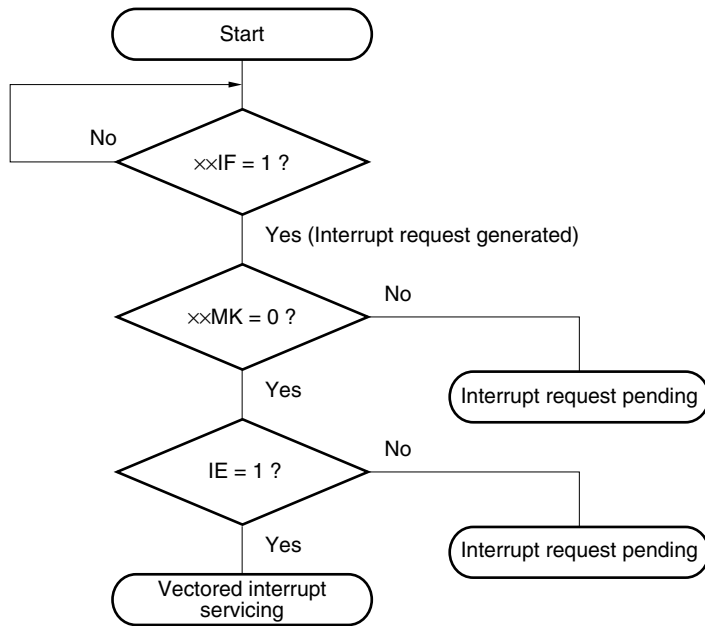

xxIF: Interrupt request flag

xxMK: Interrupt mask flag

IE: Flag to control maskable interrupt request acknowledgement (1 = enable, 0 = disable)

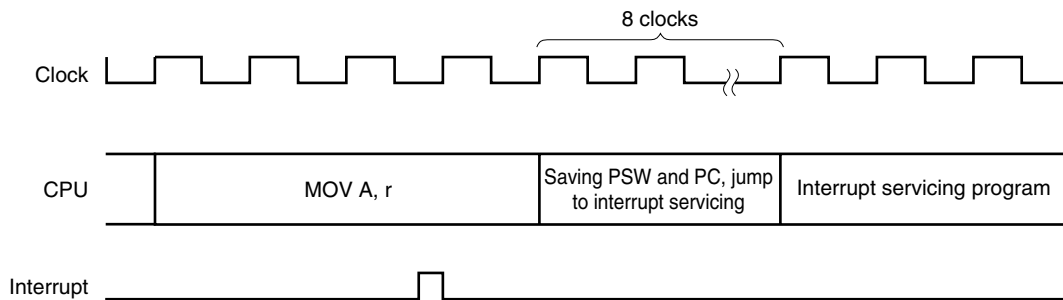
Figure 14-9. Interrupt Request Acknowledgement Timing (Example of MOV A, r)

If an interrupt request flag ($\times\times IF$) is set before an instruction clock n ($n = 4$ to 10) under execution becomes $n - 1$, the interrupt is acknowledged after the instruction under execution is complete. Figure 14-9 shows an example of the interrupt request acknowledgement timing for an 8-bit data transfer instruction `MOV A, r`. Since this instruction is executed for 4 clocks, if an interrupt occurs for 3 clocks after the execution starts, the interrupt acknowledgement processing is performed after the `MOV A, r` instruction is executed.

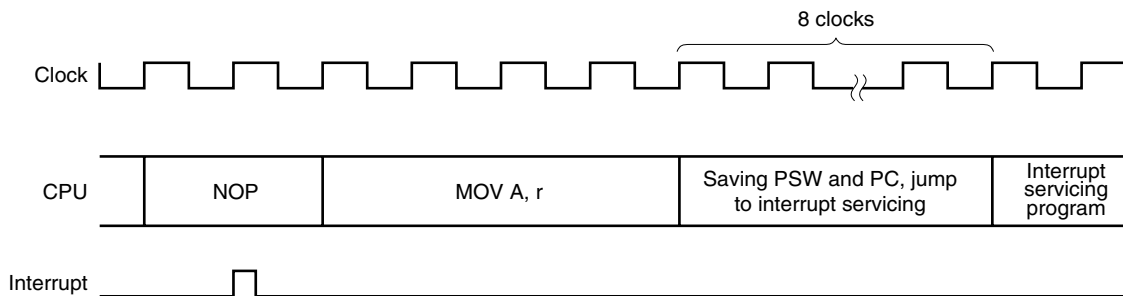
Figure 14-10. Interrupt Request Acknowledgement Timing (When Interrupt Request Flag Is Set at Last Clock During Instruction Execution)

If an interrupt request flag ($\times\times IF$) is set at the last clock of the instruction, the interrupt acknowledgement processing starts after the next instruction is executed.

Figure 14-10 shows an example of the interrupt acknowledgement timing for an interrupt request flag that is set at the second clock of `NOP` (2-clock instruction). In this case, the `MOV A, r` instruction after the `NOP` instruction is executed, and then the interrupt acknowledgement processing is performed.

Caution Interrupt requests will be held pending while interrupt request flag register 0 (`IF0`) or interrupt mask flag register 0 (`MK0`) is being accessed.

14.4.3 Multiple interrupt servicing

Multiple interrupt servicing in which another interrupt is acknowledged while an interrupt is being serviced can be performed using a priority order system. When two or more interrupts are generated at once, interrupt servicing is performed according to the priority assigned to each interrupt request in advance (see **Table 14-1**).

Figure 14-11. Example of Multiple Interrupts

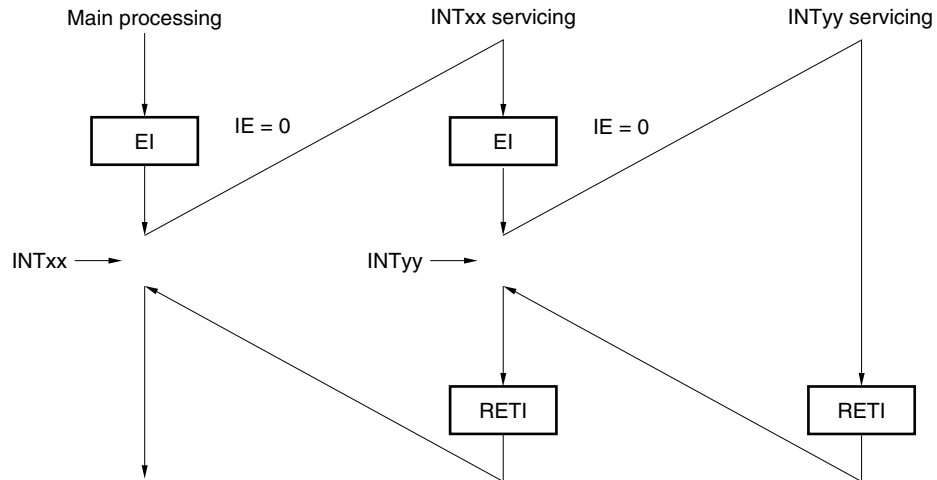
Example 1. A multiple interrupt is acknowledged

During interrupt INT_{xx} servicing, interrupt request INT_{yy} is acknowledged, and multiple interrupts are generated. The EI instruction is issued before each interrupt request acknowledgement, and the interrupt request acknowledgement enable state is set.

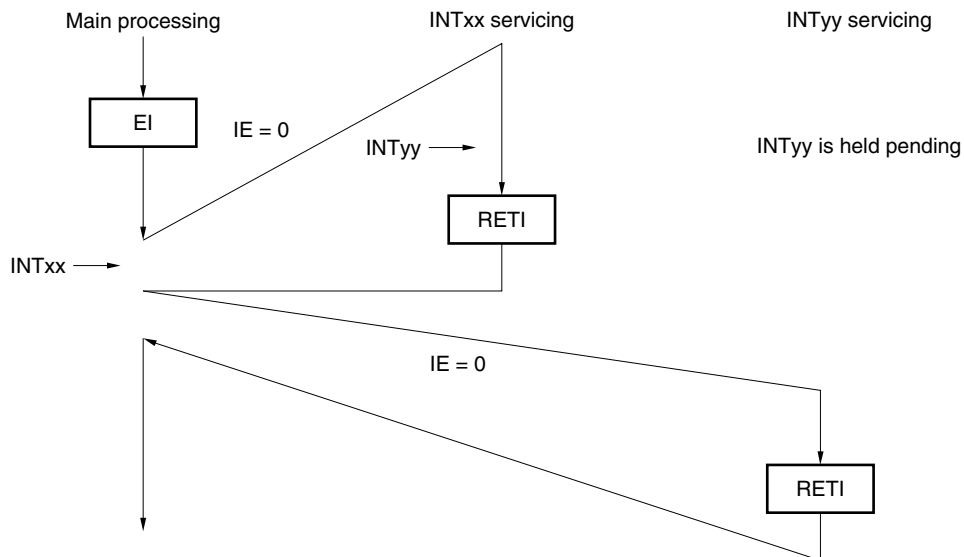
Example 2. Multiple interrupts are not generated because interrupts are not enabled

Because interrupts are not enabled in interrupt INT_{xx} servicing (the EI instruction is not issued), interrupt request INT_{yy} is not acknowledged, and multiple interrupts are not generated. The INT_{yy} request is held pending and acknowledged after the INT_{xx} servicing is performed.

IE = 0: Interrupt request acknowledgement disabled

14.4.4 Interrupt request pending

Some instructions may keep pending the acknowledgement of an instruction request until the completion of the execution of the next instruction even if the interrupt request (maskable interrupt, non-maskable interrupt, and external interrupt) is generated during the execution. The following shows such instructions (interrupt request pending instruction).

- Manipulation instruction for interrupt request flag register 0 (IF0)
- Manipulation instruction for interrupt mask flag register 0 (MK0)

CHAPTER 15 STANDBY FUNCTION

15.1 Standby Function and Configuration

15.1.1 Standby function

The standby function is used to reduce the power consumption of the system and can be effected in the following two modes:

(1) HALT mode

This mode is set when the HALT instruction is executed. HALT mode stops the operation clock of the CPU. The system clock oscillator continues oscillating. This mode does not reduce the current consumption as much as STOP mode, but is useful for resuming processing immediately when an interrupt request is generated, or for intermittent operations.

(2) STOP mode

This mode is set when the STOP instruction is executed. The STOP mode stops the main system clock oscillator and stops the entire system. The current consumption of the CPU can be substantially reduced in this mode.

The low voltage ($V_{DD} = 1.8 \text{ V min.}$) of the data memory can be retained. Therefore, this mode is useful for retaining the contents of the data memory at an extremely low current consumption.

STOP mode can be released by an interrupt request, so that this mode can be used for intermittent operation. However, some time is required until the system clock oscillator stabilizes after STOP mode has been released. If processing must be resumed immediately by using an interrupt request, therefore, use the HALT mode.

In both modes, the previous contents of the registers, flags, and data memory before setting standby mode are all retained. In addition, the statuses of the output latches of the I/O ports and output buffers are also retained.

Caution To set STOP mode, be sure to stop the operations of the peripheral hardware, and then execute the STOP instruction.

15.1.2 Standby function control register

The wait time after STOP mode is released upon interrupt request until the oscillation stabilizes is controlled with the oscillation stabilization time selection register (OSTS)^{Note}.

OSTS is set with an 8-bit memory manipulation instruction.

$\overline{\text{RESET}}$ input sets OSTS to 04H. However, the oscillation stabilization time after $\overline{\text{RESET}}$ release is $2^{15}/f_x$ in the $\mu\text{PD789052}$ and 78E9860A, and $2^7/f_{cc}$ in the $\mu\text{PD789062}$ and 78E9861A independent of OSTS.

Note $\mu\text{PD789052}$ Subseries only.

There is no oscillation stabilization time selection register in the $\mu\text{PD789062}$ Subseries. The oscillation stabilization time of the $\mu\text{PD789062}$ Subseries is fixed at $2^7/f_{cc}$.

Figure 15-1. Format of Oscillation Stabilization Time Selection Register

Symbol	7	6	5	4	3	2	1	0	Address	After reset	R/W
OSTS	0	0	0	0	0	OSTS2	OSTS1	OSTS0	FFFAH	04H	R/W

OSTS2	OSTS1	OSTS0	Oscillation stabilization time selection
0	0	0	$2^{12}/f_x$ (819 μs)
0	1	0	$2^{15}/f_x$ (6.55 ms)
1	0	0	$2^{17}/f_x$ (26.2 ms)
Other than above			Setting prohibited

Caution The wait time after STOP mode is released does not include the time from STOP mode release to clock oscillation start (“a” in the figure below), regardless of release by $\overline{\text{RESET}}$ input or by interrupt generation.

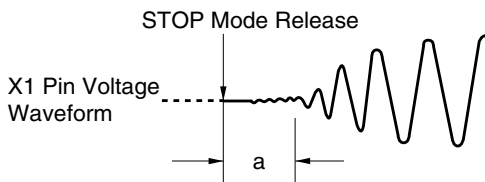

- Remarks**
1. f_x : System clock oscillation frequency (ceramic/crystal oscillation)
 2. The parenthesized values apply to operation at $f_x = 5.0$ MHz.

15.2 Standby Function Operation

15.2.1 HALT mode

(1) HALT mode

HALT mode is set by executing the HALT instruction.

The operation statuses in HALT mode are shown in the following table.

Table 15-1. Operation Statuses in HALT Mode

Item		HALT Mode Operation Status
System clock		System clock oscillation enabled Clock supply to CPU stopped
CPU		Operation stopped
EEPROM ^{Note 1}		Operation enabled ^{Note 2}
Port (output latch)		Remains in the state existing before HALT mode has been set
8-bit timer	TM30	Operation enabled
	TM40	Operation enabled
Watchdog timer		Operation enabled
Power-on-clear circuit ^{Note 1}	POC	Operation enabled ^{Note 3}
	LVI	Operation enabled
Bit sequential buffer		Operation enabled
Key return circuit		Operation stopped

Notes 1. μ PD78E9860A, 78E9861A only

2. HALT mode can be set after executing a write instruction.

3. When the POC circuit is set to operation enabled by the POC switching circuit in the μ PD78E9860A and 78E9861A.

(2) Releasing HALT mode

HALT mode can be released by the following three sources:

(a) Releasing by unmasked interrupt request

HALT mode is released by an unmasked interrupt request. In this case, if interrupt request acknowledgement is enabled, vectored interrupt servicing is performed. If interrupt acknowledgement is disabled, the instruction at the next address is executed.

Figure 15-2. Releasing HALT Mode by Interrupt

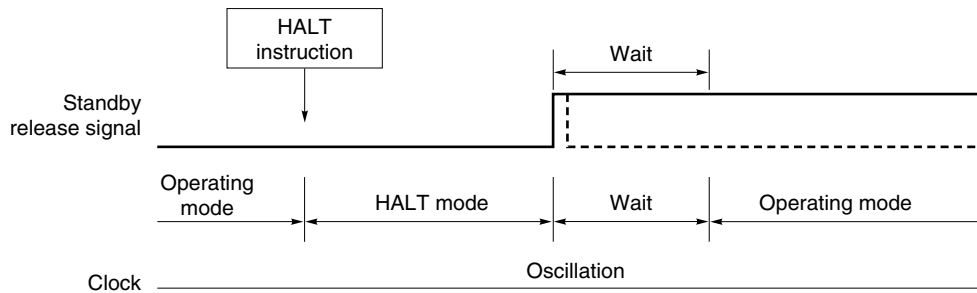

Remarks 1. The broken lines indicate the case where the interrupt request that has released standby mode is acknowledged.

2. The wait time is as follows:

- When vectored interrupt servicing is performed: 9 to 10 clocks
- When vectored interrupt servicing is not performed: 1 to 2 clocks

★

(b) Releasing by non-maskable interrupt request of watchdog timer

HALT mode is released regardless of whether interrupts are enabled or disabled, and vectored interrupt servicing is performed.

(c) Releasing by $\overline{\text{RESET}}$ input

When HALT mode is released by the $\overline{\text{RESET}}$ signal, execution branches to the reset vector address in the same manner as the ordinary reset operation, and program execution starts.

Figure 15-3. Releasing HALT Mode by $\overline{\text{RESET}}$ Input

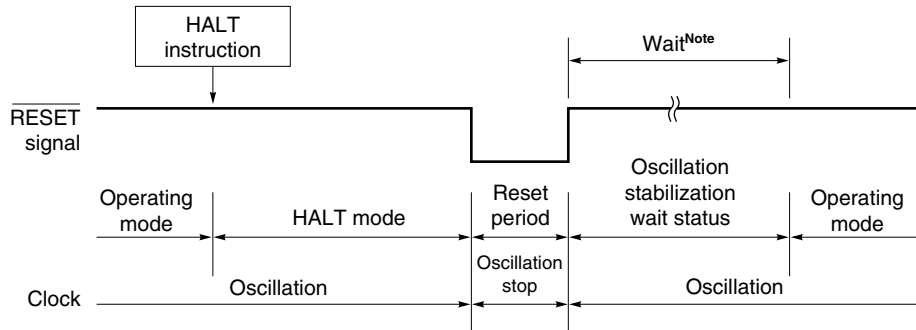

Note In the $\mu\text{PD789052}$ and 78E9860A , $2^{15}/f_x$: 6.55 ms (@ $f_x = 5.0$ MHz operation)
 In the $\mu\text{PD789062}$ and 78E9861A , $2^7/f_{cc}$: 128 μs (@ $f_{cc} = 1.0$ MHz operation)

- Remarks**
1. f_x : System clock oscillation frequency (ceramic/crystal oscillation)
 2. f_{cc} : System clock oscillation frequency (RC oscillation)

Table 15-2. Operation After Releasing HALT Mode

Releasing Source	MK $\times\times$	IE	Operation
Maskable interrupt request	0	0	Executes next address instruction.
	0	1	Executes interrupt servicing.
	1	\times	Retains HALT mode.
★ Non-maskable interrupt request of watchdog timer	–	\times	Executes interrupt servicing.
$\overline{\text{RESET}}$ input	–	–	Reset processing

\times : don't care

15.2.2 STOP mode

(1) Setting and operation status of STOP mode

STOP mode is set by executing the STOP instruction.

Caution Because standby mode can be released by an interrupt request signal, standby mode is released as soon as it is set if there is an interrupt source whose interrupt request flag is set and interrupt mask flag is reset. When STOP mode is set, therefore, HALT mode is set immediately after the STOP instruction has been executed, the wait time set by the oscillation stabilization time, and then the operation mode is set.

The operation statuses in STOP mode are shown in the following table.

Table 15-3. Operation Statuses in STOP Mode

Item		STOP Mode Operation Status
System clock		System clock oscillation stopped Clock supply to CPU stopped
CPU		Operation stopped
EEPROM ^{Note 1}		Operation stopped
Port (output latch)		Remains in the state existing before STOP mode has been set
8-bit timer	TM30	Operation enabled ^{Note 2}
	TM40	Operation enabled ^{Note 3}
Watchdog timer		Operation stopped
Power-on-clear circuit ^{Note 1}	POC	Operation enabled ^{Note 4}
	LVI	Operation stopped
Bit sequential buffer		Operation enabled ^{Note 5}
Key return circuit		Operation enabled

Notes 1. μ PD78E9860A, 78E9861A only

2. Operation enabled only when cascade connected with TM40 (external clock selected for count clock)
3. Operation enabled only when external clock is selected for count clock
4. When the POC circuit is set to operation enabled by the POC switching circuit in the μ PD78E9860A and 78E9861A.
5. Operation enabled only when external clock is selected for TM40 count clock and INTTM40 occurs

(2) **Releasing STOP mode**

STOP mode can be released by the following two sources:

(a) **Releasing by unmasked interrupt request**

STOP mode is released by an unmasked interrupt request. In this case, vectored interrupt servicing is performed if interrupt acknowledgement is enabled after the oscillation stabilization time has elapsed. If interrupt acknowledgement is disabled, the instruction at the next address is executed.

Figure 15-4. Releasing STOP Mode by Interrupt

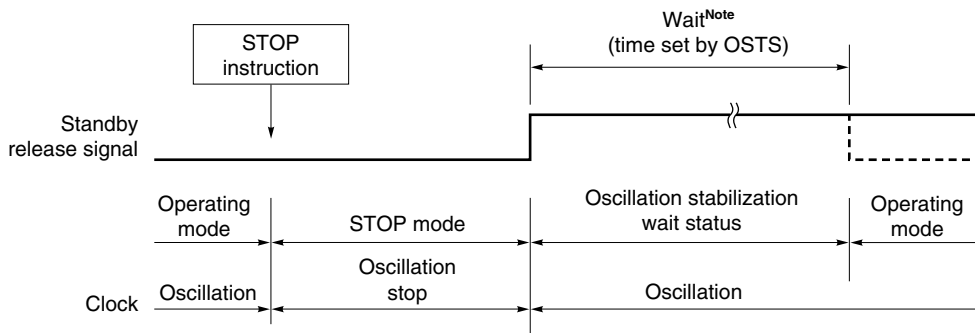

Note There is no OSTs in the μ PD789062 Subseries, and the wait is fixed at $2^7/f_{cc}$.

Remark The broken lines indicate the case where the interrupt request that has released standby mode is acknowledged.

- ★ (b) **Releasing by non-maskable interrupt request of key return**
 STOP mode is released regardless of whether interrupts are enabled or disabled, and vectored interrupt servicing is performed.

(b) Releasing by $\overline{\text{RESET}}$ input

When STOP mode is released by the $\overline{\text{RESET}}$ signal, the reset operation is performed after the oscillation stabilization time has elapsed.

Figure 15-5. Releasing STOP Mode by $\overline{\text{RESET}}$ Input

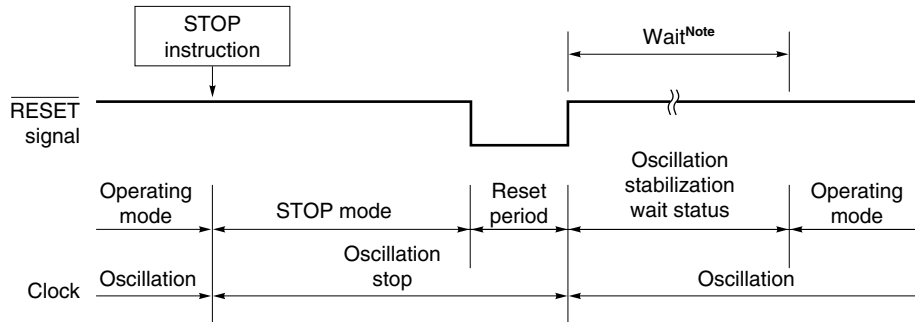

Note In the $\mu\text{PD789052}$ and 78E9860A , $2^{15}/f_x$: 6.55 ms (@ $f_x = 5.0$ MHz operation)
 In the $\mu\text{PD789062}$ and 78E9861A , $2^7/f_{cc}$: 128 μs (@ $f_{cc} = 1.0$ MHz operation)

Remarks 1. f_x : System clock oscillation frequency (ceramic/crystal oscillation)
 2. f_{cc} : System clock oscillation frequency (RC oscillation)

Table 15-4. Operation After Releasing STOP Mode

Releasing Source	MK $\times\times$	IE	Operation
Maskable interrupt request	0	0	Executes next address instruction.
	0	1	Executes interrupt servicing.
	1	\times	Retains STOP mode.
★ Non-maskable interrupt request of key return	–	\times	Executes interrupt servicing.
$\overline{\text{RESET}}$ input	–	–	Reset processing

\times : don't care

CHAPTER 16 RESET FUNCTION

The following three operations are available to generate reset signals.

- (1) External reset input by $\overline{\text{RESET}}$ signal input
- (2) Internal reset by watchdog timer inadvertent program loop time detection
- (3) Internal reset by comparison of POC circuit power supply voltage and detection voltage^{Note}

External reset and internal reset have no functional differences. In both cases, program execution starts at the address at 0000H and 0001H by reset signal input.

When a low level is input to the $\overline{\text{RESET}}$ pin, the watchdog timer overflows, or POC circuit^{Note} voltage is detected, a reset is applied and each hardware is set to the status shown in Table 16-1. Each pin is high impedance during reset input or during the oscillation stabilization time just after reset clear.

When a high level is input to the $\overline{\text{RESET}}$ pin, the reset is cleared and program execution is started after the oscillation stabilization time has elapsed. The reset applied by the watchdog timer overflow is automatically cleared after reset, and program execution is started after the oscillation stabilization time has elapsed (see **Figures 16-2** through **16-4**).

Note PD78E9860A, 78E9861A only

- Cautions**
1. For an external reset, input a low level of 10 μs or more to the $\overline{\text{RESET}}$ pin.
 2. When STOP mode is cleared by reset, the STOP mode contents are held during reset input. However, the port pins become high impedance.

Figure 16-1. Block Diagram of Reset Function

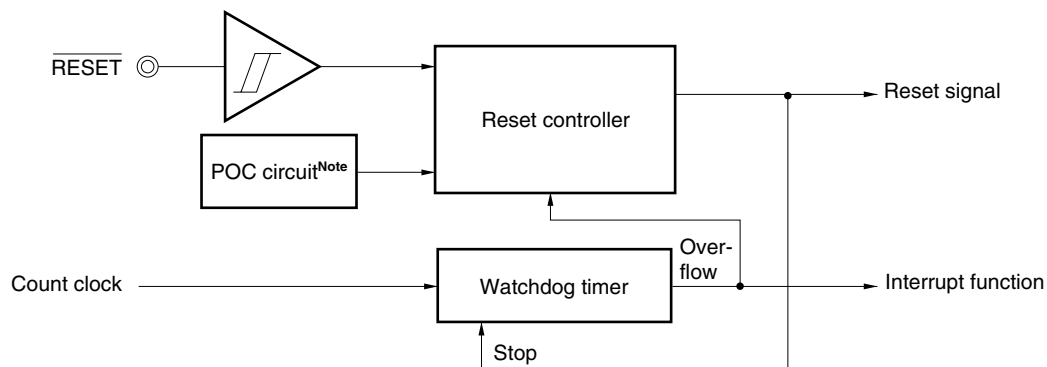

Note PD78E9860A, 78E9861A only

Figure 16-2. Reset Timing by $\overline{\text{RESET}}$ Input

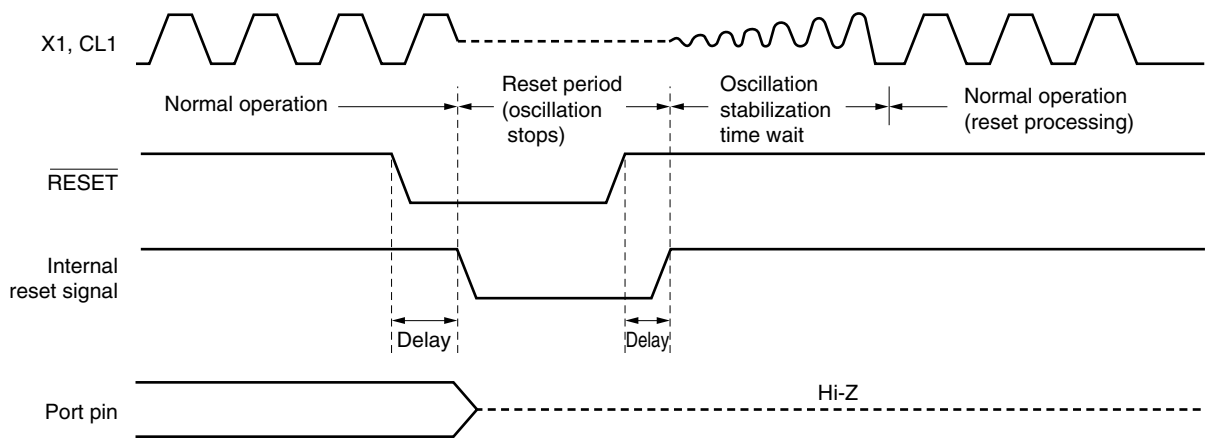

Figure 16-3. Reset Timing by Watchdog Timer Overflow

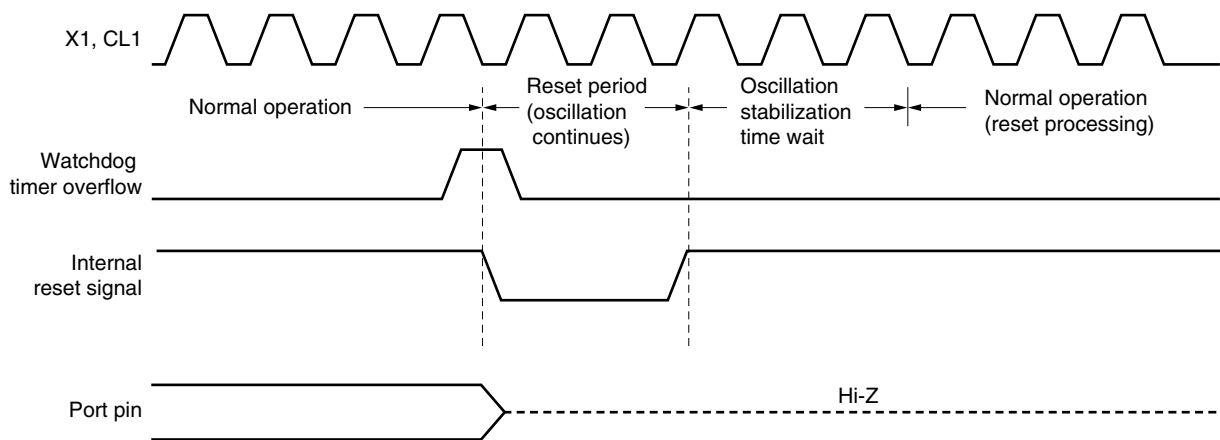
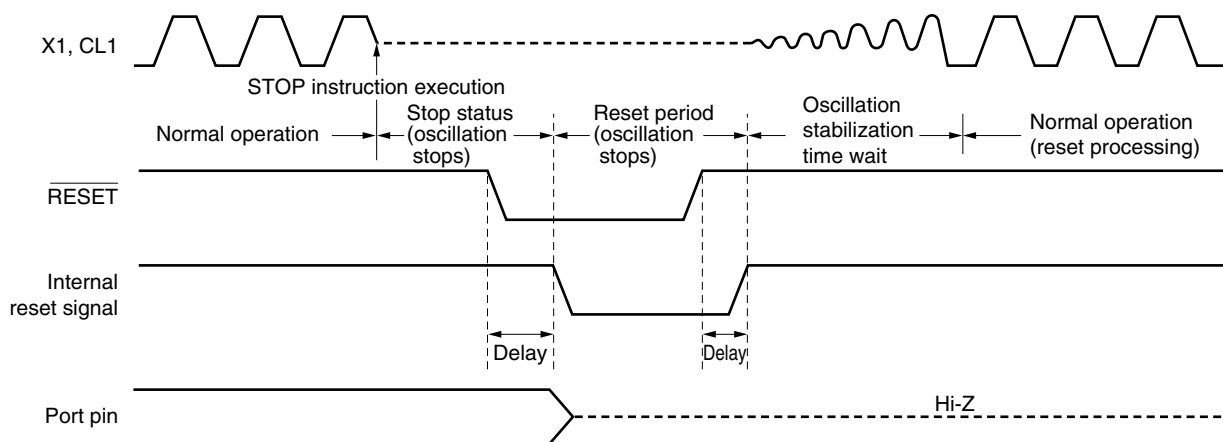

Figure 16-4. Reset Timing by $\overline{\text{RESET}}$ Input in STOP Mode



Remark For the reset timing of the power-on-clear circuit, see **CHAPTER 11 POWER-ON-CLEAR CIRCUITS (PD78E9860A, 78E9861A ONLY).**

Table 16-1. Status of Hardware After Reset

Hardware		Status After Reset
Program counter (PC) ^{Note 1}		The contents of the reset vector table (0000H, 0001H) are set
Stack pointer (SP)		Undefined
Program status word (PSW)		02H
EEPROM ^{Note 2}	Write control register (EEWC10)	08H
RAM	Data memory	Undefined ^{Note 3}
	General-purpose registers	Undefined ^{Note 3}
Ports (P0, P2) (output latch)		00H
Port mode registers (PM0, PM2)		FFH
Processor clock control register (PCC)		02H
Oscillation stabilization time selection register (OSTS) ^{Note 4}		04H
8-bit timer	Timer counters (TM30, TM40)	00H
	Compare registers (CR30, CR40, CRH40)	Undefined
	Mode control registers (TMC30, TMC40)	00H
	Carrier generator output control register (TCA40)	00H
Watchdog timer	Timer clock selection register (TCL2)	00H
	Mode register (WDTM)	00H
Power-on-clear circuit ^{Note 2}	Power-on-clear register (POCF1)	00H ^{Note 5}
	Low-voltage detection register (LVIF1)	00H
	Low-voltage detection level selection register (LVIS1)	00H
Bit sequential buffer	Data registers (BSFRL10, BSFRH10)	Undefined
	Output control register (BSFC10)	00H
Interrupts	Request flag register (IF0)	00H
	Mask flag register (MK0)	FFH

Notes 1. While a reset signal is being input, and during the oscillation stabilization time wait, the contents of the PC will be undefined, while the remainder of the hardware will be the same as after the reset.

2. PD78E9860A, 78E9861A only

3. In standby mode, the RAM enters the hold state after a reset.

4. PD789052 Subseries only

5. This value is 04H only after a power-on-clear reset.

CHAPTER 17 μ PD78E9860A, 78E9861A

EEPROM versions in the μ PD789052, 789062 Subseries include the μ PD78E9860A and 78E9861A.

The μ PD78E9860A replaces the internal ROM of the μ PD789052 with EEPROM. The μ PD78E9861A replaces the internal ROM of the μ PD789062 with EEPROM. The differences between the μ PD78E9860A, 78E9861A and the mask ROM versions are shown in Table 17-1.

Table 17-1. Differences Between μ PD78E9860A, 78E9861A and Mask ROM Versions

Item			Part Number		EEPROM Versions		Mask ROM Versions	
			μ PD78E9860A	μ PD78E9861A	μ PD789052	μ PD789062		
Internal memory	Program memory	ROM structure	EEPROM			Mask ROM		
		ROM capacity	4 KB					
	Data memory	High-speed RAM	128 bytes					
		EEPROM	32 bytes			Not provided		
System clock			Ceramic/crystal oscillation	RC oscillation	Ceramic/crystal oscillation	RC oscillation		
IC pin			Not provided			Provided		
V _{PP} pin			Provided			Not provided		
P40 to P43 pull-up resistor by mask option			Not provided			Provided		
POC circuit selection by mask option			Not provided			Provided		
★	Oscillation stabilization time after STOP mode is released by interrupt request		Can select $2^{12}/f_x$, $2^{15}/f_x$, or $2^{17}/f_x$ by OSTS register	$2^7/f_{cc}$	Can select $2^{12}/f_x$, $2^{15}/f_x$, or $2^{17}/f_x$ by OSTS register	$2^7/f_{cc}$		
★	Oscillation stabilization time after STOP mode release by RESET or reset release via POC circuit		$2^{15}/f_x$	$2^7/f_{cc}$	$2^{15}/f_x$	$2^7/f_{cc}$		
Power supply voltage			V _{DD} = 1.8 to 5.5 V	V _{DD} = 1.8 to 3.6 V	V _{DD} = 1.8 to 5.5 V	V _{DD} = 1.8 to 3.6 V		
Electrical specifications			Refer to CHAPTER 20 ELECTRICAL SPECIFICATIONS					

Caution There are differences in noise immunity and noise radiation between the EEPROM and mask ROM versions. When pre-producing an application set with the EEPROM version and then mass-producing it with the mask ROM version, be sure to conduct sufficient evaluations for the commercial samples (not engineering samples) of the mask ROM version.

17.1 EEPROM (Program Memory)

The on-chip program memory in the μ PD78E9860A and 78E9861A is EEPROM.

This chapter describes the functions of the EEPROM incorporated in the program memory area. For the EEPROM incorporated in data memory, see **CHAPTER 5 EEPROM (DATA MEMORY) (μ PD78E9860A, 78E9861A ONLY)**.

EEPROM can be written with the μ PD78E9860A and 78E9861A mounted on the target system (on-board). Connect the dedicated flash writer (Flashpro III (part no. FL-PR3, PG-FP3)/Flashpro IV (part no. FL-PR4, PG-FP4)) to the host machine and target system to write to EEPROM.

Remark FL-PR3 and FL-PR4 are products of Naito Densai Machida Mfg. Co., Ltd (TEL +81-45-475-4191).

Programming using EEPROM has the following advantages.

- Software can be modified after the microcontroller is solder-mounted on the target system.
- Distinguishing software facilities small-quantity, varied model production
- Easy data adjustment when starting mass production

17.1.1 Programming environment

The following shows the environment required for μ PD78E9860A, 78E9861A EEPROM programming.

When Flashpro III (part no. FL-PR3, PG-FP3) or Flashpro IV (part no. FL-PR4, PG-FP4) is used as a dedicated flash programmer, a host machine is required to control the dedicated flash programmer. Communication between the host machine and flash programmer is performed via RS-232C/USB (Rev. 1.1).

For details, refer to the manuals for Flashpro III/Flashpro IV.

Remark USB is supported by Flashpro IV only.

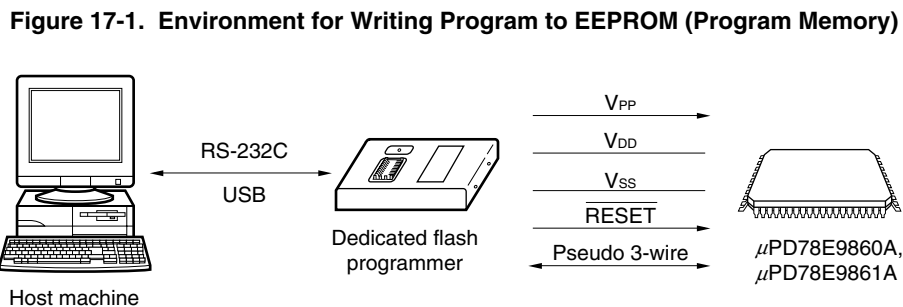

17.1.2 Communication mode

Use the communication mode shown in Table 17-2 to perform communication between the dedicated flash programmer and μ PD78E9860A, 78E9861A.

Table 17-2. Communication Mode List

Communication Mode	TYPE Setting ^{Note 1}				Multiple Rate	Pins Used	Number of V _{PP} Pulses
	COMM PORT	SIO Clock	CPU CLOCK ^{Note 2}				
			In Flashpro	On Target Board			
Pseudo 3-wire	Port A (Pseudo-3 wire)	100 Hz to 1 kHz	1, 2, 4, 5 MHz ^{Notes 3, 4}	1 to 5 MHz ^{Note 3}	1.0	P02 (serial data input) P01 (serial data output) P00 (serial clock input)	12

- Notes**
1. Selection items for TYPE settings on the dedicated flash programmer (Flashpro III / Flashpro IV).
 2. Be sure to use In Flashpro (system clock is supplied from a dedicated flash writer) with the μ PD78E9861A.
 3. The possible setting range differs depending on the voltage. For details, see **CHAPTER 20 ELECTRICAL SPECIFICATIONS**.
 4. 2 or 4 MHz only with Flashpro III

Figure 17-2. Communication Mode Selection Format

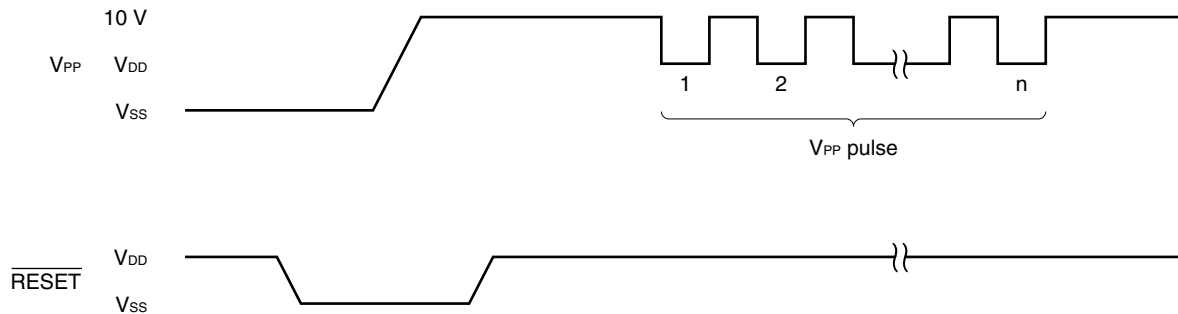
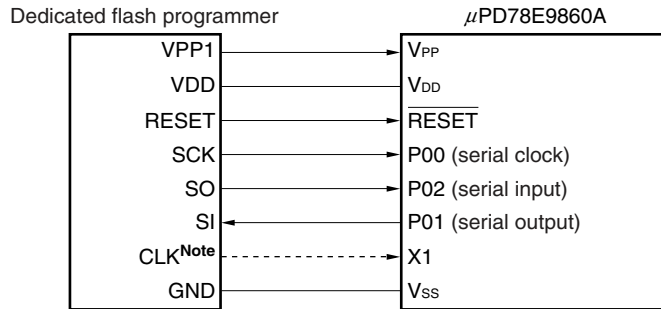
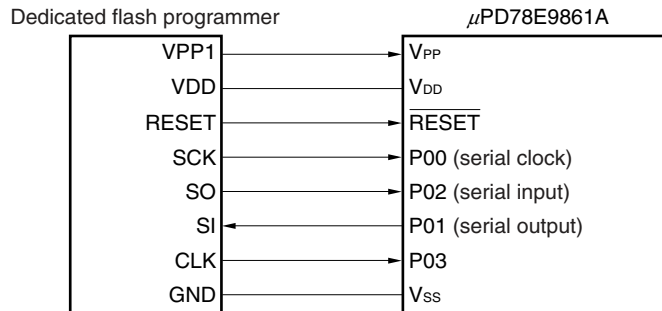

Figure 17-3. Example of Connection with Dedicated Flash Programmer

(a) Pseudo 3-wire (μ PD78E9860A)(b) Pseudo 3-wire (μ PD78E9861A)

Note When supplying the system clock from a dedicated flash writer, connect the CLK and X1 pins and cut off the resonator on the board. When using the clock oscillated by the on-board resonator, do not connect the CLK pin.

Caution The V_{DD} pin, if already connected to the power supply, must be connected to the VDD pin of the dedicated flash programmer. When using the power supply connected to the VDD pin, supply voltage before starting programming.

If Flashpro III (part no. FL-PR3, PG-FP3)/Flashpro IV (part no. FL-PR4, PG-FP4) is used as a dedicated flash programmer, the following signals are generated for the μ PD78E9860A, 78E9861A. For details, refer to the manual of Flashpro III/Flashpro IV.

Table 17-3. Pin Connection List

Signal Name	I/O	Pin Function	Pin Name	Pseudo 3-Wire
VPP1	Output	Write voltage	V _{PP}	⊙
VPP2	–	–	–	×
VDD	I/O	V _{DD} voltage generation/voltage monitoring	V _{DD}	⊙ ^{Note}
GND	–	Ground	V _{SS}	⊙
CLK	Output	Clock output	X1 (μ PD78E9860A)	○
			P03 (μ PD78E9861A)	⊙
RESET	Output	Reset signal	$\overline{\text{RESET}}$	⊙
SI	Input	Receive signal	P01	⊙
SO	Output	Transmit signal	P02	⊙
SCK	Output	Transfer clock	P00	⊙
HS	Input	Handshake signal	–	×

Note V_{DD} voltage must be supplied before programming is started.

Remark ⊙: Pin must be connected.

○: If the signal is supplied on the target board, pin does not need to be connected.

×: Pin does not need to be connected.

17.1.3 On-board pin processing

When performing programming on the target system, provide a connector on the target system to connect the dedicated flash programmer.

An on-board function that allows switching between normal operation mode and EEPROM programming mode may be required in some cases.

<V_{PP} pin>

In normal operation mode, input 0 V to the V_{PP} pin. In EEPROM programming mode, a write voltage of 10.0 V (TYP.) is supplied to the V_{PP} pin, so perform either of the following.

- (1) Connect a pull-down resistor $R_{V_{PP}} = 10\text{ k}\Omega$ to the V_{PP} pin.
- (2) Use the jumper on the board to switch the V_{PP} pin input to either the programmer or directly to GND.

A V_{PP} pin connection example is shown below.

Figure 17-4. V_{PP} Pin Connection Example

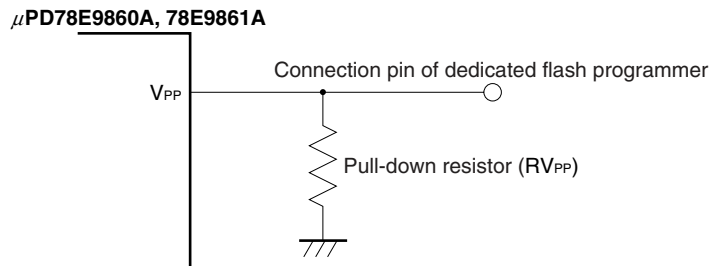

<Serial interface pins>

The following shows the pins used by the serial interface.

Serial Interface	Pins Used
Pseudo 3-wire	P02, P01, P00

When connecting the dedicated flash programmer to a serial interface pin that is connected to another device on-board, signal conflict or abnormal operation of the other device may occur. Care must therefore be taken with such connections.

(1) Signal conflict

If the dedicated flash programmer (output) is connected to a serial interface pin (input) that is connected to another device (output), a signal conflict occurs. To prevent this, isolate the connection with the other device or set the other device to the output high impedance status.

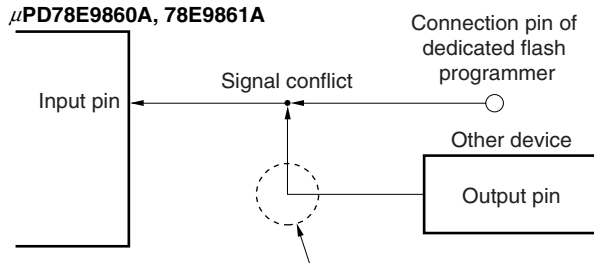
Figure 17-5. Signal Conflict (Input Pin of Serial Interface)

In the EEPROM programming mode, the signal output by another device and the signal sent by the dedicated flash programmer conflict; therefore, isolate the signal of the other device.

(2) Abnormal operation of other device

If the dedicated flash programmer (output or input) is connected to a serial interface pin (input or output) that is connected to another device (input), a signal is output to the device, and this may cause an abnormal operation. To prevent this abnormal operation, isolate the connection with the other device or set so that the signals input to the other device are ignored.

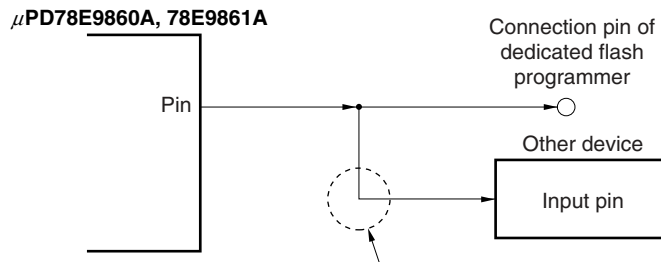
Figure 17-6. Abnormal Operation of Other Device

If the signal output by the μ PD78E9860A, 78E9861A affects another device in the EEPROM programming mode, isolate the signals of the other device.

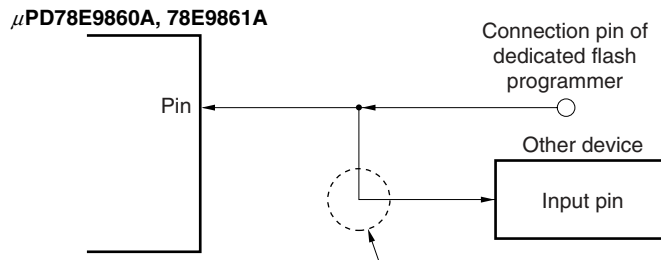

If the signal output by the dedicated flash programmer affects another device in the EEPROM programming mode, isolate the signals of the other device.

<RESET pin>

If the reset signal of the dedicated flash programmer is connected to the $\overline{\text{RESET}}$ pin connected to the reset signal generator on-board, a signal conflict occurs. To prevent this, isolate the connection with the reset signal generator.

If the reset signal is input from the user system in the EEPROM programming mode, a normal programming operation cannot be performed. Therefore, do not input other than reset signals from the dedicated flash programmer.

Figure 17-7. Signal Conflict ($\overline{\text{RESET}}$ Pin)

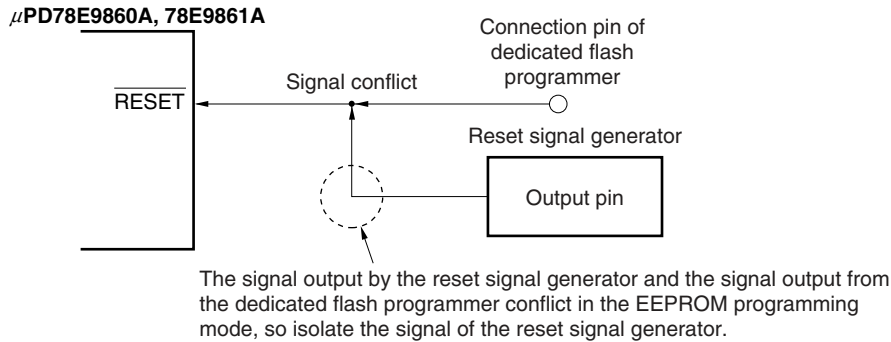

<Port pins>

When the μ PD78E9860A and 78E9861A enter the EEPROM programming mode, all the pins other than those that communicate with the flash programmer are in the same status as immediately after reset.

If the external device does not recognize initial statuses such as the output high impedance status, therefore, connect the external device to V_{DD} or V_{SS} via a resistor.

<Oscillator>

- In μ PD78E9860A

When using the on-board clock, connect X1 and X2 as required in the normal operation mode.

When using the clock output of the flash programmer, connect it directly to X1, disconnecting the main resonator on-board, and leave the X2 pin open.

- In μ PD78E9861A

Connect CL1 and CL2 as required in the normal operation mode, and connect the clock output of the flash programmer to the P03 pin.

<Power supply>

To use the power output from the flash programmer, connect the V_{DD} pin to VDD of the flash programmer, and the V_{SS} pin to GND of the flash programmer.

To use the on-board power supply, make connections that accord with the normal operation mode. However, because the voltage is monitored by the flash programmer, be sure to connect VDD of the flash programmer.

17.1.4 Connection of adapter for flash memory (EEPROM) writing

The following figures show the examples of recommended connection when the adapter for flash memory (EEPROM) writing is used.

Figure 17-8. Wiring Example for Flash Memory (EEPROM) Writing Adapter with Pseudo 3-Wire (1/2)

(a) μ PD78E9860A

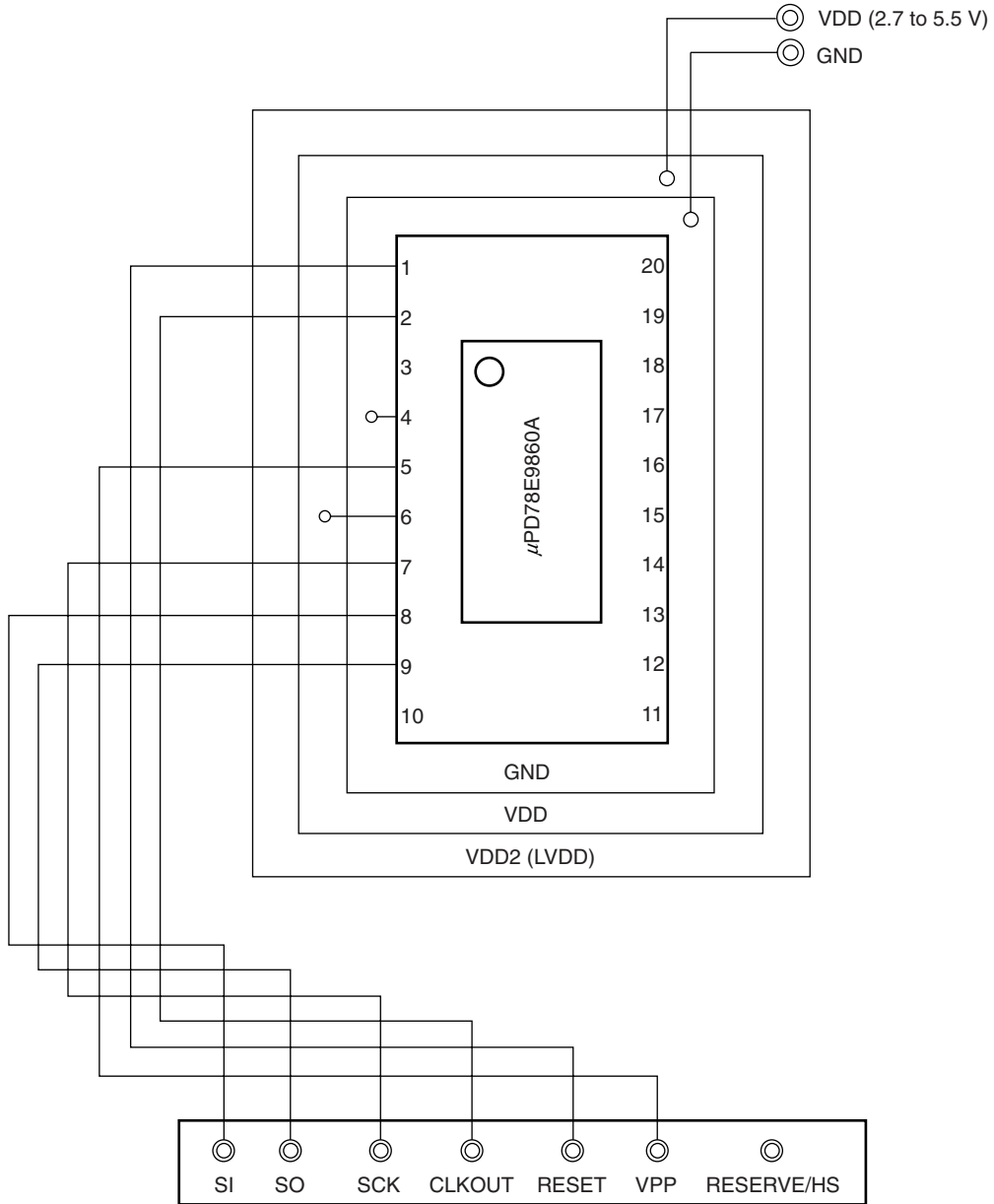
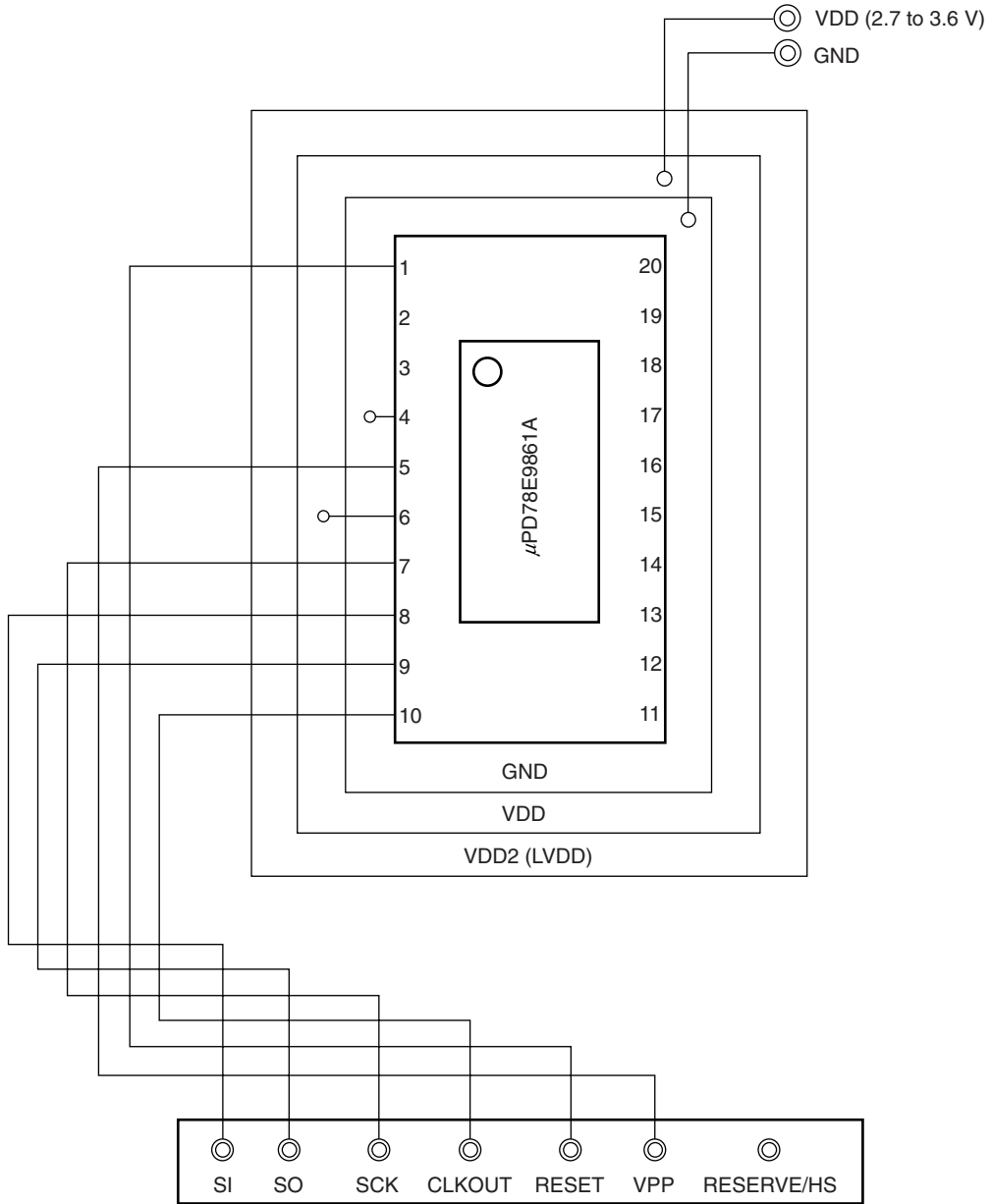

Figure 17-8. Wiring Example for Flash Memory (EEPROM) Writing Adapter with Pseudo 3-Wire (2/2)

(b) μ PD78E9861A



CHAPTER 18 MASK OPTIONS

The PD789052 and 789062 have the following mask options.

- P40 to P43 mask options
On-chip pull-up resistors can be selected in bit units.
 - <1> Specify on-chip pull-up resistors
 - <2> Do not specify on-chip pull-up resistors

CHAPTER 19 INSTRUCTION SET OVERVIEW

This chapter lists the instruction set of the μ PD789052, 789062 Subseries. For details of the operation and machine language (instruction code) of each instruction, refer to **78K/0S Series Instructions User's Manual (U11047E)**.

19.1 Operation

19.1.1 Operand identifiers and description methods

Operands are described in "Operand" column of each instruction in accordance with the description method of the instruction operand identifier (refer to the assembler specifications for details). When there are two or more description methods, select one of them. Uppercase letters and the symbols #, !, \$, and [] are key words and are described as they are. Each symbol has the following meaning.

- #: Immediate data specification
- !: Absolute address specification
- \$: Relative address specification
- []: Indirect address specification

In the case of immediate data, describe an appropriate numeric value or a label. When using a label, be sure to describe the #, !, \$ and [] symbols.

For operand register identifiers, r and rp, either function names (X, A, C, etc.) or absolute names (names in parentheses in the table below, R0, R1, R2, etc.) can be used for description.

Table 19-1. Operand Identifiers and Description Methods

Identifier	Description Method
r rp sfr	X (R0), A (R1), C (R2), B (R3), E (R4), D (R5), L (R6), H (R7) AX (RP0), BC (RP1), DE (RP2), HL (RP3) Special function register symbol
saddr saddrp	FE20H to FF1FH Immediate data or labels FE20H to FF1FH Immediate data or labels (even addresses only)
addr16 addr5	0000H to FFFFH Immediate data or labels (only even addresses for 16-bit data transfer instructions) 0040H to 007FH Immediate data or labels (even addresses only)
word byte bit	16-bit immediate data or label 8-bit immediate data or label 3-bit immediate data or label

Remark For symbols of special function registers, see **Table 4-3 Special Function Registers**.

19.1.2 Description of “Operation” column

A:	A register; 8-bit accumulator
X:	X register
B:	B register
C:	C register
D:	D register
E:	E register
H:	H register
L:	L register
AX:	AX register pair; 16-bit accumulator
BC:	BC register pair
DE:	DE register pair
HL:	HL register pair
PC:	Program counter
SP:	Stack pointer
PSW:	Program status word
CY:	Carry flag
AC:	Auxiliary carry flag
Z:	Zero flag
IE:	Interrupt request enable flag
NMIS:	Flag indicating non-maskable interrupt servicing in progress
():	Memory contents indicated by address or register contents in parentheses
× _H , × _L :	Higher 8 bits and lower 8 bits of 16-bit register
∧:	Logical product (AND)
∨:	Logical sum (OR)
⊕:	Exclusive logical sum (exclusive OR)
—:	Inverted data
addr16:	16-bit immediate data or label
jdisp8:	Signed 8-bit data (displacement value)

19.1.3 Description of “Flag” column

(Blank):	Unchanged
0:	Cleared to 0
1:	Set to 1
×:	Set/cleared according to the result
R:	Previously saved value is stored

19.2 Operation List

Mnemonic	Operand	Bytes	Clocks	Operation	Flag		
					Z	AC	CY
MOV	r, #byte	3	6	$r \leftarrow \text{byte}$			
	saddr, #byte	3	6	$(\text{saddr}) \leftarrow \text{byte}$			
	sfr, #byte	3	6	$\text{sfr} \leftarrow \text{byte}$			
	A, r <small>Note 1</small>	2	4	$A \leftarrow r$			
	r, A <small>Note 1</small>	2	4	$r \leftarrow A$			
	A, saddr	2	4	$A \leftarrow (\text{saddr})$			
	saddr, A	2	4	$(\text{saddr}) \leftarrow A$			
	A, sfr	2	4	$A \leftarrow \text{sfr}$			
	sfr, A	2	4	$\text{sfr} \leftarrow A$			
	A, !addr16	3	8	$A \leftarrow (\text{addr16})$			
	!addr16, A	3	8	$(\text{addr16}) \leftarrow A$			
	PSW, #byte	3	6	$\text{PSW} \leftarrow \text{byte}$	×	×	×
	A, PSW	2	4	$A \leftarrow \text{PSW}$			
	PSW, A	2	4	$\text{PSW} \leftarrow A$	×	×	×
	A, [DE]	1	6	$A \leftarrow (\text{DE})$			
	[DE], A	1	6	$(\text{DE}) \leftarrow A$			
	A, [HL]	1	6	$A \leftarrow (\text{HL})$			
	[HL], A	1	6	$(\text{HL}) \leftarrow A$			
	A, [HL + byte]	2	6	$A \leftarrow (\text{HL} + \text{byte})$			
	[HL + byte], A	2	6	$(\text{HL} + \text{byte}) \leftarrow A$			
XCH	A, X	1	4	$A \leftrightarrow X$			
	A, r <small>Note 2</small>	2	6	$A \leftrightarrow r$			
	A, saddr	2	6	$A \leftrightarrow (\text{saddr})$			
	A, sfr	2	6	$A \leftrightarrow \text{sfr}$			
	A, [DE]	1	8	$A \leftrightarrow (\text{DE})$			
	A, [HL]	1	8	$A \leftrightarrow (\text{HL})$			
	A, [HL, byte]	2	8	$A \leftrightarrow (\text{HL} + \text{byte})$			

- Notes**
1. Except $r = A$.
 2. Except $r = A, X$.

Remark One instruction clock cycle is one CPU clock cycle (f_{CPU}) selected by the processor clock control register (PCC).

Mnemonic	Operand	Bytes	Clocks	Operation	Flag		
					Z	AC	CY
MOVW	rp, #word	3	6	$rp \leftarrow \text{word}$			
	AX, saddrp	2	6	$AX \leftarrow (\text{saddrp})$			
	saddrp, AX	2	8	$(\text{saddrp}) \leftarrow AX$			
	AX, rp <small>Note</small>	1	4	$AX \leftarrow rp$			
	rp, AX <small>Note</small>	1	4	$rp \leftarrow AX$			
XCHW	AX, rp <small>Note</small>	1	8	$AX \leftrightarrow rp$			
ADD	A, #byte	2	4	$A, CY \leftarrow A + \text{byte}$	x	x	x
	saddr, #byte	3	6	$(\text{saddr}), CY \leftarrow (\text{saddr}) + \text{byte}$	x	x	x
	A, r	2	4	$A, CY \leftarrow A + r$	x	x	x
	A, saddr	2	4	$A, CY \leftarrow A + (\text{saddr})$	x	x	x
	A, !addr16	3	8	$A, CY \leftarrow A + (\text{addr16})$	x	x	x
	A, [HL]	1	6	$A, CY \leftarrow A + (\text{HL})$	x	x	x
	A, [HL + byte]	2	6	$A, CY \leftarrow A + (\text{HL} + \text{byte})$	x	x	x
ADDC	A, #byte	2	4	$A, CY \leftarrow A + \text{byte} + CY$	x	x	x
	saddr, #byte	3	6	$(\text{saddr}), CY \leftarrow (\text{saddr}) + \text{byte} + CY$	x	x	x
	A, r	2	4	$A, CY \leftarrow A + r + CY$	x	x	x
	A, saddr	2	4	$A, CY \leftarrow A + (\text{saddr}) + CY$	x	x	x
	A, !addr16	3	8	$A, CY \leftarrow A + (\text{addr16}) + CY$	x	x	x
	A, [HL]	1	6	$A, CY \leftarrow A + (\text{HL}) + CY$	x	x	x
	A, [HL + byte]	2	6	$A, CY \leftarrow A + (\text{HL} + \text{byte}) + CY$	x	x	x
SUB	A, #byte	2	4	$A, CY \leftarrow A - \text{byte}$	x	x	x
	saddr, #byte	3	6	$(\text{saddr}), CY \leftarrow (\text{saddr}) - \text{byte}$	x	x	x
	A, r	2	4	$A, CY \leftarrow A - r$	x	x	x
	A, saddr	2	4	$A, CY \leftarrow A - (\text{saddr})$	x	x	x
	A, !addr16	3	8	$A, CY \leftarrow A - (\text{addr16})$	x	x	x
	A, [HL]	1	6	$A, CY \leftarrow A - (\text{HL})$	x	x	x
	A, [HL + byte]	2	6	$A, CY \leftarrow A - (\text{HL} + \text{byte})$	x	x	x

Note Only when rp = BC, DE, or HL.

Remark One instruction clock cycle is one CPU clock cycle (f_{CPU}) selected by the processor clock control register (PCC).

Mnemonic	Operand	Bytes	Clocks	Operation	Flag		
					Z	AC	CY
SUBC	A, #byte	2	4	$A, CY \leftarrow A - \text{byte} - CY$	x	x	x
	saddr, #byte	3	6	$(saddr), CY \leftarrow (saddr) - \text{byte} - CY$	x	x	x
	A, r	2	4	$A, CY \leftarrow A - r - CY$	x	x	x
	A, saddr	2	4	$A, CY \leftarrow A - (saddr) - CY$	x	x	x
	A, !addr16	3	8	$A, CY \leftarrow A - (\text{addr16}) - CY$	x	x	x
	A, [HL]	1	6	$A, CY \leftarrow A - (\text{HL}) - CY$	x	x	x
	A, [HL + byte]	2	6	$A, CY \leftarrow A - (\text{HL} + \text{byte}) - CY$	x	x	x
AND	A, #byte	2	4	$A \leftarrow A \wedge \text{byte}$	x		
	saddr, #byte	3	6	$(saddr) \leftarrow (saddr) \wedge \text{byte}$	x		
	A, r	2	4	$A \leftarrow A \wedge r$	x		
	A, saddr	2	4	$A \leftarrow A \wedge (saddr)$	x		
	A, !addr16	3	8	$A \leftarrow A \wedge (\text{addr16})$	x		
	A, [HL]	1	6	$A \leftarrow A \wedge (\text{HL})$	x		
	A, [HL + byte]	2	6	$A \leftarrow A \wedge (\text{HL} + \text{byte})$	x		
OR	A, #byte	2	4	$A \leftarrow A \vee \text{byte}$	x		
	saddr, #byte	3	6	$(saddr) \leftarrow (saddr) \vee \text{byte}$	x		
	A, r	2	4	$A \leftarrow A \vee r$	x		
	A, saddr	2	4	$A \leftarrow A \vee (saddr)$	x		
	A, !addr16	3	8	$A \leftarrow A \vee (\text{addr16})$	x		
	A, [HL]	1	6	$A \leftarrow A \vee (\text{HL})$	x		
	A, [HL + byte]	2	6	$A \leftarrow A \vee (\text{HL} + \text{byte})$	x		
XOR	A, #byte	2	4	$A \leftarrow A \oplus \text{byte}$	x		
	saddr, #byte	3	6	$(saddr) \leftarrow (saddr) \oplus \text{byte}$	x		
	A, r	2	4	$A \leftarrow A \oplus r$	x		
	A, saddr	2	4	$A \leftarrow A \oplus (saddr)$	x		
	A, !addr16	3	8	$A \leftarrow A \oplus (\text{addr16})$	x		
	A, [HL]	1	6	$A \leftarrow A \oplus (\text{HL})$	x		
	A, [HL + byte]	2	6	$A \leftarrow A \oplus (\text{HL} + \text{byte})$	x		

Remark One instruction clock cycle is one CPU clock cycle (f_{CPU}) selected by the processor clock control register (PCC).

Mnemonic	Operand	Bytes	Clocks	Operation	Flag		
					Z	AC	CY
CMP	A, #byte	2	4	A – byte	x	x	x
	saddr, #byte	3	6	(saddr) – byte	x	x	x
	A, r	2	4	A – r	x	x	x
	A, saddr	2	4	A – (saddr)	x	x	x
	A, !addr16	3	8	A – (addr16)	x	x	x
	A, [HL]	1	6	A – (HL)	x	x	x
	A, [HL + byte]	2	6	A – (HL + byte)	x	x	x
ADDW	AX, #word	3	6	AX, CY ← AX + word	x	x	x
SUBW	AX, #word	3	6	AX, CY ← AX – word	x	x	x
CMPW	AX, #word	3	6	AX – word	x	x	x
INC	r	2	4	r ← r + 1	x	x	
	saddr	2	4	(saddr) ← (saddr) + 1	x	x	
DEC	r	2	4	r ← r – 1	x	x	
	saddr	2	4	(saddr) ← (saddr) – 1	x	x	
INCW	rp	1	4	rp ← rp + 1			
DECW	rp	1	4	rp ← rp – 1			
ROR	A, 1	1	2	(CY, A ₇ ← A ₀ , A _{m-1} ← A _m) × 1			x
ROL	A, 1	1	2	(CY, A ₀ ← A ₇ , A _{m+1} ← A _m) × 1			x
RORC	A, 1	1	2	(CY ← A ₀ , A ₇ ← CY, A _{m-1} ← A _m) × 1			x
ROLC	A, 1	1	2	(CY ← A ₇ , A ₀ ← CY, A _{m+1} ← A _m) × 1			x
SET1	saddr.bit	3	6	(saddr.bit) ← 1			
	sfr.bit	3	6	sfr.bit ← 1			
	A.bit	2	4	A.bit ← 1			
	PSW.bit	3	6	PSW.bit ← 1	x	x	x
	[HL].bit	2	10	(HL).bit ← 1			
CLR1	saddr.bit	3	6	(saddr.bit) ← 0			
	sfr.bit	3	6	sfr.bit ← 0			
	A.bit	2	4	A.bit ← 0			
	PSW.bit	3	6	PSW.bit ← 0	x	x	x
	[HL].bit	2	10	(HL).bit ← 0			
SET1	CY	1	2	CY ← 1			1
CLR1	CY	1	2	CY ← 0			0
NOT1	CY	1	2	CY ← $\overline{\text{CY}}$			x

Remark One instruction clock cycle is one CPU clock cycle (f_{CPU}) selected by the processor clock control register (PCC).

Mnemonic	Operand	Bytes	Clocks	Operation	Flag		
					Z	AC	CY
CALL	!addr16	3	6	$(SP - 1) \leftarrow (PC + 3)_H, (SP - 2) \leftarrow (PC + 3)_L,$ $PC \leftarrow \text{addr16}, SP \leftarrow SP - 2$			
CALLT	[addr5]	1	8	$(SP - 1) \leftarrow (PC + 1)_H, (SP - 2) \leftarrow (PC + 1)_L,$ $PC_H \leftarrow (00000000, \text{addr5} + 1),$ $PC_L \leftarrow (00000000, \text{addr5}), SP \leftarrow SP - 2$			
RET		1	6	$PC_H \leftarrow (SP + 1), PC_L \leftarrow (SP), SP \leftarrow SP + 2$			
RETI		1	8	$PC_H \leftarrow (SP + 1), PC_L \leftarrow (SP),$ $PSW \leftarrow (SP + 2), SP \leftarrow SP + 3, NMIS \leftarrow 0$	R	R	R
PUSH	PSW	1	2	$(SP - 1) \leftarrow PSW, SP \leftarrow SP - 1$			
	rp	1	4	$(SP - 1) \leftarrow rp_H, (SP - 2) \leftarrow rp_L, SP \leftarrow SP - 2$			
POP	PSW	1	4	$PSW \leftarrow (SP), SP \leftarrow SP + 1$	R	R	R
	rp	1	6	$rp_H \leftarrow (SP + 1), rp_L \leftarrow (SP), SP \leftarrow SP + 2$			
MOVW	SP, AX	2	8	$SP \leftarrow AX$			
	AX, SP	2	6	$AX \leftarrow SP$			
BR	!addr16	3	6	$PC \leftarrow \text{addr16}$			
	\$addr16	2	6	$PC \leftarrow PC + 2 + \text{jdisp8}$			
	AX	1	6	$PC_H \leftarrow A, PC_L \leftarrow X$			
BC	\$saddr16	2	6	$PC \leftarrow PC + 2 + \text{jdisp8}$ if CY = 1			
BNC	\$saddr16	2	6	$PC \leftarrow PC + 2 + \text{jdisp8}$ if CY = 0			
BZ	\$saddr16	2	6	$PC \leftarrow PC + 2 + \text{jdisp8}$ if Z = 1			
BNZ	\$saddr16	2	6	$PC \leftarrow PC + 2 + \text{jdisp8}$ if Z = 0			
BT	saddr.bit, \$saddr16	4	10	$PC \leftarrow PC + 4 + \text{jdisp8}$ if (saddr.bit) = 1			
	sfr.bit, \$saddr16	4	10	$PC \leftarrow PC + 4 + \text{jdisp8}$ if sfr.bit = 1			
	A.bit, \$saddr16	3	8	$PC \leftarrow PC + 3 + \text{jdisp8}$ if A.bit = 1			
	PSW.bit, \$saddr16	4	10	$PC \leftarrow PC + 4 + \text{jdisp8}$ if PSW.bit = 1			
BF	saddr.bit, \$saddr16	4	10	$PC \leftarrow PC + 4 + \text{jdisp8}$ if (saddr.bit) = 0			
	sfr.bit, \$saddr16	4	10	$PC \leftarrow PC + 4 + \text{jdisp8}$ if sfr.bit = 0			
	A.bit, \$saddr16	3	8	$PC \leftarrow PC + 3 + \text{jdisp8}$ if A.bit = 0			
	PSW.bit, \$saddr16	4	10	$PC \leftarrow PC + 4 + \text{jdisp8}$ if PSW.bit = 0			
DBNZ	B, \$saddr16	2	6	$B \leftarrow B - 1, \text{ then } PC \leftarrow PC + 2 + \text{jdisp8}$ if $B \neq 0$			
	C, \$saddr16	2	6	$C \leftarrow C - 1, \text{ then } PC \leftarrow PC + 2 + \text{jdisp8}$ if $C \neq 0$			
	saddr, \$saddr16	3	8	$(\text{saddr}) \leftarrow (\text{saddr}) - 1, \text{ then}$ $PC \leftarrow PC + 3 + \text{jdisp8}$ if $(\text{saddr}) \neq 0$			
NOP		1	2	No Operation			
EI		3	6	$IE \leftarrow 1$ (Enable Interrupt)			
DI		3	6	$IE \leftarrow 0$ (Disable Interrupt)			
HALT		1	2	Set HALT Mode			
STOP		1	2	Set STOP Mode			

Remark One instruction clock cycle is one CPU clock cycle (f_{CPU}) selected by the processor clock control register (PCC).

19.3 Instructions Listed by Addressing Type

(1) 8-bit instructions

MOV, XCH, ADD, ADDC, SUB, SUBC, AND, OR, XOR, CMP, INC, DEC, ROR, ROL, RORC, ROLC, PUSH, POP, DBNZ

2nd Operand 1st Operand	#byte	A	r	sfr	saddr	!addr16	PSW	[DE]	[HL]	[HL + byte]	\$addr16	1	None
A	ADD ADDC SUB SUBC AND OR XOR CMP		MOV ^{Note} XCH ^{Note}	MOV XCH	MOV XCH ADD ADDC SUB SUBC AND OR XOR CMP	MOV XCH ADD ADDC SUB SUBC AND OR XOR CMP	MOV	MOV XCH	MOV XCH ADD ADDC SUB SUBC AND OR XOR CMP	MOV XCH ADD ADDC SUB SUBC AND OR XOR CMP		ROR ROL RORC ROLC	
r	MOV	MOV											INC DEC
B, C											DBNZ		
sfr	MOV	MOV											
saddr	MOV ADD ADDC SUB SUBC AND OR XOR CMP	MOV									DBNZ		INC DEC
!addr16		MOV											
PSW	MOV	MOV											PUSH POP
[DE]		MOV											
[HL]		MOV											
[HL + byte]		MOV											

Note Except r = A.

(2) 16-bit instructions

MOVW, XCHW, ADDW, SUBW, CMPW, PUSH, POP, INCW, DECW

2nd Operand \ 1st Operand	#word	AX	rp ^{Note}	saddrp	SP	None
AX	ADDW SUBW CMPW		MOVW XCHW	MOVW	MOVW	
rp	MOVW	MOVW ^{Note}				INCW DECW PUSH POP
saddrp		MOVW				
sp		MOVW				

Note Only when rp = BC, DE, or HL.

(3) Bit manipulation instructions

SET1, CLR1, NOT1, BT, BF

2nd Operand \ 1st Operand	\$addr16	None
A.bit	BT BF	SET1 CLR1
sfr.bit	BT BF	SET1 CLR1
saddr.bit	BT BF	SET1 CLR1
PSW.bit	BT BF	SET1 CLR1
[HL].bit		SET1 CLR1
CY		SET1 CLR1 NOT1

(4) Call instructions/branch instructions

CALL, CALLT, BR, BC, BNC, BZ, BNZ, DBNZ

2nd Operand \ 1st Operand	AX	!addr16	[addr5]	\$addr16
Basic instructions	BR	CALL BR	CALLT	BR BC BNC BZ BNZ
Compound instructions				DBNZ

(5) Other instructions

RET, RETI, NOP, EI, DI, HALT, STOP

CHAPTER 20 ELECTRICAL SPECIFICATIONS

Absolute Maximum Ratings ($T_A = 25^\circ\text{C}$)

Parameter	Symbol	Conditions	Ratings	Unit
Supply voltage	V_{DD}		-0.3 to +6.5	V
	V_{PP}	$\mu\text{PD78E9860A}$, 78E9861A only, Note	-0.3 to +10.5	V
Input voltage	V_I		-0.3 to $V_{DD} + 0.3$	V
Output voltage	V_O		-0.3 to $V_{DD} + 0.3$	V
Output current, high	I_{OH}	Per pin	-10	mA
		Total of all pins	-30	mA
Output current, low	I_{OL}	Per pin	30	mA
		Total of all pins	80	mA
Operating ambient temperature	T_A		-40 to +85	$^\circ\text{C}$
Storage temperature	T_{stg}	Mask ROM version	-65 to +150	$^\circ\text{C}$
		EEPROM version	-40 to +125	$^\circ\text{C}$

Note Make sure that the following conditions of the V_{PP} voltage application timing are satisfied when the EEPROM (program memory) is written.

- When supply voltage rises
 V_{PP} must exceed V_{DD} 10 μs or more after V_{DD} has reached the lower-limit value (1.8 V) of the operating voltage range (see a in the figure below).
- When supply voltage drops
 V_{DD} must be lowered 10 μs or more after V_{PP} falls below the lower-limit value (1.8 V) of the operating voltage range of V_{DD} (see b in the figure below).

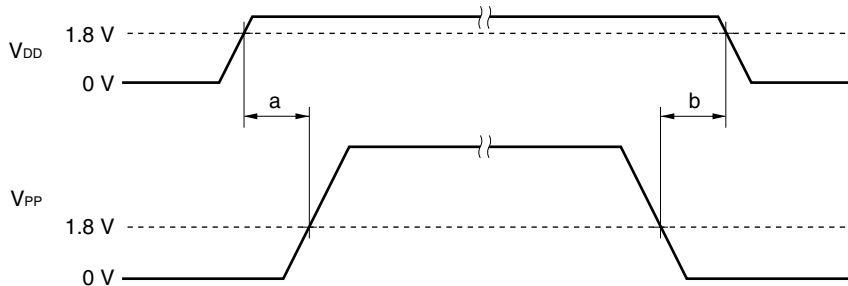

Caution Product quality may suffer if the absolute maximum rating is exceeded even momentarily for any parameter. That is, the absolute maximum rating are rated values at which the product is on the verge of suffering physical damage, and therefore the product must be used under conditions the ensure that the absolute maximum ratings are not exceeded.

Remark Unless specified otherwise, the characteristics of alternate-function pins are the same as those of port pins.

System Clock Oscillator Characteristics

Ceramic or crystal oscillation (μ PD789052, 78E9860A)

($T_A = -40$ to $+85^\circ\text{C}$, $V_{DD} = 1.8$ to 5.5 V)

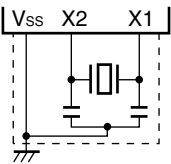
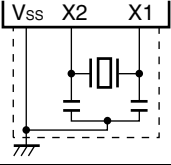
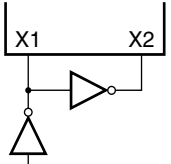
Resonator	Recommended Circuit	Parameter	Conditions	MIN.	TYP.	MAX.	Unit
Ceramic resonator		Oscillation frequency (f_x) ^{Note 1}	$V_{DD} =$ Oscillation voltage range	1.0		5.0	MHz
		Oscillation stabilization time ^{Note 2}	After V_{DD} reaches oscillation voltage range MIN.			4	ms
Crystal resonator		Oscillation frequency (f_x) ^{Note 1}		1.0		5.0	MHz
		Oscillation stabilization time ^{Note 2}				30	ms
External clock		X1 input frequency (f_x) ^{Note 1}		1.0		5.0	MHz
		X1 input high-/low-level width (t_{xH} , t_{xL})		85		500	ns

- Notes**
1. Indicates only oscillator characteristics. Refer to **AC Characteristics** for instruction execution time.
 2. Time required to stabilize oscillation after reset or STOP mode release.

Caution When using a ceramic or crystal oscillator, wire as follows in the area enclosed by the broken lines in the above figures to avoid an adverse effect from wiring capacitance.

- Keep the wiring length as short as possible.
- Do not cross with other signal lines.
- Do not route the wiring near a signal line through which a high fluctuating current flows.
- Always make the ground point of the oscillator capacitor the same potential as V_{SS} .
- Do not ground the capacitor to a ground pattern through which a high current flows.
- Do not fetch signals from the oscillator.

Recommended Oscillation Circuit Constants

Ceramic oscillator (T_A = -40 to +85°C) (μPD789052)

Manufacturer	Part Number	Frequency (MHz)	Recommended Circuit Constant (pF)		Oscillation Voltage Range (V _{DD})		Remark
			C1	C2	MIN.	MAX.	
Murata Mfg.	CSBLA1M00J58-B0 ^{Note}	1.0	100	100	2.0	5.5	Rd = 1.0 kΩ
	CSTCC2M00G56-R0	2.0	-	-	1.8	5.5	With internal capacitor
	CSTCR4M00G53-R0	4.0					
	CSTLS4M00G53-B0	4.194					
	CSTCR4M19G53-R0						
	CSTLS4M19G53-B0						
	CSTCR4M91G53-R0	4.915					
	CSTLS4M91G53-B0						
	CSTCR5M00G53-R0	5.0					
	CSTLS5M00G53-B0						

Note When using the CSBLA1M00J58-B0 (1.0 MHz) of Murata Mfg. as the ceramic oscillator, a limiting resistor (Rd = 1.0 kΩ) is necessary (refer to the figure below). The limiting resistor is not necessary when other recommended oscillators are used.

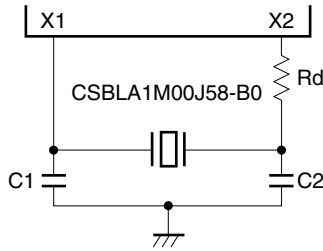

Caution The oscillator constant is a reference value based on evaluation under a specific environment by the resonator manufacturer.

If optimization of oscillator characteristics is necessary in the actual application, apply to the resonator manufacturer for evaluation on the implementation circuit.

The oscillation voltage and oscillation frequency indicate only oscillator characteristics. Use the μPD789052 so that the internal operating conditions are within the specifications of the DC and AC characteristics.

Remark For the resonator selection and oscillator constant of the μPD78E9860A, customers are required to either evaluate the oscillation themselves or apply to the resonator manufacturer for evaluation.

RC oscillation (μ PD789062, 78E9861A)

($T_A = -40$ to $+85^\circ\text{C}$, $V_{DD} = 1.8$ to 3.6 V)

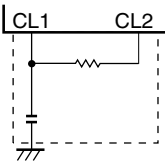
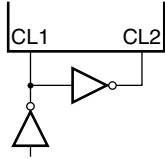
Resonator	Recommended Circuit	Parameter	Conditions	MIN.	TYP.	MAX.	Unit
RC oscillator		Oscillation frequency (f_{CC}) ^{Notes 1,2}	$V_{DD} =$ Oscillation voltage range	0.85		1.15	MHz
External clock		CL1 input frequency (f_{CC}) ^{Note 1}		1.0		5.0	MHz
		CL1 input high-/low-level width (t_{XH} , t_{XL})		85		500	ns

- Notes**
1. Indicates only oscillator characteristics. Refer to **AC Characteristics** for instruction execution time.
 2. Variations due to external resistance and external capacitance are not included.

Caution When using an RC oscillator, wire as follows in the area enclosed by the broken lines in the above figure to avoid an adverse effect from wiring capacitance.

- Keep the wiring length as short as possible.
- Do not cross with other signal lines.
- Do not route the wiring near a signal line through which a high fluctuating current flows.
- Always make the ground point of the oscillator capacitor the same potential as V_{SS} .
- Do not ground the capacitor to a ground pattern through which a high current flows.
- Do not fetch signals from the oscillator.

DC Characteristics (μ PD789052, 78E9860A) ($T_A = -40$ to $+85^\circ\text{C}$, $V_{DD} = 1.8$ to 5.5 V)

Parameter	Symbol	Conditions		MIN.	TYP.	MAX.	Unit
Output current, low	I_{OL}	μ PD789052	Per pin			10	mA
			All pins			40	mA
		μ PD78E9860A	Per pin			3	mA
			All pins			7.5	mA
Output current, high	I_{OH}	μ PD789052	Per pin			-1	mA
			All pins			-15	mA
		μ PD78E9860A	Per pin			-0.75	mA
			All pins			-7.5	mA
Input voltage, high	V_{IH1}	P00 to P07	$2.7 \text{ V} \leq V_{DD} \leq 5.5 \text{ V}$	$0.7V_{DD}$		V_{DD}	V
			$1.8 \text{ V} \leq V_{DD} < 2.7 \text{ V}$	$0.9V_{DD}$		V_{DD}	V
	V_{IH2}	RESET, P20, P21, P40 to P43	$2.7 \text{ V} \leq V_{DD} \leq 5.5 \text{ V}$	$0.8V_{DD}$		V_{DD}	V
			$1.8 \text{ V} \leq V_{DD} < 2.7 \text{ V}$	$0.9V_{DD}$		V_{DD}	V
	V_{IH3}	X1, X2		$V_{DD} - 0.1$		V_{DD}	V
	Input voltage, low	V_{IL1}	P00 to P07	$2.7 \text{ V} \leq V_{DD} \leq 5.5 \text{ V}$	0		$0.3V_{DD}$
$1.8 \text{ V} \leq V_{DD} < 2.7 \text{ V}$				0		$0.1V_{DD}$	V
V_{IL2}		RESET, P20, P21, P40 to P43	$2.7 \text{ V} \leq V_{DD} \leq 5.5 \text{ V}$	0		$0.2V_{DD}$	V
			$1.8 \text{ V} \leq V_{DD} < 2.7 \text{ V}$	0		$0.1V_{DD}$	V
V_{IL3}		X1, X2		0		0.1	V
Output voltage, high		V_{OH1}	P00 to P07, P20, P21	$I_{OH} = -100 \mu\text{A}$	$V_{DD} - 0.5$		
	V_{OH2}	$I_{OH} = -500 \mu\text{A}$		$V_{DD} - 0.7$			V
Output voltage, low	V_{OL1}	P00 to P07, P20, P21	$I_{OL} = 400 \mu\text{A}$			0.5	V
	V_{OL2}		$I_{OL} = 2 \text{ mA}$			0.7	V
Input leakage current, high	I_{LIH1}	$V_I = V_{DD}$	P00 to P07, P20, P21, P40 to P43, RESET	μ PD789052		1	μA
				μ PD78E9860A		3	μA
	I_{LIH2}	X1, X2				20	μA
Input leakage current, low	I_{LIL1}	$V_I = 0 \text{ V}$	P00 to P07, P20, P21, P40 to P43, RESET	μ PD789052		-1	μA
				μ PD78E9860A		-3	μA
	I_{LIL2}	X1, X2				-20	μA
Output leakage current, high	I_{LOH}	$V_O = V_{DD}$	μ PD789052			1	μA
			μ PD78E9860A			3	μA
Output leakage current, low	I_{LOL}	$V_O = 0 \text{ V}$	μ PD789052			-1	μA
			μ PD78E9860A			-3	μA
Mask-option pull-up resistor	R	$V_{IN} = 0 \text{ V}$, P40 to P43, μ PD789052 only		50	100	200	k Ω

Remark Unless specified otherwise, the characteristics of alternate-function pins are the same as those of port pins.

DC Characteristics (μ PD789062, 78E9861A) ($T_A = -40$ to $+85^\circ\text{C}$, $V_{DD} = 1.8$ to 3.6 V)

Parameter	Symbol	Conditions		MIN.	TYP.	MAX.	Unit
Output current, low	I_{OL}	μ PD789062	Per pin			10	mA
			All pins			40	mA
		μ PD78E9861A	Per pin			2	mA
			All pins			5.0	mA
Output current, high	I_{OH}	μ PD789062	Per pin			-1	mA
			All pins			-15	mA
		μ PD78E9861A	Per pin			-0.5	mA
			All pins			-5.0	mA
Input voltage, high	V_{IH1}	P00 to P07	$2.7\text{ V} \leq V_{DD} \leq 3.6\text{ V}$	$0.7V_{DD}$		V_{DD}	V
			$1.8\text{ V} \leq V_{DD} < 2.7\text{ V}$	$0.9V_{DD}$		V_{DD}	V
	V_{IH2}	RESET, P20, P21, P40 to P43	$2.7\text{ V} \leq V_{DD} \leq 3.6\text{ V}$	$0.8V_{DD}$		V_{DD}	V
			$1.8\text{ V} \leq V_{DD} < 2.7\text{ V}$	$0.9V_{DD}$		V_{DD}	V
	V_{IH3}	CL1, CL2		$V_{DD} - 0.1$		V_{DD}	V
	Input voltage, low	V_{IL1}	P00 to P07	$2.7\text{ V} \leq V_{DD} \leq 3.6\text{ V}$	0		$0.3V_{DD}$
$1.8\text{ V} \leq V_{DD} < 2.7\text{ V}$				0		$0.1V_{DD}$	V
V_{IL2}		RESET, P20, P21, P40 to P43	$2.7\text{ V} \leq V_{DD} \leq 3.6\text{ V}$	0		$0.2V_{DD}$	V
			$1.8\text{ V} \leq V_{DD} < 2.7\text{ V}$	0		$0.1V_{DD}$	V
V_{IL3}		CL1, CL2		0		0.1	V
Output voltage, high		V_{OH1}	P00 to P07, P20, P21	$I_{OH} = -100\ \mu\text{A}$	$V_{DD} - 0.5$		
	V_{OH2}	$I_{OH} = -500\ \mu\text{A}$		$V_{DD} - 0.7$			V
Output voltage, low	V_{OL1}	P00 to P07, P20, P21	$I_{OL} = 400\ \mu\text{A}$			0.5	V
	V_{OL2}		$I_{OL} = 2\text{ mA}$			0.7	V
Input leakage current, high	I_{LIH1}	$V_I = V_{DD}$	P00 to P07, P20, P21, P40 to P43, RESET	μ PD789062		1	μA
				μ PD78E9861A		3	μA
	I_{LIH2}	CL1, CL2				20	μA
Input leakage current, low	I_{LIL1}	$V_I = 0\text{ V}$	P00 to P07, P20, P21, P40 to P43, RESET	μ PD789062		-1	μA
				μ PD78E9861A		-3	μA
	I_{LIL2}	CL1, CL2				-20	μA
Output leakage current, high	I_{LOH}	$V_O = V_{DD}$	μ PD789062			1	μA
			μ PD78E9861A			3	μA
Output leakage current, low	I_{LOL}	$V_O = 0\text{ V}$	μ PD789062			-1	μA
			μ PD78E9861A			-3	μA
Mask-option pull-up resistor	R	$V_{IN} = 0\text{ V}$, P40 to P43, μ PD789062 only		50	100	200	k Ω

Remark Unless specified otherwise, the characteristics of alternate-function pins are the same as those of port pins.

DC Characteristics ($T_A = -40$ to $+85^\circ\text{C}$, $V_{DD} = 1.8$ to 5.5 V (for $\mu\text{PD789052}$), $V_{DD} = 1.8$ to 3.6 V (for $\mu\text{PD789062}$))

Parameter	Symbol	Conditions	MIN.	TYP.	MAX.	Unit	
Power supply current ^{Note} Ceramic/crystal oscillation: $\mu\text{PD789052}$	I_{DD1}	5.0 MHz Crystal oscillation operating mode $C_1 = C_2 = 22$ pF	$V_{DD} = 5.0$ V $\pm 10\%$		1.0	2.6	mA
			$V_{DD} = 3.0$ V $\pm 10\%$		0.5	1.0	mA
			$V_{DD} = 2.0$ V $\pm 10\%$		0.3	0.7	mA
	I_{DD2}	5.0 MHz Crystal oscillation HALT mode $C_1 = C_2 = 22$ pF	$V_{DD} = 5.0$ V $\pm 10\%$		0.6	1.8	mA
			$V_{DD} = 3.0$ V $\pm 10\%$		0.25	0.6	mA
			$V_{DD} = 2.0$ V $\pm 10\%$		0.22	0.5	mA
	I_{DD3}	STOP mode	$V_{DD} = 5.0$ V $\pm 10\%$		0.1	3.0	μA
			$V_{DD} = 3.0$ V $\pm 10\%$		0.05	0.9	μA
			$V_{DD} = 2.0$ V $\pm 10\%$		0.05	0.8	μA
Power supply current ^{Note} RC oscillation: $\mu\text{PD789062}$	I_{DD4}	1.0 MHz $\pm 15\%$ RC oscillation operating mode $R = 24$ k Ω , $C = 30$ pF	$V_{DD} = 3.0$ V $\pm 10\%$		0.3	0.8	mA
			$V_{DD} = 2.0$ V $\pm 10\%$		0.26	0.6	mA
	I_{DD5}	1.0 MHz $\pm 15\%$ RC oscillation HALT mode $R = 24$ k Ω , $C = 30$ pF	$V_{DD} = 3.0$ V $\pm 10\%$		0.25	0.6	mA
			$V_{DD} = 2.0$ V $\pm 10\%$		0.22	0.5	mA
	I_{DD6}	STOP mode	$V_{DD} = 3.0$ V $\pm 10\%$		0.05	0.9	μA
			$V_{DD} = 2.0$ V $\pm 10\%$		0.05	0.8	μA

Note Port current (including current flowing in on-chip pull-up resistors) is not included.

Remark Unless specified otherwise, the characteristics of alternate-function pins are the same as those of port pins.

DC Characteristics

($T_A = -40$ to $+85^\circ\text{C}$, $V_{DD} = 1.8$ to 5.5 V ($\mu\text{PD78E9860A}$), $V_{DD} = 1.8$ to 3.6 V ($\mu\text{PD78E9861A}$))

Parameter	Symbol	Conditions	MIN.	TYP.	MAX.	Unit	
★ Power supply current ^{Note} Ceramic/crystal oscillation: $\mu\text{PD78E9860A}$	I_{DD1}	5.0 MHz crystal oscillation operating mode (EEPROM halted) $C_1 = C_2 = 22$ pF	$V_{DD} = 5.0$ V $\pm 10\%$		2.5	5.0	mA
	I_{DD2}	5.0 MHz crystal oscillation operating mode (EEPROM operating) $C_1 = C_2 = 22$ pF	$V_{DD} = 5.0$ V $\pm 10\%$		3.0	6.0	mA
	I_{DD3}	5.0 MHz crystal oscillation HALT mode (EEPROM halted) $C_1 = C_2 = 22$ pF	$V_{DD} = 5.0$ V $\pm 10\%$		1.6	3.2	mA
	I_{DD4}	STOP mode (POC operating)	$V_{DD} = 5.0$ V $T_A = -40$ to $+85^\circ\text{C}$		1.2	4.0	μA
			$V_{DD} = 3.0$ V $\pm 10\%$ $T_A = -40$ to $+85^\circ\text{C}$		1.0	2.5	μA
			$V_{DD} = 5.0$ V $T_A = -20$ to $+75^\circ\text{C}$			3.0	μA
			$V_{DD} = 3.0$ V $\pm 10\%$ $T_A = -20$ to $+75^\circ\text{C}$		1.0	2.0	μA
	I_{DD5}	STOP mode (POC operation halted)	$V_{DD} = 5.0$ V $T_A = -40$ to $+85^\circ\text{C}$			3.0	μA
			$V_{DD} = 3.0$ V $\pm 10\%$ $T_A = -40$ to $+85^\circ\text{C}$			1.5	μA
			$V_{DD} = 5.0$ V $T_A = 25^\circ\text{C}$			0.9	μA
★ Power supply current ^{Note} RC oscillation: $\mu\text{PD78E9861A}$	I_{DD1}	1.0 MHz RC oscillation operating mode (EEPROM halted) $R = 24$ k Ω , $C = 30$ pF	$V_{DD} = 3.0$ V $\pm 10\%$		0.8	1.6	mA
	I_{DD2}	1.0 MHz RC oscillation operating mode (EEPROM operating) $R = 24$ k Ω , $C = 30$ pF	$V_{DD} = 3.0$ V $\pm 10\%$		1.0	2.0	mA
	I_{DD3}	1.0 MHz RC oscillation HALT mode (EEPROM halted) $R = 24$ k Ω , $C = 30$ pF	$V_{DD} = 3.0$ V $\pm 10\%$		0.7	1.4	mA
	I_{DD4}	STOP mode (POC operating)	$V_{DD} = 3.0$ V $\pm 10\%$ $T_A = -40$ to $+85^\circ\text{C}$		1.0	2.5	μA
			$V_{DD} = 3.0$ V $\pm 10\%$ $T_A = -20$ to $+75^\circ\text{C}$		1.0	2.0	μA
	I_{DD5}	STOP mode (POC operation halted)	$V_{DD} = 3.0$ V $\pm 10\%$			1.5	μA

Note Port current (including current flowing in on-chip pull-up resistors) is not included. This current will be further added to when writing to or reading from EEPROM (data memory). For the specific current values, refer to **EEPROM (Data Memory) Characteristics**.

Remark Unless specified otherwise, the characteristics of alternate-function pins are the same as those of port pins.

AC Characteristics

(1) μ PD789052, 78E9860A ($T_A = -40$ to $+85^\circ\text{C}$, $V_{DD} = 1.8$ to 5.5 V)

Parameter	Symbol	Conditions	MIN.	TYP.	MAX.	Unit
Cycle time (minimum instruction execution time) Ceramic/crystal oscillation	T_{CY}	$2.7\text{ V} \leq V_{DD} \leq 5.5\text{ V}$	0.4		8	μs
		$1.8\text{ V} \leq V_{DD} < 2.7\text{ V}$	1.6		8	μs
TMI input input frequency	f_{TI}	$2.7\text{ V} \leq V_{DD} \leq 5.5\text{ V}$	0		4.0	MHz
		$1.8\text{ V} \leq V_{DD} < 2.7\text{ V}$	0		500	kHz
TMI high-/low-level width	t_{TIH} , t_{TIL}	$2.7\text{ V} \leq V_{DD} \leq 5.5\text{ V}$	0.1			μs
		$1.8\text{ V} \leq V_{DD} < 2.7\text{ V}$	1.0			μs
Key return input pin low-level width	t_{KRIL}	KR10 to KR13	10			μs
$\overline{\text{RESET}}$ low-level width	t_{RSL}		10			μs

T_{CY} vs. V_{DD} (System Clock: Ceramic/Crystal Oscillation)

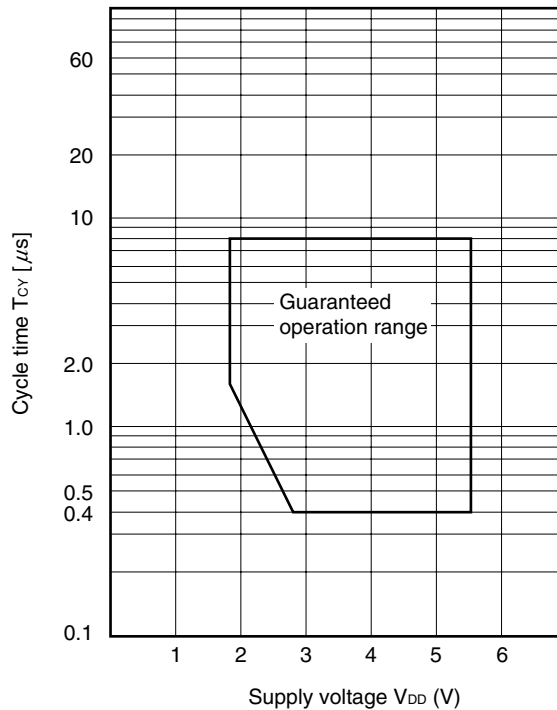

(2) μ PD789062, 78E9861A ($T_A = -40$ to $+85^\circ\text{C}$, $V_{DD} = 1.8$ to 3.6 V)

Parameter	Symbol	Conditions	MIN.	TYP.	MAX.	Unit
Cycle time (minimum instruction execution time) RC oscillation	T_{CY}	$2.7\text{ V} \leq V_{DD} \leq 3.6\text{ V}$	0.4		9.42	μs
		$1.8\text{ V} \leq V_{DD} < 2.7\text{ V}$	1.6		9.42	μs
TMI input input frequency	f_{TI}	$2.7\text{ V} \leq V_{DD} \leq 3.6\text{ V}$	0		4.0	MHz
		$1.8\text{ V} \leq V_{DD} < 2.7\text{ V}$	0		500	kHz
TMI high-/low-level width	t_{TIH} , t_{TIL}	$2.7\text{ V} \leq V_{DD} \leq 3.6\text{ V}$	0.1			μs
		$1.8\text{ V} \leq V_{DD} < 2.7\text{ V}$	1.0			μs
Key return input pin low-level width	t_{KRIL}	KR10 to KR13	10			μs
$\overline{\text{RESET}}$ low-level width	t_{RSL}		10			μs

T_{CY} vs. V_{DD} (System Clock: RC Oscillation)

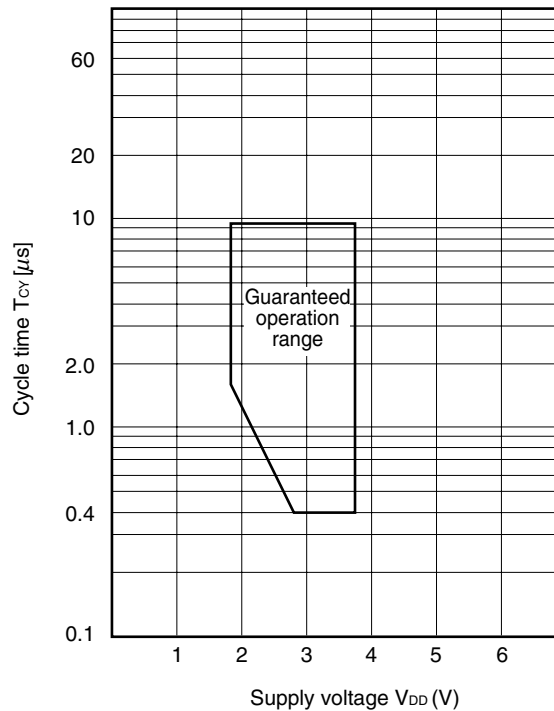

(3) RC oscillation frequency characteristics ($T_A = -40$ to $+85^\circ\text{C}$, $V_{DD} = 1.8$ to 3.6 V) (μ PD789062, 78E9861A only)

Parameter	Symbol	Conditions	MIN.	TYP.	MAX.	Unit
Oscillation frequency ^{Note}	f_{CC}	$R = 24\text{ k}\Omega$, $C = 30\text{ pF}$	0.85	1.00	1.15	MHz

Note Variations due to external resistance and external capacitance are not included.

AC Timing Measurement Points (Excluding X1, CL1 Input)

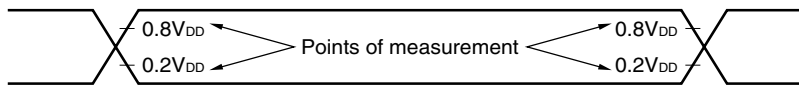

Clock Timing

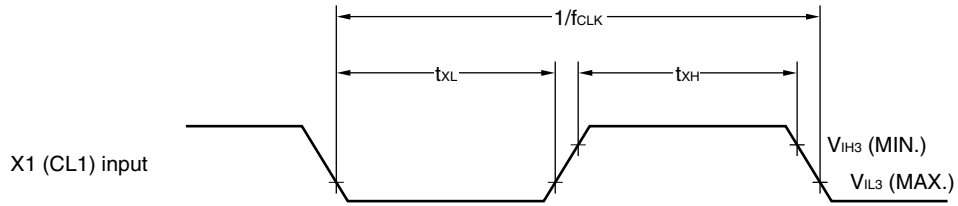

Remark f_{CLK} : fx or fcc

TMI Timing

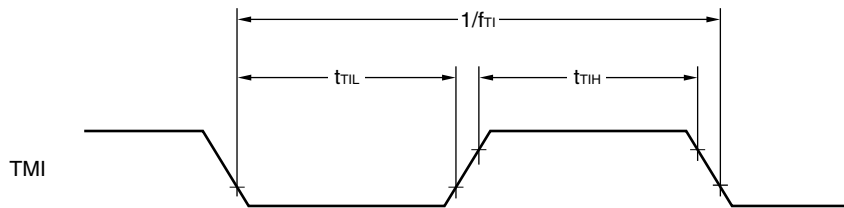

Key Return Input Timing

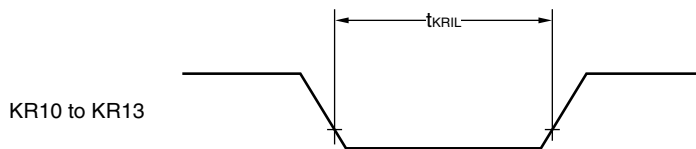

RESET Input Timing

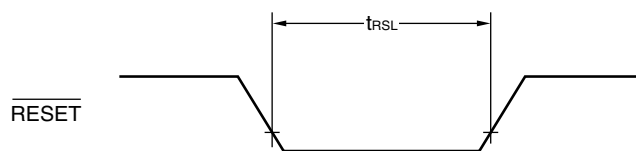

Power-on-Clear Circuit Characteristics (μ PD78E9860A, 78E9861A only)

(1) POC

(a) DC characteristics ($T_A = -40$ to $+85^\circ\text{C}$, $V_{DD} = 1.8$ to 5.5 V (μ PD78E9860A), $V_{DD} = 1.8$ to 3.6 V (μ PD78E9861A))

Parameter	Symbol	Conditions	MIN.	TYP.	MAX.	Unit
Detection voltage	V_{POC}	Response time ^{Note 1} : 2 ms	1.8 ^{Note 2}	1.9 ^{Note 2}	2.0	V

- Notes**
1. Time from detecting voltage until output reverses and time until stable operation after transition from halted state to operating state.
 2. Note that the POC detection voltage may be lower than the operating voltage range of these products.

(b) AC characteristics ($T_A = -40$ to $+85^\circ\text{C}$)

Parameter	Symbol	Conditions	MIN.	TYP.	MAX.	Unit
Power rise time	T_{Pth1}	$V_{DD}: 0 \rightarrow 1.8$ V	0.01		100	ms
	T_{Pth2}	$V_{DD}: 0 \rightarrow 1.8$ V $T_A = +25^\circ\text{C}$	10			μs

(2) LVI

(a) DC characteristics ($T_A = -40$ to $+85^\circ\text{C}$, $V_{DD} = 1.8$ to 5.5 V (μ PD78E9860A), $V_{DD} = 1.8$ to 3.6 V (μ PD78E9861A))

Parameter	Symbol	Conditions	MIN.	TYP.	MAX.	Unit
LVI7 detection voltage	V_{LVI7}	Response time ^{Note 1} : 2 ms	2.4	2.6	2.8	V
LVI6 detection voltage	V_{LVI6}	Response time ^{Note 1} : 2 ms		Note 2		V
LVI5 detection voltage	V_{LVI5}	Response time ^{Note 1} : 2 ms		Note 2		V
LVI4 detection voltage	V_{LVI4}	Response time ^{Note 1} : 2 ms		Note 2		V
LVI3 detection voltage	V_{LVI3}	Response time ^{Note 1} : 2 ms		Note 2		V
LVI2 detection voltage	V_{LVI2}	Response time ^{Note 1} : 2 ms		Note 2		V
LVI1 detection voltage	V_{LVI1}	Response time ^{Note 1} : 2 ms		Note 2		V
LVI0 detection voltage	V_{LVI0}	Response time ^{Note 1} : 2 ms	Note 3	2.0	2.2	V

- Notes**
1. Time from detecting voltage until output reverses and time until stable operation after transition from halted state to operating state
 2. Relative relationship: $V_{LVI7} > V_{LVI6} > V_{LVI5} > V_{LVI4} > V_{LVI3} > V_{LVI2} > V_{LVI1} > V_{LVI0}$
 3. $V_{POC} < V_{LVI0}$

EEPROM (Data Memory) Characteristics (T_A = -40 to +85°C, V_{DD} = 1.8 to 5.5 V (μPD78E9860A), V_{DD} = 1.8 to 3.6 V (μPD78E9861A))

Parameter	Symbol	Conditions	MIN.	TYP.	MAX.	Unit
Write time ^{Note 1}			3.3		6.6	ms
Number of overwrites		Per 32 bytes			10	10,000 times
		Per 4 KB			100	times

Note Write time = T × 145 (T = time of 1 clock cycle selected by EWCS100 to EWCS102)

Data Memory STOP Mode Low Supply Voltage Data Retention Characteristics (T_A = -40 to +85°C)

Parameter	Symbol	Conditions	MIN.	TYP.	MAX.	Unit
Data retention power supply voltage	V _{DDDR}	μPD789052, 78E9860A	1.8		5.5	V
		μPD789062, 78E9861A	1.8		3.6	V
Release signal set time	t _{SREL}	STOP release by $\overline{\text{RESET}}$ pin	10			μs

Data Retention Timing

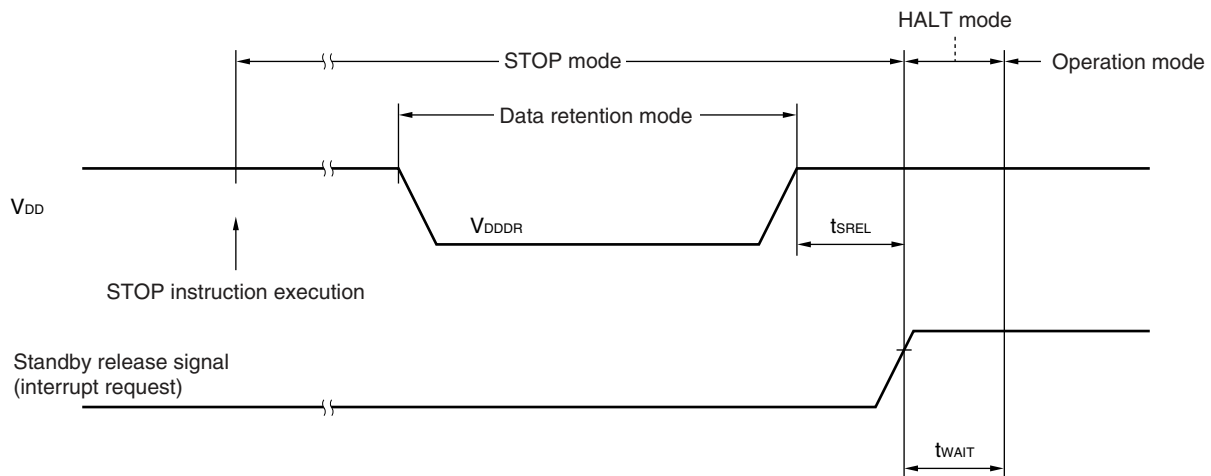
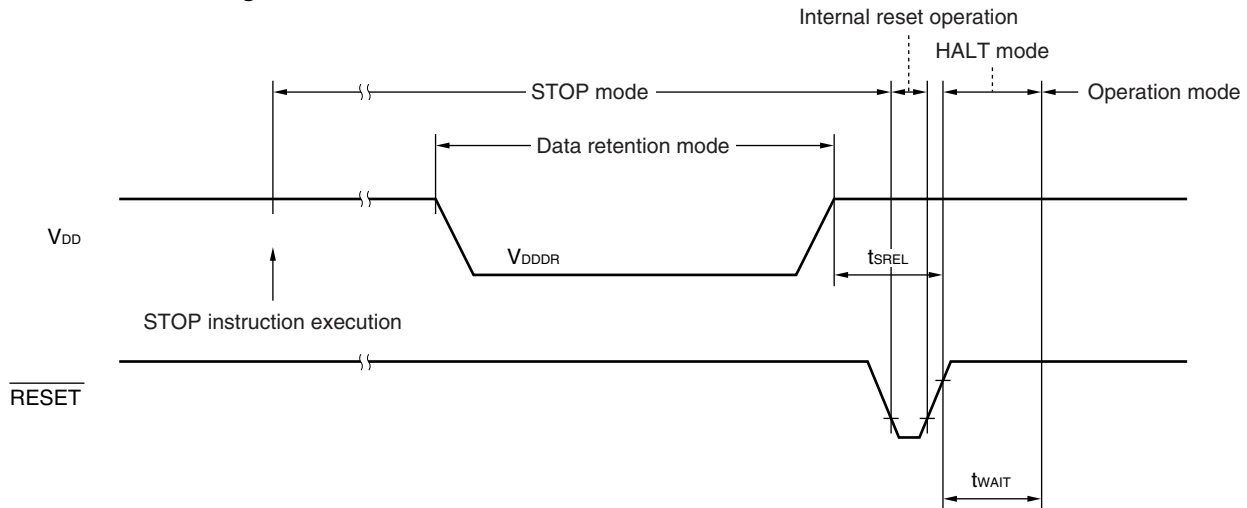

Oscillation Stabilization Wait Time

(a) Ceramic/crystal oscillation ($T_A = -40$ to 85°C , $V_{DD} = 1.8$ to 5.5 V) ($\mu\text{PD789052}$, 78E9860A)

Parameter	Symbol	Conditions	MIN.	TYP.	MAX.	Unit
Oscillation wait time ^{Note 1}	t_{WAIT}	STOP release by $\overline{\text{RESET}}$ or reset release by POC		$2^{15}/f_x$		s
		Release by interrupt		Note 2		s

Notes 1. Time required to stabilize oscillation after a reset or STOP mode release.

2. $2^{12}/f_x$, $2^{15}/f_x$, or $2^{17}/f_x$ can be selected using bits 0 to 2 of the oscillation stabilization time selection register (OSTS0 to OSTS2).

(b) RC oscillation ($T_A = -40$ to $+85^\circ\text{C}$, $V_{DD} = 1.8$ to 3.6 V) ($\mu\text{PD789062}$, 78E9861A)

Parameter	Symbol	Conditions	MIN.	TYP.	MAX.	Unit
Oscillation wait time ^{Note}	t_{WAIT}	STOP release by $\overline{\text{RESET}}$ or reset release by POC		$2^7/f_{cc}$		s
		Release by interrupt		$2^7/f_{cc}$		s

Note Time required to stabilize oscillation after a reset or STOP mode release.

CHAPTER 21 EXAMPLE OF RC OSCILLATION FREQUENCY CHARACTERISTICS (REFERENCE VALUES)

f_{cc} vs. V_{DD} (RC Oscillation: μ PD789062, $R = 24\text{ k}\Omega$, $C = 30\text{ pF}$)

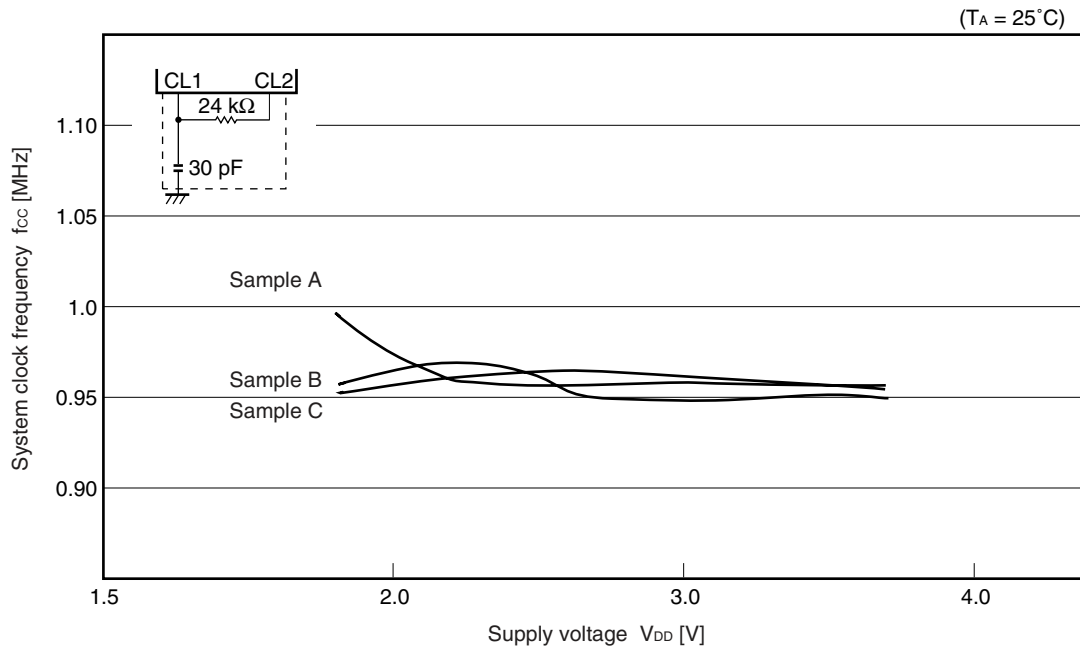

CHAPTER 22 PACKAGE DRAWING

20-PIN PLASTIC SSOP (7.62 mm (300))

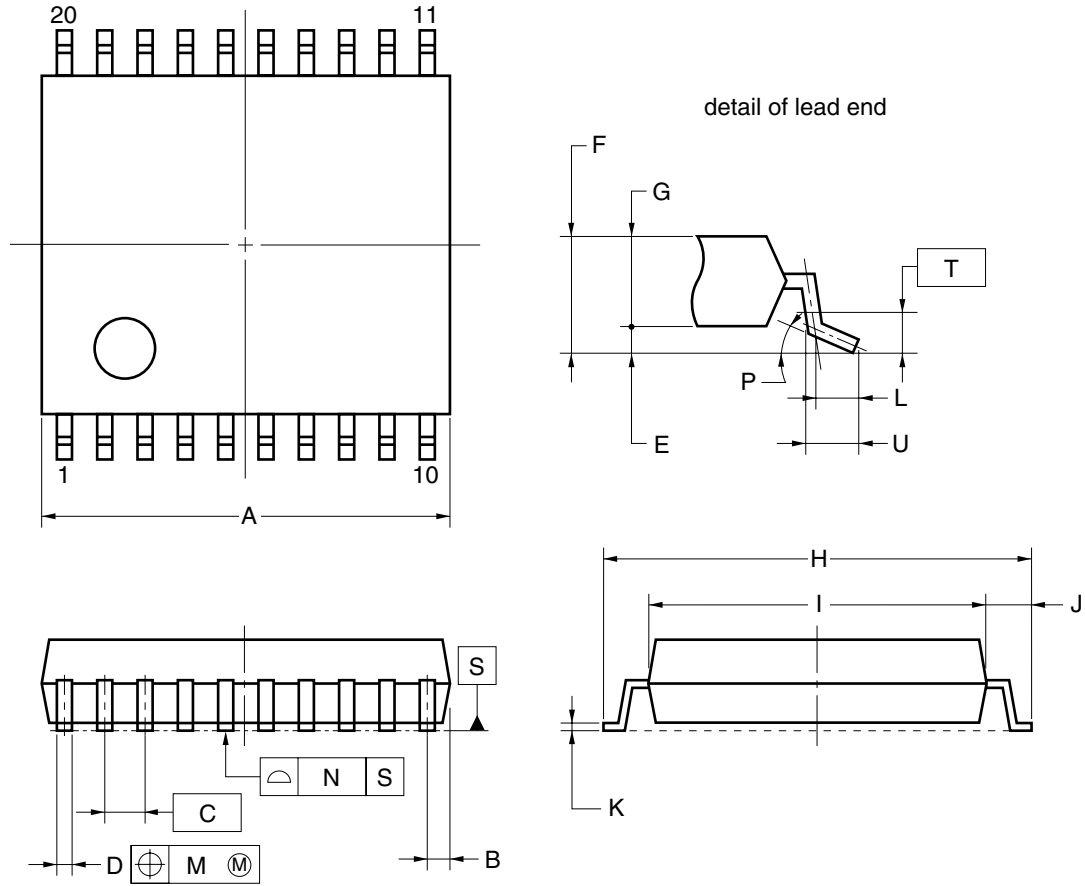

NOTE

Each lead centerline is located within 0.13 mm of its true position (T.P.) at maximum material condition.

ITEM	MILLIMETERS
A	6.65±0.15
B	0.475 MAX.
C	0.65 (T.P.)
D	0.24 ^{+0.08} _{-0.07}
E	0.1±0.05
F	1.3±0.1
G	1.2
H	8.1±0.2
I	6.1±0.2
J	1.0±0.2
K	0.17±0.03
L	0.5
M	0.13
N	0.10
P	3° ^{+5°} _{-3°}
T	0.25
U	0.6±0.15

S20MC-65-5A4-2

CHAPTER 23 RECOMMENDED SOLDERING CONDITIONS

The μ PD789052, 789062, 78E9860A, and 78E9861A should be soldered and mounted under the following recommended conditions.

For soldering methods and conditions other than those recommended below, contact an NEC Electronics sales representative.

For technical information, see the following website.

Semiconductor Device Mount Manual (<http://www.necel.com/pkg/en/mount/index/html>)

★ **Table 23-1. Surface Mounting Type Soldering Conditions (1/2)**

μ PD789052MC-xxx-5A4: 20-pin plastic SSOP (7.62 mm (300))

μ PD789062MC-xxx-5A4: 20-pin plastic SSOP (7.62 mm (300))

Soldering Method	Soldering Conditions	Recommended Condition Symbol
Infrared reflow	Package peak temperature: 235°C, Time: 30 seconds max. (at 210°C or higher), Count: three times or less	IR35-00-3
VPS	Package peak temperature: 215°C, Time: 40 seconds max. (at 200°C or higher), Count: three times or less	VP15-00-3
Wave soldering	Solder bath temperature: 260°C max., Time: 10 seconds max., Count: Once, Preheating temperature: 120°C max. (package surface temperature)	WS60-00-1
Partial heating	Pin temperature: 350°C max. Time: 3 seconds max. (per pin row)	–

Note After opening the dry pack, store it at 25°C or less and 65% RH or less for the allowable storage period.

Caution Do not use different soldering method together (except for partial heating).

Table 23-1. Surface Mounting Type Soldering Conditions (2/2)

μPD78E9860AMC-5A4: 20-pin plastic SSOP (7.62 mm (300))

μPD78E9861AMC-5A4: 20-pin plastic SSOP (7.62 mm (300))

Soldering Method	Soldering Conditions	Recommended Condition Symbol
Infrared reflow	Package peak temperature: 235°C, Time: 30 seconds max. (at 210°C or higher), Count: Two times or less, Exposure limit: 3 days ^{Note} (after that, prebake at 125°C for 10 hours)	IR35-103-2
VPS	Package peak temperature: 215°C, Time: 40 seconds max. (at 200°C or higher), Count: Two times or less, Exposure limit: 3 days ^{Note} (after that, prebake at 125°C for 10 hours)	VP15-103-2
Wave soldering	Solder bath temperature: 260°C max., Time: 10 seconds max., Count: Once, Preheating temperature: 120°C max. (package surface temperature), Exposure limit: 3 days ^{Note} (after that, prebake at 125°C for 10 hours)	WS60-103-1
Partial heating	Pin temperature: 350°C max. Time: 3 seconds max. (per pin row)	–

Note After opening the dry pack, store it at 25°C or less and 65% RH or less for the allowable storage period.

Caution Do not use different soldering method together (except for partial heating).

★ μPD789052MC-xxx-5A4-A: 20-pin plastic SSOP (7.62 mm (300))

μPD789062MC-xxx-5A4-A: 20-pin plastic SSOP (7.62 mm (300))

μPD78E9860AMC-5A4-A: 20-pin plastic SSOP (7.62 mm (300))

μPD78E9861AMC-5A4-A: 20-pin plastic SSOP (7.62 mm (300))

Soldering Method	Soldering Conditions	Recommended Condition Symbol
Infrared reflow	Package peak temperature: 260°C, Time: 60 seconds max. (at 220°C or higher), Count: Three times or less, Exposure limit: 7 days ^{Note} (after that, prebake at 125°C for 20 to 72 hours)	IR60-207-3
Wave soldering	When the pin pitch of the package is 0.65 mm or more, wave soldering can also be performed. For details, contact an NEC Electronics sales representative.	–
Partial heating	Pin temperature: 350°C max., Time: 3 seconds max. (per pin row)	–

Note After opening the dry pack, store it at 25°C or less and 65% RH or less for the allowable storage period.

Caution Do not use different soldering methods together (except for partial heating).

Remark Products that have the part numbers suffixed by "-A" are lead-free products.

APPENDIX A DEVELOPMENT TOOLS

The following development tools are available for development of systems using the μ PD789052, 789062 Subseries. Figure A-1 shows development tools.

- Compatibility with PC98-NX Series

Unless stated otherwise, products which are supported for IBM PC/AT™ and compatibles can also be used with the PC98-NX Series. When using the PC98-NX Series, therefore, refer to the explanations for IBM PC/AT and compatibles.

- Windows™

Unless stated otherwise, "Windows" refers to the following operating systems.

- Windows 3.1
- Windows 95
- Windows 98
- Windows 2000
- Windows NT™ Ver. 4.0
- Windows XP

Figure A-1. Development Tools

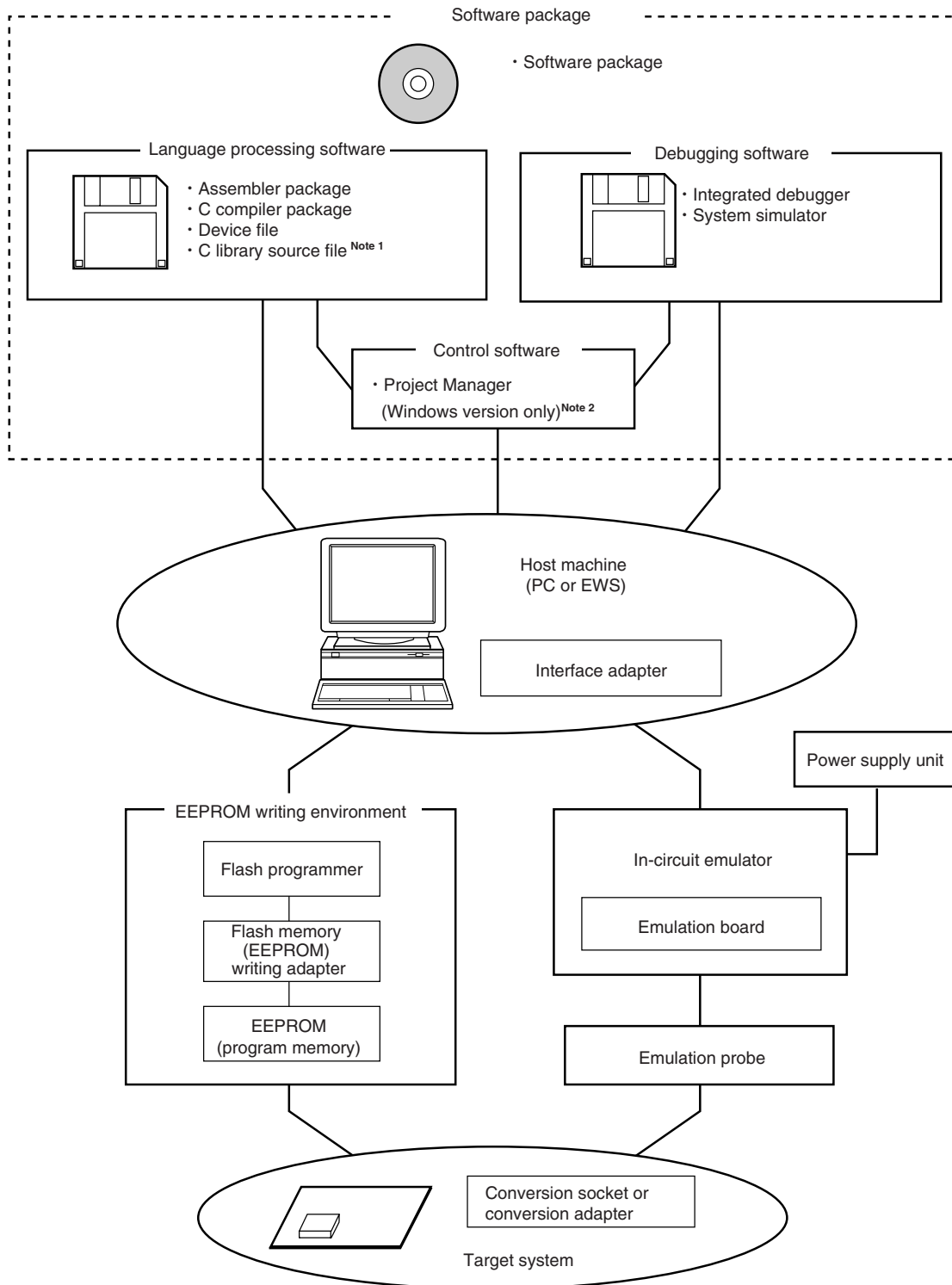

Notes 1. C library source file is not included in the software package.

2. Project Manager is included in the assembler package.

Project Manager is used only in the Windows environment.

A.1 Software Package

SP78K0S Software package	Software tools for development of the 78K/0S Series are combined in this package. The following tools are included. RA78K0S, CC78K0S, ID78K0S-NS, SM78K0S, and device files
	Part number: μ SxxxxSP78K0S

Remark xxxx in the part number differs depending on the OS used

μ SxxxxSP78K0S

xxxx	Host Machine	OS	Supply Media
AB17	PC-9800 series, IBM PC/AT	Japanese Windows	CD-ROM
BB17	compatible	English Windows	

A.2 Language Processing Software

RA78K0S Assembler package	Program that converts program written in mnemonic into object codes that can be executed by microcontroller. In addition, automatic functions to generate symbol table and optimize branch instructions are also provided. Used in combination with optional device file (DF789062 or DF789861). <Caution when used under PC environment> The assembler package is a DOS-based application but may be used under the Windows environment by using Project Manager of Windows (included in the assembler package).
	Part number: μ SxxxxRA78K0S
CC78K0S C compiler package	Program that converts program written in C language into object codes that can be executed by microcontroller. Used in combination with optional assembler package (RA78K0S) and device file (DF789062 or DF789861). <Caution when used under PC environment> The C compiler package is a DOS-based application but may be used under the Windows environment by using Project Manager of Windows (included in the assembler package).
	Part number: μ SxxxxCC78K0S
DF789062 ^{Note 1} DF789861 ^{Note 1} Device file	File containing the information inherent to the device. <ul style="list-style-type: none"> DF789062: For μPD789052, 789062 DF789861: For μPD78E9860A, 78E9861A Used in combination with optional RA78K0S, CC78K0S, ID78K0S-NS, and SM78K0S.
	Part number: μ SxxxxDF789062, μ SxxxxDF789861
CC78K0S-L ^{Note 2} C library source file	Source file of functions for generating object library included in C compiler package. Necessary for changing object library included in C compiler package according to customer's specifications. Since this is a source file, its working environment does not depend on any particular operating system.
	Part number: μ SxxxxCC78K0S-L

- Notes**
- DF789062, 789861 are common files that can be used with RA78K0S, CC78K0S, ID78K0S-NS, and SM78K0S.
 - CC78K0S-L is not included in the software package (SP78K0S).

Remark xxxx in the part number differs depending on the host machines and operating systems to be used.

μSxxxxRA78K0S

μSxxxxCC78K0S

xxxx	Host Machine	OS	Supply Media
AB13	PC-9800 series, IBM PC/AT compatible	Japanese Windows	3.5" 2HD FD
BB13		English Windows	
AB17		Japanese Windows	CD-ROM
BB17		English Windows	
3P17	HP9000 series 700™	HP-UX™ (Rel. 10.10)	
3K17	SPARCstation™	SunOS™ (Rel. 4.1.4), Solaris™ (Rel. 2.5.1)	

μSxxxxDF789062

μSxxxxDF789861

μSxxxxCC78K0S-L

xxxx	Host Machine	OS	Supply Media
AB13	PC-9800 series, IBM PC/AT compatible	Japanese Windows	3.5" 2HD FD
BB13		Japanese Windows	
3P16	HP9000 series 700	HP-UX™ (Rel. 10.10)	DAT
3K13	SPARCstation	SunOS™ (Rel. 4.1.4),	3.5" 2HD FD
3K15		Solaris™ (Rel. 2.5.1)	1/4-inch CGMT

A.3 Control Software

PM plus Project Manager	Control software created for efficient development of the user program in the Windows environment. User program development operations such as editor startup, build, and debugger startup can be performed from the Project Manager. <Caution> The Project Manager is included in the assembler package (RA78K0S). The Project Manager is used only in the Windows environment.
----------------------------	---

A.4 EEPROM (Program Memory) Writing Tools

Flashpro III (FL-PR3, PG-FP3) Flashpro IV (FL-PR4, PG-FP4) Flash programmer	Dedicated flash programmer for microcomputers incorporating flash memory (EEPROM)
FA-20MC Flash memory (EEPROM) writing adapter	Adapter for writing to flash memory (EEPROM) and connected to Flashpro III or Flashpro IV. • FA-20MC: For 20-pin plastic shrink SOP (MC-5A4 type)

Remark The FL-PR3, FL-PR4, and FA-20MC are products made by Naito Densai Machida Mfg. Co., Ltd. (TEL +81-45-475-4191).

A.5 Debugging Tools (Hardware)

IE-78K0S-NS In-circuit emulator	In-circuit emulator for debugging hardware and software of application system using the 78K0S Series. Supports an integrated debugger (ID78K0S-NS). Used in combination with an AC adapter, emulation probe, and interface adapter for connecting the host machine.
IE-78K0S-NS-A In-circuit emulator	In-circuit emulator with enhanced functions of the IE-78K0S-NS. The debug function is further enhanced by adding a coverage function and enhancing the tracer and timer functions.
IE-70000-MC-PS-B AC adapter	Adapter for supplying power from AC 100 to 240 V outlet.
IE-70000-98-IF-C Interface adapter	Adapter necessary when using PC-9800 series PC (except notebook type) as host machine (C bus supported)
IE-70000-CD-IF-A PC card interface	PC card and interface cable necessary when using notebook PC as host machine (PCMCIA socket supported)
IE-70000-PC-IF-C Interface adapter	Interface adapter necessary when using IBM PC/AT compatible as host machine (ISA bus supported)
IE-70000-PCI-IF-A Interface adapter	Adapter necessary when using personal computer incorporating PCI bus as host machine
IE-789860-NS-EM1 Emulation board	Board for emulating the peripheral hardware inherent to the device. Used in combination with in-circuit emulator.
NP-20GS Emulation probe	Cable to connect the in-circuit emulator and target system. Used in combination with the EV-9500GS-20.
EV-9500GS-20 Conversion adapter	Conversion adapter to connect the NP-20GS and a target system board on which a 20-pin plastic SSOP can be mounted.

Remark The NP-20GS is a product made by Naito Densai Machida Mfg. Co., Ltd. (TEL +81-45-475-4191).

A.6 Debugging Tools (Software)

ID78K0S-NS Integrated debugger	This debugger supports the in-circuit emulators IE-78K0S-NS and IE-78K0S-NS-A for the 78K/0S Series. The ID78K0S-NS is Windows-based software. It has improved C-compatible debugging functions and can display the results of tracing with the source program using an integrating window function that associates the source program, disassemble display, and memory display with the trace result. Used in combination with optional device file (DF789062 or DF789861). Part number: $\mu S_{xxxx}ID78K0S-NS$
SM78K0S System simulator	This is a system simulator for the 78K/0S Series. The SM78K0S is Windows-based software. It can be used to debug the target system at C source level or assembler level while simulating the operation of the target system on the host machine. Using SM78K0S, the logic and performance of the application can be verified independently of hardware development. Therefore, the development efficiency can be enhanced and the software quality can be improved. Used in combination with optional device file (DF789062 or DF789861). Part number: $\mu S_{xxxx}SM78K0S$
DF789062 ^{Note} DF789861 ^{Note} Device file	File containing the information inherent to the device. <ul style="list-style-type: none"> DF789062: For $\mu PD789052$, 789062 DF789861: For $\mu PD78E9860A$, 78E9861A Used in combination with the optional RA78K0S, CC78K0S, ID78K0S-NS, and SM78K0S. Part number: $\mu S_{xxxx}DF789062$, $\mu S_{xxxx}DF789861$

Note DF789062, 789861 are common files that can be used with RA78K0S, CC78K0S, ID78K0S-NS, and SM78K0S.

Remark xxxx in the part number differs depending on the operating systems and supply medium to be used.

$\mu S_{xxxx}ID78K0S-NS$

$\mu S_{xxxx}SM78K0S$

xxxx	Host Machine	OS	Supply Media
AB13	PC-9800 series IBM PC/AT compatibles	Japanese Windows	3.5" 2HD FD
BB13		English Windows	
AB17		Japanese Windows	CD-ROM
BB17		English Windows	

APPENDIX B NOTES ON TARGET SYSTEM DESIGN

The following shows the conditions when connecting the emulation probe to the conversion socket. Follow the configuration below and consider the shape of parts to be mounted on the target system when designing a system. Among the products described in this appendix, NP-20GS is a product of Naito Densai Machida Mfg. Co., Ltd.

Table B-1. Distance Between IE System and Conversion Socket

Emulation Probe	Conversion Socket	Distance Between IE System and Conversion Socket
NP-20GS	EV-9500GS-20	185 mm

Figure B-1. Distance Between In-Circuit Emulator and Conversion Socket

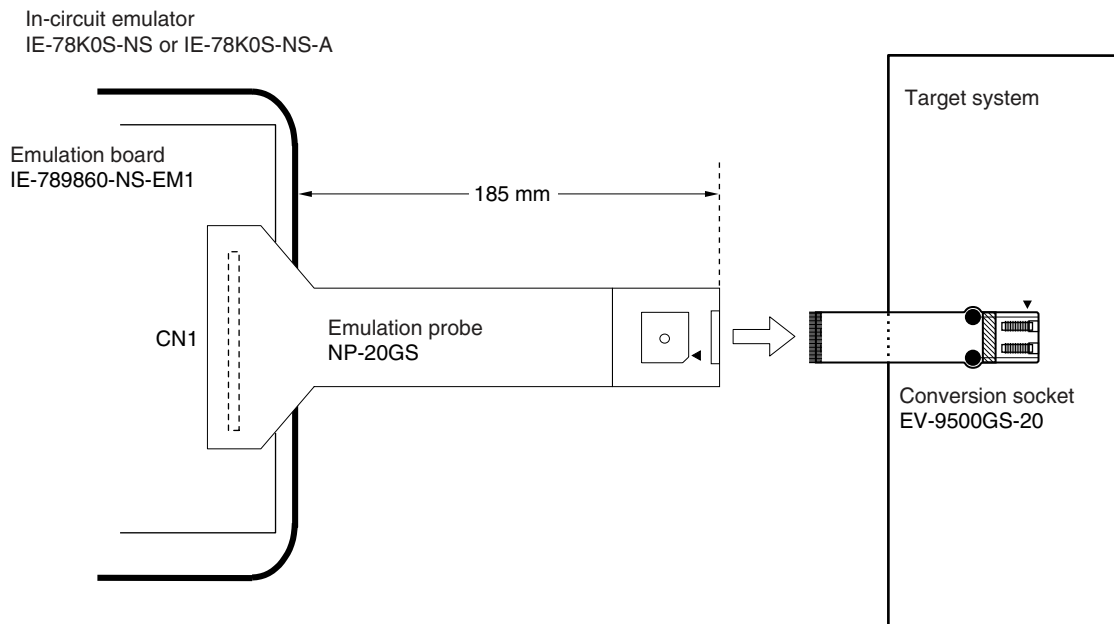
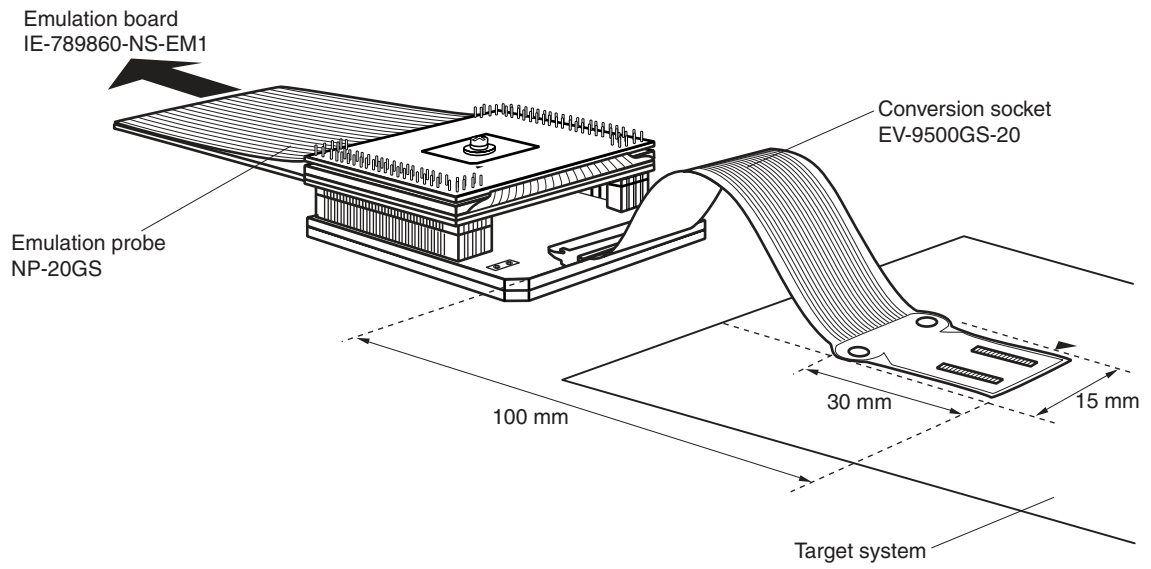

Figure B-2. Connection Conditions of Target System



APPENDIX C REGISTER INDEX

C.1 Register Name Index (in Alphabetical Order)

[B]

Bit sequential buffer 10 data registers L, H (BSFRL10, BSFRH10).....	133
Bit sequential buffer output control register 10 (BSFC10)	134

[C]

Carrier generator output control register 40 (TCA40)	93
--	----

[E]

EEPROM write control register 10 (EEWC10).....	60
8-bit compare register 30 (CR30)	89
8-bit compare register 40 (CR40)	89
8-bit compare register H40 (CRH40)	89
8-bit timer counter 30 (TM30)	89
8-bit timer counter 40 (TM40)	89
8-bit timer mode control register 30 (TMC30).....	91
8-bit timer mode control register 40 (TMC40).....	92

[I]

Interrupt mask flag register 0 (MK0)	141
Interrupt request flag register 0 (IF0)	141

[L]

Low-voltage detection level selection register 1 (LVIS1)	129
Low-voltage detection register 1 (LVIF1).....	129

[O]

Oscillation stabilization time selection register (OSTS)	151
--	-----

[P]

Port 0 (P0).....	66
Port 2 (P2).....	67
Port 4 (P4).....	68
Port mode register 0 (PM0)	69
Port mode register 2 (PM2)	69, 94
Power-on-clear register 1 (POCF1)	128
Processor clock control register (PCC).....	72, 79

[T]

Timer clock selection register 2 (TCL2)	122
---	-----

[W]

Watchdog timer mode register (WDTM)	123
---	-----

C.2 Register Symbol Index (in Alphabetical Order)

[B]

BSFC10: Bit sequential buffer output control register 10 134
 BSFRH10: Bit sequential buffer 10 data register H 133
 BSFRL10: Bit sequential buffer 10 data register L 133

[C]

CR30: 8-bit compare register 30 89
 CR40: 8-bit compare register 40 89
 CRH40: 8-bit compare register H40 89

[E]

EEWC10: EEPROM write control register 10 60

[I]

IF0: Interrupt request flag register 0 141

[L]

LVIF1: Low-voltage detection register 1 129
 LVIS1: Low-voltage detection level selection register 1 129

[M]

MK0: Interrupt mask flag register 0 141

[O]

OSTS: Oscillation stabilization time selection register 151

[P]

P0: Port 0 66
 P2: Port 2 67
 P4: Port 4 68
 PCC: Processor clock control register 72, 79
 PM0: Port mode register 0 69
 PM2: Port mode register 2 69, 94
 POCF1: Power-on-clear register 1 128

[T]

TCA40: Carrier generator output control register 40 93
 TCL2: Timer clock selection register 2 122
 TM30: 8-bit timer counter 30 89
 TM40: 8-bit timer counter 40 89
 TMC30: 8-bit timer mode control register 30 91
 TMC40: 8-bit timer mode control register 40 92

[W]

WDTM: Watchdog timer mode register 123

APPENDIX D REVISION HISTORY

Revisions up to this edition are shown below. The “Applied to” column indicates the chapter in each edition to which the revision was applied.

(1/2)

Edition	Description	Applied to	
2nd	Deletion of μ PD78E9860 and 78E9861	Throughout	
	Addition of μ PD78E9860A and 78E9861A		
	Addition of description of pin handling to 3.2.9 V_{PP} (μPD78E9860A, 78E9861A only)	CHAPTER 3 PIN FUNCTIONS	
	9.2 8-Bit Timers 30 and 40 Configuration <ul style="list-style-type: none"> • Modification of Figure 9-3 Block Diagram of Output Controller (Timer 40) • Addition of description to (2) 8-bit compare register 40 (CR40) • Addition of description to (3) 8-bit compare register H40 (CRH40) 	CHAPTER 9 8-BIT TIMERS 30 AND 40	
	Addition of Cautions to Figure 9-6 Format of Carrier Generator Output Control Register 40		
	Addition of Cautions and description to 9.4.3 Operation as carrier generator		
	9.5 Notes on Using 8-Bit Timers 30 and 40 <ul style="list-style-type: none"> • Modification of description of (1) Error on starting timer • Addition of (2) Count value if external clock input from TMI pin is selected 		
	Modification of Figure 11-1 Block Diagram of Power-on-Clear Circuit	CHAPTER 11 POWER-ON-CLEAR CIRCUITS (μ PD78E9860A, 78E9861A ONLY)	
	Modification of Figure 11-2 Block Diagram of Low-Voltage Detection Circuit		
	Addition of Note to 11.4.1 Power-on-clear (POC) circuit operation		
	Addition of Caution to 11.4.2 Operation of low-voltage detection (LVI) circuit		
	Addition of Caution to Figure 14-2 Format of Interrupt Request Flag Register 0	CHAPTER 14 INTERRUPT FUNCTIONS	
	Total revision of 17.1 EEPROM Features (Program Memory)	CHAPTER 17 μPD78E9860A, 78E9861A	
	Addition of chapter		CHAPTER 20 ELECTRICAL SPECIFICATIONS
			CHAPTER 21 EXAMPLE OF RC OSCILLATION FREQUENCY CHARACTERISTICS (REFERENCE VALUES)
			CHAPTER 22 PACKAGE DRAWING
CHAPTER 23 RECOMMENDED SOLDERING CONDITIONS			
Addition of Flashpro IV to A.4 EEPROM (Program Memory) Writing Tools	APPENDIX A DEVELOPMENT TOOLS		
Addition of notes on target system design	APPENDIX B NOTES ON TARGET SYSTEM DESIGN		
Addition of revision history	APPENDIX D REVISION HISTORY		

Edition	Description	Applied to
3 rd	<ul style="list-style-type: none"> Update of 1.5 78K/0S Series Lineup and 2.5 78K/0S Series Lineup to latest version 	CHAPTER 1 GENERAL (μPD789052 SUBSERIES)
		CHAPTER 2 GENERAL (μPD789062 SUBSERIES)
	<ul style="list-style-type: none"> Deletion of non-selectable clock settings Addition of Notes to Figure 5-2 Format of EEPROM Write Control Register 10 Modification of description of (8) in 5.4 Notes for EEPROM Writing 	CHAPTER 5 EEPROM (DATA MEMORY) (μPD78E9860A, 78E9861A ONLY)
	<ul style="list-style-type: none"> Addition of description "output to EEPROM" to Figure 9-2 Block Diagram of Timer 40 	CHAPTER 9 8-BIT TIMERS 30 AND 40
	<ul style="list-style-type: none"> Modification of a caution in Figure 14-3 Format of Interrupt Mask Flag Register 0 Modification of a signal name in Figure 14-6 Timing of Non-Maskable Interrupt Request Acknowledgment 	CHAPTER 14 INTERRUPT FUNCTIONS
	<ul style="list-style-type: none"> Specification of non-maskable interruption for HALT release in 15.2.1 HALT Mode Addition of non-maskable interruption for STOP release to 15.2.2 STOP Mode 	CHAPTER 15 STANDBY FUNCTIONS
	<ul style="list-style-type: none"> Addition of descriptions of oscillation stabilization time in Table 17-1 Differences Between μPD78E9860A, 78E9861A and Mask ROM Versions Modification of description of CLK connection in Table 17-3 Pin Connection List 	CHAPTER 17 μPD78E9860A, 78E9861A
	<ul style="list-style-type: none"> Modification of condition of supply currents of μPD78E9860A in DC Characteristics 	CHAPTER 20 ELECTRICAL SPECIFICATIONS
<ul style="list-style-type: none"> Modification of soldering conditions of μPD789052 and 789062 in Table 23-1 Surface Mounting Type Soldering Conditions 	CHAPTER 23 RECOMMENDED SOLDERING CONDITIONS	
3 rd (modification version)	<ul style="list-style-type: none"> Addition of lead-free products 	CHAPTER 1 GENERAL (μPD789052 SUBSERIES)
		CHAPTER 2 GENERAL (μPD789062 SUBSERIES)
	<ul style="list-style-type: none"> Addition of soldering conditions of lead-free products in Table 23-1 Surface Mounting Type Soldering Conditions 	CHAPTER 23 RECOMMENDED SOLDERING CONDITIONS