



# STEVAL-CBL011V1

DiSEqC 1.X-compliant dual LNB supply and control IC based on the LNBH26

Data brief

## Features

- Complete interface between LNB and I<sup>2</sup>C bus
- Built-in DC-DC converter for single 12 V supply operation and high efficiency (typ. 93% @ 0.5 A)
- Selectable output current limit by external resistor
- Compliant with main satellite receiver output voltage specification (15 programmable levels)
- Accurate built-in 22 kHz tone generator compliant with widely accepted standards
- 22 kHz tone waveform integrity guaranteed also in no load condition
- Low drop post regulator and high efficiency step-up PWM with integrated power N-MOS for low power loss
- LPM (low power mode) function to reduce dissipation
- Overload and overtemperature internal protection with I<sup>2</sup>C diagnostic bits
- LNB short-circuit dynamic protection
- RoHS compliant

## Description

The STEVAL-CBL011V1 demonstration board implements a DC-DC converter based on ST's LNBH26 device. It is used to power LNBs in dish antennas to receive satellite TV signals.

The LNBH26 is an integrated solution for supplying/interfacing satellite LNB modules in accordance with international standards.

This single device offers a complete solution for dual-tuner satellite receivers and provides good performance at low cost using a low external component count.



The LNBH26 demonstration board includes an I<sup>2</sup>C bus interface and a factory-trimmed internal 22 kHz tone generator which can be controlled through the DSQIN pin (TTL compatible). This allows immediate DiSEqC™ data encoding.

Thanks to a fully integrated step-up DC-DC converter, the STEVAL-CBL011V1 demonstration board can operate with a single input voltage supply source, ranging from 8 to 15 V.

# 1 Schematic diagram

Figure 1. STEVAL-CBL011V1 circuit schematic

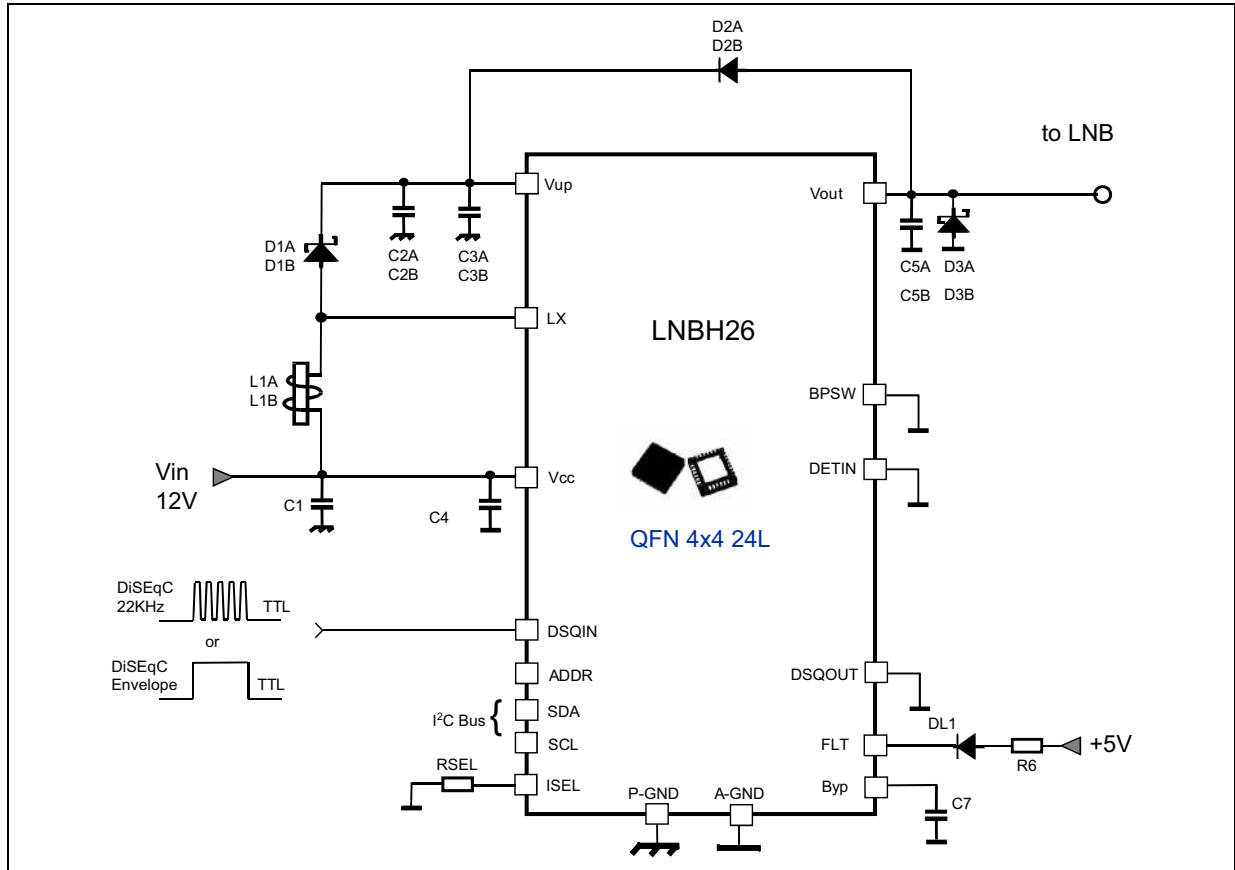

## 2 Revision history

Table 1. Document revision history

Date	Revision	Changes
11-Feb-2013	1	Initial release.

**Please Read Carefully:**

Information in this document is provided solely in connection with ST products. STMicroelectronics NV and its subsidiaries ("ST") reserve the right to make changes, corrections, modifications or improvements, to this document, and the products and services described herein at any time, without notice.

All ST products are sold pursuant to ST's terms and conditions of sale.

Purchasers are solely responsible for the choice, selection and use of the ST products and services described herein, and ST assumes no liability whatsoever relating to the choice, selection or use of the ST products and services described herein.

No license, express or implied, by estoppel or otherwise, to any intellectual property rights is granted under this document. If any part of this document refers to any third party products or services it shall not be deemed a license grant by ST for the use of such third party products or services, or any intellectual property contained therein or considered as a warranty covering the use in any manner whatsoever of such third party products or services or any intellectual property contained therein.

**UNLESS OTHERWISE SET FORTH IN ST'S TERMS AND CONDITIONS OF SALE ST DISCLAIMS ANY EXPRESS OR IMPLIED WARRANTY WITH RESPECT TO THE USE AND/OR SALE OF ST PRODUCTS INCLUDING WITHOUT LIMITATION IMPLIED WARRANTIES OF MERCHANTABILITY, FITNESS FOR A PARTICULAR PURPOSE (AND THEIR EQUIVALENTS UNDER THE LAWS OF ANY JURISDICTION), OR INFRINGEMENT OF ANY PATENT, COPYRIGHT OR OTHER INTELLECTUAL PROPERTY RIGHT.**

**UNLESS EXPRESSLY APPROVED IN WRITING BY TWO AUTHORIZED ST REPRESENTATIVES, ST PRODUCTS ARE NOT RECOMMENDED, AUTHORIZED OR WARRANTED FOR USE IN MILITARY, AIR CRAFT, SPACE, LIFE SAVING, OR LIFE SUSTAINING APPLICATIONS, NOR IN PRODUCTS OR SYSTEMS WHERE FAILURE OR MALFUNCTION MAY RESULT IN PERSONAL INJURY, DEATH, OR SEVERE PROPERTY OR ENVIRONMENTAL DAMAGE. ST PRODUCTS WHICH ARE NOT SPECIFIED AS "AUTOMOTIVE GRADE" MAY ONLY BE USED IN AUTOMOTIVE APPLICATIONS AT USER'S OWN RISK.**

Resale of ST products with provisions different from the statements and/or technical features set forth in this document shall immediately void any warranty granted by ST for the ST product or service described herein and shall not create or extend in any manner whatsoever, any liability of ST.

ST and the ST logo are trademarks or registered trademarks of ST in various countries.

Information in this document supersedes and replaces all information previously supplied.

The ST logo is a registered trademark of STMicroelectronics. All other names are the property of their respective owners.

© 2013 STMicroelectronics - All rights reserved

STMicroelectronics group of companies

Australia - Belgium - Brazil - Canada - China - Czech Republic - Finland - France - Germany - Hong Kong - India - Israel - Italy - Japan - Malaysia - Malta - Morocco - Philippines - Singapore - Spain - Sweden - Switzerland - United Kingdom - United States of America

[www.st.com](http://www.st.com)