



Z86E61/Z86E63

**CMOS Z8 16K/32K EPROM
Microcontroller**

Product Specification

PS014401-1001

 **Warning:** DO NOT USE IN LIFE SUPPORT

LIFE SUPPORT POLICY

ZILOG'S PRODUCTS ARE NOT AUTHORIZED FOR USE AS CRITICAL COMPONENTS IN LIFE SUPPORT DEVICES OR SYSTEMS WITHOUT THE EXPRESS PRIOR WRITTEN APPROVAL OF THE PRESIDENT AND GENERAL COUNSEL OF ZILOG CORPORATION.

As used herein

Life support devices or systems are devices which (a) are intended for surgical implant into the body, or (b) support or sustain life and whose failure to perform when properly used in accordance with instructions for use provided in the labeling can be reasonably expected to result in a significant injury to the user. A critical component is any component in a life support device or system whose failure to perform can be reasonably expected to cause the failure of the life support device or system or to affect its safety or effectiveness.

Document Disclaimer

©2008 by Zilog, Inc. All rights reserved. Information in this publication concerning the devices, applications, or technology described is intended to suggest possible uses and may be superseded. ZILOG, INC. DOES NOT ASSUME LIABILITY FOR OR PROVIDE A REPRESENTATION OF ACCURACY OF THE INFORMATION, DEVICES, OR TECHNOLOGY DESCRIBED IN THIS DOCUMENT. ZILOG ALSO DOES NOT ASSUME LIABILITY FOR INTELLECTUAL PROPERTY INFRINGEMENT RELATED IN ANY MANNER TO USE OF INFORMATION, DEVICES, OR TECHNOLOGY DESCRIBED HEREIN OR OTHERWISE. The information contained within this document has been verified according to the general principles of electrical and mechanical engineering.

Z8, Z8 Encore!, Z8 Encore! XP, Z8 Encore! MC, Crimzon, eZ80, and ZNEO are trademarks or registered trademarks of Zilog, Inc. All other product or service names are the property of their respective owners.



**ISO 9001:2000
FS 507510**

Zilog products are designed and manufactured under an ISO registered 9001:2000 Quality Management System. For more details, please visit www.zilog.com/quality.



Table of Contents

FEATURES	1
GENERAL DESCRIPTION	2
PIN FUNCTIONS	11
ROMless (Input, Active Low)	11
DS (Output, Active Low)	11
AS (Output, Active Low)	11
XTAL2, XTAL1	11
R/W (Output, Write Low)	11
RESET (Input, Active Low)	11
Port 0 (P07-P00)	12
Port 1 (P17-P10)	12
UART OPERATION	17
ADDRESS SPACE	18
FUNCTIONAL DESCRIPTION	22
Counter/Timers	22
Interrupts	23
PROGRAMMING	26
Z86E61/E63 User Modes	26
Z86E63 Signal Description for EPROM Program/Read	27
ABSOLUTE MAXIMUM RATINGS	34
STANDARD TEST CONDITIONS	34
DC CHARACTERISTICS	35
AC CHARACTERISTICS	36
AC CHARACTERISTICS	39
Z8 CONTROL REGISTER DIAGRAMS	41
DC CHARACTERISTICS	49
Supply Current	49
DC CHARACTERISTICS	50
Standby Current	50
INSTRUCTION SET NOTATION	50
INSTRUCTION FORMATS	53
INSTRUCTION SUMMARY	53
OPCODE MAP	60
PACKAGE INFORMATION	61
ORDERING INFORMATION	62
CODES	63

Z86E61/E63
CMOS Z8 16K/32K EPROM Microcontroller



iv



List of Figures

Figure 1.	Z86E61/E63 Functional Block Diagram	3
Figure 2.	40-Pin DIP Pin Configuration	4
Figure 3.	44-Pin PLCC Pin Configuration	6
Figure 4.	40-Pin DIP Pin Configuration	8
Figure 5.	44-Pin PLCC Pin Configuration	9
Figure 6.	Port 0 Configuration	13
Figure 7.	Port 1 Configuration	14
Figure 8.	Port 2 Configuration	15
Figure 9.	Port 3 Configuration	16
Figure 10.	Serial Data Formats	17
Figure 11.	Program Memory Configuration	18
Figure 12.	Data Memory Configuration	20
Figure 13.	Register File	21
Figure 14.	Register Pointer	22
Figure 15.	Counter/Timers Block Diagram	23
Figure 16.	Interrupt Block Diagram	24
Figure 17.	Oscillator Configuration	25
Figure 18.	EPROM Read	29
Figure 19.	EPROM Program and Verity	30
Figure 20.	Programming EPROM, RAM Protect, and 4K Size Selection	31
Figure 21.	Programming EPROM, RAM Protect, and 16K Size Selection	32
Figure 22.	Intelligent Programming Flowchart	33
Figure 23.	Test Load Diagram	34
Figure 24.	External I/O or Memory Read/Write Timing	36
Figure 25.	Additional Timing	38
Figure 26.	Input Handshake Timing	39
Figure 27.	Output Handshake Timing	40
Figure 28.	Serial I/O Register (F0H: Read/Write)	41
Figure 29.	Timer Mode Register (F1H: Read/Write)	41
Figure 30.	Counter/Timer 1 Register (F2H: Read/Write)	42
Figure 31.	Prescaler 1 Register (F3H: Write Only)	42
Figure 32.	Counter/Timer 0 Register (F4H: Read/Write)	42
Figure 33.	Prescaler 0 Register (F5H: Write Only)	43
Figure 34.	Port 2 Mode Register (F6H: Write Only)	43



Figure 35. Port 3 Mode Register (F7H: Write Only)	44
Figure 36. Port 0 and 1 Mode Register (F8H: Write Only)	45
Figure 37. Interrupt Priority Register (F9H: Write Only)	46
Figure 38. Interrupt Request Register (FAH: Read/Write)	46
Figure 39. Interrupt Mask Register (FBH: Read/Write)	47
Figure 40. Flag Register (FCH: Read/Write)	47
Figure 41. Register Pointer Register (FDH: Read/Write)	48
Figure 42. Stack Pointer Register (FEH: Read/Write)	48
Figure 43. Stack Pointer Register (FFH: Read/Write)	48
Figure 44. Typical ICC vs. Frequency	49
Figure 45. Typical ICC1 vs. Frequency	50
Figure 46. Instruction Formats	53
Figure 47. Opcode Map	60
Figure 48. 40-Pin DIP Package Diagram	61
Figure 49. 44-Pin PLCC Package Diagram	61
Figure 50. 44-Pin LQFP Package Diagram	62



List of Tables

Table 1. 40-Pin DIP Pin Identification.	4
Table 2. 44-Pin PLCC Pin Identification.	6
Table 3. 40-Pin DIP Pin Identification.	8
Table 4. 44-Pin PLCC Pin Identification.	10
Table 5. Port 3 Pin Assignments	16
Table 6. OTP Programming	27
Table 7. Timing of Programming Waveforms.	28
Table 8. Absolute Maximum Ratings	34
Table 9. DC Characteristics	35
Table 10. External I/O or Memory Read and Write Timing	36
Table 11. Clock Dependent Formulas	37
Table 12. Additional Timing	39
Table 13. Handshake Timing	40
Table 14. Instruction Set Notation	50
Table 15. Condition Codes.	52
Table 16. Instruction Summary	54

Z86E61/E63
CMOS Z8 16K/32K EPROM Microcontroller



viii



FEATURES

- 8-Bit CMOS Microcontroller
- 40-Pin DIP, 44-Pin PLCC, 44-Pin LQFP Style Packages
- 4.5V to 5.5V Operating Range
- Clock Speeds: 16 and 20 MHz
- Low Power Consumption: 275 mW (max)
- Fast Instruction Pointer: 1.0 ms @ 12 MHz
- Two Standby Modes: STOP and HALT
- 32 Input/Output Lines
- Full-Duplex UART
- All Digital Inputs are TTL Levels
- Auto Latches
- High Voltage Protection on High Voltage Inputs
- RAM and EPROM Protect
- EPROM:
 - 16 Kbytes Z86E61
 - 32 Kbytes Z86E63
- 256 Bytes Register File
 - 236 Bytes of General-Purpose RAM
 - 16 Bytes of Control and Status Registers
 - 4 Bytes for Ports
- Two Programmable 8-Bit Counter/Timers. Each with 6-Bit Programmable Prescaler
- Six Vectored, Priority Interrupts from Eight Different Sources
- On-Chip Oscillator that accepts a Crystal, Ceramic Resonator, LC, or External Clock Drive



GENERAL DESCRIPTION

The Z86E61/E63 microcontrollers are members of the Z8® single-chip microcontroller family with 16K/32 Kbytes of EPROM and 236 bytes of general-purpose RAM. Offered in 40-pin DIP, 44-pin PLCC or 44-Pin LQFP package styles, these devices are pin-compatible EPROM versions of the Z86C61/ 63. The ROMless pin option is available on the 44-pin versions only.

With 4 Kbytes of ROM and 236 bytes of general-purpose RAM, the Z86E61/E63 offers fast execution, efficient use of memory, sophisticated interrupts, input/output bit manipulation capabilities, and easy hardware/software system expansion.

For applications demanding powerful I/O capabilities, the Z86E61/E63 offers 32 pins dedicated to input and output. These lines are grouped into four ports. Each port consists of eight lines, and is configurable under software control to provide timing, status signals, serial or parallel I/O with or without handshake, and an address/data bus for interfacing external memory.

The Z86E61/E63 can address both external memory and preprogrammed ROM, making it well suited for high-volume applications or where code flexibility is required. There are three basic address spaces available to support this configuration: Program Memory, Data Memory, and 236 general-purpose registers.

To unburden the system from coping with real-time tasks such as counting/timing and serial data communication, the Z86E61/E63 offers two on-chip counter/timers with a large number of user selectable modes (Figure 1).

Power connections follow conventional descriptions below:

Connection	Circuit	Device
Power	V _{CC}	V _{DD}
Ground	GND	V _{SS}

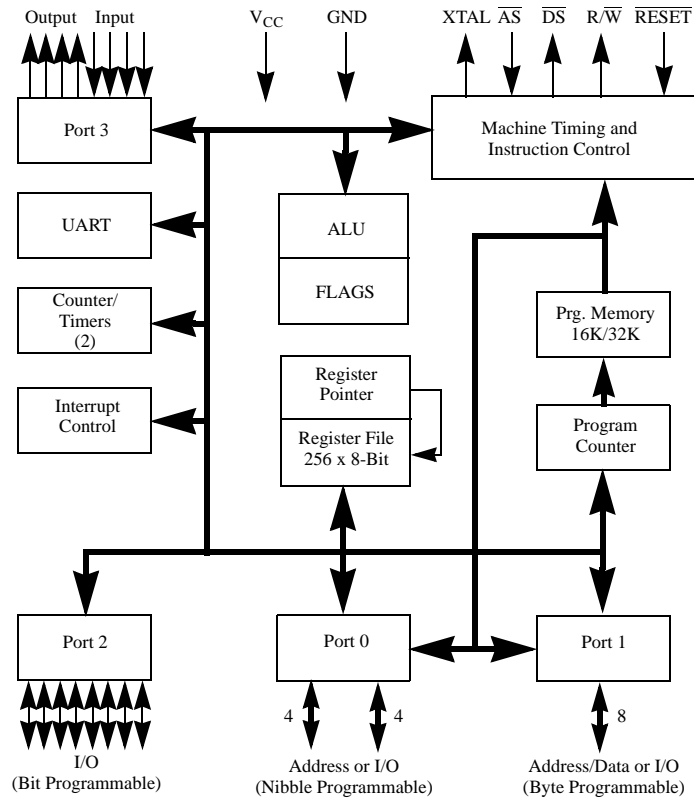
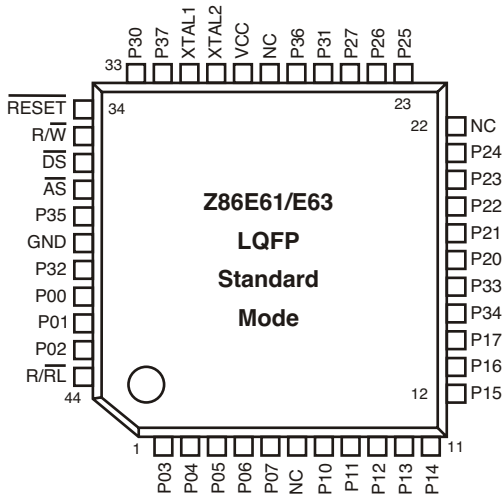
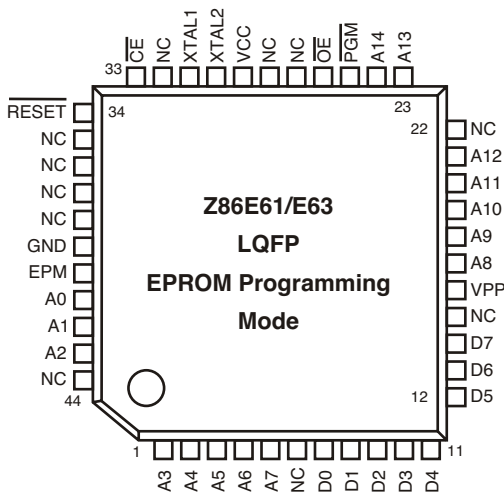

Figure 1. Z86E61/E63 Functional Block Diagram



Pin Description - Standard Mode

XTAL2	Crystal Oscillator Clock	Output
XTAL1	Crystal Oscillator Clock	Input
RESET	Reset	Input
R/W	Read/Write	Output
DS	Data Strobe	Output
AS	Address Strobe	Output
P00-P07 Port 0	8 bit General IO	Input/Output
P10-P17 Port 1	8 bit General IO	Input/Output
P20-P27 Port 2	8 bit General IO	Input/Output
P30-P33 Port 3	4 bit Input	Input
P34-P37 Port 3	4 bit Output	Output
R/RL	ROM/ROMless Ctrl	Input
GND	Ground	Input
VCC	Power Supply	Input



Pin Description - EPROM Programming Mode

XTAL2	Crystal Oscillator Clock	Output
XTAL1	Crystal Oscillator Clock	Input
CE	Chip Enable	Input
RESET	Reset	Input
EPM	EPROM Prog Mode	Input
A0-A14	15-bit Address bus	Input
D7-D0	8-bit Data bus	Input/Output
VPP	Prog Voltage	Input
PGM	Prog Mode	Input
OE	Output Enable	Input
NC	Not Connected	Input
GND	Ground	Input
VCC	Power Supply	Input

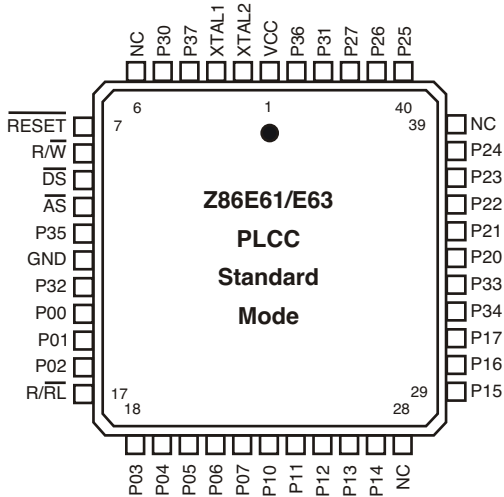

Pin Description - Standard Mode

XTAL2	Crystal Oscillator Clock	Output
XTAL1	Crystal Oscillator Clock	Input
RESET	Reset	Input
R/W	Read/Write	Output
DS	Data Strobe	Output
AS	Address Strobe	Output
P00-P07 Port 0	8 bit General IO	Input/Output
P10-P17 Port 1	8 bit General IO	Input/Output
P20-P27 Port 2	8 bit General IO	Input/Output
P30-P33 Port 3	4 bit Input	Input
P34-P37 Port 3	4 bit Output	Output
R/RL	ROM/ROMless Ctrl	Input
GND	Ground	Input
VCC	Power Supply	Input

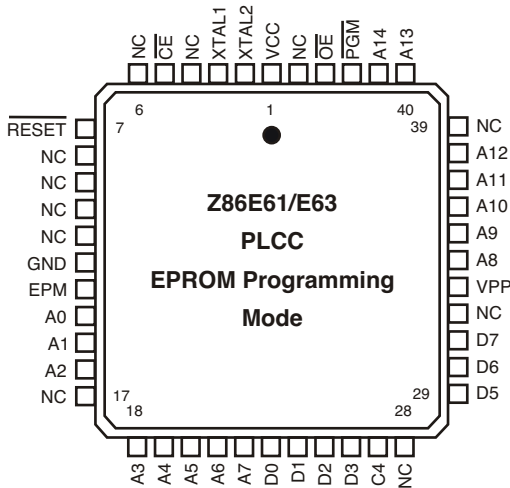

Pin Description - EPROM Programming Mode

XTAL2	Crystal Oscillator Clock	Output
XTAL1	Crystal Oscillator Clock	Input
CE	Chip Enable	Input
RESET	Reset	Input
EPM	EPROM Prog Mode	Input
A0-A14	15-bit Address bus	Input
D7-D0	8-bit Data bus	Input/Output
VPP	Prog Voltage	Input
PGM	Prog Mode	Input
OE	Output Enable	Input
NC	Not Connected	Input
GND	Ground	Input
VCC	Power Supply	Input

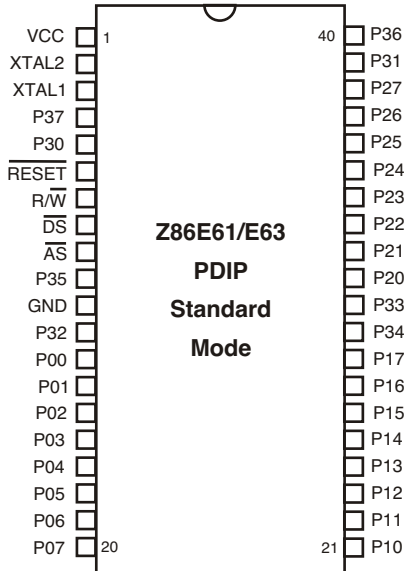

Pin Description - Standard Mode

XTAL2	Crystal Oscillator Clock	Output
XTAL1	Crystal Oscillator Clock	Input
$\overline{\text{RESET}}$	Reset	Input
$\overline{\text{R/W}}$	Read/Write	Output
$\overline{\text{DS}}$	Data Strobe	Output
$\overline{\text{AS}}$	Address Strobe	Output
P00-P07 Port 0	8 bit General IO	Input/Output
P10-P17 Port 1	8 bit General IO	Input/Output
P20-P27 Port 2	8 bit General IO	Input/Output
P30-P33 Port 3	4 bit Input	Input
P34-P37 Port 3	4 bit Output	Output
GND	Ground	Input
VCC	Power Supply	Input

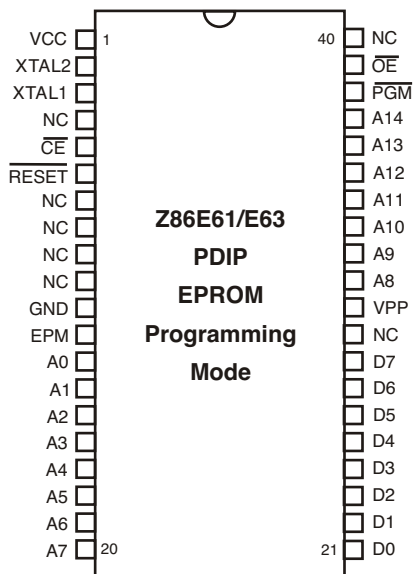

Pin Description - EPROM Programming Mode

XTAL2	Crystal Oscillator Clock	Output
XTAL1	Crystal Oscillator Clock	Input
$\overline{\text{CE}}$	Chip Enable	Input
$\overline{\text{RESET}}$	Reset	Input
$\overline{\text{EPM}}$	EPROM Prog Mode	Input
A0-A14	15-bit Address bus	Input
D7-D0	8-bit Data bus	Input/Output
VPP	Prog Voltage	Input
PGM	Prog Mode	Input
$\overline{\text{OE}}$	Output Enable	Input
$\overline{\text{NC}}$	Not Connected	Input
GND	Ground	Input
VCC	Power Supply	Input



PIN FUNCTIONS

ROMless (Input, Active Low).

Connecting this pin to GND disables the internal ROM and forces the device to function as a Z86C91 ROMless Z8 (see the Z86C91 product specification for more information). When pulled High to V_{CC} , the device functions as a normal Z86E61/E63 EPROM version.

- **Note:** This pin is only available on the 44-pin versions of the Z86E61/E63.

\overline{DS} (Output, Active Low).

Data Strobe is activated once for each external memory transfer. For a READ operation, data must be available prior to the trailing edge of \overline{DS} . For WRITE operations, the falling edge of \overline{DS} indicates that output data is valid.

\overline{AS} (Output, Active Low).

Address Strobe is pulsed once at the beginning of each machine cycle. Address output is through Port 1 for all external programs. Memory address transfers are valid at the trailing edge of \overline{AS} . Under program control, \overline{AS} can be placed in the high-impedance state along with Ports 0 and 1, Data Strobe, and Read/Write.

XTAL2, XTAL1

Crystal 2, Crystal 1 (time-based input and output, respectively). These pins connect a parallel-resonant crystal, ceramic resonator, LC, or any external single-phase clock to the on-chip oscillator and buffer.

$\overline{R/W}$ (Output, Write Low).

The Read/Write signal is Low when the MCU is writing to the external program or data memory.

\overline{RESET} (Input, Active Low).

To avoid asynchronous and noisy reset problems, the Z86E61/E63 is equipped with a reset filter of four external clocks (4TpC). If the external \overline{RESET} signal is less than 4TpC in duration, no reset occurs.



On the fifth clock after the $\overline{\text{RESET}}$ is detected, an internal RST signal is latched and held for an internal register count of 18 external clocks, or for the duration of the external $\overline{\text{RESET}}$, whichever is longer. During the reset cycle, $\overline{\text{DS}}$ is held active Low while $\overline{\text{AS}}$ cycles at a rate of $T_{\text{pC}}/2$. When $\overline{\text{RESET}}$ is deactivated, program execution begins at location 000C (HEX). Power-up reset time must be held low for 50 ms, or until V_{CC} is stable, whichever is longer.

Port 0 (P07-P00)

Port 0 is an 8-bit, nibble programmable, bidirectional, TTL compatible port. These eight I/O lines can be configured under software control as a nibble I/O port, or as an address port for interfacing external memory. When used as an I/O port, Port 0 may be placed under handshake control. In this configuration, Port 3, lines P32 and P35 are used as the handshake control $\overline{\text{DAV0}}$ and $\overline{\text{RDY0}}$ (Data Available and Ready). Handshake signal assignment is dictated by the I/O direction of the upper nibble P07-P04. The lower nibble must have the same direction as the upper nibble to be under handshake control.

For external memory references, Port 0 can provide address bits A11-A8 (lower nibble) or A15-A8 (lower and upper nibbles) depending on the required address space. If the address range requires 12 bits or less, the upper nibble of Port 0 can be programmed independently as I/O while the lower nibble is used for addressing. If one or both nibbles are needed for I/O operation, they must be configured by writing to the Port 0 Mode register.

In ROMless mode, after a hardware reset, Port 0 lines are defined as address lines A15-A8, and extended timing is set to accommodate slow memory access. The initialization routine can include reconfiguration to eliminate this extended timing mode (Figure 8).

Port 1 (P17-P10)

Port 1 is an 8-bit, byte programmable, bidirectional, TTL compatible port. It has multiplexed Address (A7-A0) and Data (D7-D0) ports. For Z86E61/E63, these eight I/O lines can be programmed as input or output lines or are configured under software control as an address/data port for interfacing external memory. When used as an I/O port, Port 1 can be placed under handshake control. In this configuration, Port 3 lines, P33 and P34, are used as the handshake controls $\overline{\text{RDY1}}$ and $\overline{\text{DAV1}}$.

Memory locations greater than 16384 (E61) or 32768 (E63) are referenced through Port 1. To interface external memory, Port 1 must be programmed for the multiplexed Address/ Data mode. If more than 256 external locations are required, Port 0 must output the additional lines.

Port 1 can be placed in high-impedance state along with Port 0, \overline{AS} , \overline{DS} , and R/\overline{W} , allowing the MCU to share common resources in multiprocessor and DMA applications. Data transfers are controlled by assigning P33 as a Bus Acknowledge input, and P34 as a Bus Request output (Figure 7).

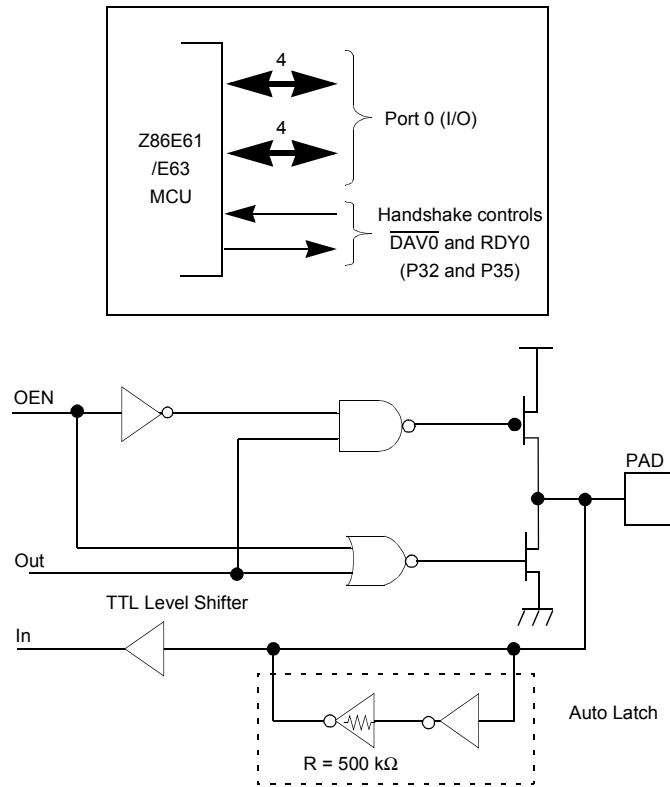

Figure 6. Port 0 Configuration

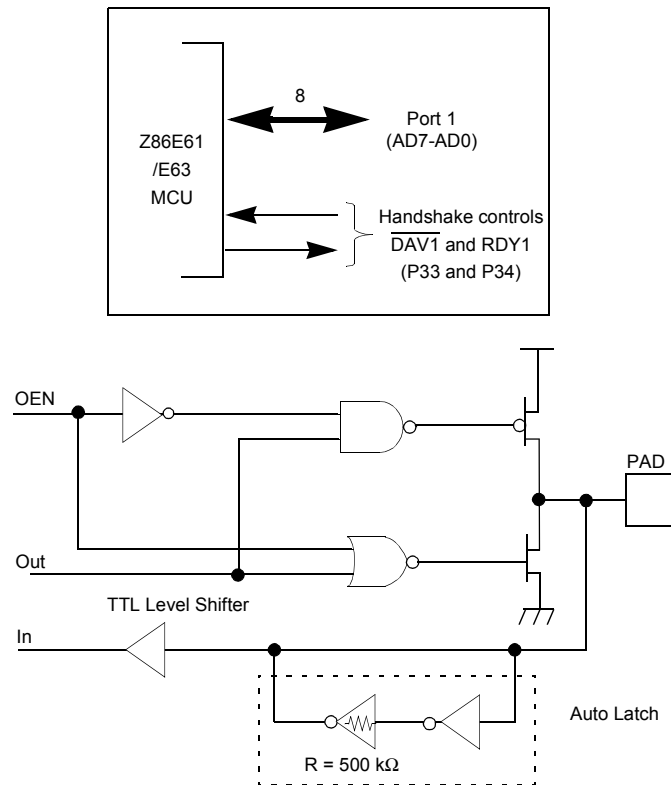

Figure 7. Port 1 Configuration

Port 2 (P27-P20). Port 2 is an 8-bit, bit programmable, bi-directional, CMOS compatible port. Each of these eight I/O lines can be independently programmed as an input or output, or globally as an open-drain output. Port 2 is always available for I/O operation. When used as an I/O port, Port 2 can be placed under handshake control. In this configuration, Port 3 lines P31 and P36 are used as the handshake control lines $\overline{DAV2}$ and RDY2. The handshake signal assignment for Port 3 lines, P31 and P36, is dictated by the direction (input or output) assigned to P27 (Figure 8 and Table 21 on page 16).

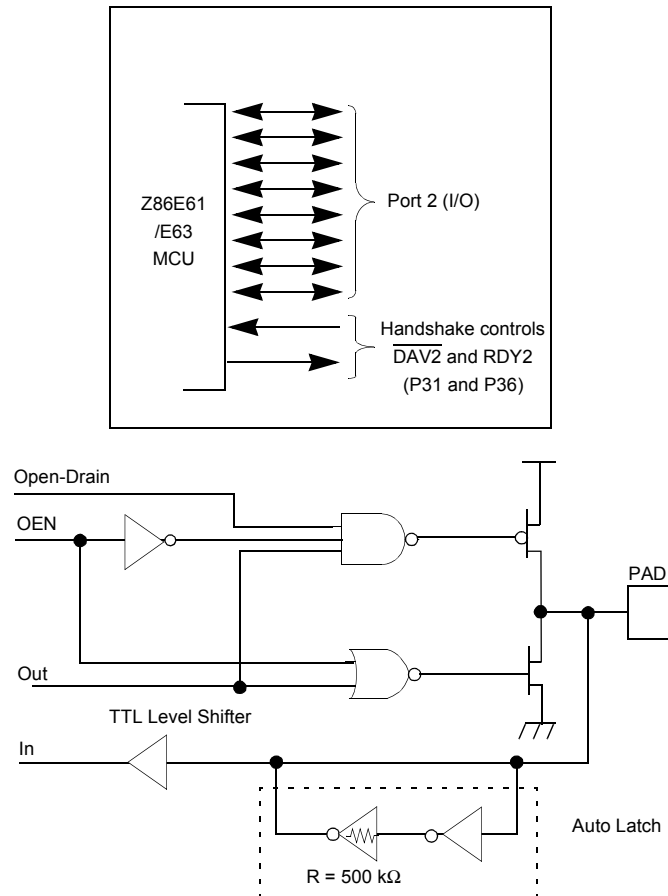

Figure 8. Port 2 Configuration

Port 3 (P37-P30). Port 3 is an 8-bit, CMOS compatible four-fixed input and four-fixed output port. These eight I/O lines have four-fixed (P33-P30) input and four-fixed (P37-P34) output ports. Port 3, when used as serial I/O, is programmed as serial in and serial out, respectively (Figure 9).

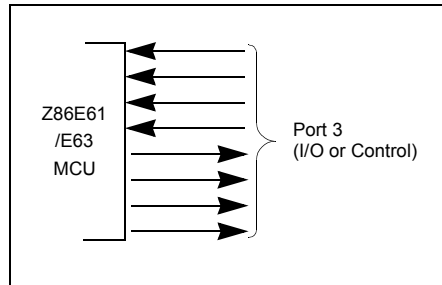

Figure 9. Port 3 Configuration

Port 3 is configured under software control to provide the following control functions: handshake for Ports 0 and 2 (\overline{DAV} and RDY); four external interrupt request signals (IRQ3-IRQ0); timer input and output signals (T_{IN} and T_{OUT}) Data Memory Select (\overline{DM}) and EPROM control signals (P30 = \overline{CE} , P31 = \overline{OE} , P32 = EPM and P33 = V_{PP}).

Table 21. Port 3 Pin Assignments

Pin	I/O	CTCI	Int.	P0 HS	P1 HS	P2 HS	UART	Ext	EPROM
P30	IN	T_{IN}	IRQ3				Serial In		\overline{CE}
P31	IN	T_{IN}	IRQ2			D/R			\overline{OE}
P32	IN	T_{IN}	IRQ0	D/R					EPM
P33	IN	T_{IN}	IRQ1		D/R				V_{PP}
P34	OUT	T_{OUT}			R/D			DM	
P35	OUT	T_{OUT}		R/D					
P36	OUT	T_{OUT}				R/D			
P37	OUT	T_{OUT}					Serial Out		
T0			IRQ4						
T1			IRQ5						

1. HS = Handshake Signals D = Data Available R = Ready

UART OPERATION

Port 3 lines, P37 and P30, are programmed as serial I/O lines for full-duplex serial asynchronous receiver/transmitter operation. The bit rate is controlled by Counter/Timer0.

The Z86E61/E63 automatically adds a start bit and two stop bits to transmitted data (Figure 10). Odd parity is also available as an option. Eight data bits are always transmitted, regardless of parity selection. If parity is enabled, the eighth bit is the odd parity bit. An interrupt request (IRQ4) is generated on all transmitted characters.

Received data must have a start bit, eight data bits, and at least one stop bit. If parity is on, bit 7 of the received data is replaced by a parity error flag. Received characters generate the IRQ3 interrupt request.

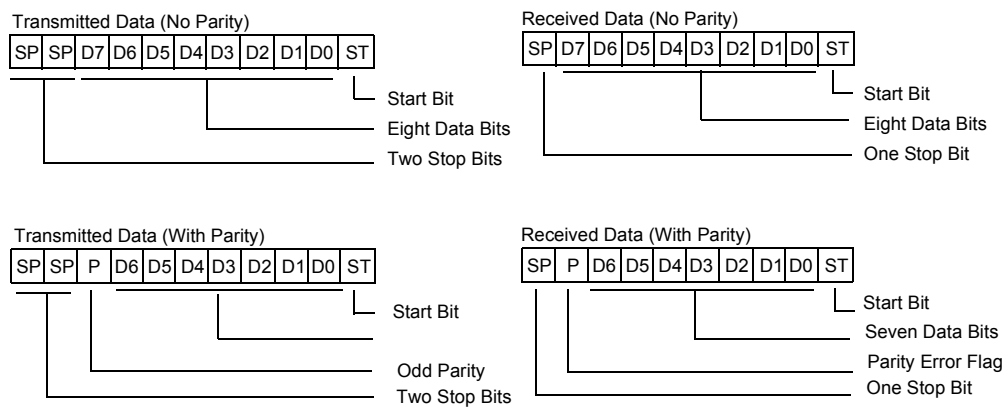

Figure 10. Serial Data Formats

Auto Latch

The Auto Latch puts valid CMOS levels on all CMOS inputs that are not externally driven. This reduces excessive supply current flow in the input buffer when it is not driven by any source.

- **Note:** P33-P30 inputs differ from the Z86C61/C63 in that there is no clamping diode to V_{CC} because of the EPROM high voltage detection circuits. Exceeding the V_{IH} maximum specification during standard operating mode may cause the device to enter EPROM mode.

ADDRESS SPACE

Program Memory. The Z86E61/E63 can address 48 Kbytes (E61) or 32 Kbytes (E63) of external program memory (Figure 11). The first 12 bytes of program memory are reserved for the interrupt vectors. These locations contain six 16-bit vectors that correspond to the six available interrupts. For EPROM mode, byte 13 to byte 16383 (E61) or 32767 (E63) consists of on-chip EPROM. At addresses 16384 (E61) or 32768 (E63) and above, the Z86E61/E63 executes external program memory fetches. In ROMless mode, the Z86E61/E63 can address up to 64 Kbytes of program memory. Program execution begins at external location 000C (HEX) after a reset.

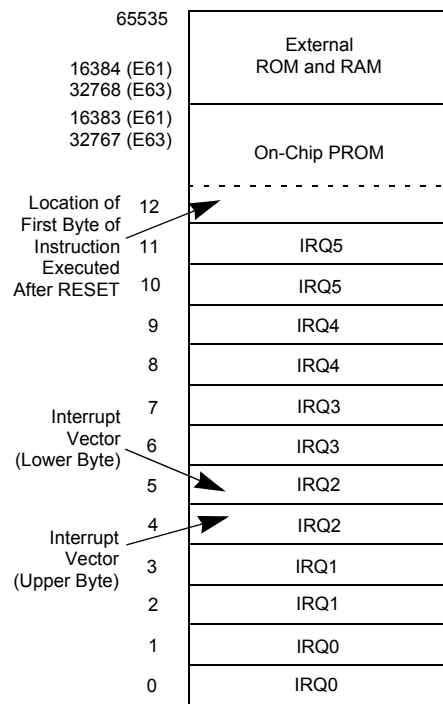

Figure 11. Program Memory Configuration

Data Memory (\overline{DM})

The EPROM version can address up to 48 Kbytes (E61) or 32 Kbytes (E63) of external data memory space beginning at location 16384 (E61) or 32768 (E63). The ROMless version can address up to 64 Kbytes of external data memory. External data memory may be included with, or separated from, the external program memory space. \overline{DM} , an optional I/O function that can be programmed to appear on pin P34, is used to distinguish between data and program memory



space (Figure 12). The state of the \overline{DM} signal is controlled by the type instruction being executed. An LDC opcode references PROGRAM (DM inactive) memory, and an LDE instruction references DATA (DM active Low) memory.

Register File

The register file consists of four I/O port registers, 236 general-purpose registers, and 16 control and status registers (Figure 13). The instructions can access registers directly or indirectly through an 8-bit address field. The Z86E61/E63 also allows short 4-bit register addressing using the Register Pointer (Figure 14). In the 4-bit mode, the Register File is divided into 16 working register groups, each occupying 16 continuous locations. The Register Pointer addresses the starting location of the active working register group.

Stack

The Z86E61/E63 has a 16-bit Stack Pointer (R255-R254) used for external stacks that reside anywhere in the data memory for the ROMless mode, but only from 16384 (E61) or 32768 (E63) to 65535 in the EPROM mode. An 8-bit Stack Pointer (R255) is used for the internal stack that resides within the 236 general-purpose registers (R239-R4). The high byte of the Stack Pointer (SPH Bits 15-8) can be used as a general purpose register when using internal stack only.

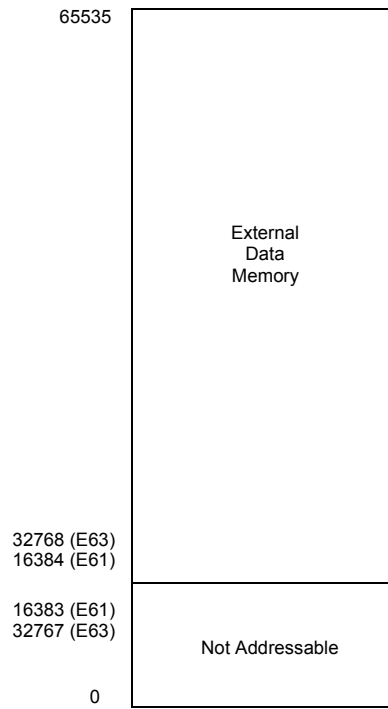

Figure 12. Data Memory Configuration



LOCATION		IDENTIFIERS	
R255	Stack Pointer (Bits 7-0)	SPL	
R254	Stack Pointer (Bits 15-8)	SPH	
R253	Register Pointer	RP	
R252	Program Control Flags	FLAGS	
R251	Interrupt Mask Register	IMR	
R250	Interrupt Request Register	IRQ	
R249	Interrupt Priority Register	IPR	
R248	Port 0-1 Mode	P01M	
R247	Port 3 Mode	P3M	
R246	Port 2 Mode	P2M	
R245	T0 Prescaler	PRE0	
R244	Timer/Counter0	T0	
R243	T1 Prescaler	PRE1	
R242	Timer/Counter1	T1	
R241	Timer Mode	TMR	
R240	Serial I/O	SIO	
R239	General Purpose Registers		
R4			
R3		Port 3	P3
R2		Port 2	P2
R1		Port 1	P1
R0	Port 0	P0	

Figure 13. Register File

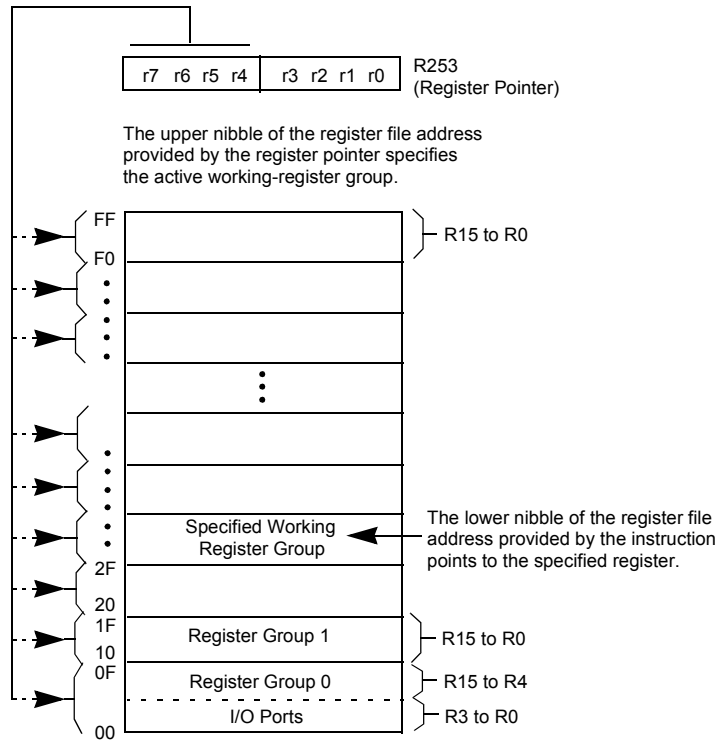

Figure 14. Register Pointer

FUNCTIONAL DESCRIPTION

Counter/Timers

There are two 8-bit programmable counter/timers (T0-T1), each driven by its own 6-bit programmable prescaler. The T1 prescaler is driven by internal or external clock sources; however, the T0 prescaler is driven by the internal clock only (Figure 15).

The 6-bit prescalers can divide the input frequency of the clock source by any integer number from 1 to 64. Each prescaler drives its counter, which decrements the value (1 to 256) that has been loaded into the counter. When both the counters and prescalers reach the end of the count, a timer interrupt request, IRQ4 (T0) or IRQ5 (T1), is generated.

The counter is programmed to start, stop, restart to continue, or restart from the initial value. The counters can also be programmed to stop upon reaching zero

(single pass mode) or to automatically reload the initial value and continue counting (modulo-n continuous mode).

The counter, but not the prescalers, are read at any time without disturbing their value or count mode. The clock source for T1 is user-definable and is either the internal microprocessor clock divided-by-four, or an external signal input through Port 3. The Timer Mode register configures the external timer input (P31) as an external clock, a trigger input that can be retriggerable or non-retriggerable, or as a gate input for the internal clock. Port 3 line P36 also serves as a timer output (TOUT) through which T0, T1, or the internal clock can be output. The counter/timers are cascaded by connecting the TO output to the input of T1.

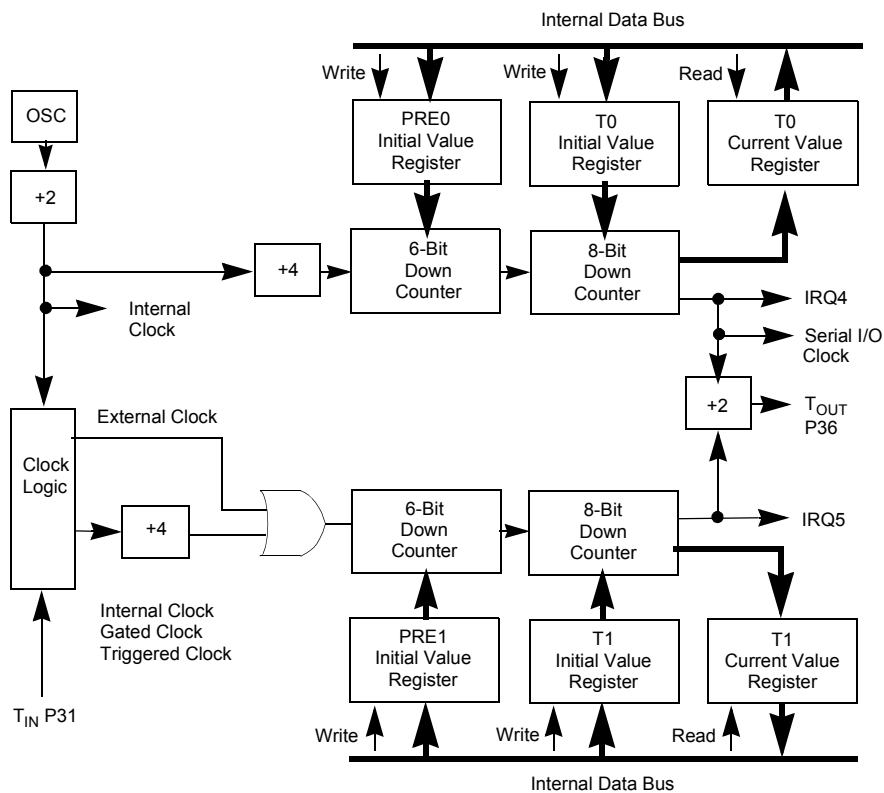

Figure 15. Counter/Timers Block Diagram

Interrupts

The Z86E61/E63 has six different interrupts from eight different sources. The interrupts are maskable and prioritized. The eight sources are divided as follows: four sources are claimed by Port 3 lines P33-P30, one in Serial Out, one in Serial In, and two in the counter/timers (Figure 16). The Interrupt Mask Register globally

or individually enables or disables the six interrupt requests. When more than one interrupt is pending, priorities are resolved by a programmable priority encoder that is controlled by the Interrupt Priority register (refer to Table 21 on page 16).

All Z86E61/E63 interrupts are vectored through locations in the program memory. When an interrupt machine cycle is activated, an interrupt request is granted. Thus, this disables all of the subsequent interrupts, saves the Program Counter and Status Flags, and then branches to the program memory vector location reserved for that interrupt. This memory location and the next byte contain the 16-bit address of the interrupt service routine for that particular interrupt request.

To accommodate polled interrupt systems, interrupt inputs are masked and the Interrupt Request register is polled to determine which of the interrupt requests need service. Software initialized interrupts are supported by setting the appropriate bit in the Interrupt Request Register (IRQ).

Internal interrupt requests are sampled on the falling edge of the last cycle of every instruction, and the interrupt request must be valid 5TpC before the falling edge of the last clock cycle of the currently executing instruction.

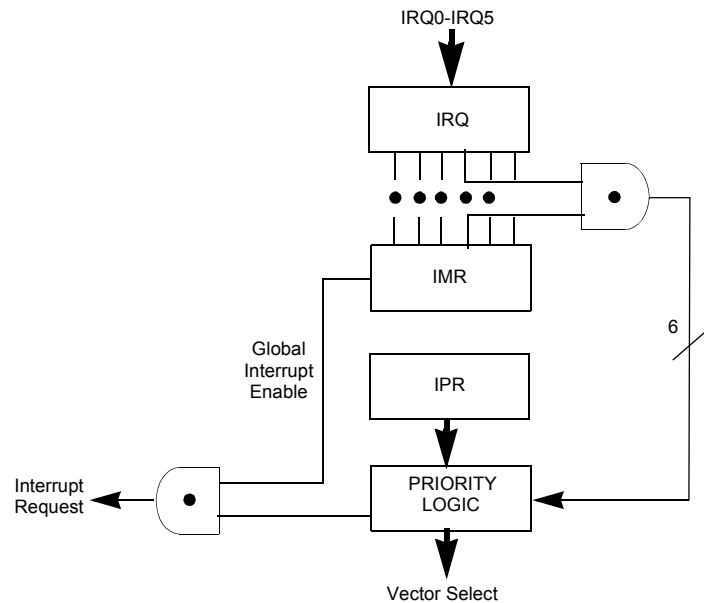

Figure 16. Interrupt Block Diagram

For the ROMless mode, when the device samples a valid interrupt request, the next 48 (external) clock cycles are used to prioritize the interrupt, and push the two PC bytes and the FLAG register on the stack. The following nine cycles are used to fetch the interrupt vector from external memory. The first byte of the interrupt service routine is fetched beginning on the 58th TpC cycle following the inter-

nal sample point, which corresponds to the 63rd TpC cycle following the external interrupt sample point.

Clock

The Z86E61/E63 on-chip oscillator has a high gain, parallel resonant amplifier for connection to a crystal, LC, ceramic resonator, or any suitable external clock source (XTAL1 = Input, XTAL2 = Output). The crystal should be AT cut, 1 MHz to 16 MHz max; series resistance (RS) is less than or equal to 100 Ohms. The crystal should be connected across XTAL1 and XTAL2 using the recommended capacitors ($10 \text{ pF} < C_L < 100 \text{ pF}$) from each pin to ground (Figure 17).

► **Note:** Actual capacitor value specified by crystal manufacturer.

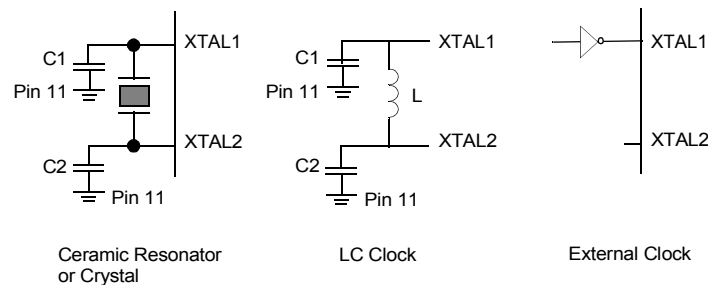

Figure 17. Oscillator Configuration

HALT

Turns off the internal CPU clock but not the XTAL oscillation. The counter/timers and external interrupts IRQ0, IRQ1, IRQ2, and IRQ3 remain active. The devices are recovered by interrupts, either externally or internally generated. An interrupt request must be executed (enabled) to exit HALT mode. After the interrupt service routine, the program continues from the instruction after the HALT.

STOP

This instruction turns off the internal clock and external crystal oscillation, and reduces the standby current to $5 \mu\text{A}$ (typical) or less. The STOP mode is terminated by a reset, which causes the processor to restart the application program at address 000Ch.

In order to enter STOP (or HALT) mode, it is necessary to first flush the instruction pipeline to avoid suspending execution in mid-instruction. To do this, the user



must execute a NOP (opcode = 0FFH) immediately before the appropriate SLEEP instruction. i.e.,

FF	NOP	; clear the pipeline
6F	STOP	; enter STOP mode
	or	
FF	NOP	; clear the pipeline
7F	HALT	; enter HALT mode

PROGRAMMING

Z86E61/E63 User Modes

The Z86E61/E63 uses separate AC timing cycles for the different User Modes available. Table 22 on page 27 shows the Z86E61/E63 User Modes. Table 23 on page 28 shows the timing of the programming waveforms.

User MODE 1 EPROM Read

The Z86E61 /E63 EPROM read cycle is provided so that the user may read the Z86E61 /E63 as a standard 27128 (E61) or 27256 (E63) EPROM. This is accomplished by driving the EPM pin (P32) to VH and activating \overline{CE} and \overline{OE} . PGM remains inactive. This mode is not valid after execution of an EPROM protect cycle. Timing for the EPROM read cycle is shown in Figure 18.

User MODE 2 EPROM Program

The Z86E61/E63 Program function conforms to the Intelligent programming algorithm. The device is programmed with V_{CC} , at 6.0V and $V_{PP} = 12.5V$. Programming pulses are applied in 1 ms increments to a maximum of 25 pulses before proper verification. After verification, a programming pulse of three times the duration of the cycles necessary to program the device is issued to ensure proper programming. After all addresses are programmed, a final data comparison is executed and the programming cycle is complete. Timing for the Z86E61/E63 programming cycle is shown in Figure 18.

User Mode 3: PROM Verify

The Program Verify cycle is used as part of the intelligent programming algorithm to insure data integrity under worst-case conditions. It differs from the EPROM Read cycle in that V_{pp} is active and V_{CC} must be driven to 6.0V. Timing is shown in Figure 18.



User Modes 4 and 5: EPROM and RAM Protect

To extend program security, EPROM and RAM protect cycles are provided for the Z86E61/E63. Execution of the EPROM protect cycle prohibits proper execution of the EPROM Read, EPROM Verify, and EPROM programming cycles. Execution of the RAM protect cycle disables accesses to the upper 128 bytes of register memory (excluding mode and configuration registers), but first the user's program must set bit 6 of the IMR (R251). Timing is shown in Figure 20 and Figure 21.

User Modes. Table 6 shows the programming voltage of each mode of the Z86E61/E63.

Table 22. OTP Programming^a

User/Test Mode Device Pin No.	Device Pins						Port 1 CNFG Data	
	P33	P32	P30	P31	P20			
User Modes	V _{PP}	EPM	CE	OE	PGM	ADDR	V _{CC}	
EPROM Read	V _{IH}	V _H ^c	V _{IL} ^d	V _{IL}	V _{IH}	Addr	5.0V	Out
Program	V _{PP} ^b	X	V _{IL}	V _{IH} ^e	V _{IL}	Addr	6.0V	In
Program Verify	V _{PP} ^b	X	V _{IL}	V _{IL}	V _{IH}	Addr	6.0V	Out
EPROM Protect	V _{PP} ^b	V _H	V _H	V _{IH}	V _{IL}	XX ^f	6.0V	XX
RAM Protect	V _{PP}	X	V _H	V _{IH}	V _{IL}	XX ^f	6.0V	XX

- a. I_{PP} during programming = 40 mA maximum.
I_{CC} during programming, verify, or read = 40 mA maximum.
- b. V_{PP} = 12.0 ± 0.5 V.
- c. V_H = 12.0 ± 0.5 V
- d. V_{IL} = 0 V
- e. V_{IH} = 5 V.
- f. XX = Irrelevant.

Z86E63 Signal Description for EPROM Program/Read

The following signals are required to correctly program or read the Z86E63 device.

ADDR

The address must remain stable throughout the program read cycle.

DATA

The I/O data bus must be stable during programming ($\overline{\text{OE}}$ High, $\overline{\text{PGM}}$ Low, V_{PP} High). During read the data bus outputs data.



XCLK

A clock is required to clock the $\overline{\text{RESET}}$ signal into the registers before programming.

A constant clock can be applied, or the XCLK input can be toggled a minimum of 12 cycles before any programming or verify function begins. The maximum clock frequency to be applied when in the EPROM mode is 12 MHz.

$\overline{\text{RESET}}$

The reset input can be held to a constant Low or High value throughout normal programming. It must be held High to program the EPROM protect option bit. Also, any time the $\overline{\text{RESET}}$ input changes state the XCLK must be clocked a minimum of 12 times to clock the $\overline{\text{RESET}}$ through the reset filter.

$\overline{\text{OE}}$

When the device is placed in EPROM mode, the $\overline{\text{OE}}$ input also serves as the precharge for the sense amp. The precharge signal should be Low for the first half of the stable address and High for the second half. The PRECHG signal is inverted from the $\overline{\text{OE}}$ signal so the $\overline{\text{OE}}$ should be High on the first half and Low on the second half, or stable address. The EPROM output data should be sampled during the second half of stable address.

The access time of the EPROM is defined in later sections. This two part calculation of access time is required because this is a precharged sense amp with a precharge clock.

Table 23. Timing of Programming Waveforms

Parameters	Name	Min	Max	Units
1	Address Setup Time	2		μs
2	Data Setup Time	2		μs
3	V_{PP} Setup	2		μs
4	V_{CC} Setup Time	2		μs
5	Chip Enable Setup Time	2		μs
6	Program Pulse Width	0.95		ms
7	Data Hold Time	2		μs
8	$\overline{\text{OE}}$ Setup Time	2		μs
9	Data Access Time		200	ns
10	Data Output Float Time		100	ns



Table 23. Timing of Programming Waveforms (Continued)

Parameters	Name	Min	Max	Units
11	Over program Pulse Width	2.85		ms
12	EPM Setup Time	2		μ s
13	$\overline{\text{PGM}}$ Setup Time	2		μ s
14	Address to $\overline{\text{OE}}$ Setup Time	2		μ s
15	Option Program Pulse Width	78		ms

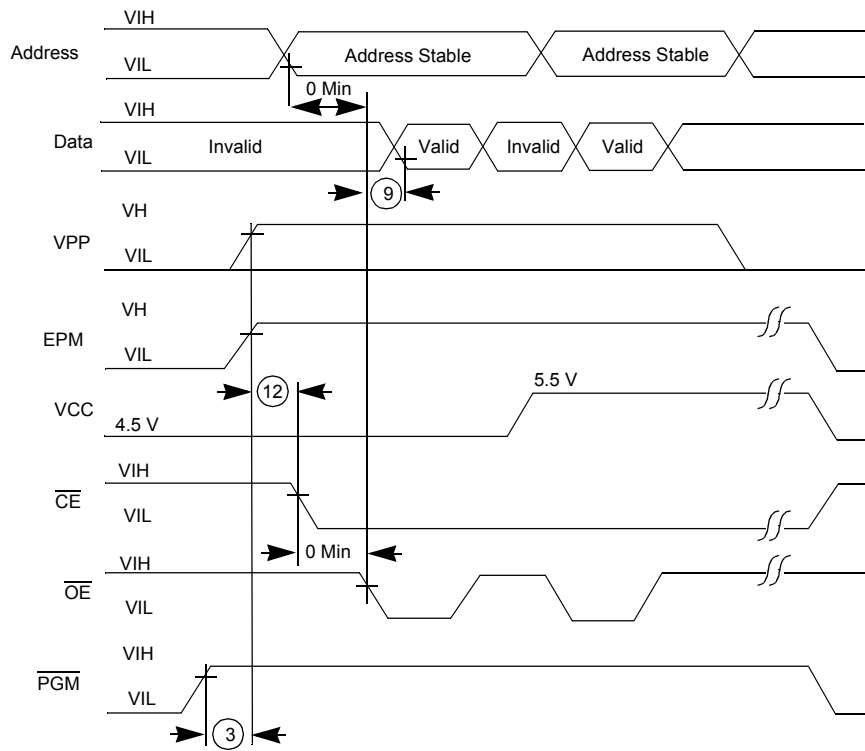

Figure 18. EPROM Read

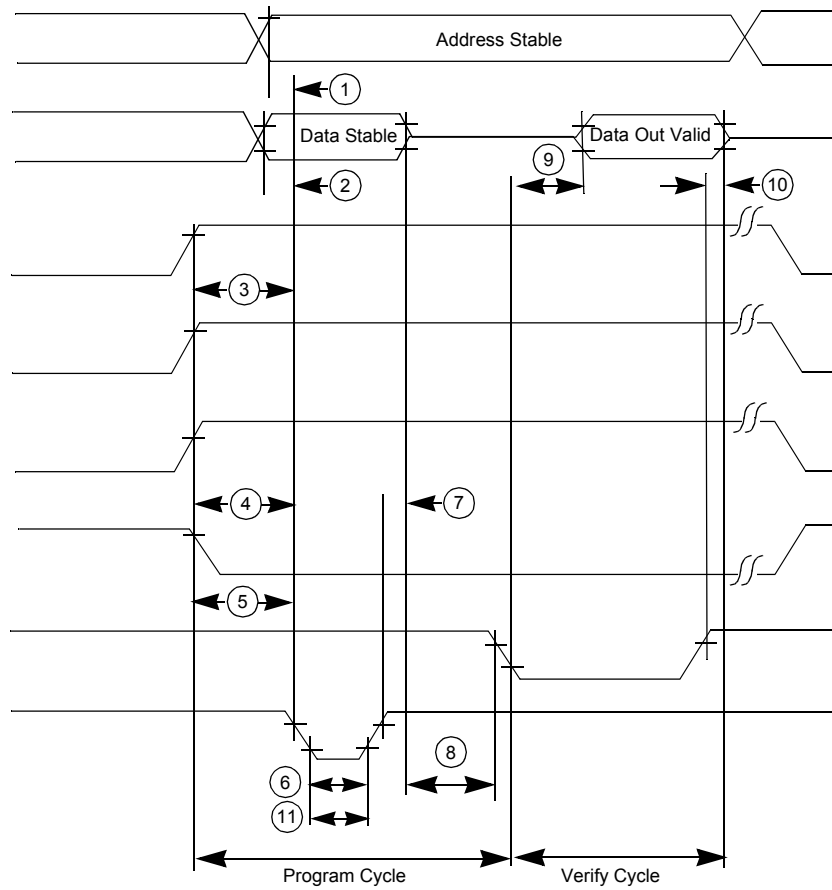

Figure 19. EPROM Program and Verity

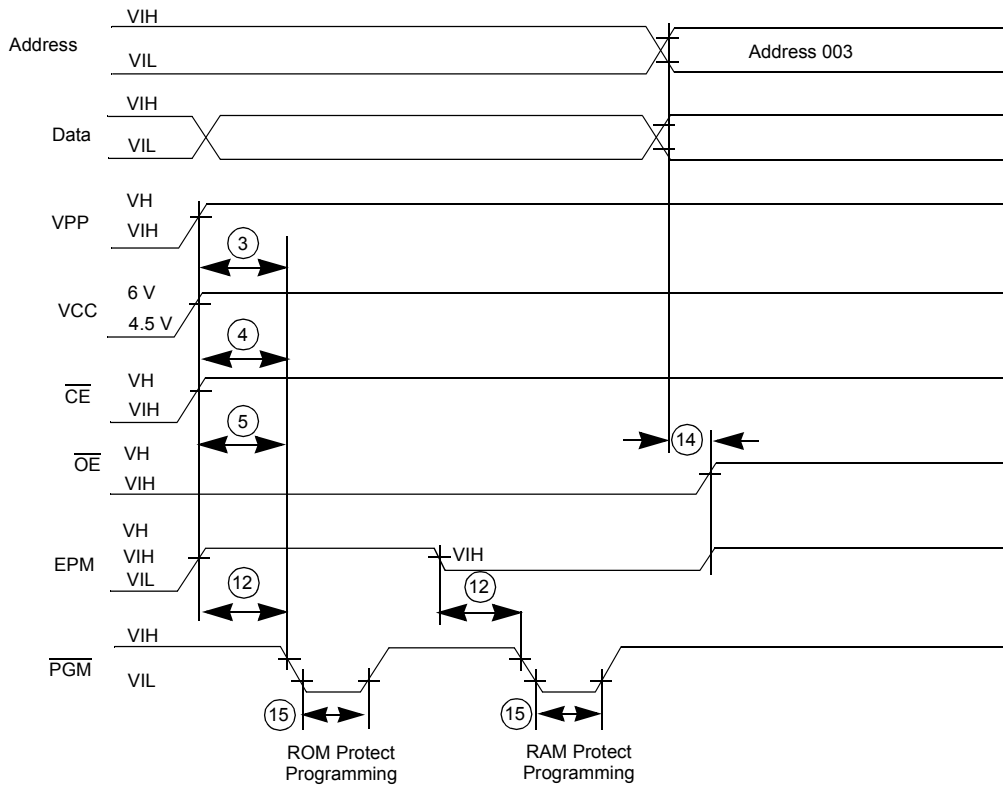

Figure 20. Programming EPROM, RAM Protect, and 4K Size Selection

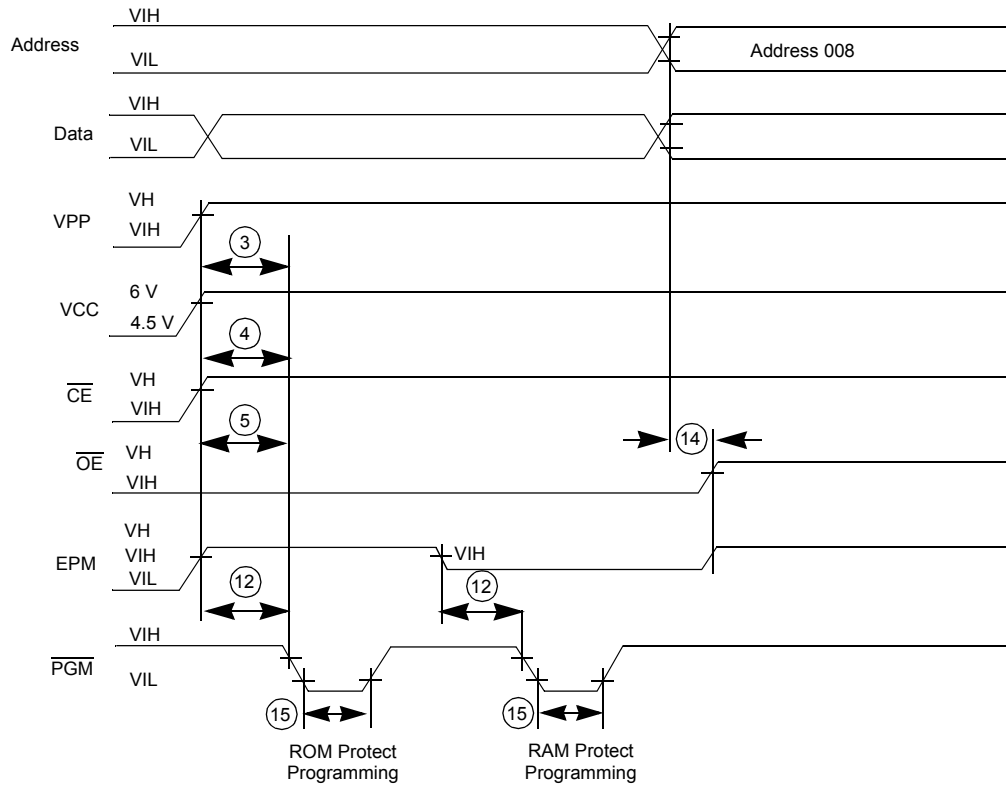

Figure 21. Programming EPROM, RAM Protect, and 16K Size Selection

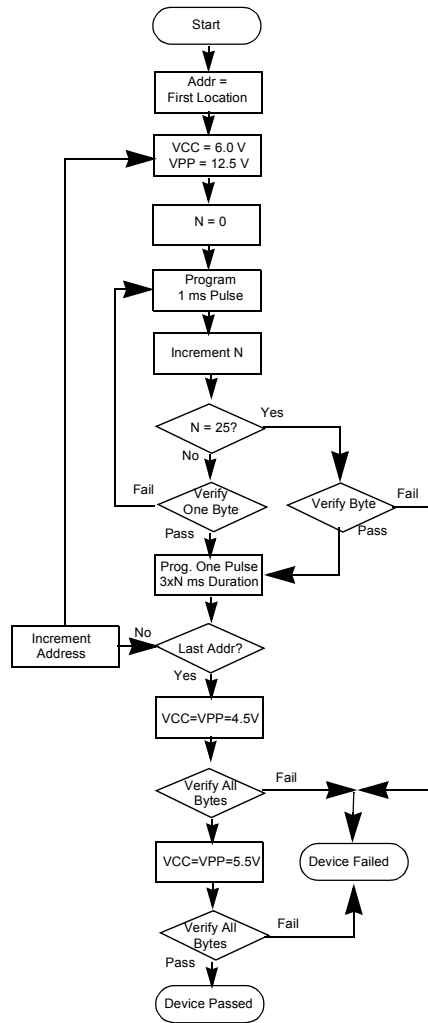

Figure 22. Intelligent Programming Flowchart

ABSOLUTE MAXIMUM RATINGS

Table 24. Absolute Maximum Ratings

Symbol	Description	Min	Max	Units
V_{CC}	Supply Voltage ^a	-0.3	+ 7.0	V
T_{STG}	Storage Temp	-65	+150	°C



Table 24. Absolute Maximum Ratings (Continued)

Symbol	Description	Min	Max	Units
T_A	Operating Ambient Temperature		Note ^b	°C

- a. Voltages on all pins with respect to GND.
- b. See See "ORDERING INFORMATION" on page 62.

Stresses greater than those listed under Absolute Maximum Ratings may cause permanent damage to the device. This is a stress rating only; operation of the device at any condition above those indicated in the operational sections of these specifications is not implied. Exposure to absolute maximum rating conditions for an extended period may affect device reliability.

STANDARD TEST CONDITIONS

The characteristics listed below apply for standard test conditions as noted. All voltages are referenced to GND. Positive current flows into the referenced pin (Figure 23).

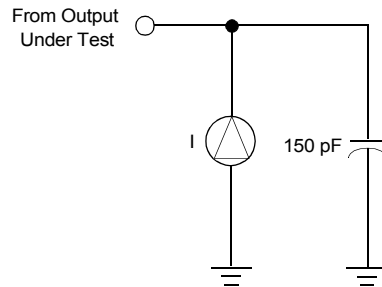

Figure 23. Test Load Diagram



DC CHARACTERISTICS

Table 25. DC Characteristics

Sym	Parameter	$T_A = 0\text{ }^\circ\text{C to }+70\text{ }^\circ\text{C}$		Typical @ 25 °C	Units	Conditions
		Min	Max			
	Max Input Voltage		7		V	$I_{IN} = 250\text{ }\mu\text{A}$
	Max Input Voltage		13		V	P33-P30 Only
V_{CH}	Clock Input High Voltage	3.8	$V_{CC} + 0.3$		V	Driven by External Clock Generator
V_{CL}	Clock Input Low Voltage	-0.3	0.8		V	Driven by External Clock Generator
V_{IH}	Input High Voltage	2.0	$V_{CC} + 0.3$		V	
V_{IL}	Input Low Voltage	-0.3	0.8		V	
V_{OH}	Output High Voltage	2.4			V	$I_{OH} = -2.0\text{ mA}$
V_{OL}	Output Low Voltage		0.4		V	$I_{OL} = +2.0\text{ mA}$
V_{RH}	Reset Input High Voltage	3.8	$V_{CC} + 0.3$		V	
V_{RI}	Reset Input Low Voltage	-0.3	0.8		V	
I_{IL}	Input Leakage	-10	10		μA	0 V $V_{IN} + 5.25\text{ V}$
I_{OL}	Output Leakage	-10	10		μA	0 V $V_{IN} + 5.25\text{ V}$
I_{IR}	Reset Input Current		-50		μA	$V_{CC} = +5.25\text{ V}$, $V_{RL} = 0\text{ V}$
I_{CC}	Supply Current		50	25	mA	@ 16 MHz
			60	35	mA	@ 20 MHz
I_{CC1}	Standby Current		15	5	mA	HALT Mode $V_{IN} = 0\text{ V}$, V_{CC} @ 16 MHz
			20	10	mA	HALT Mode $V_{IN} = 0\text{ V}$, V_{CC} @ 20 MHz
I_{CC2}^a	Standby Current		20	5	μA	STOP Mode $V_{IN} = 0\text{ V}$, V_{CC} @ 16 MHz
			20	5	μA	STOP Mode $V_{IN} = 0\text{ V}$, V_{CC} @ 20 MHz

- a. ICC2 requires loading TMR (F1Hh) with any value prior to STOP execution.
Use this sequence:
LD TMR,#00
NOP
STOP

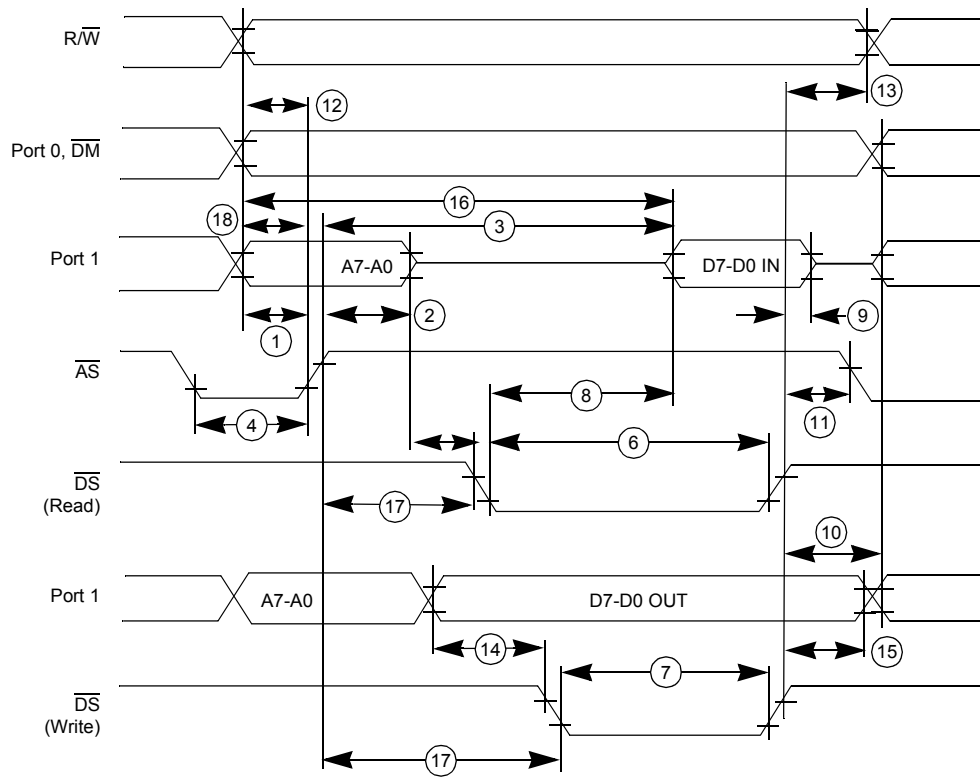

Figure 24. External I/O or Memory Read/Write Timing



AC CHARACTERISTICS

Table 26. External I/O or Memory Read and Write Timing

No	Symbol	Parameter	TA = 0°C to +70°C				Units	Notes
			16 MHz ^a		20 MHz			
			Min	Max	Min	Max		
1	TdA(AS)	Address Valid to \overline{AS} Rise Delay	20		26		ns	Note ^{b,c}
2	TdAS(A)	\overline{AS} Rise to Address Float Delay	30		28		ns	Note ^{b,c}
3	TdAS(DR)	\overline{AS} Rise to Read Data Req'd Valid		180		160	ns	Note ^{b,c,d}
4	TwAS	\overline{AS} Low Width	35		36		ns	Note ^{b,c}
5	TdAZ(DS)	Address Float to \overline{DS} Fall	0		0		ns	
6	TwDSR	\overline{DS} (Read) Low Width	135		130		ns	Note ^{b,c,d}
7	TwDSW	\overline{DS} (Write) Low Width	80		75		ns	Note ^{b,c,d}
8	TdDSR(DR)	\overline{DS} Fall to Read Data Req'd Valid		75		100	ns	Note ^{b,c,d}
9	ThDR(DS)	Read Data to \overline{DS} Rise Hold Time	0		0		ns	Note ^{b,c}
10	TdDS(A)	\overline{DS} Rise to Address Active Delay	35		48		ns	Note ^{b,c}
11	TdDS(AS)	\overline{DS} Rise to \overline{AS} Fall Delay	30		36		ns	Note ^{b,c}
12	TdR/W(AS)	R/W Valid to \overline{AS} Rise Delay	20		32		ns	Note ^{b,c}
13	TdDS(R/W)	\overline{DS} Rise to R/W Not Valid	30		36		ns	Note ^{b,c}
14	TdDW(DSW)	Write Data Valid to \overline{DS} Fall (Write) Delay	25		40		ns	Note ^{b,c}
15	TdDS(DW)	\overline{DS} Rise to Write Data Not Valid Delay	30		40		ns	Note ^{b,c}
16	TdA(DR)	Address Valid to Read Data Req'd Valid		200		200	ns	Note ^{b,c,d}
17	TdAS(DS)AS	AS Rise to \overline{DS} Fall Delay	40		48		ns	Note ^{b,c}
18	TdDM(AS)	\overline{DM} Valid to \overline{AS} Fall Delay	30		36		ns	Note ^{b,c}

- a. All timing references use 2.0V for a logic 1 and 0.8V for a logic 0.
- b. Timing numbers given are for minimum TpC.
- c. See Table 11
- d. When using extended memory timing add 2 TpC.



Table 27. Clock Dependent Formulas

Number	Symbol	Equation
1	TdA(AS)	$0.40 T_{pC} + 0.32$
2	TdAS(A)	$0.59 T_{pC} - 3.25$
3	TdAS(DR)	$2.83 T_{pC} + 6.14$
4	TwAS	$0.66 T_{pC} - 1.65$
6	TwDSR	$2.33 T_{pC} - 10.56$
7	TwDSW	$1.27 T_{pC} + 1.67$
8	TdDSR(DR)	$1.97 T_{pC} - 42.5$
10	TdDS(A)	$0.8 T_{pC}$
11	TdDS(AS)	$0.59 T_{pC} - 3.14$
12	TdR/W(AS)	$0.4 T_{pC}$
13	TdDS(R/W)	$0.8 T_{pC} - 15$
14	TdDW(DSW)	$0.4 sT_{pC}$
15	TdDS(DW)	$0.88 T_{pC} - 19$
16	TdA(DR)	$4 T_{pC} - 20$
17	TdAS(DS)	$0.91 T_{pC} - 10.7$
18	TdDM(AS)	$0.9 T_{pC} - 26.3$

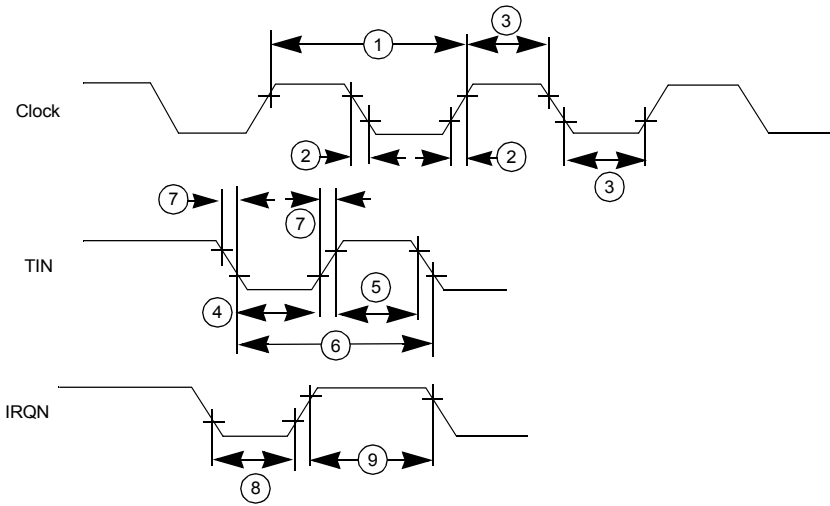

Figure 25. Additional Timing



AC CHARACTERISTICS

Table 28. Additional Timing

No	Symbol	Parameter	TA = 0°C to +70°C				Units	Notes
			16 MHz		20 MHz			
			Min	Max	Min	Max		
1	TpC	Input Clock Period	62.5	1000	50	1000	ns	Note ^a
2	TrC, TfC	Clock Input Rise & Fall Times		10		15	ns	Note ^a
3	TwC	Input Clock Width	21		37		ns	Note ^a
4	TwTinL	Timer Input Low Width	50		75		ns	Note ^b
5	TwTinH	Timer Input High Width	5TpC		5TpC			Note ^b
6	TpTin	Timer Input Period	8TpC		8TpC			Note ^b
7	TrTin, TfTin	Timer Input Rise & Fall Times	100		100		ns	Note ^b
8A	TwIL	Interrupt Request Input Low Times	70		50		ns	Note ^{b,c}
8B	TwIL	Interrupt Request Input Low Times	5TpC		5TpC			Note ^{b,d}
9	TwIH	Interrupt Request Input High Times	5TpC		5TpC			Note ^{b,e}

- a. Clock timing references use 3.8V for a logic 1 and 0.8V for a logic 0.
- b. Timing references use 2.0V for a logic 1 and 0.8V for a logic 0.
- c. Interrupt request through Port 3 (P33-P31).
- d. Interrupt request through Port 30.
- e. Interrupt references request through Port 3.

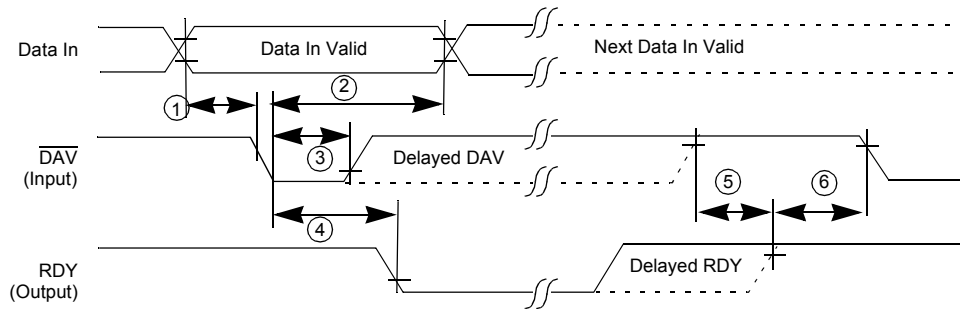

Figure 26. Input Handshake Timing

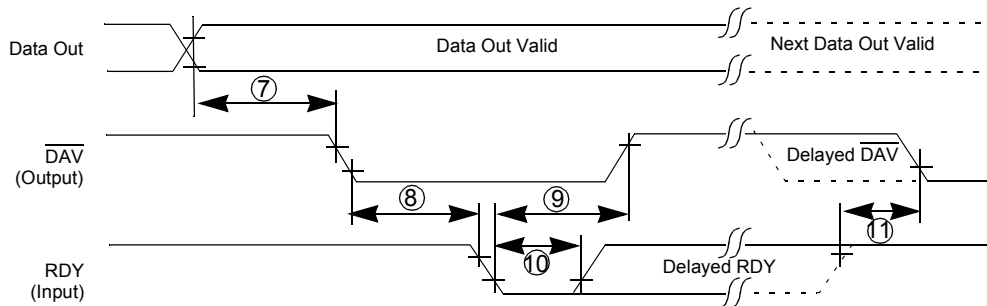

Figure 27. Output Handshake Timing

Table 29. Handshake Timing

No	Symbol	Parameter	$T_A = 0^\circ\text{C to } +70^\circ\text{C}$				Data Direction
			16 MHz		20 MHz		
			Min	Max	Min	Max	
1	TsDI(DAV)	Data In Setup Time	0	0			IN
2	ThDI(DAV)	Data In Hold Time	145	145			IN
3	TwDAV	Data Available Width	110	110			IN
4	TdDAVI(RDY)	DAV Fall to RDY Fall Delay		115		115	IN
5	TdDAVId(RDY)	DAV Rise to RDY Rise Delay		115		115	IN
6	TdRDY0(DAV)	RDY Rise to DAV Fall Delay	0	0			IN
7	TdD0(DAV)	Data Out to DAV Fall Delay		TpC		TpC	OUT



Table 29. Handshake Timing (Continued)

No	Symbol	Parameter	$T_A = 0^\circ\text{C to } +70^\circ\text{C}$				Data Direction
			16 MHz		20 MHz		
			Min	Max	Min	Max	
8	TdDAV0(RDY)	DAV Fall to RDY Fall Delay	0		0		OUT
9	TdRDY0(DAV)	RDY Fall to DAV Rise Delay		115		115	OUT
10	TwRDY	RDY Width	110		110		OUT
11	TdRDY0d(DAV)	RDY Rise to DAV Fall Delay		115		115	OUT

Z8 CONTROL REGISTER DIAGRAMS

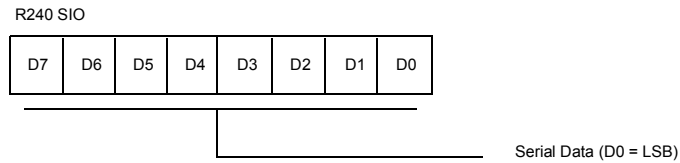

Figure 28. Serial I/O Register (F0_H: Read/Write)

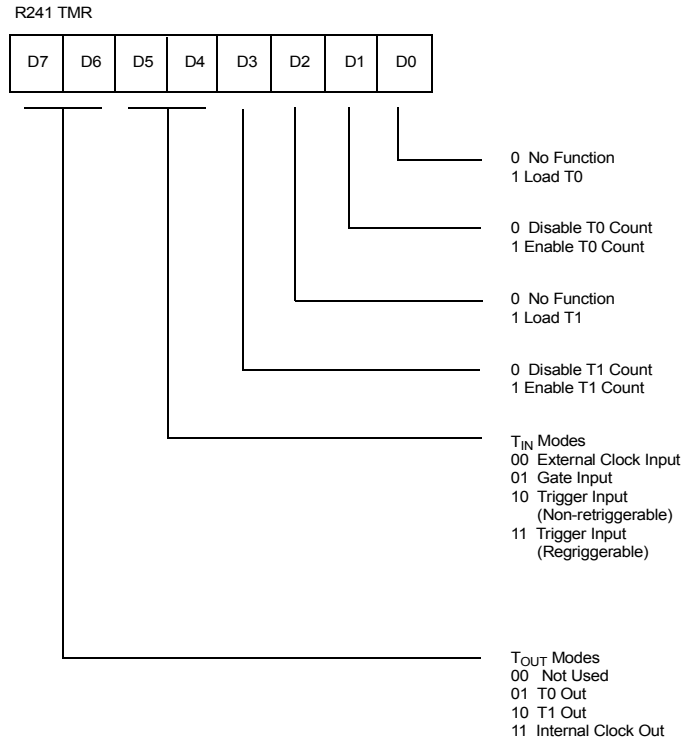

Figure 29. Timer Mode Register (F1_H: Read/Write)

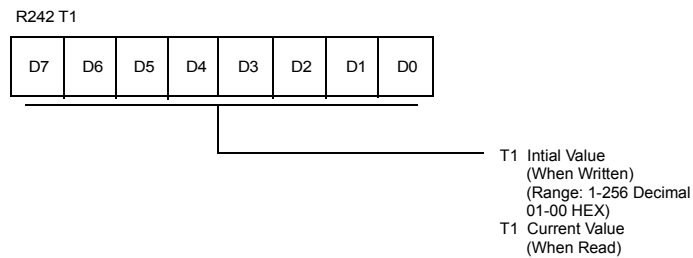

Figure 30. Counter/Timer 1 Register (F2_H: Read/Write)

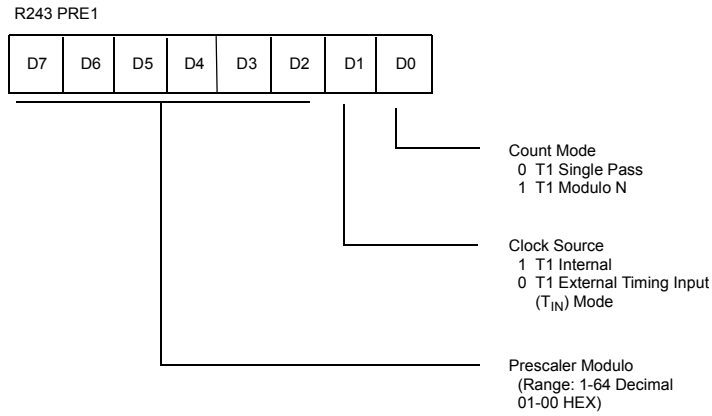

Figure 31. Prescaler 1 Register (F3_H: Write Only)

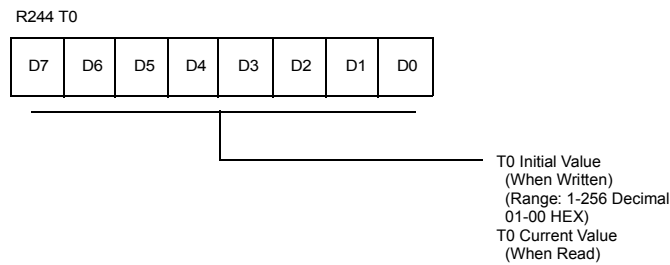

Figure 32. Counter/Timer 0 Register (F4_H: Read/Write)

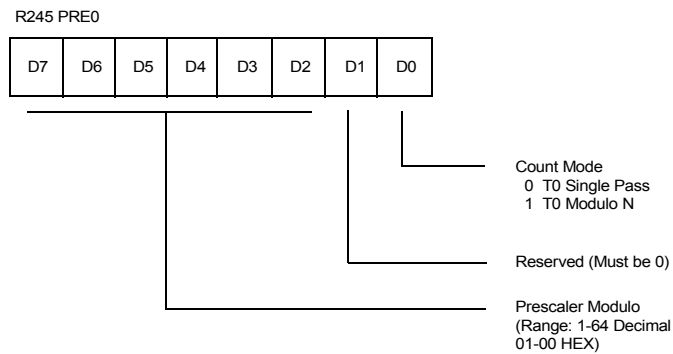

Figure 33. Prescaler 0 Register (F5_H: Write Only)

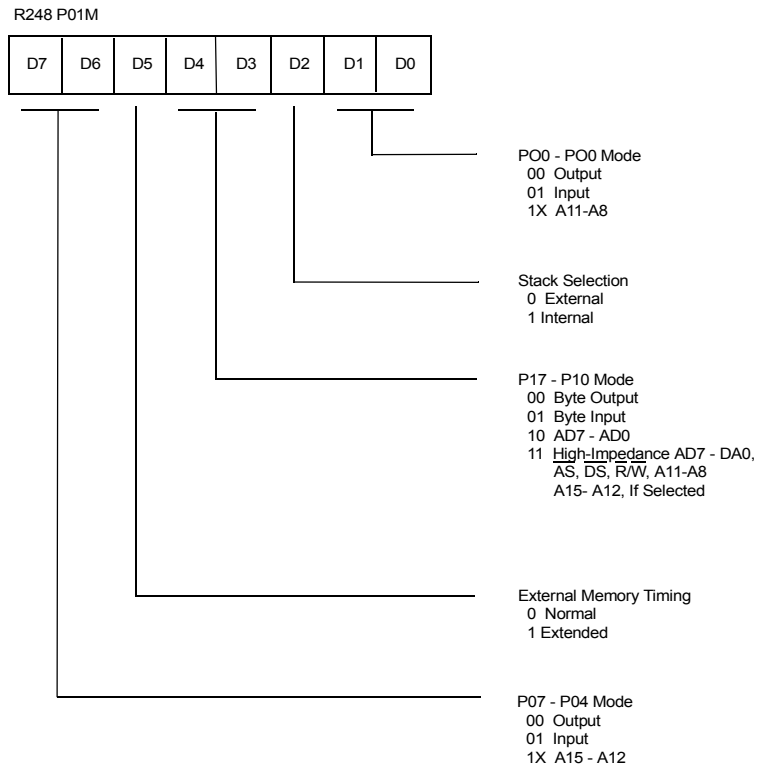

Figure 36. Port 0 and 1 Mode Register (F8_H: Write Only)

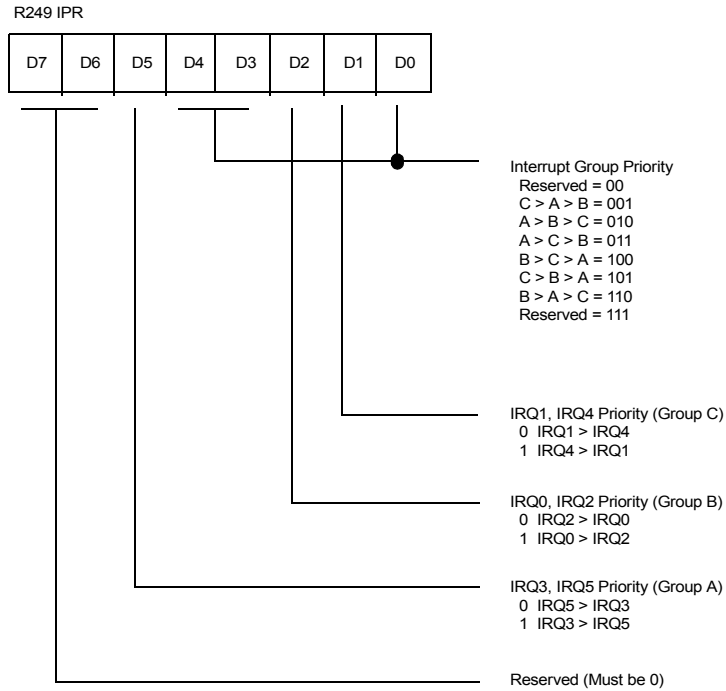

Figure 37. Interrupt Priority Register (F9_H: Write Only)

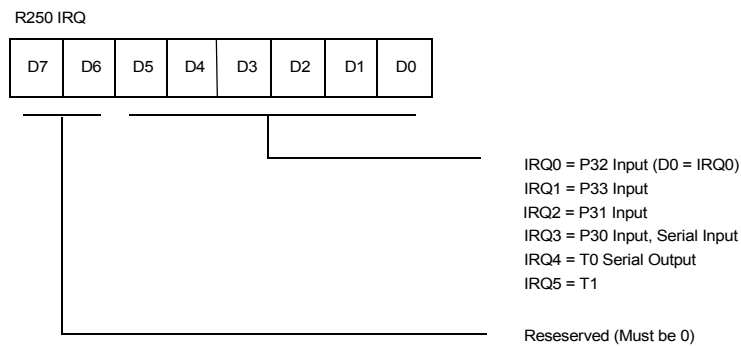

Figure 38. Interrupt Request Register (FA_H: Read/Write)

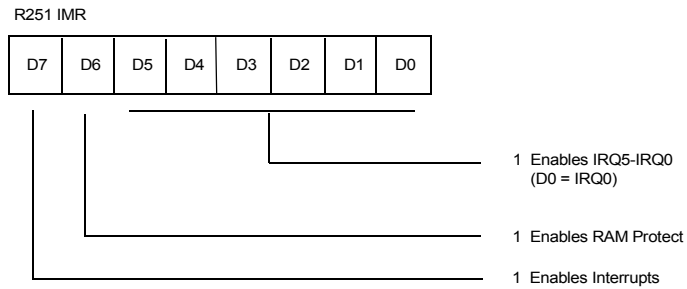

Figure 39. Interrupt Mask Register (FB_H: Read/Write)

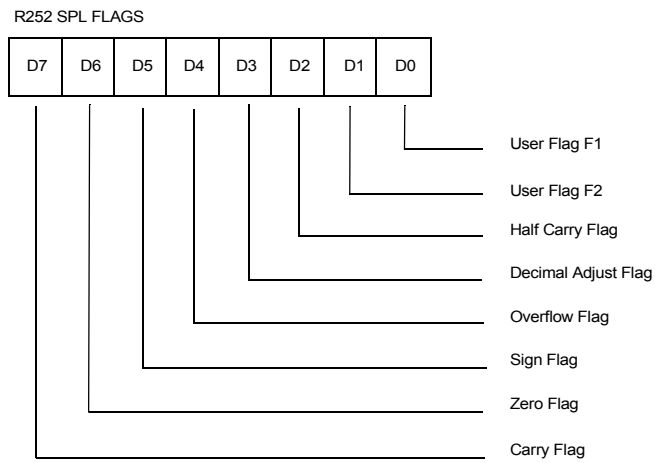

Figure 40. Flag Register (FC_H: Read/Write)

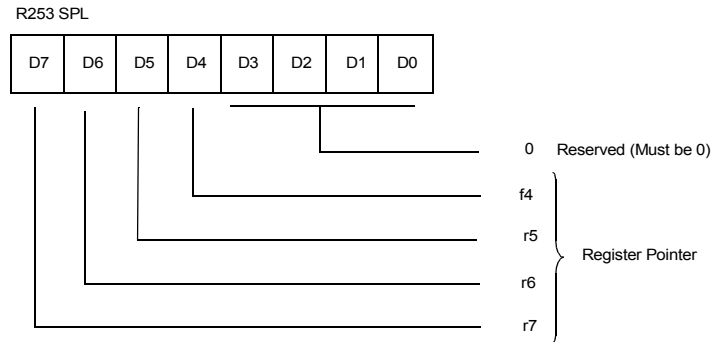

Figure 41. Register Pointer Register (FD_H: Read/Write)

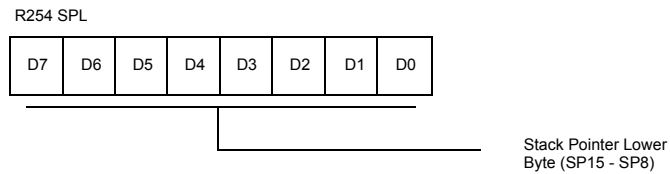

Figure 42. Stack Pointer Register (FE_H: Read/Write)

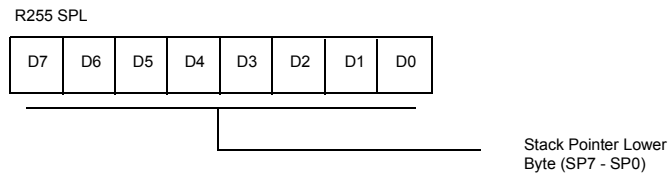

Figure 43. Stack Pointer Register (FF_H: Read/Write)



DC CHARACTERISTICS

Supply Current

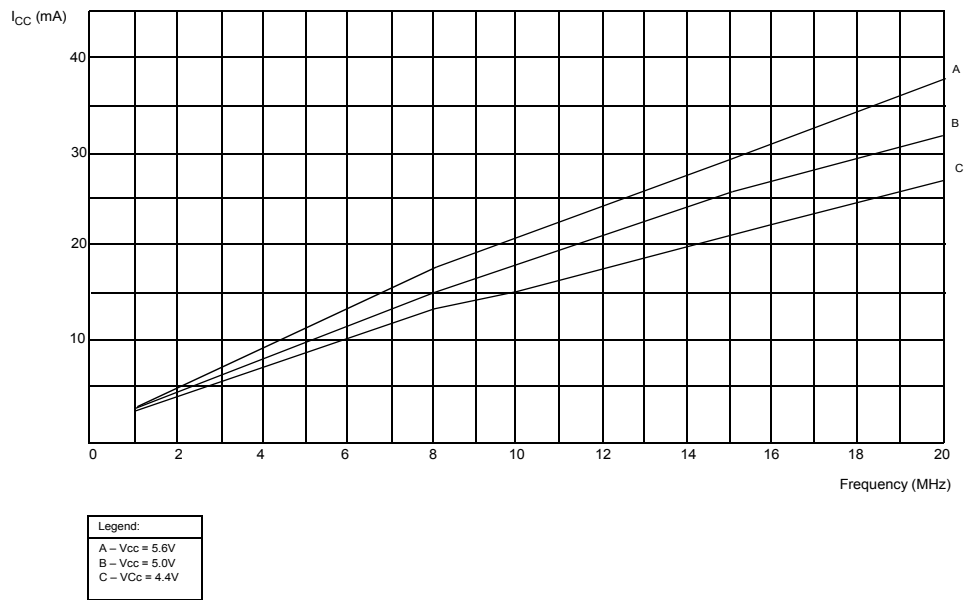

Figure 44. Typical I_{CC} vs. Frequency



Standby Current

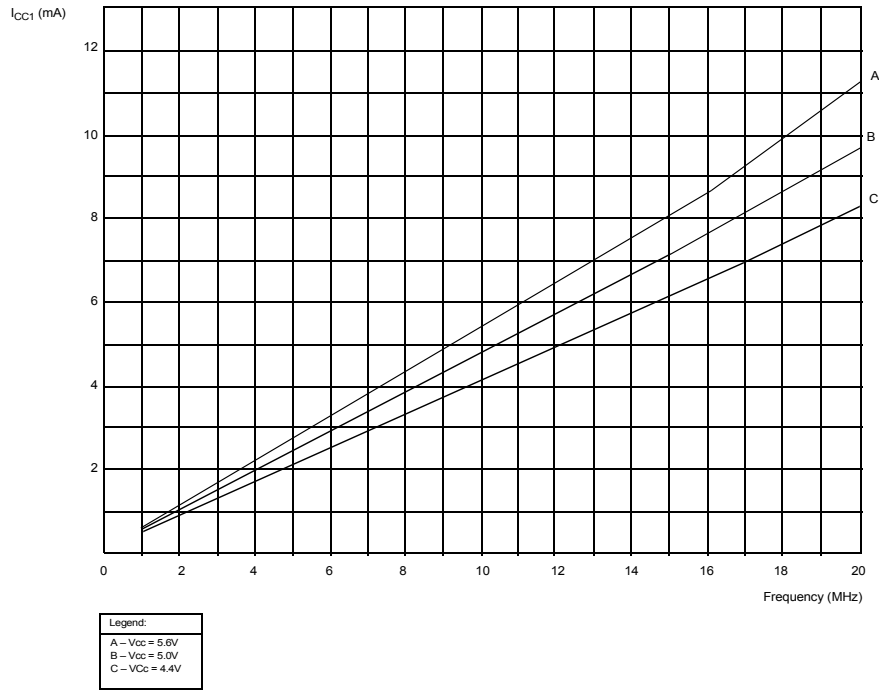

Figure 45. Typical I_{CC1} vs. Frequency



INSTRUCTION SET NOTATION

Addressing Modes. The following notation is used to describe the addressing modes and instruction operations as shown in the instruction summary (Table 14).

Table 30. Instruction Set Notation

Symbol	Meaning
IRR	Indirect register pair or indirect working register pair address
Irr	Indirect working register pair only
X	Indexed address
DA	Direct address
RA	Relative address
IM	Immediate
R	Register or working register address
r	Working register address only
IR	Indirect register or indirect working register address
Ir	Indirect working register address only
RR	Register pair or working register pair address

Symbols. The following symbols are used in describing the instruction set.

Symbol	Meaning
dst	Destination location or contents
src	Source location or contents
cc	Condition Code
@	Indirect address prefix
SP	Stack Pointer
PC	Program Counter
FLAGS	Flag Register (Control Register 252)
RP	Register Pointer (R253)
IMR	Interrupt Mask Register (R251)



Flags. Control register (R252) contains the following six flags:

Symbol	Meaning
C	Carry flag
Z	Zero flag
S	Sign flag
V	Overflow flag
D	Decimal-adjust flag
H	Half-carry flag

Affected flags are indicated by:

Symbol	Meaning
0	Clear to zero
1	Set to one
*	Set to clear according to operation
-	Unaffected
x	Undefined

CONDITION CODES

Table 31. Condition Codes

Value	Mnemonic	Meaning	Flags Set
1000		Always True	
0111	C	Carry	C = 1
1111	NC	No Carry	C = 0
0110	Z	Zero	Z = 1
1110	NZ	Not Zero	Z = 0
1101	PL	Plus	S = 0
0101	MI	Minus	S = 1
0100	OV	Overflow	V = 1
1100	NOV	No Overflow	V = 0
0110	EQ	Equal	Z = 1
1110	NE	Not Equal	Z = 0
1001	GE	Greater Than or Equal	(S XOR V) = 0



Table 31. Condition Codes (Continued)

Value	Mnemonic	Meaning	Flags Set
0001	LT	Less than	$(S \text{ XOR } V) = 1$
1010	GT	Greater Than	$[Z \text{ OR } (S \text{ XOR } V)] = 0$
0010	LE	Less Than or Equal	$[Z \text{ OR } (S \text{ XOR } V)] = 1$
1111	UGE	Unsigned Greater Than or Equal	$C = 0$
0111	ULT	Unsigned Less Than	$C = 1$
1011	UGT	Unsigned Greater Than	$(C = 0 \text{ AND } Z = 0) = 1$
0011	ULE	Unsigned Less Than or Equal	$(C \text{ OR } Z) = 1$
0000	F	Never True (Always False)	



INSTRUCTION FORMATS

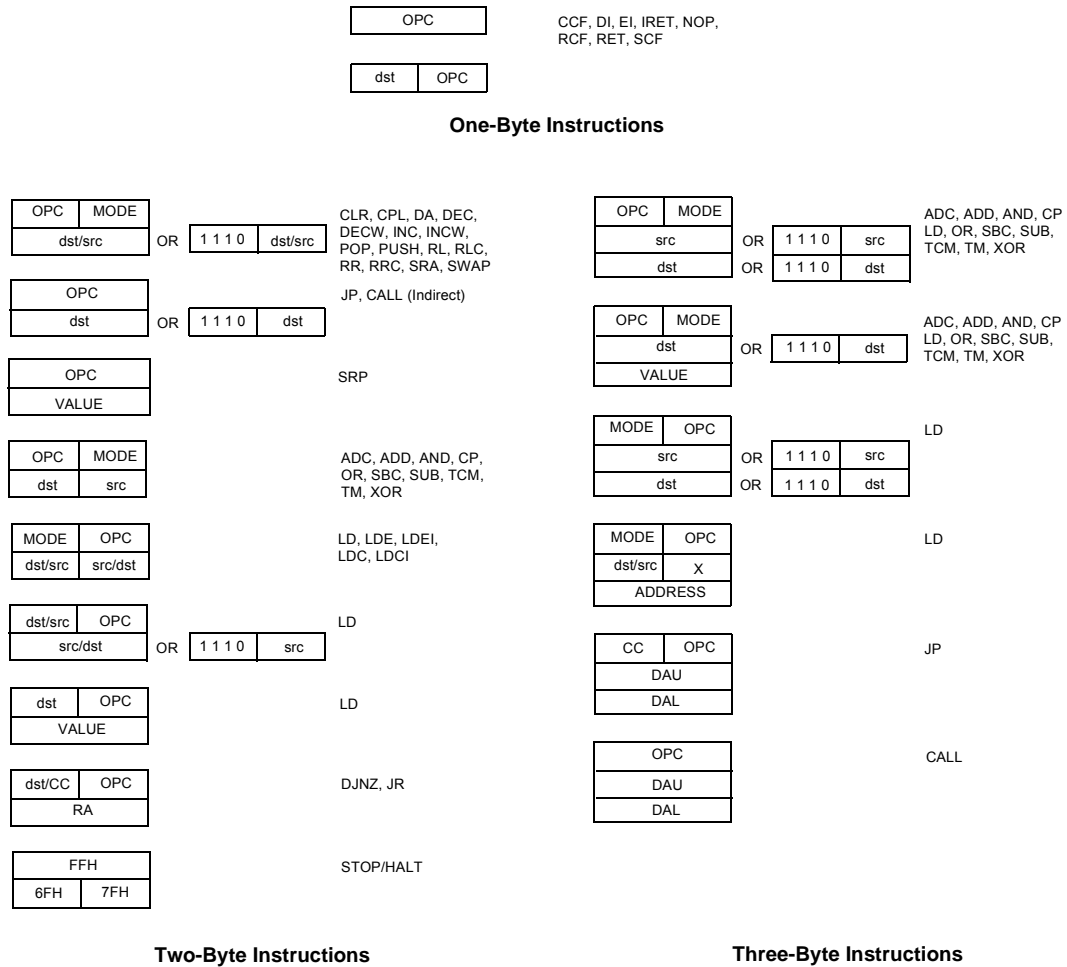

Figure 46. Instruction Formats



INSTRUCTION SUMMARY

Note: Assignment of a value is indicated by the symbol “←”. For example:

$dst \leftarrow dst + src$

indicates that the source data is added to the destination data and the result is stored in the destination location. The notation “addr (n)” is used to refer to bit (n) of a given operand location. For example:

$dst (7)$

refers to bit 7 of the destination operand

Table 32. Instruction Summary

Instruction and Operation	Address Mode		Opcode Byte (Hex)	Flags Affected					
	dst	src		C	Z	S	V	D	H
ADC dst, src $dst \leftarrow dst + src + C$	Note ^a		1[]	*	*	*	*	0	*
ADD dst, src $dst \leftarrow dst + src$	Note ^a		0[]	*	*	*	*	0	*
AND dst, src $dst \leftarrow dst \text{ AND } src$	Note ^a		5[]	-	*	*	0	-	-
CALL dst $SP \leftarrow SP - 2$ $@SP \leftarrow PC,$ $PC \leftarrow dst$	DA IRR		06 D4	-	-	-	-	-	-
CCF $C \leftarrow \text{NOT } C$			EF	*	-	-	-	-	-
CLR dst $dst \leftarrow 0$	R IR		B0 B11	-	-	-	-	-	-
COM dst $dst \leftarrow \text{NOT } dst$	R IR		60 61	-	*	*	0	-	-
CP dst, src $dst - src$	Note ^a		A[]	*	*	*	*	-	-
DA dst $dst \leftarrow DA \text{ dst}$	R IR		40 41	*	*	*	X	-	-



Table 32. Instruction Summary (Continued)

Instruction and Operation	Address Mode		Opcode Byte (Hex)	Flags Affected					
	dst	src		C	Z	S	V	D	H
DEC dst	R		00	-	*	*	*	-	-
dst ← dst - 1	IR		01						
DECW dst	RR		80	-	*	*	*	-	-
dst ← dst - 1	IR		81						
DI			8F	-	-	-	-	-	-
IMR(7) ← 0									
DJNZ r, dst	RA		rA	-	-	-	-	-	-
r ← r - 1			r = 0 - F						
if r ≠ 0									
PC ← PC + dst									
Range: +127, -128									
EI			9F	-	-	-	-	-	-
IMR(7) ← 1									
HALT			7F	-	-	-	-	-	-
INC dst	r		rE	-	*	*	*	-	-
dst ← dst + 1			r = 0 - F						
	R		20						
	IR		21						
INCW dst	RR		A0	-	*	*	*	-	-
dst ← dst + 1	IR		A1						
IRET			BF	*	*	*	*	*	*
FLAGS ← @SP;									
SP ← SP + 1									
PC ← @SP;									
SP ← SP + 2;									
IMR(7) ← 1									
JP cc, dst	DA		cD	-	-	-	-	-	-



Table 32. Instruction Summary (Continued)

Instruction and Operation	Address Mode		Opcode Byte (Hex)	Flags Affected					
	dst	src		C	Z	S	V	D	H
if cc is true, PC←dst			c = 0 - F 30						
JR cc, dst if cc is true, PC←PC + dst Range: +127, -128	RA		cB c = 0 - F	-	-	-	-	-	-
LD dst, src dst←src	r	Im	rC	-	-	-	-	-	-
	r	R	r8						
	R	r	r9						
			r = 0-F						
	r	X	C7						
	X	r	D7						
	r	lr	E3						
	lr	r	F3						
	R	R	E4						
	R	IR	E5						
	R	IM	E6						
	IR	IM	E7						
	IR	R	F5						
LDC dst, src dst←src	r	lrr	C2	-	-	-	-	-	-
LDCI dst, src dst←src r←r + 1; rr←rr + 1	lr	lrr	C3	-	-	-	-	-	-
NOP			FF	-	-	-	-	-	-
OR dst, src	Note ^a		4[1	-	*	*	0	-	-



Table 32. Instruction Summary (Continued)

Instruction and Operation	Address Mode		Opcode Byte (Hex)	Flags Affected					
	dst	src		C	Z	S	V	D	H
dst ← dst OR src									
POP	R		50	-	-	-	-	-	-
dst ← @SP; SP ← SP + 1	IR		51						
PUSH src	R		70	-	-	-	-	-	-
SP ← SP - 1; @SP ← src	IR		71						
RCF			CF	0	-	-	-	-	-
C ← 0									
RET			AF	-	-	-	-	-	-
PC ← @SP; SP ← SP + 2									
RL dst	R		90	*	*	*	*	-	-
	IR		91						
RLC dst	R		10	*	*	*	*	-	-
	IR		11						
RR dst	R		E0	*	*	*	*	-	-
	IR		E1						
RRC dst	R		C0	*	*	*	*	-	-
	IR		C1						
SBC dst, src	Note ^a		3[]	*	*	*	*	1	*
dst ← dst ← src ← C									
SCF			DF	1	-	-	-	-	-
C ← 1									
SRA dst	R		D0	*	*	*	0	-	-
	IR		D1						
SRP dst	Im		31	-	-	-	-	-	-



Table 32. Instruction Summary (Continued)

Instruction and Operation	Address Mode		Opcode Byte (Hex)	Flags Affected					
	dst	src		C	Z	S	V	D	H
RP←src									
STOP			6F	1	-	-	-	-	-
SUB dst, src	Note ^a		2[]	[[[[1	[
dst←dst←src									
SWAP dst	R		F0	X	*	*	X	-	-
	IR		F1						
TCM dst, src	Note ^a		6[]	-	*	*	0	-	-
(NOT dst)									
AND src									
TM dst, src	Note ^a		7[]	-	*	*	0	-	-
dst AND src									
XOR dst, src	Note ^a		B[]	-	*	*	0	-	-
dst←dst									
XOR src									

- a. These instructions have an identical set of addressing modes, which are encoded for brevity. The first Op Code nibble is found in the instruction set table above. The second nibble is expressed symbolically by a '[']' in this table, and its value is found in the following table to the left of the applicable addressing mode pair.

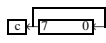
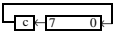
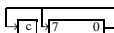
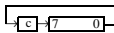
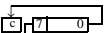
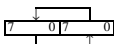
For example, the opcode of an ADC instruction using the addressing modes r (destination) and Ir (source) is 13.

Address Mode		Lower Opcode Nibble
dst	src	
r	r	[2]
r	Ir	[3]
R	R	[4]
R	IR	[5]
R	IM	[6]
IR	IM	[7]

OPCODE MAP

Upper Nibble (Hex)	Lower Nibble (Hex)															
	0	1	2	3	4	5	6	7	8	9	A	B	C	D	E	F
0	6.6 DEC R1	6.5 DEC IR1	6.5 ADD r1, r2	8.5 ADD r1, Ir2	10.5 ADD R2, R1	10.5 ADD IR2, R1	10.5 ADD R1, 1M	10.5 ADD R1, 1M	6.5 LD r1, R2	6.5 LD r2, R1	12/10.5 DJNZ r1, RA	12/0.0 JACC, RA	6.5 LD r1, 1M	12/10.0 JP cc, DA	6.5 INC r1	
1	6.5 RLC R1	6.5 RLC IR1	6.5 ADC r1, r2	6.5 ADC r1, Ir2	10.5 ADC R2, R1	10.5 ADC IR2, R1	10.5 ADC R1, 1M	10.5 ADC R1, 1M								
2	6.5 INC R1	6.6 WC IR1	6.5 SUB r1, r2	6.5 SUB r1, Ir2	10.5 SUB R2, R1	10.5 SUB IR2, R1	10.5 SUB R1, 1M	10.5 SUB R1, 1M								
3	6.5 JP IRR1	6.1 SRP 1M	6.5 SBC r1, r2	6.5 SBC r1, Ir2	10.5 SBC R2, R1	10.5 SBC IR2, R1	10.5 SBC R1, 1M	10.5 SBC R1, 1M								
4	8.5 DA R1	8.5 DA IR1	6.5 OR r1, r2	6.5 OR r1, Ir2	10.5 OR R2, R1	10.5 OR IR2, R1	10.5 OR R1, 1M									
5	10.5 POP R1	10.5 POP IR1	6.5 AND r1, r2	6.5 AND r1, Ir2	10.5 AND R2, R1	10.5 AND IR2, R1	10.5 AND R1, 1M	10.5 AND R1, 1M								
6	6.5 COM R1	6.5 COM IR1	6.5 TCM r1, r2	6.5 TCM r1, Ir2	10.5 TCM R2, R1	10.5 TCM IR2, R1	10.5 TCM R1, 1M	10.5 TCM R1, 1M								6.0 STOP
7	10/12.1 PUSH R2	10/12.1 PUSH IR2	6.5 TM r1, r2	6.5 TM r1, Ir2	10.5 TM R2, R1	10.5 TM IR2, R1	10.5 TM R1, 1M	10.5 TM R1, 1M								7.0 HALT
8	10.5 DECW RR1	10.5 DECW IR1	12.0 LDE r1, Ir2	18.0 LDEI r1, Ir2												6.1 DI
9	6.5 RL R1	6.5 RL IR1	12.0 LDE r1, Ir2	18.0 LDEI r1, Ir2												6.1 EI
A	10.5 INCW RR1	10.5 INCW IR1	6.5 CP r1, r2	6.5 CP r1, Ir2	10.5 CP R2, R1	10.5 CP IR2, R1	10.5 CP R1, 1M	10.5 CP R1, 1M								14.0 RET
B	6.5 CLR R1	6.5 CLR IR1	6.5 XOR r1, r2	6.5 XOR r1, Ir2	10.5 XOR R2, R1	10.5 XOR IR2, R1	10.5 XOR R1, 1M	10.5 XOR R1, 1M								16.0 IRET
C	6.5 RRC R1	6.5 RRC IR1	12.0 LDC r1, Ir2	18.0 LDC r1, Ir2				10.5 LD r1, x, R2								6.5 RCF
D	6.5 SRA R1	6.5 SRA IR1	12.0 LDC r1, Ir2	18.0 LDCI r1, Ir2	20.0 CALL* IRR1		20.0 CALL DA	10.5 LD r2, x, R								6.5 SCF
E	6.5 RR R1	6.5 RR IR1		6.5 LD r1, IR2	10.5 LD R2, R1	10.5 LD IR2, R1	10.5 LD R1, 1M	10.5 LD R1, 1M								6.5 CCF
F	8.5 SWAP R1	8.5 SWAP IR1		6.5 LD r1, r2		10.5 LD R2, IR1										6.0 NOP

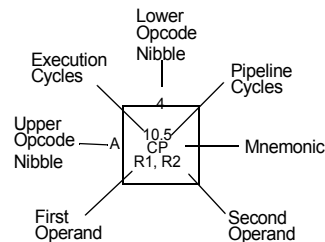

Legend:

R = 8-bit Address
r = 4-bit Address
R1 or r1 = Dst Address
R2 or r2 = Src Address

Sequence:

Opcode, First Operand,
Second Operand

Note: Blank areas not defined

*2-byte instruction appears as
a 3-byte instruction

Figure 47. Opcode Map

PACKAGE INFORMATION

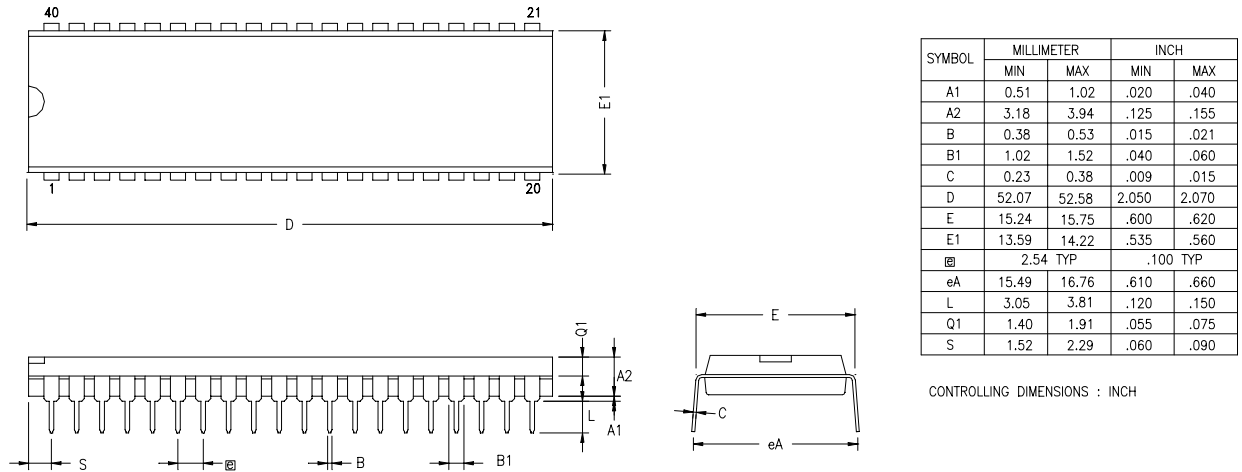
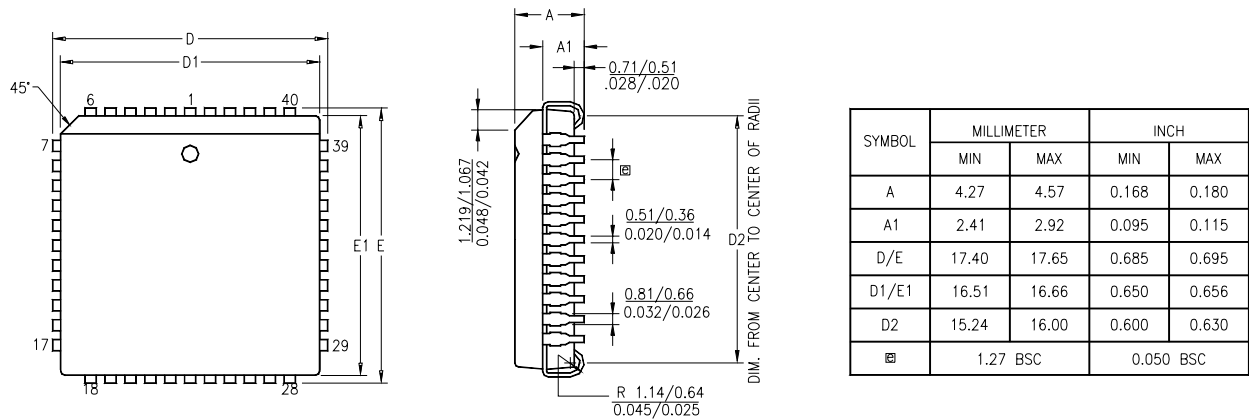

Figure 48. 40-Pin DIP Package Diagram



- NOTES:
1. CONTROLLING DIMENSION : INCH
 2. LEADS ARE COPLANAR WITHIN 0.004".
 3. DIMENSION : $\frac{MM}{INCH}$

Figure 49. 44-Pin PLCC Package Diagram

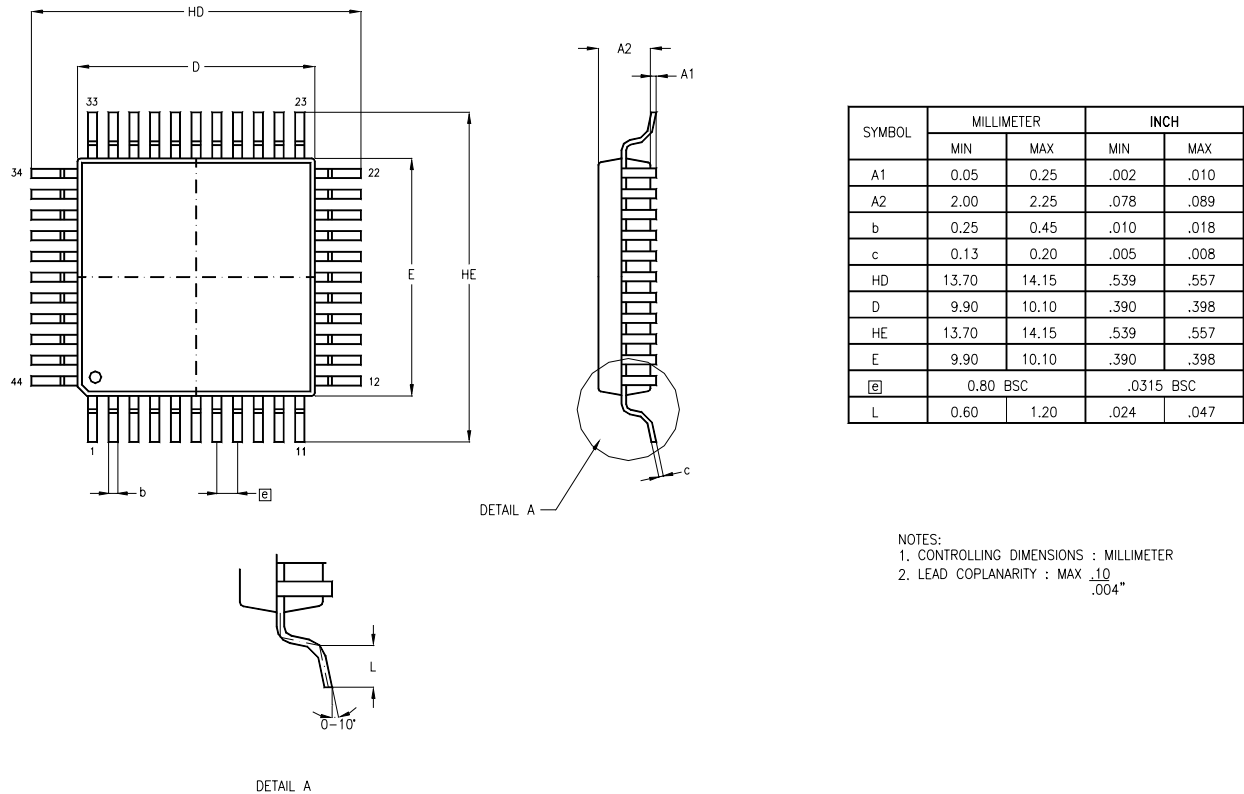

Figure 50. 44-Pin LQFP Package Diagram

ORDERING INFORMATION

Z86E61			
16 MHz		20 MHz	
40-Pin DIP	44-Pin PLCC	40-Pin DIP	44-Pin PLCC
Z86E6116PSC	Z86E6116VSC	Z86E6120PSC	Z86E6120VSC
Z86E63			
16 MHz		20 MHz	
40-Pin DIP	44-Pin PLCC	40-Pin DIP	44-Pin PLCC
Z86E6316PSC	Z86E6316VSC	Z86E6320PSC	Z86E6320VSC

For fast results, contact your local Zilog sales office for assistance in ordering the part desired.



CODES

- Preferred Package
P = Plastic DIP
V = Plastic Chip Carrier
- Temperature
S = 0°C to +70°C
- Speeds
12 = 16 MHz
16 = 20 MHz
- Environmental
C = Plastic Standard

Example:

