

THIS DRAWING IS UNPUBLISHED. RELEASED FOR PUBLICATION
 © COPYRIGHT - By - ALL RIGHTS RESERVED.

LOC	DIST	REVISIONS			
P	LTR	DESCRIPTION	DATE	DWN	APVD
AF	50	B1	ECO-14-002653	24FEB14	PKS RRP

IDENTIFICATION NUMBER 15T
 FOR MAGNET WIRE RANGE

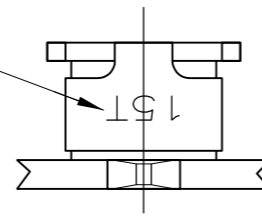

- 1 CONTINUOUS STRIP ON REELS WITH TERMINALS LOCATED ON 5.59±0.08 [.220±.003] CENTERS.
- 2 SLOT ACCEPTS A 7 STRAND TINSEL WIRE. 0.79±0.08 [.031±.003] DIA.
- 3 AFTER INSERTION INTO PLASTIC HOLDER TAB PORTION MUST BE BENT OVER 45° TO 90°, OR POTTED TO PERVENT PULL-OUT WHEN MATING RECEPTACLE IS DISCONNECTED.

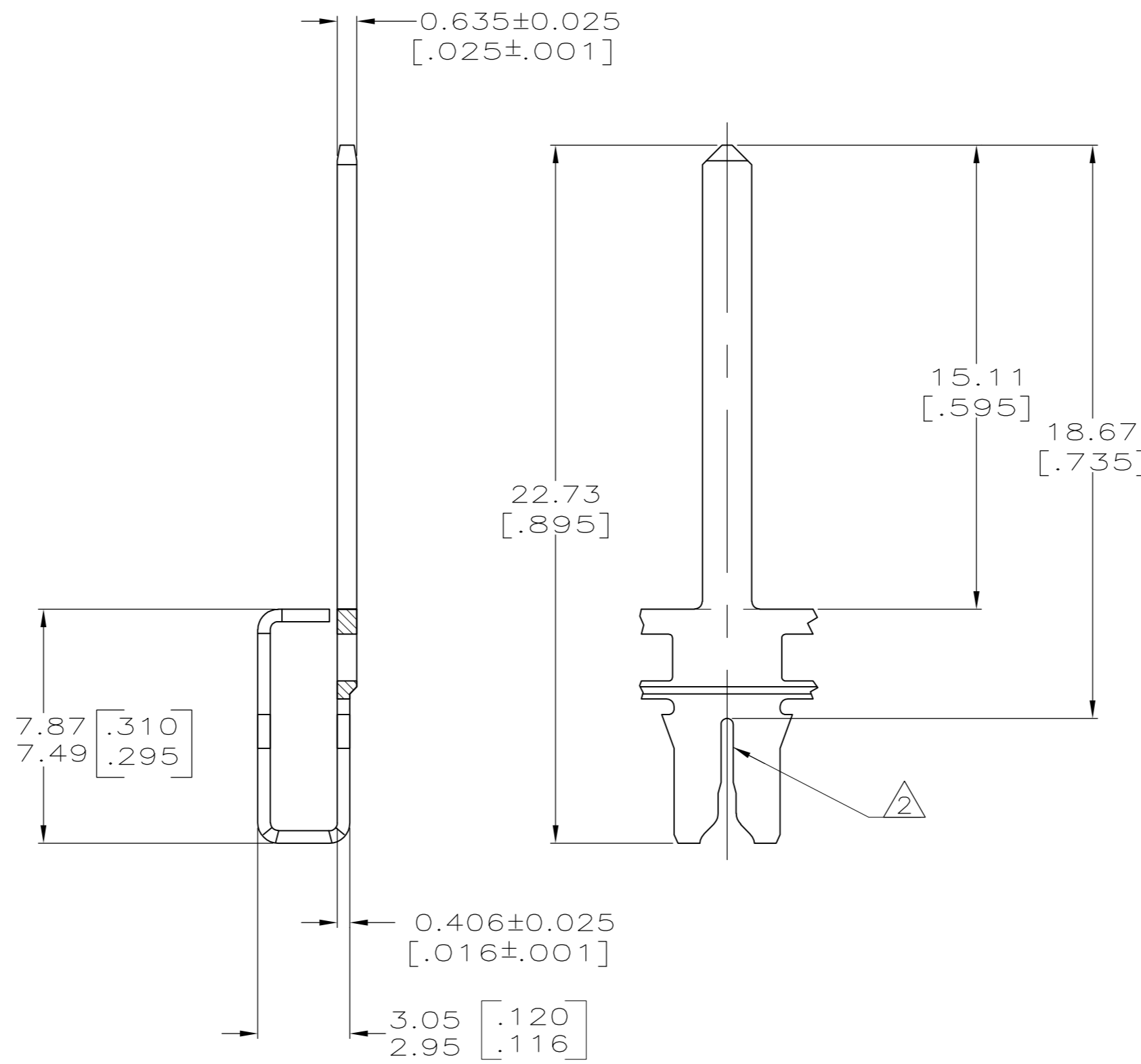
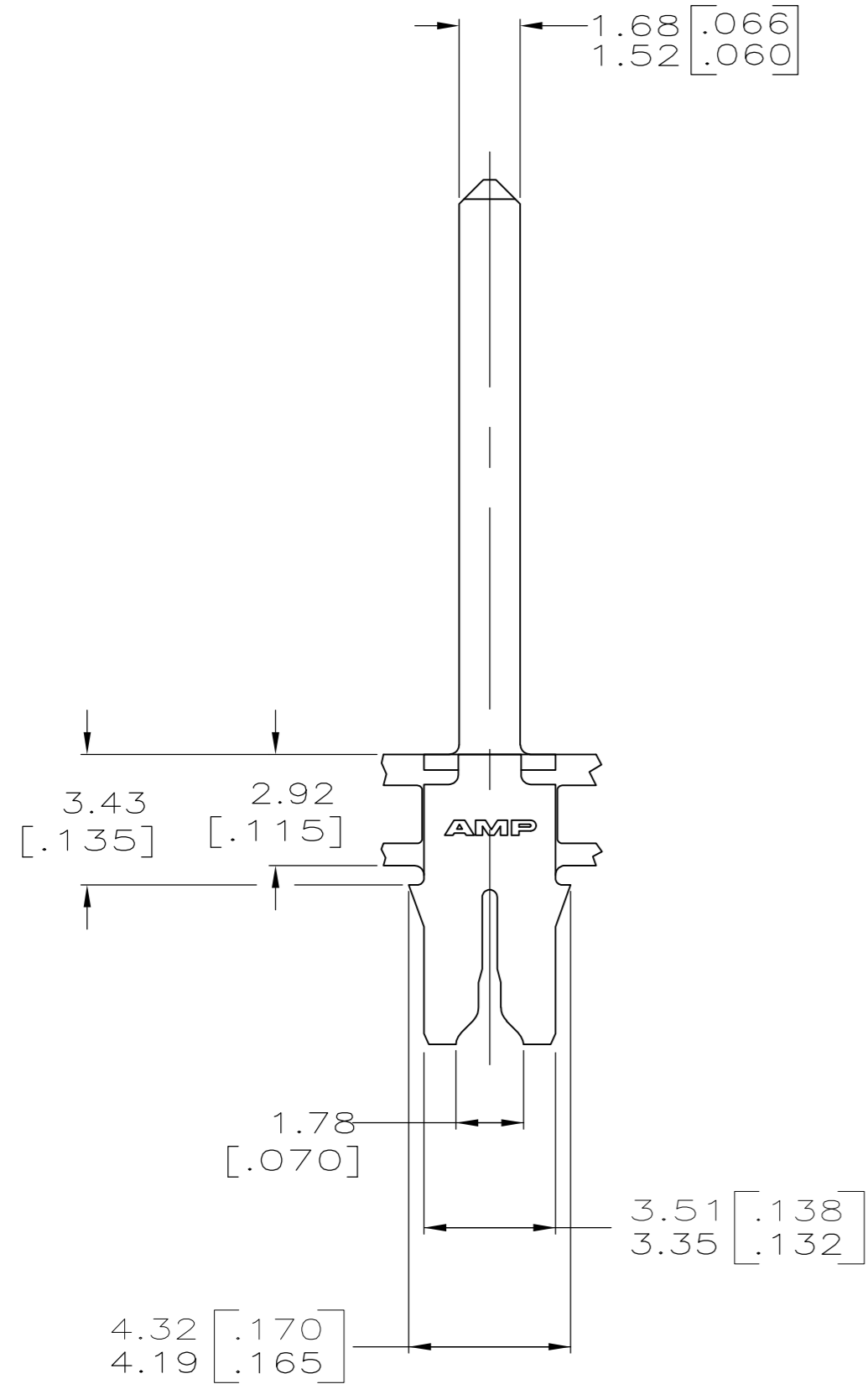

1217595-1
 PART NUMBER

THIS DRAWING IS A CONTROLLED DOCUMENT.		DWN	JR RUTH	23FEB01		TE Connectivity									
DIMENSIONS: INCHES		CHK	MS FEHER	23FEB01		NAME									
TOLERANCES UNLESS OTHERWISE SPECIFIED:		APVD	K RANDOLPH	23FEB01		PRODUCT SPEC									
0 PLC ± - 1 PLC ± - 2 PLC ± 0.25[.010] 3 PLC ± - 4 PLC ± - ANGLES ± -		APPLICATION SPEC		108-2012		TAB, 1.60[.063] SERIES, MAG-MATE™									
MATERIAL	BRASS	FINISH	TIN PLATED	WEIGHT	-	SIZE	A2	CAGE CODE	00779	DRAWING NO	C=1217595	RESTRICTED TO	-		
CUSTOMER DRAWING										SCALE	6:1	SHEET	1 of 1	REV	B1