

CUSTOMER PRINT

PART NUMBER: W4Z85-XSG-P-300

NOTES:

1. ALL PARTS TO BE BULK PACKED UNLESS NOTED.
2. INSTA CLICK PANEL MOUNT ASSEMBLY IS SUPPLIED WITH CONTACTS INSERTED INTO THE CONNECTOR WITH HEX SCREWS ALL READY TO SCREW WIRE ON FIELD. ACCEPTS WIRE 12, 14 AND 16 AWG.
3. ALL DIMENSIONS ARE REFERENCED IN INCHES [MM], WITHIN ± 0.015 UNLESS NOTED.

ASSEMBLY PART NUMBERS	CONTACT #SIZE
W4Z85-3SG-P-300	3 # 14
W4Z85-4SG-P-300	4 # 14

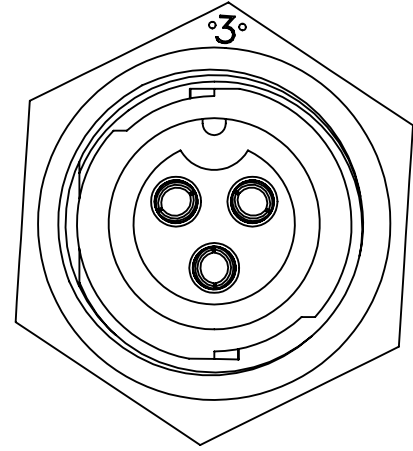

MATING FACE  
W4Z85-3SG-P-300

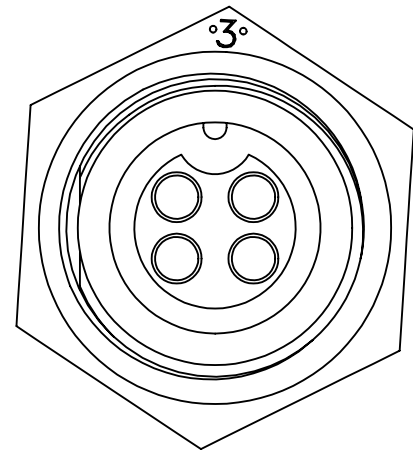

MATING FACE  
W4Z85-4SG-P-300

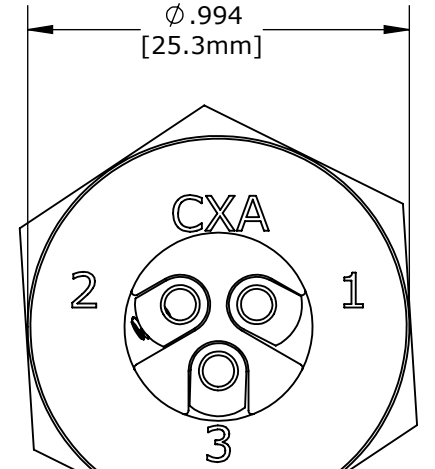
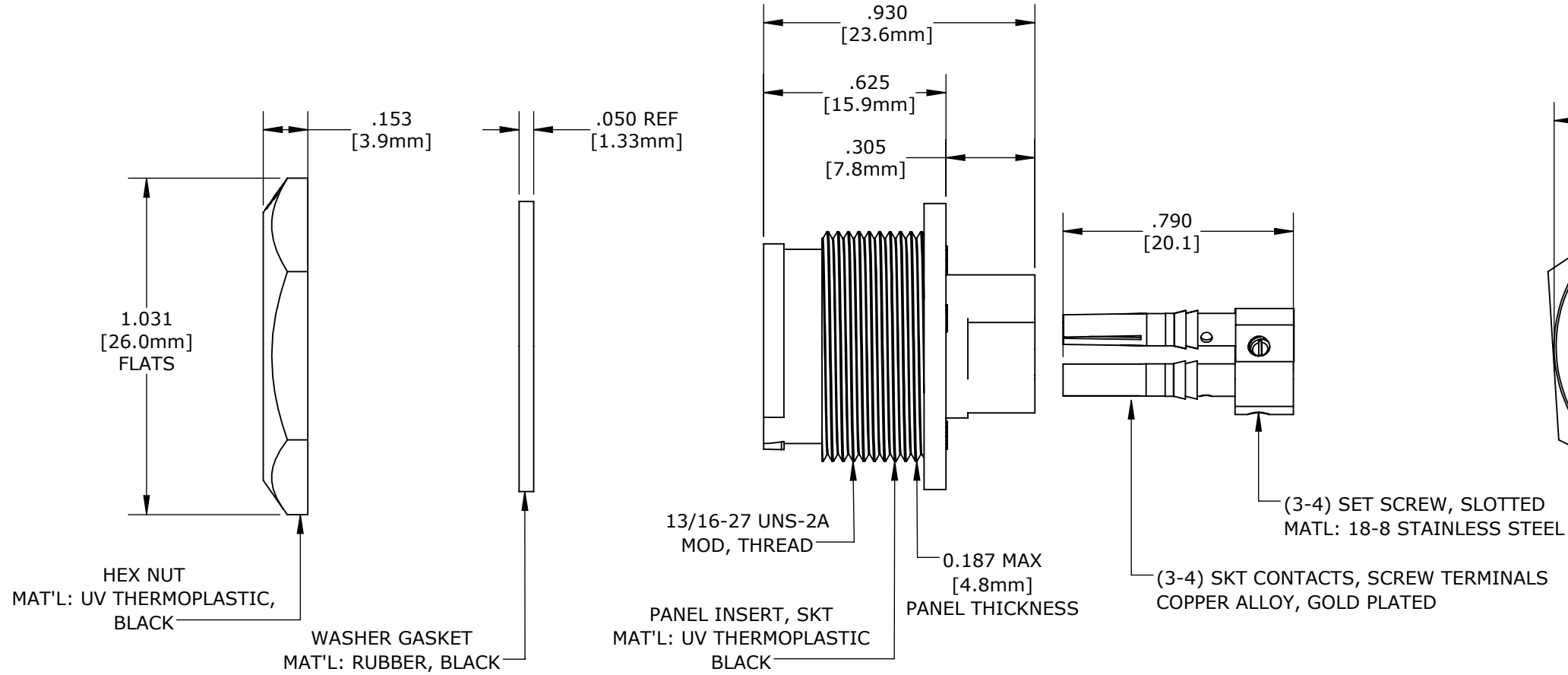

WIRING END  
W4Z85-3SG-P-300

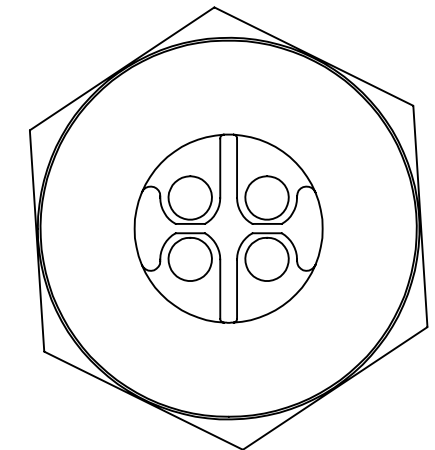

WIRING END  
W4Z85-4SG-P-300

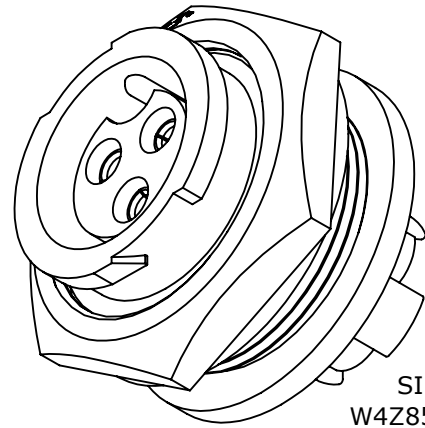

SIDE VIEW  
W4Z85-3SG-P-300

**CUSTOMER APPROVAL**

THIS DOCUMENT CONTAINS CONFIDENTIAL INFORMATION PROPRIETARY TO CONXALL CORPORATION. ANY REPRODUCTION, DISCLOSURE, OR USE OF THIS DOCUMENT /INFORMATION IS EXPRESSLY PROHIBITED UNLESS AUTHORIZED IN WRITING BY CONXALL CORPORATION.

APPROVED BY: \_\_\_\_\_  
 DATE: \_\_\_\_\_

(RoHS COMPLIANT)

0A	AM	02/24/22	FIRST DRAWN
REV.	INIT.	DATE	DESCRIPTION
AM		02/24/22	
<small>ALL INFORMATION ILLUSTRATED IS THE PROPERTY OF CONXALL CORPORATION. UNAUTHORIZED DUPLICATION OR DISTRIBUTION OF THIS DOCUMENT IS PROHIBITED.</small>			<p>601 E. WILDWOOD VILLA PARK, IL 60181</p>
<small>ALL UNITS ARE IN FEET, INCHES, FRACTION OF INCHES AND DECIMALS. UNLESS OTHERWISE SPECIFIED TOLERANCES: 3 PLACE DECIMALS ±.005 ANGLES ±1° FRACTIONS ±1/16 - CRITICAL CHARACTERISTIC FLAG PER SPEC. XXXX</small>			
APPROVED BY:		TITLE: PANEL MOUNT ASSEMBLY (3-4) #14 SOCKET CONTACT	
SCALE: NTS		SIZE: B	SHEET: 1 OF 1
FILE: _____		DIRECTORY: SLW	PART NUMBER: W4Z85-XSG-P-300
CUSTOMER: STANDARD PRODUCT			REV: 0A