



0.4 Ω, Low Resistance and Capacitance, Dual DPDT / Quad SPDT Analog Switch

DESCRIPTION

The DG2523 and DG2524 are four-channel single-pole double-throw (SPDT) analog switches. The DG2523 has two control inputs that each controls a pair of single-pole double-throw (SPDT). It is also known as a two-channel double-pole double-throw (DPDT) configuration. The DG2524 has an EN pin to enable the device when the logic is low.

The parts are designed to operate from 1.8 V to 5.5 V single power rail. All switches conduct equally well in both directions, offering rail to rail signal switching and can be used both as multiplexers as well as de-multiplexers. The parts feature low control logic threshold. Break-before-make switching is guaranteed.

The DG2523 and DG2524 exhibit low parasitic capacitance, low leakage, and highly matched low and flat switch resistance over the full signal range characters that are important for precision analog designs.

The high bandwidth and excellent total harmonic distortion (THD) performance make them ideal for both analog and digital signal switching in space constrain applications requiring high performance and efficient use of board space.

The DG2523 and DG2524 come in Pb-free QFN-16 package of 3 mm x 3 mm.

BENEFITS

- Low and flat resistance
- Excellent total harmonic distortion
- Low parasitic capacitance
- Low voltage control interface

FEATURES

- 1.8 V to 5.5 V single supply operation
- Low resistance: 0.4 Ω / typ. at 2.7 V
- Highly flat and matched R_{on}
- Low parasitic capacitance, C_{on} = 26 pF, C_{off} = 14.5 pF
- Typical switch off leakage of 40 pA
- High bandwidth: 310 MHz
- Guaranteed logic high 1.2 V, logic low 0.3 V
- Break before make switching
- Signal swing over V+ capable
- Power down protection
- Latch up current: 300 mA (JESD78)
- ESD/HBM: > 6 kV
- Material categorization: for definitions of compliance please see www.vishay.com/doc?99912



RoHS COMPLIANT

APPLICATIONS

- Automatic test equipment
- Data acquisition systems
- Meters and instruments
- Medical and healthcare systems
- Communication systems
- Audio and video signal routing
- Battery powered systems
- Computer peripherals
- Data storage
- Relay replacement

FUNCTIONAL BLOCK DIAGRAM AND PIN CONFIGURATION

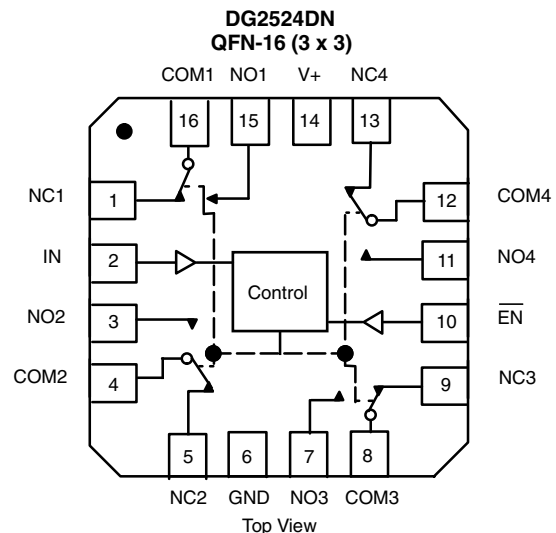
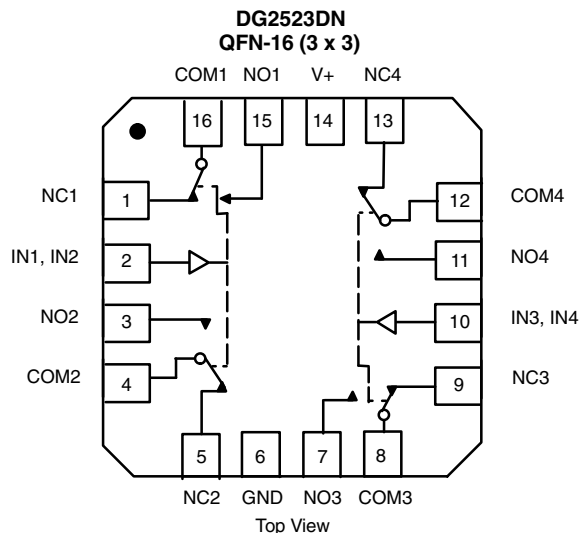



TRUTH TABLE DG2523		
INx	NC1, 2, 3, and 4	NO1, 2, 3, and 4
0	On	Off
1	Off	On

TRUTH TABLE DG2524			
EN	LOGIC IN	NC1, 2, 3, and 4	NO1, 2, 3, and 4
1	x	Off	Off
0	0	On	Off
0	1	Off	On

ORDERING INFORMATION			
TEMPERATURE RANGE	PACKAGE	PART NUMBER	MIN. ORDER / PACK. QUANTITY
-40 °C to +85 °C lead (Pb)-free	QFN-16 (3 mm x 3 mm)	DG2523DN-T1-GE4	Tape and reel, 2500 units
		DG2524DN-T1-GE4	

ABSOLUTE MAXIMUM RATINGS (T _A = 25 °C, unless otherwise noted)				
PARAMETER		SYMBOL	LIMIT	UNIT
Reference to GND	V+		-0.3 to +6	V
	IN, COM, NC, NO ^a		-0.3 to (V+ + 0.3)	
Current (any terminal except NO, NC, or COM)			30	mA
Continuous current (NO, NC, or COM)			± 300	
Peak current (pulsed at 1 ms, 10 % duty cycle)			± 500	
Storage temperature (D suffix)			-65 to +150	°C
Package solder reflow conditions ^d	QFN-16		250	
Power dissipation (packages) ^b	QFN-16 ^c		1385	

Notes

- a. Signals on NC, NO, or COM, or IN exceeding V+ will be clamped by internal diodes. Limit forward diode current to maximum current ratings.
- b. All leads welded or soldered to PC board.
- c. Derate 17.3 mW/°C above 70 °C.
- d. Manual soldering with iron is not recommended for leadless components. The miniQFN-16 is a leadless package. The end of the lead terminal is exposed copper (not plated) as a result of the singulation process in manufacturing. A solder fillet at the exposed copper lip cannot be guaranteed and is not required to ensure adequate bottom side solder interconnection.

Stresses beyond those listed under "Absolute Maximum Ratings" may cause permanent damage to the device. These are stress ratings only, and functional operation of the device at these or any other conditions beyond those indicated in the operational sections of the specifications is not implied. Exposure to absolute maximum rating conditions for extended periods may affect device reliability.



SPECIFICATIONS (V+ = 3 V)										
PARAMETER	SYMBOL	TEST CONDITIONS unless otherwise specified V+ = 3 V, ± 10 %, VIN = 0.5 V or 1.4 V ^e	TEMP. ^a	LIMITS -40 °C to +85 °C			UNIT			
				MIN. ^b	TYP. ^c	MAX. ^b				
Analog Switch										
Analog signal range ^d	V _{NO} , V _{NC} , V _{COM}		Full	0	-	V+	V			
On-resistance	R _{ON}	V+ = 2.7 V, V _{COM} = 0 to 2.7 V, I _{NO} , I _{NC} = 100 mA	Room	-	0.40	0.55	Ω			
			Full	-	-	0.65				
R _{ON} flatness ^d	R _{ON} flatness	V+ = 2.7 V, V _{COM} = 0 to V+, I _{NO} , I _{NC} = 100 mA	Full	-	0.03	0.08	Ω			
R _{ON} match ^d	ΔR _{ON}		Room	-	0.05	-				
Switch off leakage current	I _{NO(off)} , I _{NC(off)}	V+ = 5.5 V, V _{NO} , V _{NC} = 0.5 V / 4 V, V _{COM} = 4 V / 0.5 V	Room	-1	0.04	1	nA			
			Full	-5	-	5				
	Room		-1	0.17	1					
	Full		-5	-	5					
Channel-on leakage current	I _{COM(on)}	V+ = 5.5 V, V _{NO} , V _{NC} = V _{COM} = 0.5 V / 4 V	Room	-1	0.17	1	nA			
			Full	-5	-	5				
Digital Control										
Input high voltage	V _{INH}		Full	1.2	-	-	V			
Input low voltage	V _{INL}			-	-	0.3				
Input capacitance	C _{IN}		Full	-	5	-	pF			
Input current	I _{INL} or I _{INH}	V _{IN} = 0 or V+	Full	-1	-	1	μA			
Dynamic Characteristics										
Turn-on time	t _{ON}	V _{NO} or V _{NC} = 1.5 V, R _L = 50 Ω, C _L = 35 pF	Room	-	38	60	μs			
			Full	-	-	70				
Turn-off time	t _{OFF}		Room	-	0.43	1				
			Full	-	-	3				
Break-before-make time	t _d			Full	1	-		-		
Charge injection ^d	Q _{INJ}		C _L = 1 nF, V _{GEN} = 1.5 V, R _{GEN} = 0 Ω	Room	-	-19		-	pC	
-3 dB bandwidth	BW	R _L = 50 Ω, C _L = 5 pF	Room	-	310	-	MHz			
Off-isolation ^d	OIRR	R _L = 50 Ω, C _L = 5 pF, f = 100 kHz	Room	-	-82	-	dB			
		R _L = 50 Ω, C _L = 5 pF, f = 1 MHz		-	-55	-				
Crosstalk ^{d, f}	X _{TALK}	R _L = 50 Ω, C _L = 5 pF, f = 100 kHz		-	-89	-				
		R _L = 50 Ω, C _L = 5 pF, f = 1 MHz		-	-61	-				
Total harmonic distortion plus noise	THD + N	2.5 V, signal peak to peak voltage R _L = 32 Ω, f = 1 kHz			-	-100		-		
NO, NC off capacitance ^d	C _{NO(off)}	f = 1 MHz		Room	-	14.5		-	pF	
	C _{NC(off)}		-		14.5	-				
Channel-on capacitance ^d	C _{NO(on)}		-		26	-				
	C _{NC(on)}		-		26	-				
Power Supply										
Power supply range	V+					1.8	-	5.5		V
Power supply current	I+	V _{IN} = 0 or V+	Full	-	29	60	μA			

Notes

- a. Room = 25 °C, full = as determined by the operating suffix.
- b. The algebraic convention whereby the most negative value is a minimum and the most positive a maximum, is used in this data sheet.
- c. Typical values are for design aid only, not guaranteed nor subject to production testing.
- d. Guarantee by design, not subjected to production test.
- e. V_{IN} = input voltage to perform proper function.
- f. Crosstalk measured between channels.



TYPICAL CHARACTERISTICS (T_A = 25 °C, unless otherwise noted)

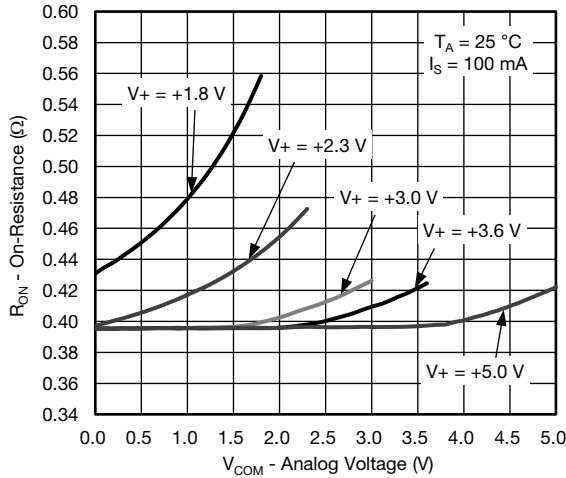

RON vs. VCOM and Supply Voltage

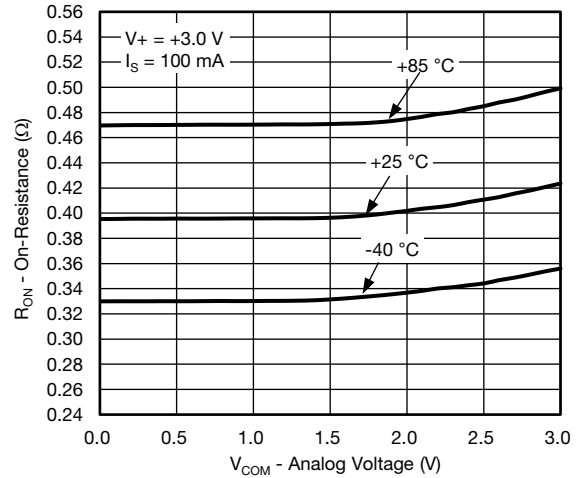

RON vs. Analog Voltage and Temperature

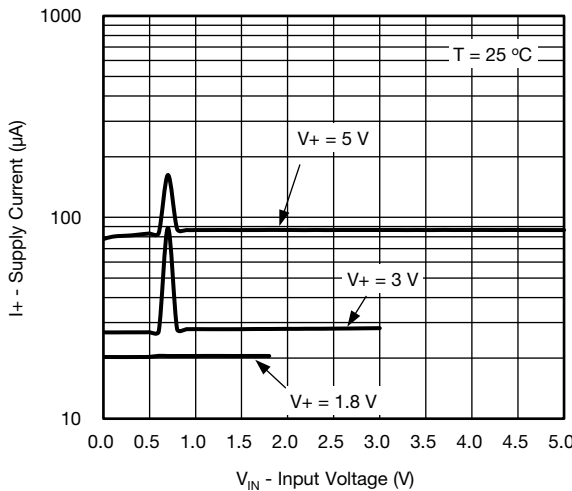

Supply Current vs. Input Voltage

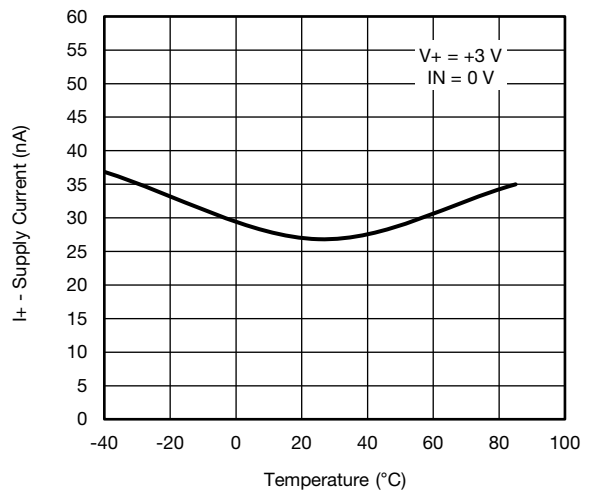

Supply Current vs. Temperature

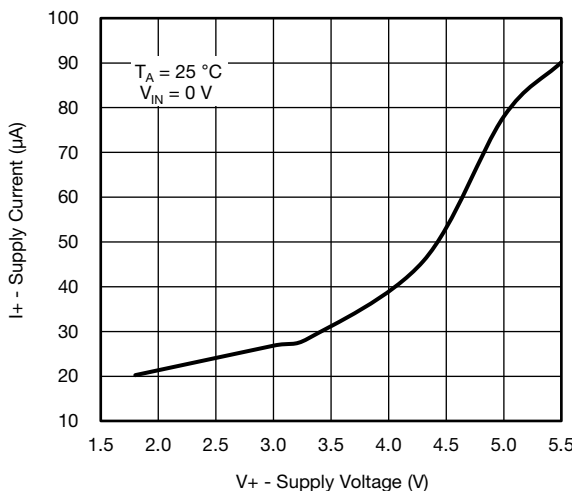

Supply Current vs. Supply Voltage

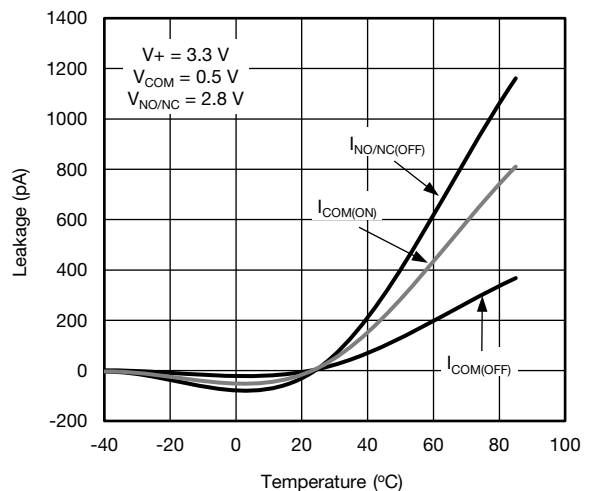

Leakage Current vs. Temperature



TYPICAL CHARACTERISTICS (T_A = 25 °C, unless otherwise noted)

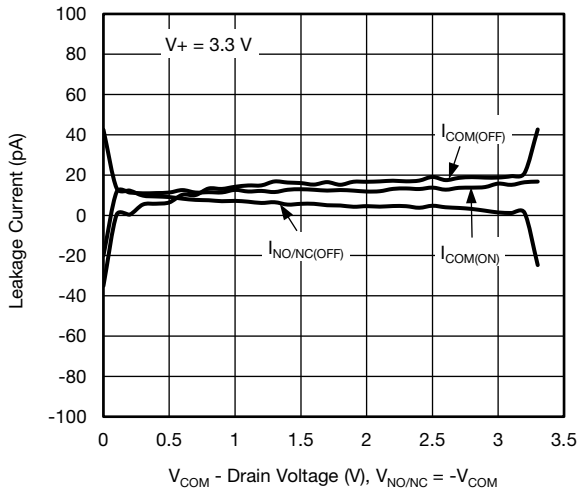

Leakage Current vs. Drain Voltage

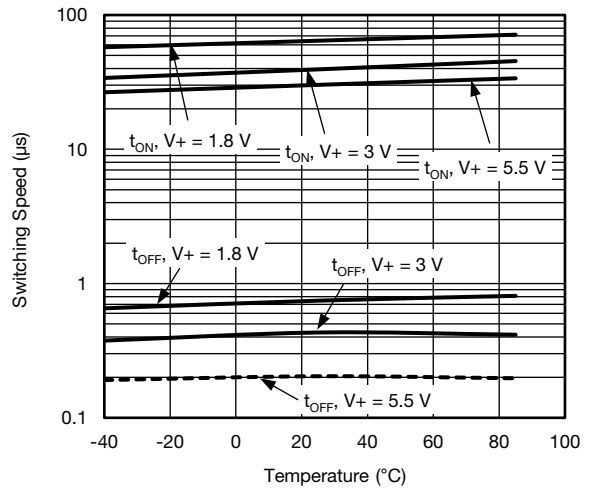

Switching Time vs. Temperature

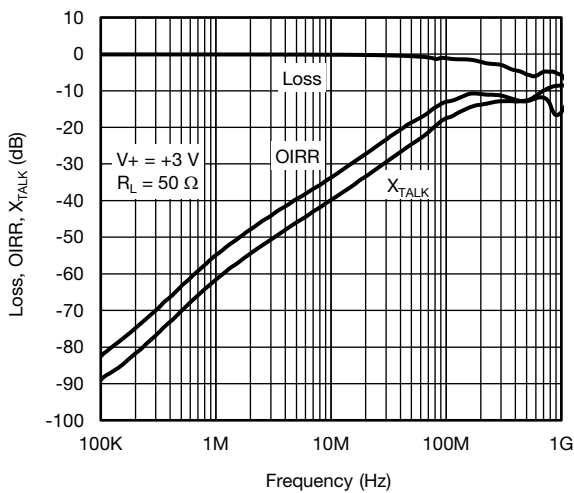

Insertion Loss, Off-Isolation Crosstalk vs. Frequency

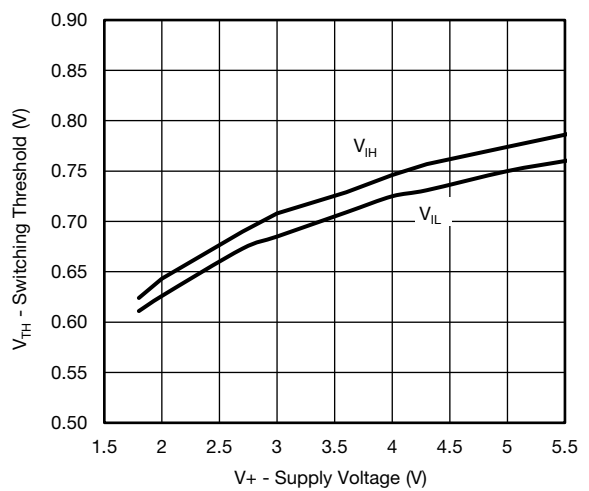

Switching Threshold vs. Supply Voltage



TYPICAL CHARACTERISTICS ($T_A = 25\text{ }^\circ\text{C}$, unless otherwise noted)

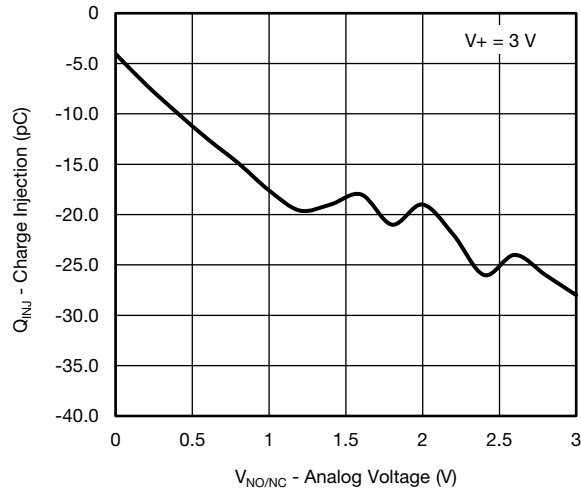

Charge Injection vs. Analog Voltage

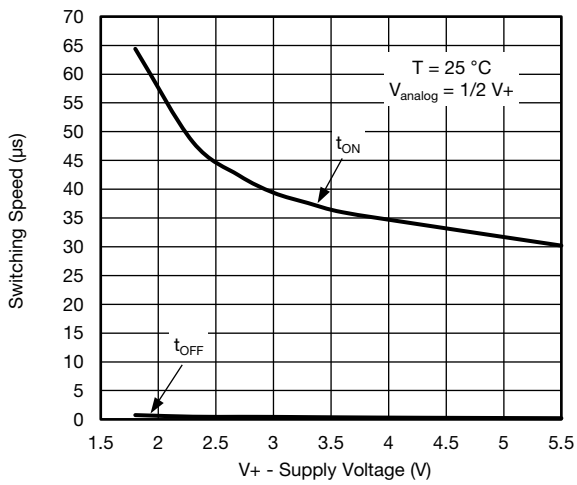

Switching Time vs. Supply Voltage

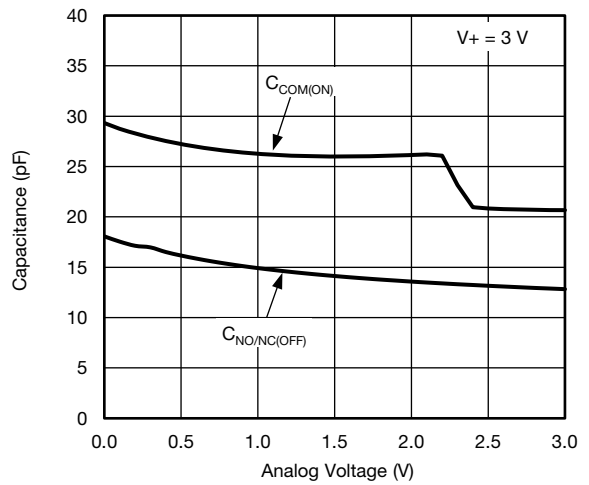

Capacitance vs. Analog Voltage

TEST CIRCUITS

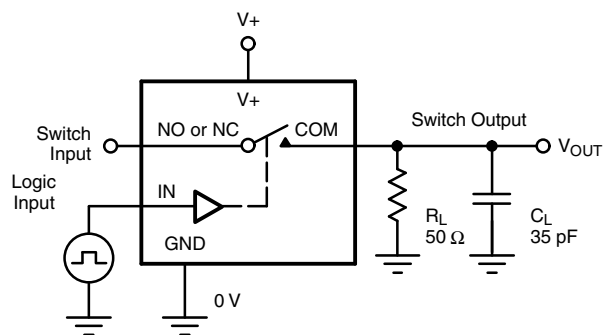

C_L (includes fixture and stray capacitance)

$$V_{OUT} = V_{COM} \left(\frac{R_L}{R_L + R_{ON}} \right)$$

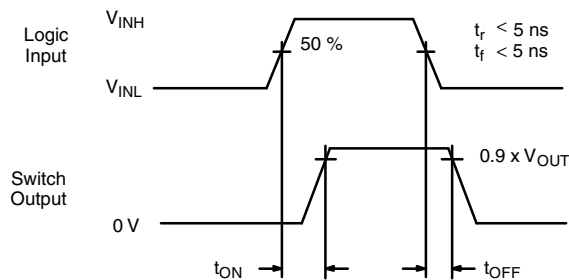

Logic "1" = Switch On
Logic input waveforms inverted for switches that have the opposite logic sense.

Fig. 1 - Switching Time

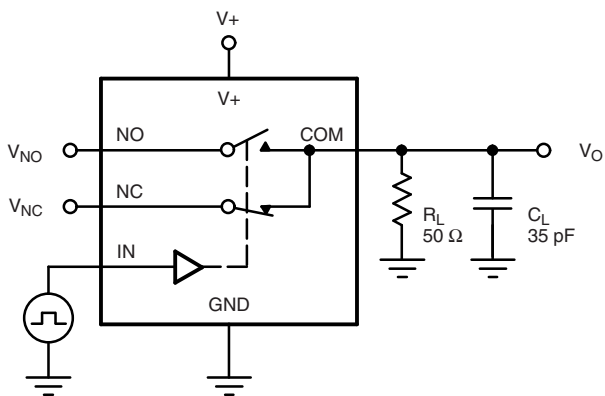

C_L (includes fixture and stray capacitance)

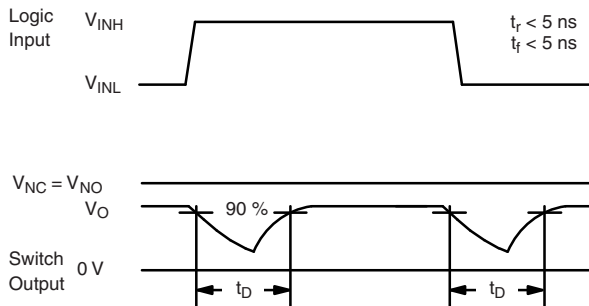
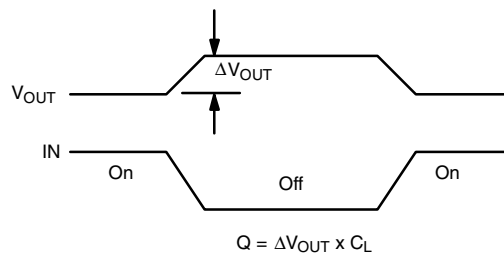
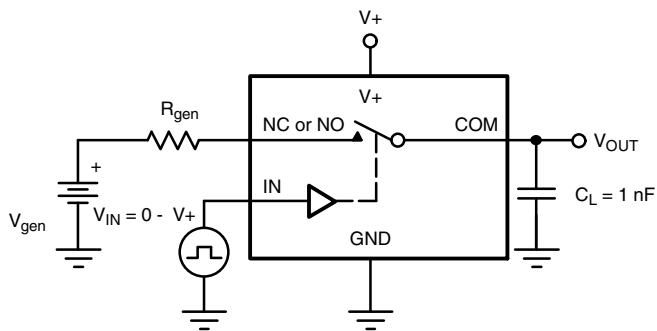
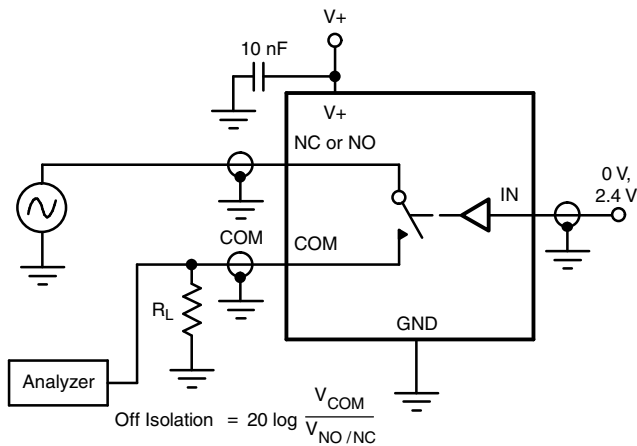
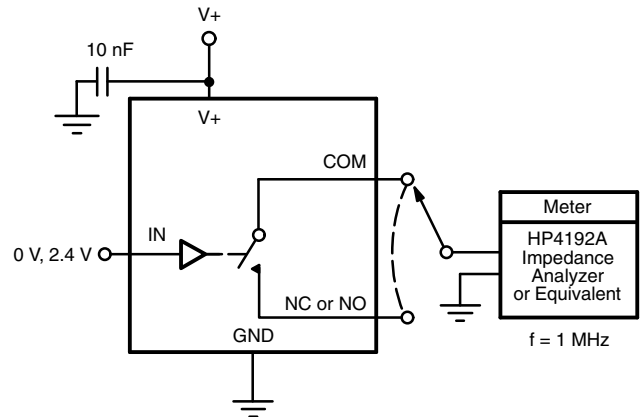

Fig. 2 - Break-Before-Make Interval



IN depends on switch configuration: input polarity determined by sense of switch.

Fig. 3 - Charge Injection

Fig. 4 - Off-Isolation

Fig. 5 - Channel Off / On Capacitance

Vishay Siliconix maintains worldwide manufacturing capability. Products may be manufactured at one of several qualified locations. Reliability data for Silicon Technology and Package Reliability represent a composite of all qualified locations. For related documents such as package/tape drawings, part marking, and reliability data, see www.vishay.com/ppg?67894.

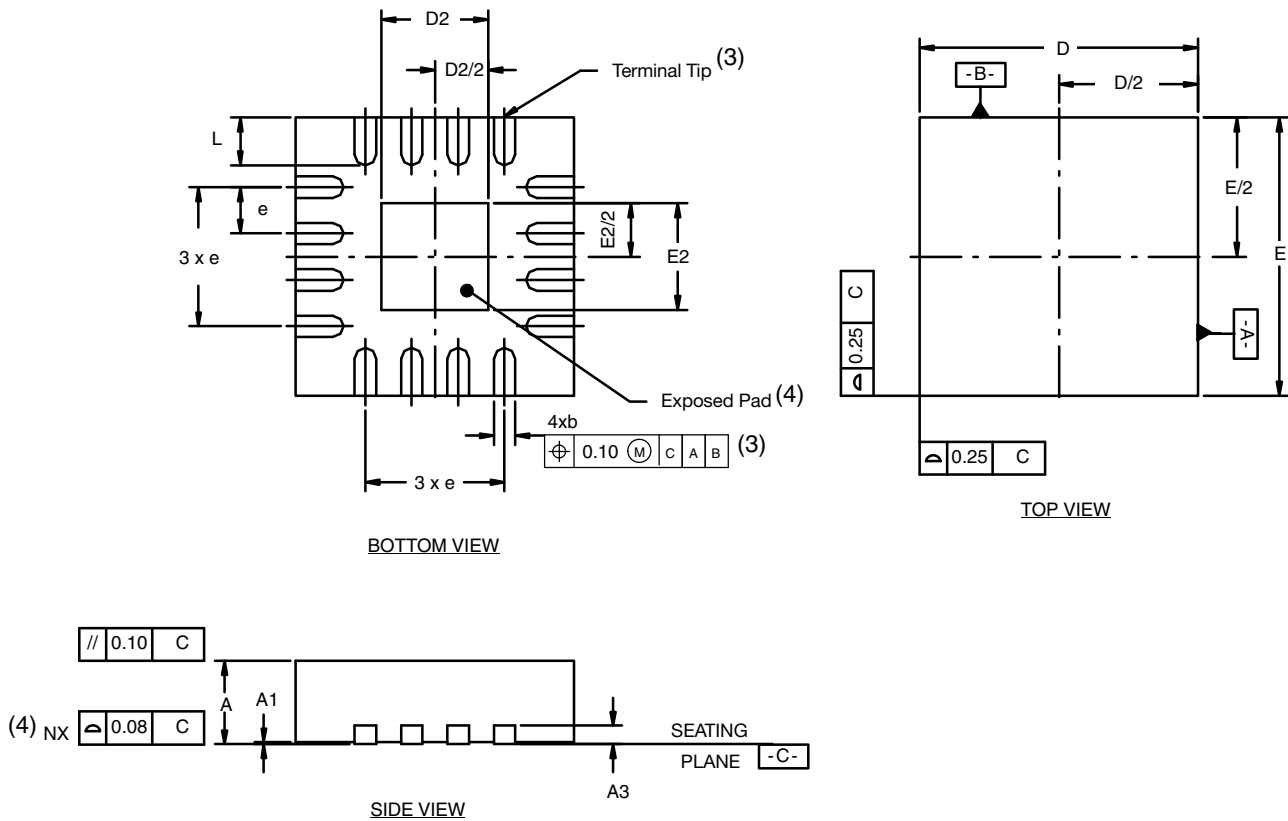
QFN-16 Lead (3 x 3)



Notes

- (1) All dimensions are in millimeters.
- (2) N is the total number of terminals.
- (3) Dimension b applies to metallized terminal and is measured between 0.25 and 0.30 mm from terminal tip.
- (4) Coplanarity applies to the exposed heat sink slug as well as the terminal.
- (5) The pin #1 identifier may be either a mold or marked feature, it must be located within the zone indicated.

DIM.	VARIATION 1						VARIATION 2					
	MILLIMETERS			INCHES			MILLIMETERS			INCHES		
	MIN.	NOM	MAX.	MIN.	NOM	MAX.	MIN.	NOM	MAX.	MIN.	NOM	MAX.
A	0.80	0.90	1.00	0.031	0.035	0.039	0.80	0.90	1.00	0.031	0.035	0.039
b	0.18	0.23	0.30	0.007	0.009	0.012	0.18	0.25	0.30	0.007	0.010	0.012
D	2.90	3.00	3.10	0.114	0.118	0.122	2.90	3.00	3.10	0.114	0.118	0.122
D_2	1.00	1.15	1.25	0.039	0.045	0.049	1.50	1.70	1.80	0.059	0.067	0.071
E	2.90	3.00	3.10	0.114	0.118	0.122	2.90	3.00	3.10	0.114	0.118	0.122
E_2	1.00	1.15	1.25	0.039	0.045	0.049	1.50	1.70	1.80	0.059	0.067	0.071
e	0.50 BSC			0.020 BSC			0.50 BSC			0.020 BSC		
L	0.30	0.40	0.50	0.012	0.016	0.020	0.30	0.40	0.50	0.012	0.016	0.020

ECN: T16-0233-Rev. D, 09-May-16
DWG: 5899



Disclaimer

ALL PRODUCT, PRODUCT SPECIFICATIONS AND DATA ARE SUBJECT TO CHANGE WITHOUT NOTICE TO IMPROVE RELIABILITY, FUNCTION OR DESIGN OR OTHERWISE.

Vishay Intertechnology, Inc., its affiliates, agents, and employees, and all persons acting on its or their behalf (collectively, "Vishay"), disclaim any and all liability for any errors, inaccuracies or incompleteness contained in any datasheet or in any other disclosure relating to any product.

Vishay makes no warranty, representation or guarantee regarding the suitability of the products for any particular purpose or the continuing production of any product. To the maximum extent permitted by applicable law, Vishay disclaims (i) any and all liability arising out of the application or use of any product, (ii) any and all liability, including without limitation special, consequential or incidental damages, and (iii) any and all implied warranties, including warranties of fitness for particular purpose, non-infringement and merchantability.

Statements regarding the suitability of products for certain types of applications are based on Vishay's knowledge of typical requirements that are often placed on Vishay products in generic applications. Such statements are not binding statements about the suitability of products for a particular application. It is the customer's responsibility to validate that a particular product with the properties described in the product specification is suitable for use in a particular application. Parameters provided in datasheets and / or specifications may vary in different applications and performance may vary over time. All operating parameters, including typical parameters, must be validated for each customer application by the customer's technical experts. Product specifications do not expand or otherwise modify Vishay's terms and conditions of purchase, including but not limited to the warranty expressed therein.

Except as expressly indicated in writing, Vishay products are not designed for use in medical, life-saving, or life-sustaining applications or for any other application in which the failure of the Vishay product could result in personal injury or death. Customers using or selling Vishay products not expressly indicated for use in such applications do so at their own risk. Please contact authorized Vishay personnel to obtain written terms and conditions regarding products designed for such applications.

No license, express or implied, by estoppel or otherwise, to any intellectual property rights is granted by this document or by any conduct of Vishay. Product names and markings noted herein may be trademarks of their respective owners.