

注記
NOTES:

1. 材質
MATERIAL
ハウジング: LCP (液晶ポリマー)、ガラス充填、黒色、UL 94V-0
HOUSING: LCP (LIQUID CRYSTAL POLYMER), GLASS FILLED, BLACK, UL 94V-0
ターミナル: 銅合金 (t=0.15)
TERMINAL: COPPER ALLOY (t=0.15)
ネイル: 銅合金 (t=0.2)
NAIL: COPPER ALLOY (t=0.2)
2. メッキ仕様
PLATING
ターミナル
TERMINAL
接点部: 金メッキ 0.25マイクロメートル以上
CONTACT AREA: GOLD 0.25 MICROMETER MINIMUM
半田付け部: 金メッキ 0.4マイクロメートル以下
SOLDER TAIL AREA: GOLD 0.4 MICROMETER MAXIMUM
下地メッキ: ニッケルメッキ 1.5マイクロメートル以上
UNDER PLATING: NICKEL 1.5 MICROMETER MINIMUM
ネイル
NAIL
錫メッキ 3.0マイクロメートル以上
Sn 3.0 MICROMETER MINIMUM
下地メッキ: ニッケルメッキ 1.0マイクロメートル以上
UNDER PLATING: Ni 1.0 MICROMETER MINIMUM
3. テール平坦度は、0.08ミリメートル以下。テールとネイルを併せた平坦度は、0.1ミリメートル以下。
TAIL COPLANARITY TO BE 0.08 MAXIMUM. TAILS AND NAILS COPLANARITY TO BE 0.1 MAXIMUM.
4. 嵌合相手: 55299-**** (H=3mm)
: 55201-****, 55650-**** (H=2mm)
MATED CONN.: 55299-**** (H=3mm)
: 55201-****, 55650-**** (H=2mm)
5. この製品は54363-***01, (エンボス梱包品 54363-***08) の鉛フリー品です。
THIS PRODUCT IS 'LEAD FREE' OF 54363-***01, (EMBOSSED TAPE PKG 54363-***08)

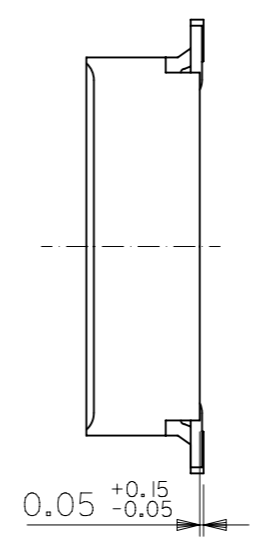

40.5	41.9	39.5	43.9	54363-1678	54363-1671	160	—
35.5	36.9	34.5	38.9	54363-1478	54363-1471	140	○
30.5	31.9	29.5	33.9	54363-1278	54363-1271	120	○
28	29.4	27	31.4	54363-1178	54363-1171	110	○
25.5	26.9	24.5	28.9	54363-1078	54363-1071	100	○
23	24.4	22	26.4	54363-0978	54363-0971	90	—
20.5	21.9	19.5	23.9	54363-0878	54363-0871	80	○
18	19.4	17	21.4	54363-0778	54363-0771	70	○
15.5	16.9	14.5	18.9	54363-0678	54363-0671	60	○
13	14.4	12	16.4	54363-0578	54363-0571	50	○
10.5	11.9	9.5	13.9	54363-0478	54363-0471	40	○
5.5	6.9	4.5	8.9	54363-0278	54363-0271	20	○
D	C	B	A	エンボス梱包品 EMBOSSED TAPE PACKAGING	製品番号 MATERIAL NO.	極数 CIRCUITS	量産対応 AVAILABLE

GENERAL TOLERANCES (UNLESS SPECIFIED)		DIMENSION UNITS		SCALE		CURRENT REV DESC: OBSOLETE PART NUMBER					
0.25 UNDER UNDER ±0.03		mm		10:1		NUMBER					
0.25 OVER 0.5 UNDER ±0.05		GENERAL TOLERANCES (UNLESS SPECIFIED)		MM INCH		EC NO: 618242		PRODUCT CUSTOMER DRAWING			
0.5 OVER 1.0 UNDER ±0.1		4 PLACES ± ±		± ±		DRWN: AKUMAR19 2019/03/12		DOCUMENT NUMBER			
1.0 OVER 10 UNDER ±0.2		3 PLACES ± ±		± ±		CHK'D: GGA 2020/02/28		DOC TYPE DOC PART REVISION			
10 OVER 30 UNDER ±0.25		2 PLACES ± ±		± ±		APPR: GGA 2020/02/28		SD-54363-038 PSD 001 C			
30 OVER ±0.3		1 PLACE ± ±		± ±		INITIAL REVISION:		MATERIAL NUMBER CUSTOMER SHEET NUMBER			
		0 PLACES ± ±		± ±		DRWN: A.IDA 2004/01/06		SEE TABLE GENERAL MARKET 1 OF 2			
		ANGULAR TOL ± 3.0°		± 3.0°		APPR: H.TAKASE 2004/01/06					
		DRAFT WHERE APPLICABLE MUST REMAIN WITHIN DIMENSIONS		THIRD ANGLE PROJECTION		DRAWING SERIES					
				A3-SIZE		54363					

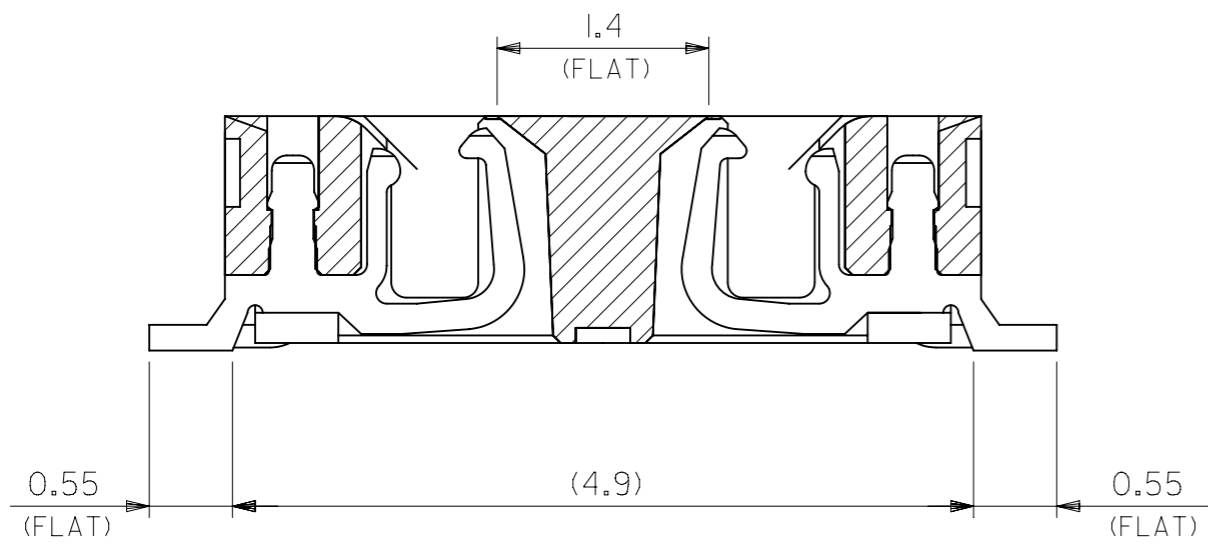

製品断面図 (半田付け部、吸着面寸法)
 DETAIL FOR SOLDERING AND VACUUM AREA

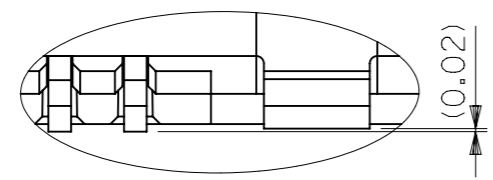

T部詳細
 DETAIL T

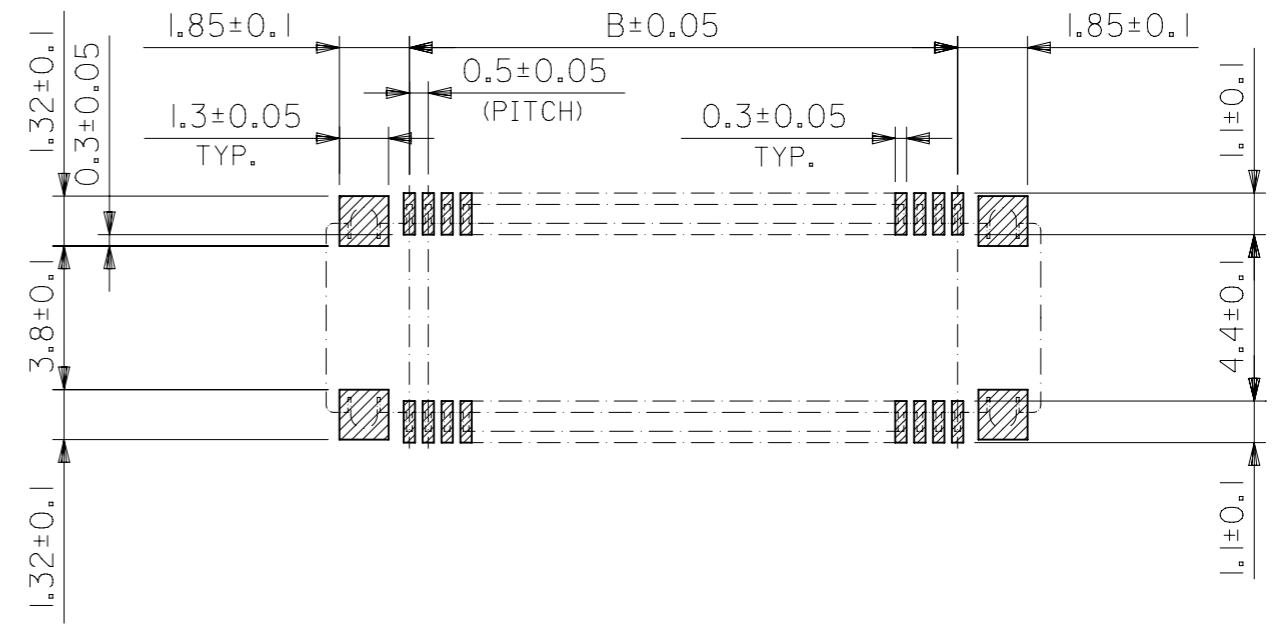

推奨基板寸法
 RECOMMENDED PCB PATTERN LAYOUT
 (SCALE:5-1)

GENERAL TOLERANCES (UNLESS SPECIFIED) 0.25 UNDER UNDER ±0.03 0.25 OVER 0.5 UNDER ±0.05 0.5 OVER 1.0 UNDER ±0.1 1.0 OVER 10 UNDER ±0.2 10 OVER 30 UNDER ±0.25 30 OVER ±0.3			DIMENSION UNITS: mm INCH SCALE: 20:1 GENERAL TOLERANCES (UNLESS SPECIFIED) 4 PLACES ± ± 3 PLACES ± ± 2 PLACES ± ± 1 PLACE ± ± 0 PLACES ± ± ANGULAR TOL ± 3.0° DRAFT WHERE APPLICABLE MUST REMAIN WITHIN DIMENSIONS		THIS DRAWING CONTAINS INFORMATION THAT IS PROPRIETARY TO MOLEX ELECTRONIC TECHNOLOGIES, LLC AND SHOULD NOT BE USED WITHOUT WRITTEN PERMISSION CURRENT REV DESC: OBSOLETE PART NUMBER EC NO: 618242 DRWN: AKUMAR19 2019/03/12 CHK'D: GGA 2020/02/28 APPR: GGA 2020/02/28 INITIAL REVISION: DRWN: A.IDA 2004/01/06 APPR: H.TAKASE 2004/01/06			molex 0.5 PITCH B/B CONN. REC. HOUSING ASSY (H=2,3) WITH NAIL -LEAD FREE- PRODUCT CUSTOMER DRAWING							
DOCUMENT STATUS P1 RELEASE DATE 2020/02/28 02:32:57			THIRD ANGLE PROJECTION		DRAWING A3-SIZE			SERIES 54363		MATERIAL NUMBER SEE TABLE		CUSTOMER GENERAL MARKET		SHEET NUMBER 2 OF 2	

注)
NOTES

1. 製品番号54363-**71 詳細寸法については、製品単体図面を参照下さい。
IN THE PACKAGE PART NUMBER 54363-**71 DETAILED DIMENSIONS, SEE SALES DRAWING FOR CONNECTOR.
2. 梱包数量：2500個/リール
NUMBER OF CONNECTORS:2500 PCS/REEL.
3. リードテープ長さ
LEAD TAPE LENGTH

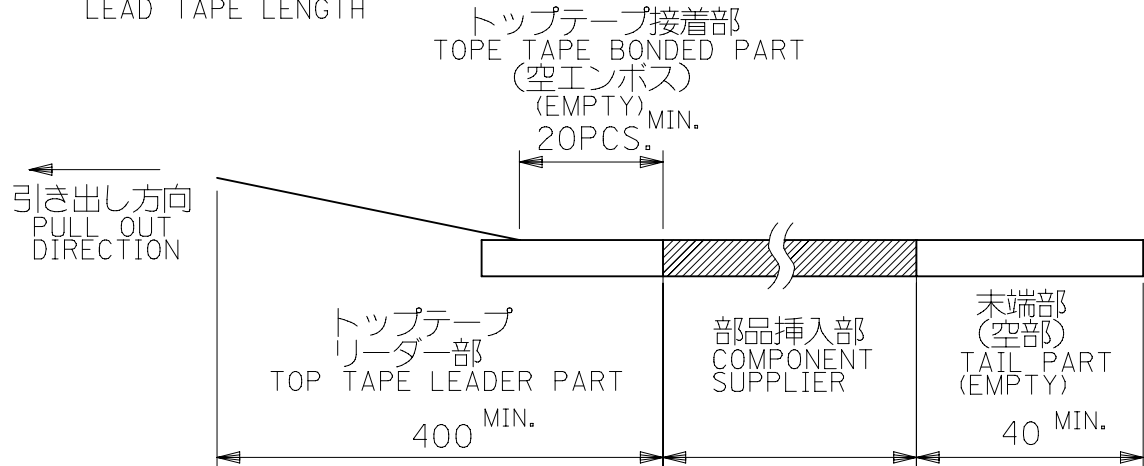
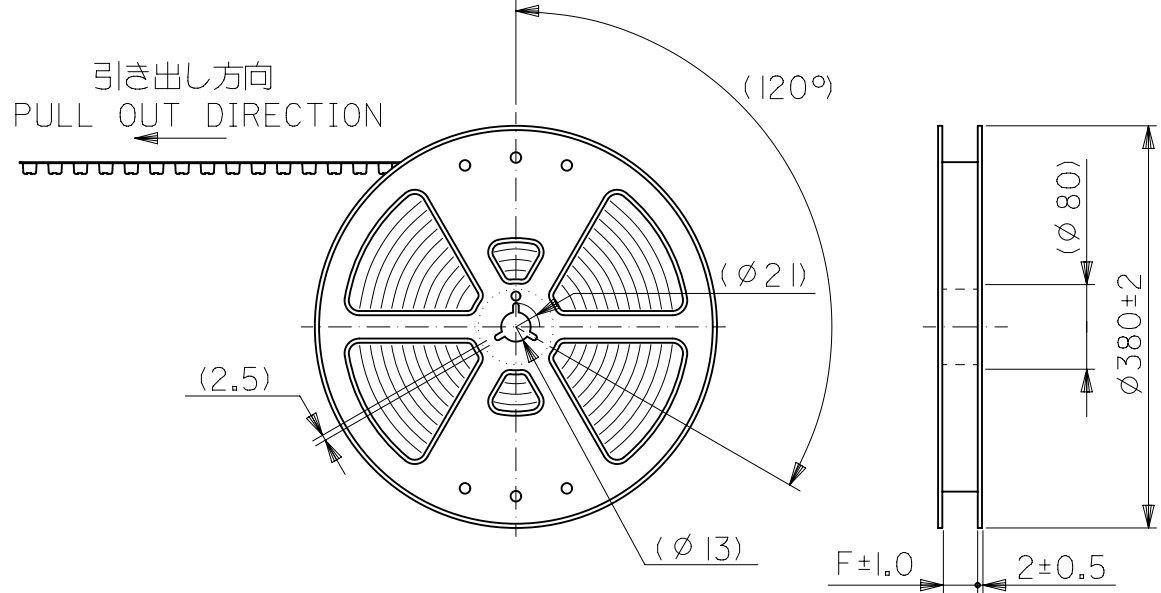

4. トップテープの剥離強度：(剥離方向は下図参照)
PEELING OFF FORCE OF TOP TAPE (PELLING DIRECTION AS SHOWN IN FOLLOWING FIGURE.)
0. 1~1. 3N (10~130gf)

尚、本規格値は、出荷時に適用。
THIS REQUIREMENT SHOULD BE APPLIED AT SHIPMENT.
(但し、輸送時に剥離が発生しない事。)
(PEEL OFF SHOULD NOT BE ALLOWED, DURING TRANSPORTATION.)

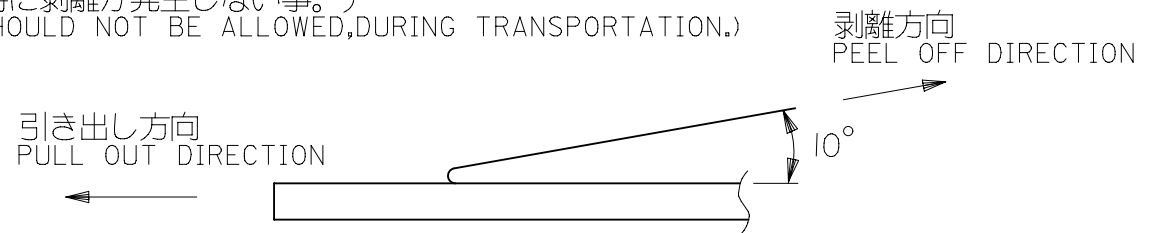

5. 材料
MATERIAL
キャリアテープ：ポリプロピレン (PP)
CARRIER TAPE: POLYPROPYLENE (PP)
トップテープ：PET, PE, PEF
TOP TAPE: PET, PE, PEF
リール：ポリスチレン
REEL: POLYSTYRENE

6. この製品は54363-**01, (エンボス梱包品 54363-**08) の鉛フリー品です。
THIS PRODUCT IS 'LEAD FREE' OF 54363-**01, (EMBOSSED TAPE PKG 54363-**08)

MATERIAL 材料	注記参照 SEE NOTES	GENERAL TOLERANCES: (UNLESS SPECIFIED) 一般公差		THIS DRAWING CONTAINS INFORMATION THAT IS PROPRIETARY TO MOLEX ELECTRONIC TECHNOLOGIES, LLC AND SHOULD NOT BE USED WITHOUT WRITTEN PERMISSION								
		10 UNDER 未満	±0.2	DIMENSION UNITS	SCALE	CURRENT REV DESC: OBSOLETE PART NUMBER						EMBOSSED TAPE PACKAGE FOR 54363-**71 -LEAD FREE-
		10 OVER 以上	30 UNDER 未満	±0.25	mm	NTS	EC NO: 618242		DRWN: AKUMAR19 2019/03/12			
		30 OVER 以上	±0.3	GENERAL TOLERANCES (UNLESS SPECIFIED)		3 PLACES ±		CHK'D: GGA 2020/02/28		APPR: GGA 2020/02/28		
FINISH 仕上げ	注記参照 SEE NOTES	ANGLE 角度		4 PLACES ±		INITIAL REVISION:		DOCUMENT NUMBER		DOC TYPE	DOC PART	REVISION
WIRE RANGE 適用電線範囲		— # —	±3°	3 PLACES ±		DRWN: AIDA 2004/02/10		SD-54363-039		PSD	001	B
INS. RANGE 被覆外径		— # —		2 PLACES ±		APPR: JMIYAZAWA 2004/02/10		PRODUCT CUSTOMER DRAWING		SHEET NUMBER		
DRAFT WHERE APPLICABLE MUST REMAIN WITHIN DIMENSIONS		THIRD ANGLE PROJECTION		DRAWING		SERIES		MATERIAL NUMBER		CUSTOMER		SHEET NUMBER
DOCUMENT STATUS	P1	RELEASE DATE	2020/02/28 02:32:58	B-SIZE		54363		SEE TABLE		GENERAL MARKET		1 OF 2

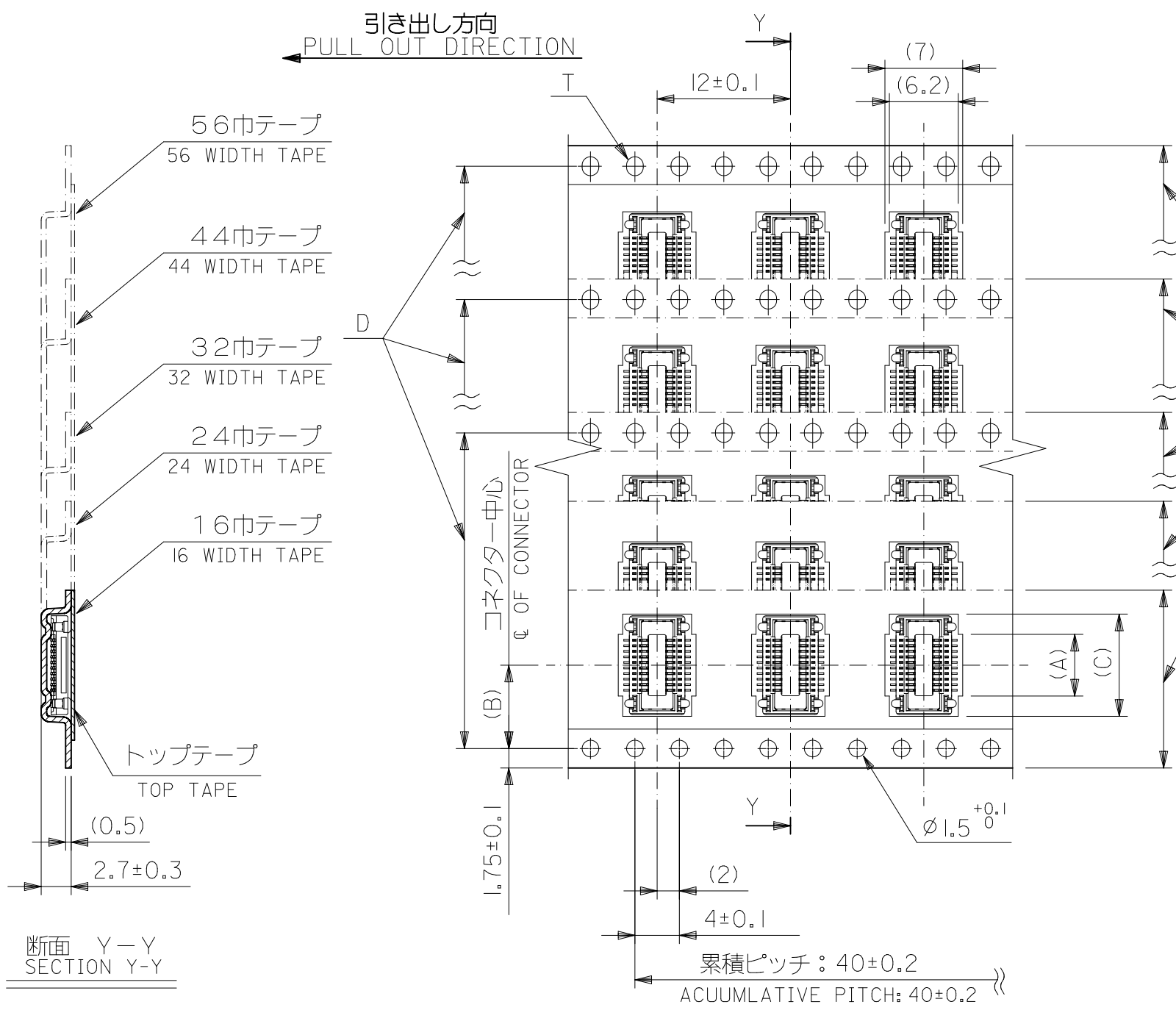

57.5	56±0.3	52.4	44.2	26.2	40.55	54363-1678	160	—
			39.2		35.55	54363-1478	140	○
			34.2		30.55	54363-1278	120	○
45.5	44±0.3	40.4	31.7	20.2	28.05	54363-1178	110	○
			29.2		25.55	54363-1078	100	○
			26.7		23.05	54363-0978	90	—
			24.2		20.55	54363-0878	80	○
33.5	32±0.3	28.4	21.7	14.2	18.05	54363-0778	70	○
			19.2		15.55	54363-0678	60	○
25.5	24±0.3	#	16.7		13.05	54363-0578	50	○
			14.2	11.5	10.55	54363-0478	40	○
17.5	16±0.3	#	9.2	7.5	5.55	54363-0278	20	○
F	E キャリアテープ幅 CARRIER TAPE WIDTH	D	(C)	(B)	(A)	製品番号 MATERIAL NO.	極数 CIRCUITS	量産対応 AVAILABLE

MATERIAL 材料	— # —	GENERAL TOLERANCES: (UNLESS SPECIFIED) 一般公差	10 UNDER 未満	±0.2
FINISH 仕上げ	— # —	10 OVER 30 UNDER 以上 未満	±0.25	
WIRE RANGE 適用電線範囲	— # —	30 OVER 以上	±0.3	
INS. RANGE 被覆外径	— # —	ANGLE 角度	±3°	

THIS DRAWING CONTAINS INFORMATION THAT IS PROPRIETARY TO MOLEX ELECTRONIC TECHNOLOGIES, LLC AND SHOULD NOT BE USED WITHOUT WRITTEN PERMISSION

DIMENSION UNITS	SCALE	CURRENT REV DESC: OBSOLETE PART NUMBER
mm	NTS	
GENERAL TOLERANCES (UNLESS SPECIFIED)		
4 PLACES ±	MM	INCH
3 PLACES ±		
2 PLACES ±		
1 PLACE ±		
0 PLACES ±		
ANGULAR TOL ± °		

EC NO: 618242
 DRWN: AKUMAR19 2019/03/12
 CHK'D: GGA 2020/02/28
 APPR: GGA 2020/02/28

INITIAL REVISION:
 DRWN: AIDA 2004/02/10
 APPR: JMIYAZAWA 2004/02/10

DRAFT WHERE APPLICABLE MUST REMAIN WITHIN DIMENSIONS

THIRD ANGLE PROJECTION

DRAWING SERIES: B-SIZE 54363

MATERIAL NUMBER: SEE TABLE

CUSTOMER: GENERAL MARKET

SHEET NUMBER: 2 OF 2

molex

EMBOSSSED TAPE PACKAGE FOR 54363-**71 -LEAD FREE-

PRODUCT CUSTOMER DRAWING

DOCUMENT NUMBER: SD-54363-039

DOC TYPE: PSD

DOC PART: 001

REVISION: B