

ITEM	PART NO.	DESCRIPTION	Q'TY	REV	DATE	DESCRIPTION	APPROVAL	REF.
1	KM40	40MM WIRE FORM FAN GUARD		0	08-27-04	ORIGINAL RELEASE	<i>JF</i>	
2								
3								
4								
5								

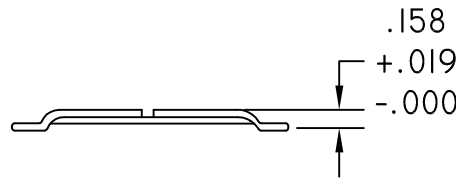
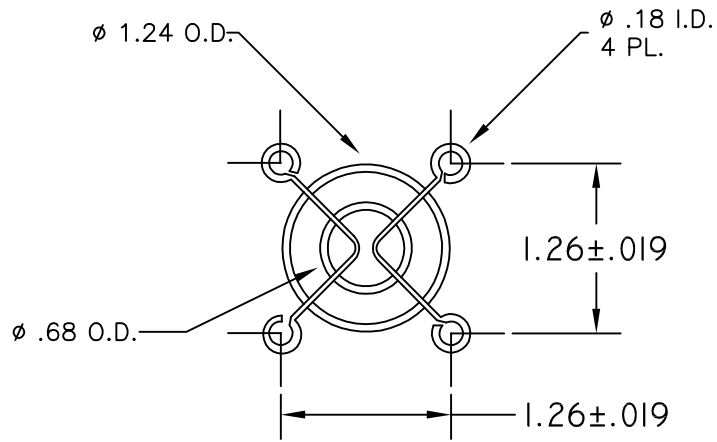

KM40

MAT'L:

WIRE, STEEL C1008 ELECTROPLATED BRIGHT NICKEL CHROME, CLEAR ZINC, ELECTRO DEPOSIT. PLATING THICKNESS = .0005" min.

WELD JOINTS TO WITHSTAND MIN. 70LBS. SEPARATION FORCE TO MEET UL/CSA STANDARDS. CONFORMS TO U.L. $\phi 1/4$ " PLUG GAGE TEST

<small>UNLESS NOTED: TOLERANCES SHALL BE X = $\pm .300$.XX = $\pm .150$.XXX = $\pm .075$ ANGULAR = $\pm 2'$</small>	REMARKS			SHOWN Q'TY	OPPOSITE Q'TY
	THIRD ANGLE	SCALE	MATERIAL	APPROVED BY: <i>JF</i>	DRAWN BY: <i>BEA</i>
	METRIC			DATE: 08-27-04	DATE: 08-27-04
<small>THIS DRAWING IS THE PROPERTY OF SANYO DENKI AMERICA, INC. AND SHALL BE DEEMED AS PROPRIETARY INFORMATION. USE OF ANY INFORMATION CONTAINED HEREIN SHALL BE PROHIBITED WITHOUT WRITTEN PERMISSION OF SANYO AMERICA, INC.</small>	MODEL			NAME	
	SANYO DENKI AMERICA, INC. TORRANCE, CALIFORNIA, U.S.A.			DRAWING NO.	REVISED
			KM40	0	