



HCPL0452, HCPL0453, HCPL0500, HCPL0501, HCPL0530, HCPL0531, HCPL0534 High Speed Transistor Optocouplers

Single Channel: HCPL0452 HCPL0453 HCPL0500 HCPL0501
Dual Channel: HCPL0530 HCPL0531 HCPL0534

Features

- High speed – 1 MBit/s
- 15kV/μs minimum common mode transient immunity at $V_{CM} = 1500V$ (HCPL0453/0534)
- Open collector output
- Guaranteed performance over temperature: 0°C to 70°C
- U.L. recognized (File # E90700)
- VDE0884 recognized (file#136616)
 - approval pending for HCPL0530/0531/0453
 - ordering option V, e.g., HCPL0500V
- BSI recognized (file# 8661, 8662)
 - HCPL0452/0500/0501 only

Applications

- Line receivers
- Pulse transformer replacement
- Output interface to CMOS-LSTTL-TTL
- Wide bandwidth analog coupling

Description

The HCPL05XX, and HCPL04XX optocouplers consist of an AlGaAs LED optically coupled to a high speed photodetector transistor housed in a compact 8-pin small outline package.

A separate connection for the bias of the photodiode improves the speed by several orders of magnitude over conventional phototransistor optocouplers by reducing the base-collector capacitance of the input transistor. The HCPL04XX devices do not have the base bonded out to a lead for additional noise margin. The HCPL053X devices have two channels per package for optimum mounting density.

Truth Table (positive Logic)

LED	V _o
ON	LOW
OFF	HIGH

Package Dimensions

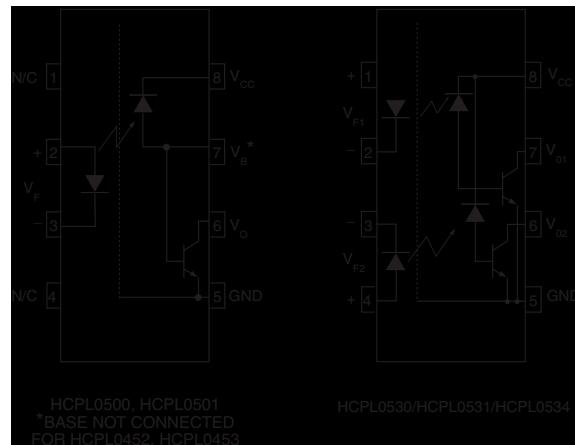
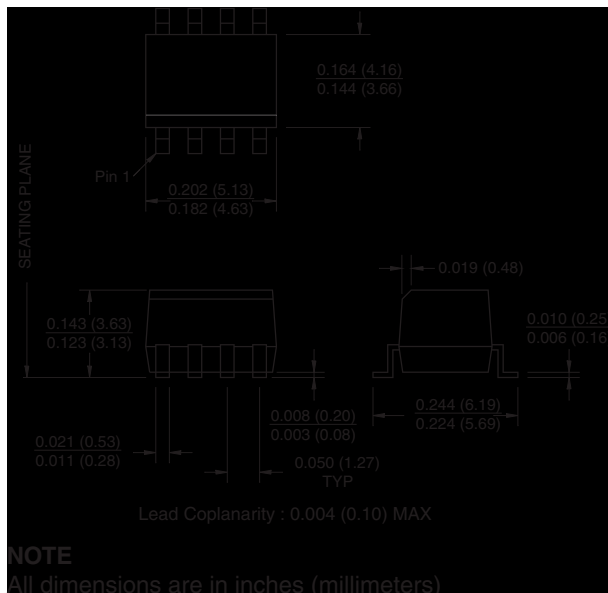

Absolute Maximum Ratings ($T_A = 25^\circ\text{C}$ unless otherwise specified)

Symbol	Parameter	Value	Units
T_{STG}	Storage Temperature	-40 to +125	$^\circ\text{C}$
T_{OPR}	Operating Temperature	-40 to +85	$^\circ\text{C}$
	Reflow Temperature Profile (Refer to page 9)		
EMITTER			
I_F (avg)	DC/Average Forward Input Current	25	mA
I_F (pk)	Peak Forward Input Current (50% duty cycle, 1 ms P.W.)	50	mA
I_F (trans)	Peak Transient Input Current - ($\leq 1 \mu\text{s}$ P.W., 300 pps)	1.0	A
V_R	Reverse Input Voltage	5	V
P_D	Input Power Dissipation	45	mW
DETECTOR			
I_O (avg)	Average Output Current (Pin 6)	8	mA
I_O (pk)	Peak Output Current	16	mA
V_{EBR}	Emitter-Base Reverse Voltage (HCPL0500/HCPL0501 only)	5	V
V_{CC}	Supply Voltage	-0.5 to 30	V
V_O	Output Voltage	-0.5 to 20	V
I_B	Base Current (HCPL0500/HCPL0501 only)	5	mA
P_D	Output power dissipation	100	mW

Electrical Characteristics ($T_A = 0$ to 70°C Unless otherwise specified)

Individual Component Characteristics

Symbol	Parameter	Test Conditions	Device	Min	Typ**	Max	Unit
V_F	EMITTER	$(I_F = 16 \text{ mA}, T_A = 25^\circ\text{C})$	All		1.45	1.7	V
	Input Forward Voltage	$(I_F = 16 \text{ mA})$					
BV_R	Input Reverse Breakdown Voltage	$(I_R = 10 \mu\text{A})$	All	5.0			V
$(\Delta V_F / \Delta T_A)$	Temperature coefficient of forward voltage	$(I_F = 16 \text{ mA})$	All		-1.6		mV/ $^\circ\text{C}$
I_{OH}	DETECTOR	$(I_F = 0 \text{ mA}, V_O = V_{CC} = 5.5\text{V}, T_A = 25^\circ\text{C})$	All		0.001	0.5	μA
	Logic high output current	$(I_F = 0 \text{ mA}, V_O = V_{CC} = 15 \text{ V}, T_A = 25^\circ\text{C})$	All		0.005	1	
		$(I_F = 0 \text{ mA}, V_O = V_{CC} = 15 \text{ V})$	All			50	
I_{CCL}	Logic low supply current	$(I_F = 16 \text{ mA}, V_O = \text{Open}, V_{CC} = 15 \text{ V})$	HCPL0452/3/0500/1		120	200	μA
			HCPL0530/1/4			400	
I_{CCH}	Logic high supply current	$(I_F = 0 \text{ mA}, V_O = \text{Open}, V_{CC} = 15 \text{ V}, T_A = 25^\circ\text{C})$	All		0.01	1	μA
			HCPL0452/3/0500/1			2	
			HCPL0530/1/4			4	

Transfer Characteristics ($T_A = 0$ to 70°C Unless)

Symbol	Parameter	Test Conditions	Device	Min	Typ**	Max	Unit
CTR	COUPLED	$(I_F = 16 \text{ mA}, V_O = 0.4 \text{ V})$ $(V_{CC} = 4.5 \text{ V}, T_A = 25^\circ\text{C})$	HCPL0500/0530	7	2.7	50	%
			HCPL0452/3	19	27	50	
			HCPL0501/0531				
	Current transfer ratio (Note 1)	$(I_F = 16 \text{ mA}, V_O = 0.5 \text{ V})$ $(V_{CC} = 4.5 \text{ V})$	HCPL0500	5	30		
			HCPL0452/3	15	30		
V_{OL}	Logic low output voltage	$(I_F = 16 \text{ mA}, I_O = 1.1 \text{ mA})$ $(V_{CC} = 4.5 \text{ V}, T_A = 25^\circ\text{C})$	HCPL0500		0.18	0.4	V
			HCPL0530			0.5	
		$(I_F = 16 \text{ mA}, I_O = 3 \text{ mA})$ $(V_{CC} = 4.5 \text{ V}, T_A = 25^\circ\text{C})$	HCPL0452/3		0.25	0.4	
			HCPL0501/0531/4				
		$(I_F = 16 \text{ mA}, I_O = 0.8 \text{ mA})$ $(V_{CC} = 4.5)$	HCPL0500		0.13	0.5	
			HCPL0530				
		$(I_F = 16 \text{ mA}, I_O = 2.4 \text{ mA})$ $(V_{CC} = 4.5)$	HCPL0452/3		0.23	0.5	
HCPL0501/0531/4							

** All typicals at $T_A = 25^\circ\text{C}$

Switching Characteristics ($T_A = 0$ to 70°C unless otherwise specified., $V_{CC} = 5 \text{ V}$)

Symbol	Parameter	Test Conditions	Device	Min	Typ**	Max	Unit
T_{PHL}	Propagation delay time to logic low	$T_A = 25^\circ\text{C}, (R_L = 4.1 \text{ k}\Omega, I_F = 16 \text{ mA})$ (Note 2) (Fig. 9)	HCPL0500/0530		0.45	1.5	μs
			HCPL0452/3		0.45	0.8	
		HCPL0501/0531/4					
		$(R_L = 1.9 \text{ k}\Omega, I_F = 16 \text{ mA})$ (Note 3) (Fig. 9) $T_A = 25^\circ\text{C}$	HCPL0500/0530			2.0	
			HCPL0452/3			1.0	
T_{PLH}	Propagation delay time to logic high	$T_A = 25^\circ\text{C}, (R_L = 4.1 \text{ k}\Omega, I_F = 16 \text{ mA})$ (Note 2) (Fig. 9)	HCPL0500/0530		0.5	1.5	μs
			HCPL0452/3		0.3	0.8	
		HCPL0501/0531/4					
		$(R_L = 1.9 \text{ k}\Omega, I_F = 16 \text{ mA})$ (Note 3) (Fig. 9) $T_A = 25^\circ\text{C}$	HCPL0500/0530			2.0	
			HCPL0452/3			1.0	
ICM_H	Common mode transient immunity at logic high	$(I_F = 0 \text{ mA}, V_{CM} = 10 \text{ V}_{P-P}, R_L = 4.1 \text{ k}\Omega)$ (Note 4) (Fig. 10) $T_A = 25^\circ\text{C}$	HCPL0500	1,000	10,000		V/ μs
			HCPL0530				
		$(I_F = 0 \text{ mA}, V_{CM} = 10 \text{ V}_{P-P})$ $T_A = 25^\circ\text{C}, (R_L = 1.9 \text{ k}\Omega)$ (Note 4) (Fig. 10)	HCPL0452	1,000	10,000		
			HCPL0501/31				
		$(I_F = 16 \text{ mA}, V_{CM} = 1500 \text{ V}_{P-P}, R_L = 1.9 \text{ k}\Omega,$ $T_A = 25^\circ\text{C})$ (Note 4) (Fig. 10)	HCPL0534	15,000	40,000		
ICM_L	Common mode transient immunity at logic low	$(I_F = 16 \text{ mA}, V_{CM} = 10 \text{ V}_{P-P}, R_L = 4.1 \text{ k}\Omega)$ (Note 4) (Fig. 10) $T_A = 25^\circ\text{C}$	HCPL0500	1,000	10,000		V/ μs
			HCPL0530				
		$(I_F = 16 \text{ mA}, V_{CM} = 10 \text{ V}_{P-P})$ $T_A = 25^\circ\text{C}, (R_L = 1.9 \text{ k}\Omega)$ (Note 4) (Fig. 10)	HCPL0452	1,000	10,000		
			HCPL0501/31				
		$(I_F = 16 \text{ mA}, T_A = 25^\circ\text{C}, V_{CM} = 1500 \text{ V}_{P-P},$ $C_L = 15 \text{ pF})$ (Note 4) (Fig. 10)	HCPL0534	15,000	40,000		
	HCPL0453	15,000	40,000				

Isolation Characteristics ($T_A = 0^\circ\text{C}$ to $+70^\circ\text{C}$ Unless otherwise specified.)

Symbol	Characteristics	Test Conditions	Min	Typ**	Max	Unit
V_{ISO}	Input-Output Isolation Voltage	(note 5, 6) ($f = 60 \text{ Hz}$, $t = 1.0 \text{ min}$) ($I_{I-O} \leq 2 \mu\text{A}$)	2500	—	—	$V_{ac_{RMS}}$
R_{ISO}	Isolation Resistance	(note 5) ($V_{I-O} = 500 \text{ V}$) ⁽⁹⁾	10^{11}	—	—	—
C_{ISO}	Isolation Capacitance	(note 5) ($V_{I-O} = 0$, $f = 1.0 \text{ MHz}$) ⁽⁹⁾	—	0.2	—	pF

** All typicals at $T_A = 25^\circ\text{C}$

NOTES

1. Current Transfer Ratio is designed as a ratio of output collector current, I_O , to the forward LED input current, I_F times 100%.
2. The 4.1 k Ω load represents 1 LSTTL unit load of 0.36 mA and 6.1k Ω pull-up resistor.
3. The 1.9 k Ω load represents 1 TTL unit load of 1.6 mA and 5.6 k Ω pull-up resistor.
4. Common mode transient immunity in logic high level is the maximum tolerable (positive) dV_{cm}/dt on the leading edge of the common mode pulse signal V_{CM} , to assure that the output will remain in a logic high state (i.e., $V_O > 2.0 \text{ V}$). Common mode transient immunity in logic low level is the maximum tolerable (negative) dV_{cm}/dt on the trailing edge of the common mode pulse signal, V_{CM} , to assure that the output will remain in a logic low state (i.e., $V_O < 0.8 \text{ V}$).
5. Device is considered a two terminal device: Pins 1, 2, 3 and 4 are shorted together and Pins 5, 6, 7 and 8 are shorted together.
6. 2500 VAC RMS for 1 minute duration is equivalent to 3000 VAC RMS for 1 second duration.

Typical Performance Curves

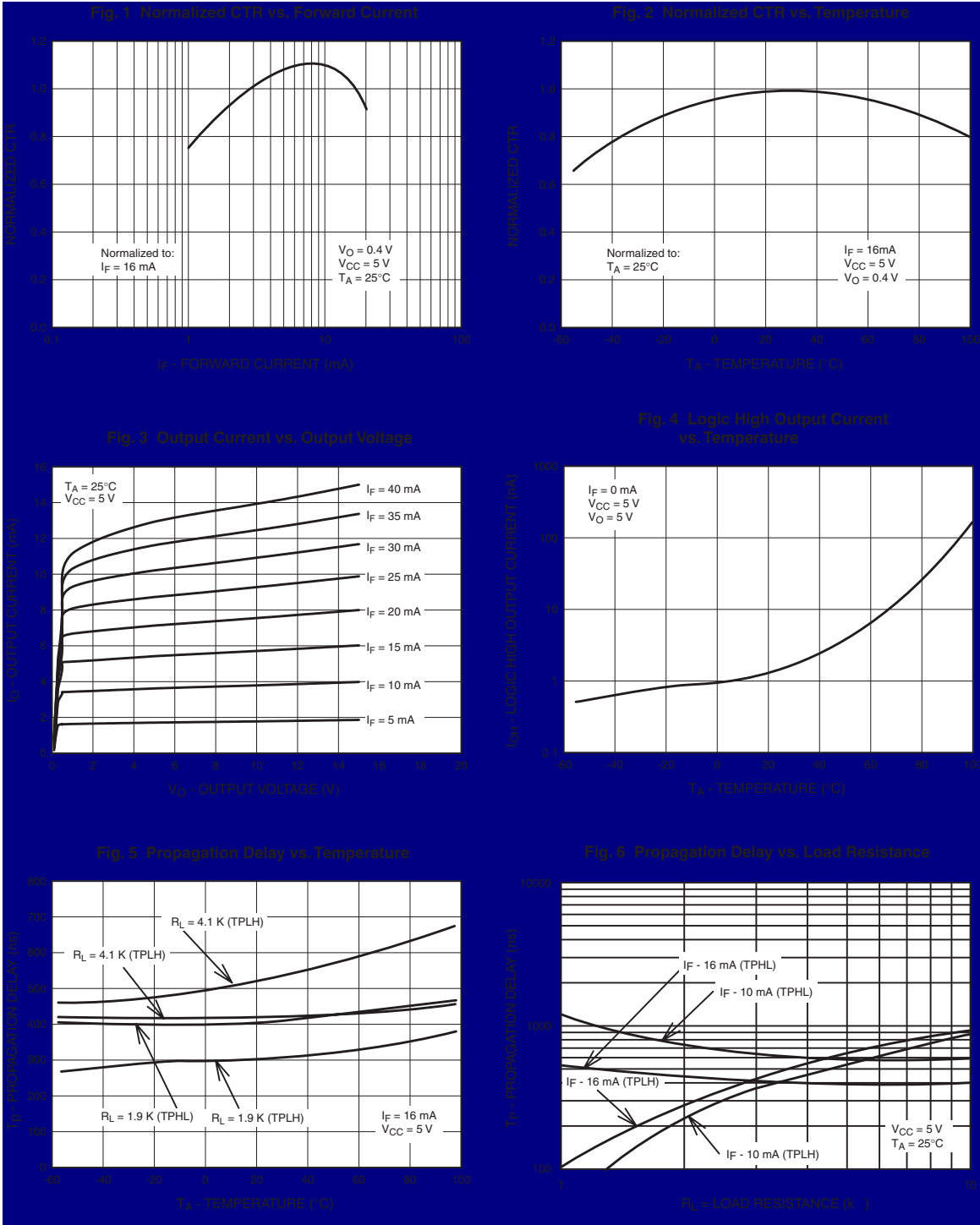

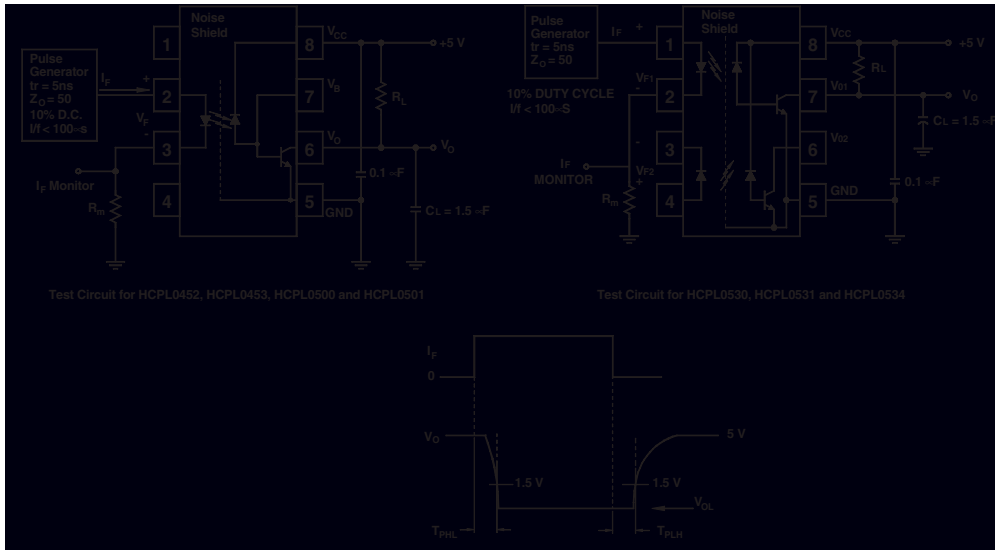

Fig. 7 Switching Time Test Circuit

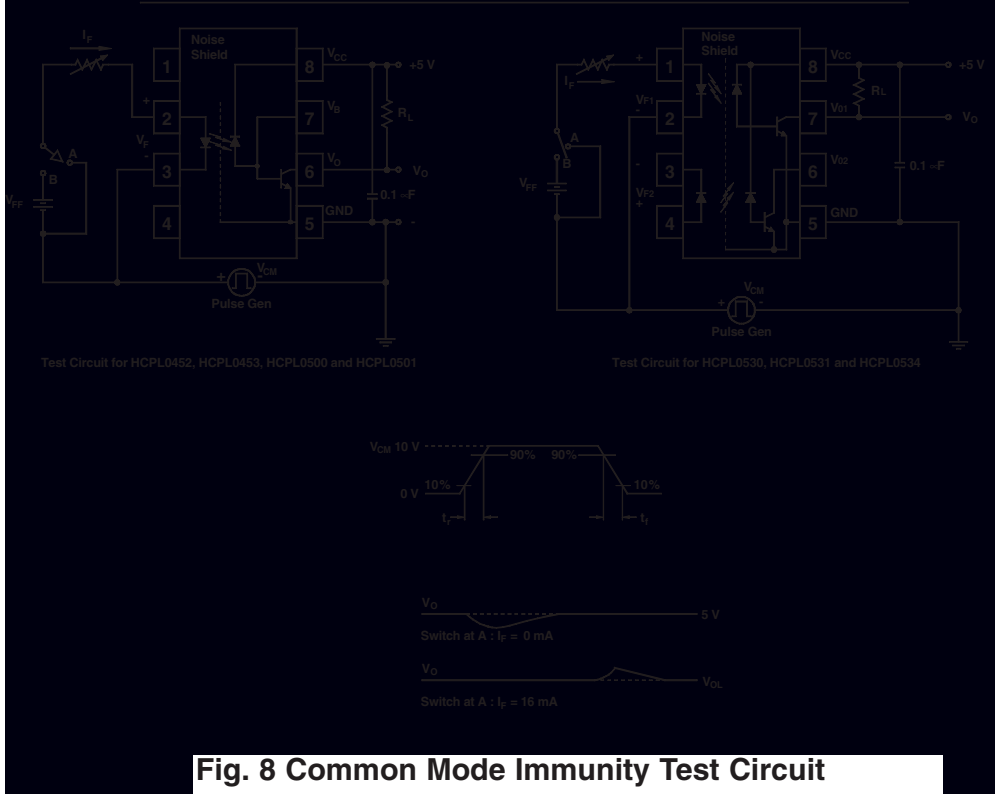
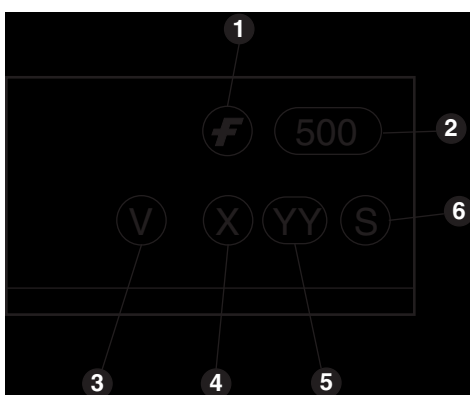

Fig. 8 Common Mode Immunity Test Circuit

Ordering Information

Option	Order Entry Identifier	Description
V	V	VDE 0884 (approval pending for HCPL0530, HCPL0531 & HCPL0534)
R1	R1	Tape and reel (500 units per reel)
R1V	R1V	VDE 0884 (approval pending for HCPL0530, HCPL0531 & HCPL0534), Tape and reel (500 units per reel)
R2	R2	Tape and reel (2500 units per reel)
R2V	R2V	VDE 0884 (approval pending for HCPL0530, HCPL0531 & HCPL0534), Tape and reel (2500 units per reel)

Marking Information



Definitions	
1	Fairchild logo
2	Device number
3	VDE mark (Note: Only appears on parts ordered with VDE option – See order entry table)
4	One digit year code, e.g., '3'
5	Two digit work week ranging from '01' to '53'
6	Assembly package code

Carrier Tape Specifications

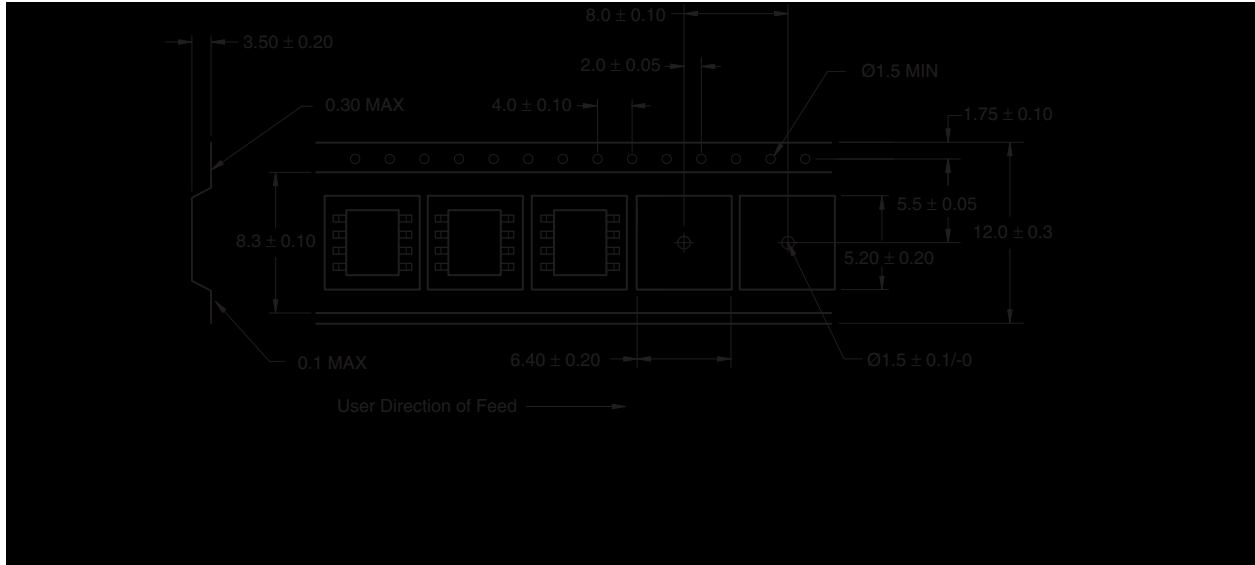

Reflow Profile

